

TOOLS & EQUIPMENT



Cordless Power Tools.....	758-782
Corded Power Tools.....	783-800
Air Tools.....	801-828
Compressors	829-835
Abrasives	836-881
Cutting Tools	882-909
Chemicals	910-930
Brushes	931
Fume Extractors.....	932-933
Welding Protection.....	934-935
Welding & Metalworking.....	936-985
Tool Sets	986-989
Socket Sets	990-995
Sockets.....	996-1007
Torque Wrenches	1008-1009
Wrenches.....	1010-1016
Screwdrivers & Nutdrivers	1017-1021
Insert Bits & Hex Keys	1021
Bits.....	1022-1024
Hex Keys.....	1025-1026
Pliers.....	1026-1034
Insulated Tools	1035
Clamps	1036-1041
Vises	1042-1045
Non-Sparking, Non-Magnetic Tools.....	1046-1047
Bolt Cutters.....	1048
Scissors & Snips	1049-1051
Files.....	1051-1054
Hammers.....	1055-1060
Hacksaws	1060
Pry Bars & Punches.....	1060-1064
Caulking Guns.....	1064
Magnets	1065-1067
Measures, Rules, Squares & Levels	1068-1075
Plumbing Tools.....	1076-1080
Tool Storage.....	1081-1098
Fuel Transfer Tanks.....	1099



CORDLESS POWER TOOLS

4 V M4™ 1/4" HEX SCREWDRIVERS

- 21-position clutch setting with auto shut-off
- Includes: (2x) M4™ 2.0 battery and M4™ charger

SPECIFICATIONS

Voltage:	4 V
Chuck Size:	1/4" Hex
Maximum Torque:	44 in.-lbs.
# of Speed Settings:	2
# of Speed Settings:	2
No Load RPM Setting #1:	0-200
No Load RPM Setting #2:	0-600
Clutch Settings:	21
Tool Weight:	0.85 lbs.
Replacement Battery Model No.:	TLV691

Model No. TLV684
Mfg. No. 2101-22
Price/Each \$209.00



Milwaukee

12 V LITHIUM-ION SUB-COMPACT CORDLESS DRILL/DRIVER KITS

- Clutch settings: 14+1
- Features: Light compact design
- Built-in LED light
- Battery Fuel gauge
- Includes: (2x) 1.4 Ah Lithium-Ion Batteries, Charger and Tool bag
- Battery Type: Lithium-Ion

SPECIFICATIONS

Voltage:	12 V
Chuck Size:	1/4"
Max Torque:	150 in.-lbs.
# of Speed Settings:	1
No Load RPM Setting #1:	0-500
Chuck Type:	Hex quick change
Tool Weight:	2.1 lbs.
Replacement Battery Model No.:	TLZ368

Model No.	Mfg. No.	Desc.	Price/Each
TMB540	2401-20	Tool Only	85.00
TLZ166	2401-22	Tool & Kit	151.00



1/4" CORDLESS DRIVER/DRILL

- Auto stop system indicates battery power reduction and stops operation when battery reaches minimal capacity in order to prevent incomplete fastening
- Locking feature prevents accidental start up and enables use as a hand-held screwdriver
- Adjustable handle with enhanced hinge mechanism for operational versatility
- LED job light illuminates work area and features independent on/off switch
- Includes: Two 7.2 V Li-Ion (1.5 ah) batteries, charger, Phillips bit 1-50, Phillips bit 2-50, battery plastic case, plastic carrying case

SPECIFICATIONS

Voltage:	7.2 V
Chuck Size:	1/4"
Battery Type:	Lithium-Ion
Max Torque:	71 in.-lbs.
# of Speed Settings:	2
No Load RPM Setting #1:	0-200
No Load RPM Setting #2:	0-650
Tool Weight:	0.9 lbs.

Model No. TYW999
Mfg. No. DF012DSE
Price/Each \$229.00



Makita

XTREME™ BRUSHLESS SCREWDRIVER KIT

- Designed for hard to reach fastening applications that require clutch control
- Brushless motor for Maximum runtime and durability
- Quick release drop and load hex that accepts 1" bit tips
- 3 LED lights on nose for work surface illumination
- Includes: (1) 12 V Max* brushless 1/4" screwdriver, (2) 12 V Max* 2 Ah batteries with state of charge indicator, (1) 12 V and 20 V Max* charger, (1) Belt clip, (1) Kit bag

SPECIFICATIONS

Voltage:	12 V
Chuck Size:	1/4"
Max Torque:	200 UWO
No Load RPM Setting:	0-1100
Tool Weight:	1.5 lbs.

Model No.	Mfg. No.	Desc.	Price/Each
UAF547	DCF601B	Tool Only	139.00
UAF542	DCF601F2	Tool & Kit	199.00



DEWALT

18 V M18™ 1/2" COMPACT DRILL/DRIVERS

- Compact, ergonomic drill/driver with an all-metal gear case for maximum durability
- Most compact drill/driver in its class
- Includes: (2) M18™ Redlithium™ compact battery, multi-voltage 12 V-18 V charger and carrying case

SPECIFICATIONS

Voltage:	18 V
Chuck Size:	1/2"
Max Torque:	500 in.-lbs.
# of Speed Settings:	2
No Load RPM Setting #1:	0-450
No Load RPM Setting #2:	0-1800
Max BPM:	0-29 000
Clutch Settings:	Adjustable
Chuck Type:	1/2" metal
Tool Weight:	3.6 lbs.

Model No.	Mfg. No.	Desc.	Price/Each
TYD849	2606-20	Tool Only	173.00
TLV700	2606-22	Tool & Kit	250.00



Milwaukee

12 V M12™ FUEL™ 1/4" HEX 2-SPEED SCREWDRIVERS

- Redlithium™ Battery Technology delivers more work per charge and more work over pack life than any battery on the market
- Redlink Plus™ Intelligence provides optimized performance and overload protection using total system communication between tool, battery and charger
- LED light
- Includes: (2x) M12™ Redlithium™ 2.0 compact battery pack, M12™ Lithium-Ion battery charger, belt clip and hard carrying case

SPECIFICATIONS

Voltage:	12 V
Chuck Size:	1/4"
Max Torque:	325 in.-lbs.
# of Speed Settings:	2
No Load RPM Setting #1:	0-450
No Load RPM Setting #2:	0-1700
Chuck Type:	Hex quick change
Tool Weight:	2.0 lbs.
Replacement Battery Model No.:	TLV694

Model No.	Mfg. No.	Desc.	Price/Each
TMB553	2402-20	Tool Only	150.00
TLV679	2402-22	Tool & Kit	215.00



Milwaukee

XTREME™ BRUSHLESS DRILL DRIVER KIT

- Ideal for precision applications like drilling small pilot holes
- Can accept up to a 1/2" spade bit
- Brushless motor for efficient performance and runtime
- Features a bright LED positioned light on the foot to illuminate work areas
- Includes: (1) 12 V Max* brushless 3/8" drill driver, (2) 12 V Max* 2 Ah batteries with state of charge indicator, (1) 12 V and 20 V Max* charger, (1) Belt clip, (1) Tool bag

SPECIFICATIONS

Voltage:	12 V
Chuck Size:	3/8"
Max Torque:	250 UWO
Speed Settings:	2
No Load RPM Setting:	0-1500
Clutch Settings:	15
Tool Weight:	1.9 lbs.



DEWALT

Model No.	Mfg. No.	Desc.	Price/Each
UAF546	DCD701B	Tool Only	165.00
UAF540	DCD701F2	Tool & Kit	235.00

1/2" CORDLESS HAMMER DRILL/DRIVER

- Battery protection system provides over-discharge, temperature and circuit protection for enhanced performance, battery cycle life and overall battery life
- Twin LED jobs light with pre-glow and after-glow functions
- Improved ergonomic soft rubber grip design for vibration absorption and comfortable operation features re-contoured rear grip portion and ribbed grip for improved hold
- Includes: Hook, Double ended bit 2-45, 1/2" Keyless drill chuck
- Battery Type: Lithium-Ion

SPECIFICATIONS

Voltage:	18 V
Chuck Size:	1/2"
Clutch Settings:	21
Chuck Type:	Keyless drill chuck
Max Torque:	480 in.-lbs.
# of Speed Settings:	2
No Load RPM Settings #1:	0-600
No Load RPM Settings #2:	0-1900
BPM Settings #1:	0-9000
BPM Settings #2:	0-28 500
Tool Weight:	3.5 lbs.



Makita

Model No.	Mfg. No.	Desc.	Price/Each
UAF053	DHP482Z	Tool Only	179.00

M18™ 1/2 IN. BRUSHLESS HAMMER DRILL DRIVER KIT

- Small, light build allows for excellent control, especially while working in overhead or tight spaces
- All-metal gear case
- Includes: (1) M18 1/2" Brushless Hammer Drill (Tool Only) (2902-20), (2) M18™ Redlithium™ XC 4.0 Extended Capacity Battery Pack (48-11-1840), (1) M18™ & M12™ Multi-Voltage Charger (48-59-1812), (1) Carrying Case, (1) Side Handle, (1) Belt Clip

SPECIFICATIONS

Voltage:	18 V
Chuck Size:	1/2"
Torque:	725 in.-lbs
RPM:	0-550/0-1800

Model No.	Mfg. No.	Desc.	Price/Each
UAE112	2902-20	Tool Only	238.00
UAE113	2902-22	Tool & Kit	427.00



Milwaukee

M12 FUEL™ DRILL/DRIVER KIT

- Powerstate™ Brushless Motor delivers the most power
 - Only 5.9" in length for the most access in tight spaces
 - Fastest drilling and driving applications under load
 - Powerstate™ Brushless Motor delivers the power to complete the widest range of applications of any subcompact drill driver
 - Light Weight at 2.5 lbs for tool belt portability and less fatigue in the work day
 - 1/2" all-metal chuck for maximum durability, grip and bit retention
 - Mechanical clutch for consistency in driving a wide range of fasteners
 - Unmatched Performance with the most runtime in class with the M12 Redlithium™ XC4.0 battery pack
 - All-metal gear case for ultimate durability
 - All-metal belt clip for portability
 - LED light for better visibility in low-light situations
- Refinable Attributes**
- Battery Type: Lithium-Ion

SPECIFICATIONS

Voltage:	12 V
Chuck Size:	1/2"
Max Torque:	400 in.-lbs.

Model No.	Mfg. No.	Desc.	Price/Each
UAV642	3403-20	Tool Only	181.00
UAV643	3403-22	Tool & Kit	238.00



Milwaukee

12 V M12™ 3/8" HAMMER DRILL/DRIVERS

- On-board battery Fuel gauge displays remaining run time
- New ergonomic handle design for increased comfort
- LED light
- Includes: (2x) M12™ Redlithium™ battery, M12™ Lithium-Ion battery charger, belt clip and carrying case

SPECIFICATIONS

Voltage:	12 V
Chuck Size:	3/8"
Max Torque:	275 in.-lbs.
# of Speed Settings:	2
No Load RPM Setting #1:	0-400
No Load RPM Setting #2:	0-1500
Chuck Type:	Metal ratcheting
Tool Weight:	2.7 lbs.
Replacement Battery Model No.:	TLZ368

Model No. TLV677
Mfg. No. 2408-22
Price/Each \$217.00



Milwaukee

M12 FUEL™ HAMMER DRILL/DRIVER KIT

- Powerstate™ Brushless Motor delivers the most power
- Only 6.0" in length for the most access in tight spaces
- Fastest drilling and driving applications under load
- Powerstate™ Brushless Motor delivers the power to complete the widest range of applications of any subcompact hammer drill driver
- Light Weight at 2.6 lbs for tool belt portability and less fatigue in the work day
- 1/2" All-metal chuck for maximum durability, grip and bit retention
- Mechanical clutch for consistency in driving a wide range of fasteners
- Unmatched Performance with the most runtime in class with the M12 Redlithium™ XC4.0 battery pack
- All-metal gear case for ultimate durability
- All-metal belt clip for portability
- LED light for better visibility in low-light situations
- Battery Type: Lithium-Ion

SPECIFICATIONS

Voltage:	12 V
Chuck Size:	1/2"

Model No.	Mfg. No.	Desc.	Price/Each
UAV644	3404-20	Tool Only	211.00
UAV645	3404-22	Tool & Kit	271.00



Milwaukee

CORDLESS POWER TOOLS

M18 FUEL™ DRILL/DRIVER KIT

- Most powerful compact drill driver in its class
- 6.9" in length for access into tight spaces and reduced fatigue
- Fastest drilling and driving applications under load
- Only 6.9" in length for access into tight spaces and reduced fatigue
- Auto-Stop™ Control Mode for enhanced safety
- Powerstate™ Brushless Motor delivers the power to complete the widest range of applications of any drill driver
- Auto-Stop feature to protect from over-rotation in a bind-up for enhanced safety, equipped with a dedicated autostop light on foot of tool to indicate a protection event
- 1/2" All-metal chuck with carbide teeth for maximum durability, grip and bit retention
- Mechanical clutch for consistency in driving a wide range of fasteners
- Unmatched Performance with the most runtime in class with the XC5.0Ah batteries
- All-metal gear case for ultimate durability
- All-metal belt clip for portability
- Battery Type: Lithium-Ion

SPECIFICATIONS

Voltage: 18 V
Chuck Size: 1/2"
Max Torque: 1400 in.-lbs.

Model No.	Mfg. No.	Desc.	Price/Each
UAV638	2903-20	Tool Only	271.00
UAV639	2903-22	Tool & Kit	458.00



M18 FUEL™ HAMMER DRILL/DRIVER WITH ONE-KEY™

- For fast drilling into brick, block, or concrete
- Only 6.9" in length for access into tight spaces and reduced fatigue
- Autostop™ Control mode protects from over rotation in a bind up for enhanced safety, equipped with a dedicated Autostop™ light on foot of tool to indicate a protection event
- Powerstate™ Brushless Motor delivers the power to complete the widest range of applications of any hammer drill driver
- 1/2" all-metal chuck with carbide teeth for maximum durability, grip, and bit retention
- Mechanical Clutch for consistency in driving a wide range of fasteners
- All-metal belt clip for portability
- LED light for better visibility in low-light situations
- Voltage: 18 V
- Chuck Size: 1/2"
- Battery Type: Lithium-Ion
- Includes: (1) M18 Fuel™ 1/2" Hammer Drill/Driver (2906-20), (1) Side Handle, (1) Belt Clip
- Length: 6.9"

SPECIFICATIONS

Voltage: 18 V
Chuck Size: 1/2"
Torque: 1400 in.-lbs

Model No.	Mfg. No.	Desc.	Price/Each
AUW322	2906-20	Tool Only	358.00



M18 FUEL™ HAMMER DRILL/DRIVER KIT

- Most powerful compact hammer drill in its class
- 6.9" in length for access into tight spaces and reduced fatigue
- Fastest drilling and driving applications under load
- Only 6.9" in length for access into tight spaces and reduced fatigue
- Auto-Stop™ Control Mode for enhanced safety
- Powerstate™ Brushless Motor delivers the power to complete the widest range of applications of any hammer drill driver
- Auto-Stop feature to protect from over-rotation in a bind-up for enhanced safety, equipped with a dedicated autostop light on foot of tool to indicate a protection event
- 1/2" All-metal chuck with carbide teeth for maximum durability, grip and bit retention
- Mechanical clutch for consistency in driving a wide range of fasteners
- Unmatched Performance with the most runtime in class with the XC5.0Ah batteries
- Hammer Drill Mode for fast drilling into brick, block or concrete
- All-metal belt clip for portability
- Battery Type: Lithium-Ion

SPECIFICATIONS

Voltage: 18 V
Chuck Size: 1/2"

Model No.	Mfg. No.	Desc.	Price/Each
UAV640	2904-20	Tool Only	305.00
UAV641	2904-22	Tool & Kit	468.00



MAX XR® BRUSHLESS D-HANDLE ROTARY HAMMER KIT

- Optimized mechanism provides faster application speed
- DeWalt™ electronics allow the tool to maintain speed through the entire application without bogging down, even with the largest bits
- Durable German-engineered mechanism for long service life, even in the hardest concrete
- Compact size allows access to space restricted areas
- Includes: Adjustable side handle with integrated depth stop rod, Soft-sided case, 4.0 Ah battery packs, Charger

SPECIFICATIONS

Voltage: 20 V
Chuck Type: SDS+
Battery Type: Lithium-Ion
No Load RPM: 0-1500



Model No.	Mfg. No.	Desc.	Price/Each
UAE538	DCH133B	Tool Only	345.00
UAI767	DCH133M2	Tool & Kit	549.00



DRILL & IMPACT DRIVER BIT HOLDER

- Retains bits better than magnet bit holders
- Keeps bits out of the way
- Holds 1/4" hex shank bits
- Retains bits better than magnets
- Includes: Bit holder, Short M18 Screw, M12 Adapter, and Long M12 Screw
- Used on either side of the tool
- Durable material survives drops
- Non-Marring Rubber
- Holds up to 4 bits at a time
- Compatible with M18 Fuel™, M18™ and M12 Fuel™ sold today
- No. of Pockets: 4

Model No. UAV649
Mfg. No. 49-16-3697
Price/Each \$20.00



M18 FUEL™ 1-9/16" SDS MAX HAMMER DRILL KIT

- Brushless motor runs cooler, lasts longer and delivers up to 55% faster application speed
- Rotary hammer is able to drill as fast as a corded drill
- Delivers impact energy for the more demanding, heavy-duty applications
- Type: Lithium-Ion
- Battery Warranty: 3 years
- Tool Warranty: 5 years
- Includes: (1) M18 Fuel™ 1-9/16" SDS max hammer drill, (1) M18™ & M12™ rapid charger, (2) M18™ Redlithium™ High Demand™ 9.0 battery pack, (1) side handle, (1) carrying case



SPECIFICATIONS

Voltage:	18 V
Chuck Size:	1 9/16"
# of Speed Settings:	1
No Load RPM:	0-450
Handle Style:	D-handle
Tool Weight:	12.15 lbs.

Model No.	Mfg. No.	Desc.	Price/Each
TYX826	2715-20	Tool Only	823.00
TYX077	2715-22	Tool & Kit	1298.00

20 V XR LI-ION BRUSHLESS 3-SPEED HAMMER DRILL KIT

- 3-Speed, all-metal high performance transmission optimizes tool-to-task for fast application speeds and improved run-time
- XR Li-Ion batteries with fuel gauge provide 33% more capacity over standard packs
- 3-Mode LED provides lighting in dark or confined spaces up to 20x brighter than previous model
- Heavy-duty 1/2" ratcheting nitro-carburized metal chuck with carbide inserts for superior bit gripping strength
- Includes: (2) 20 V MAX XR high capacity Li-Ion batteries, charger, belt hook, 360° side handle, kit box



SPECIFICATIONS

Voltage:	20 V
Chuck Size:	1/2"
Max Torque:	820 UWO
Battery Type:	Lithium-Ion
# of Speed Settings:	3
No Load RPM:	0-2250
BPM:	0-38250
Clutch Settings:	11
Chuck Type:	Metal, ratcheting
Tool Weight:	4.9 lbs.

Model No.	Mfg. No.	Desc.	Price/Each
UAG130	DCD996B	Tool Only	315.00
TYW992	DCD996P2	Tool & Kit	585.00

MAX XR® BRUSHLESS L-SHAPE ROTARY HAMMER KIT

- Brushless motor for extended runtime and durability
- Shocks™ Active Vibration Control reduces vibration felt by the user at the handles
- Outstanding power-to-weight ratio, results in superior productivity
- Factory-set clutch reduces sudden, high torque reactions if bit jams
- Retractable utility hook for convenient hanging
- Optimized ergonomic design provides exceptional overhead drilling experience
- Compatible with D25303DH Dust Extractor
- Includes: (2) 20 V Max lithium-ion 5.0 Ah batteries, (1) Fast charger, (1) 360° Side handle, (1) Depth rod, (1) Retractable utility hook



SPECIFICATIONS

Voltage:	20 V
Chuck Type:	SDS+
Battery Type:	Lithium-Ion
No Load RPM:	0-1100

Model No.	Mfg. No.	Desc.	Price/Each
UA1768	DCH273B	Tool Only	489.00
TLV945	DCH273P2	Tool & Kit	839.00

M18 FUEL™ SDS PLUS D-HANDLE ROTARY HAMMER

- Delivers faster than corded speed, corded durability and all-day work on one charge
- RedLink™ Plus intelligence integrates full-circle communication between tool, battery and charger to protect from overloading, overheating and over-discharging
- RedLithium™ XC 5.0 Battery Packs (not included) provide all-day work on one charge, 20% more power and 2 times more recharges than standard lithium-ion batteries
- Features 3 drilling modes: rotary hammer, hammer only, and rotation only
- In-line ergonomics provide extended reach for overhead and downward drilling applications
- Compatible with all M18™ batteries and M18™ chargers
- Manufacturer's Warranty: 5-Year Limited Warranty



SPECIFICATIONS

Voltage:	18 V
Bit Capacity:	1" - 2-1/2"
Rotary Hammer Size:	1"
Battery Type:	Lithium-Ion
No Load RPM:	1270
No Load BPM:	4580
Impact Energy:	2.1 ft.-lbs.

Model No.	Mfg. No.	Desc.	Price/Each
UAV797	2613-20	Tool Only	304.00

ATOMIC COMPACT SERIES™ BRUSHLESS CORDLESS HAMMER DRILL KIT

- Shortest hammer drill at 6.49" (tool head length only) to access hard to reach areas
- Get up to 14% more power and up to 1650 RPMs for a variety of drilling applications
- High bit retention with 1/2" ratcheting chuck
- Unlock power in a compact size with 552 UWO† and up to 28,050 BPMs to tackle tough jobs in tight spaces
- Illuminate workspaces using the on-tool LED work light
- Manufacturer's Warranty: 3-Year Limited Warranty
- Includes: (1) Hammer Drill, (1) Impact Driver, (2) Batteries



SPECIFICATIONS

Voltage:	20 V
Chuck Size:	1/2"
Battery Type:	Lithium-Ion

Model No.	Mfg. No.	Desc.	Price/Each
AUW237	DCD799D1	Tool & Kit	285.00

M18 FUEL™ SDS MAX ROTARY HAMMER WITH ONE-KEY™ KIT

- Powerstate® brushless motor delivers constant power under heavy load to maintain drilling speed
- Autostop™ E-Clutch
- Rotary hammer & hammer only modes
- Redlink Plus™ Intelligence provides optimized performance and overload protection using total system communication between tool, battery and charger
- Includes: (1) M18™ Fuel™ 1-3/4" SDS Max Rotary Hammer w/ One-Key™ (Tool Only) (2718-20), (2) M18 Redlithium™ High Output™ HD12.0 Battery Packs (48-11-1812), (1) M18™ & M12™ Rapid Charger (48-59-1808), (1) Carrying Case (1) Grease Tube, (1) Side Handle



SPECIFICATIONS

Voltage:	18 V
Amps:	15 A
Bit Capacity:	1-3/4"
Rotary Hammer Size:	1"
Battery Type:	Lithium-Ion
No Load RPM:	380
No Load BPM:	2900
Impact Energy:	8.1 ft.-lbs.
Vibration:	10 m/s ²

Model No.	Mfg. No.	Desc.	Price/Each
UAE149	2718-22HD	Tool & Kit	1799.00

CORDLESS POWER TOOLS



M18 FUEL™ SDS PLUS ROTARY HAMMER KIT

- Fastest drilling rotary hammer in its class
- Autostop™ control for enhanced safety
- Can drill up to (125) 3/8" x 2" holes per charge when paired with the M18™ High Output™ XC6.0 Battery
- Powerstate™ brushless motor
- Redlink Plus™ Intelligence tool technology ensures maximum rotary drill performance and protects it from overload, overheating, and over-discharge
- Autostop™ Kickback Control prevents over-rotation if the tool gets bound up while drilling in rebar or hard aggregate
- AVS Anti-Vibration System minimizes vibration for maximum comfort
- The M18™ Redlithium™ High Output™ XC6.0 Battery delivers 50% more power while running 50% cooler than the M18™ Redlithium™ XC batteries
- Three modes include rotary hammer only, hammer only, and rotary only
- Includes: M18 Fuel™ 1" SDS plus rotary hammer, (2) M18 Redlithium™ High Output™ XC6.0 Battery pack, (1) M18™ & M12™ Rapid charger



SPECIFICATIONS

Voltage:	18 V
Chuck Size:	1"
Battery Type:	Lithium-Ion
No Load RPM:	1330
No Load BPM:	4800
Max. Torque:	2 ft.-lbs.

Model No. UAL111
Mfg. No. 2912-22
Price/Each \$926.00



M18™ FORCE LOGIC™ KNOCKOUT TOOL KIT

- Punches up to 4" holes in 12 gauge mild steel, and 14 gauge stainless steel
- Quick connect alignment system speeds up alignment by delivering the easiest set-up, and enabling the clearest view of the work surface
- Exact punches and dies are rated for both mild and stainless steel punching
- Large size ID markings permit easy punch and die selection
- Compatible with all M18™ batteries
- Exact dies feature vivid red crosshairs for clearest alignment
- Includes: (1) M18™ Redlithium™ CP2.0 battery, (1) M18™ & M12™ Multi-voltage charger, (1) Exact™ Rapid reset 3/4" draw stud set, (1) 7/16" Draw stud, (1) 3/4" Draw stud, (1) Quick connect alignment system, (1) Exact™ 1/2" - 2" Conduit punches and dies, (1) Carrying case

SPECIFICATIONS

Voltage:	18 V
Battery Type:	M18™ Redlithium™ CP2.0 battery
Punch Capacity:	Up to 4"
Output Force:	6 tons

Model No. UAF501
Mfg. No. 2677-21
Price/Each \$1897.00



M12 FUEL™ 16 GAUGE VARIABLE SPEED NIBBLER

- Fast, clean cuts in 16 GA mild steel up to 7' per minute
- Power to cut 22 GA spiral duct seams, 18 GA stainless, and 12 GA aluminum
- Variable speeds provides maximum control for any job
- Ergonomically designed to be light weight, balanced, and comfortable for continuous use
- Tool free 360° die holder rotation
- Equipped with LED work light, and M12 Redlithium™ battery technology
- Manufacturer's Warranty: 5-year Limited Warranty
- Motor Type: Powerstate™ Brushless
- Includes: (1) M12 Fuel™ 16 Gauge Variable Speed Nibbler, (1) Chip Collection Bag



SPECIFICATIONS

Voltage:	12 V
Chuck Size:	1"
Battery Type:	Lithium-Ion
Strokes per Minute (SPM):	2200

Model No.	Mfg. No.	Desc.	Price/Each
UAV749	2476-20	Tool Only	346.00



M18 FUEL™ MAGNETIC DRILL KIT

- Powerstate™ brushless motor delivers maximum power and long motor life
- Redlink Plus™ Intelligence provides optimized performance and overload protection using total system communication between tool, battery and charger
- Self-powered magnet base operates independently of power source and delivers up to 2000 lbs. of holding force
- Auto-stop lift-off detection automatically cuts power to the motor if excess rotational motion is detected while drilling
- Compatible Batteries: M18™
- Chuck Type: Keyless
- Includes: (1) M18 Fuel™ 1-1/2" Magnetic Drill, (2) M18™ Redlithium™ High Output™ XC8.0 Batteries, (1) M18™ & M12™ Rapid Charger, (1) 3/4" Weldon to 1/2" Chuck Adapter, (1) Chuck Key, (1) Magnetic Lubrication Tank, (1) Safety Strap, (1) 1" Retractable Pilot Pin, (1) Carrying Case



SPECIFICATIONS

Voltage:	18 V
Amps:	1 A
Battery Type:	M18™ Redlithium™ High Output™ XC8.0 Battery
Annular Cutter Capacity:	1-1/2"
Twist Bit Capacity:	1/2"
Stroke Length:	5-3/4"
No Load RPM:	690

Model No. UAF962
Mfg. No. 2787-22HD
Price/Each \$3735.00



M12 FUEL™ RIGHT ANGLE IMPACT WRENCH KIT

- Low profile head design allows users for more access in tight spaces
- Long body profile allows for more access
- 4-mode drive control
- Features auto shut-off mode when fastening to prevent over-tightening
- Bolt removal mode for more control after bolt breakaway
- Features LED light
- Includes: Battery, Battery charger, Contractor bag



SPECIFICATIONS

Voltage:	12 V
Socket Size:	3/8"
Battery Type:	Lithium-Ion
No Load RPM:	0-3000
Max. Torque:	220 ft.-lbs

Model No. UAJ277
Mfg. No. 2564-22
Price/Each \$435.00



M12 FUEL™ RIGHT ANGLE IMPACT WRENCH WITH PIN DETENT KIT

- Low profile head design allows users for more access in tight spaces
- Long body profile allows for more access
- 4-mode drive control
- Features auto shut-off mode when fastening to prevent over-tightening
- Bolt removal mode for more control after bolt breakaway
- Features LED light
- Includes: Battery, Battery charger, Contractor bag



SPECIFICATIONS

Voltage:	12 V
Socket Size:	1/2"
Battery Type:	Lithium-Ion
No Load RPM:	0-3000
Max. Torque:	220 ft.-lbs

Model No. UAJ279
Mfg. No. 2565-22
Price/Each \$435.00



1/2" CORDLESS HIGH TORQUE IMPACT WRENCH

- 3 stage impact power selection prevents over-tightening of fasteners
- Variable speed trigger allows operator to adjust fastening speed based on materials or application
- Electric brake prevents over-tightening of fasteners
- Rubber joint construction suppresses transmission of vibration to battery, minimizing battery failures due to terminal breakage or poor electrical contact
- Twin LED job lights with pre-glow and afterglow features illuminates work area
- Nut-busting Torque (Reverse): 1180 ft.-lbs.
- Includes: Two 18 V (5.0 ah) Li-Ion batteries, rapid charger, battery cover, hook, plastic carrying case

SPECIFICATIONS

Voltage:	18 V
Socket Size:	1/2"
Battery Type:	Lithium-Ion
Max Torque:	740 ft.-lbs.
# of Speed Settings:	3
No Load RPM Settings #1:	0-900
No Load RPM Settings #2:	0-1000
No Load RPM Settings #3:	0-1800
Tool Weight:	7.9 lbs.



Makita

Model No.	Mfg. No.	Desc.	Price/Each
UAF044	DTW1002Z	Tool Only	435.00
TYW998	DTW1002RTE	Tool & Kit	759.00

M18 FUEL™ HIGH TORQUE IMPACT WRENCH WITH ONE-KEY™ & FRICTION RING KIT

- Features a friction ring with thru-hole design to ensure quick and easy socket changes
- LED light to illuminate the work area
- Powerstate™ brushless motor delivers up to 1200ft.-lbs of fastening torque and 1500ft.-lbs of nut-busting torque
- Easily toggle up to four custom performance profiles that can be saved to the memory of the tool
- Premium rubber overmold withstands corrosive materials and provides increased comfort when in use
- Warranty: 5-Year Limited

SPECIFICATIONS

Voltage:	18 V
Socket Size:	3/4"
Battery Type:	Lithium-Ion
Max Torque:	1200 ft.-lbs
No Load RPM:	1800
IPM:	2400

Model No. UAV738
Mfg. No. 2864-22R
Price/Each \$785.00



Milwaukee

MAX XR® HIGH TORQUE IMPACT WRENCH KIT

- Multi-speed control for a variety of applications
- LED with 20 second delay for increased visibility
- Includes: (1) 20 V Max XR® 3/4" brushless high torque impact wrench with hog ring anvil, (2) 5.0 Ah batteries, (1) Multi-voltage charger

SPECIFICATIONS

Voltage:	20 V
Socket Size:	3/4"
Max Torque:	700 ft.-lbs
No Load RPM:	0-1900

Model No.	Mfg. No.	Desc.	Price/Each
UA1747	DCF897B	Tool Only	479.00
UA1748	DCF897P2	Tool & Kit	775.00



DEWALT

XR® HIGH TORQUE IMPACT WRENCH WITH HOG RING ANVIL

- Increases user control in a variety of applications with 4-mode speed settings & variable speed trigger
- Designed to help prevent overtightening & fastener run-off with Precision Wrench™ control
- Ideal for large sized pipe flanges, grooved couplings, wheel lugs, concrete anchor bolt setting & many other heavy-duty impact wrench applications
- LED work light illuminates dark workspaces
- Batteryguard™ helps reduce wear & tear on the battery while you work using
- Includes: (1) DCF900 Impact Wrench
- Manufacturer's Warranty: 3 Years Limited, 1 Year Free Service, 90 Days Satisfaction Guaranteed

SPECIFICATIONS

Voltage:	20 V
Socket Size:	1/2"
Battery Type:	Lithium-Ion
Max Fastening Torque:	1030 ft.-lbs
Max Breakaway Torque:	1400 ft.-lbs
No Load RPM:	820
Tool Weight:	6.4 lbs.



DEWALT

Model No.	Mfg. No.	Desc.	Price/Each
UAV746	DCF900B	Tool Only	445.00
UAV747	DCF900P1	Tool & Kit with 1 Battery	585.00
UAV748	DCF900P2	Tool & Kit with 2 Batteries	705.00

M12 FUEL™ STUBBY IMPACT WRENCH KIT

- Proprietary 4-Mode Drive Control™ provides unmatched control
- Auto-shut off mode reduces over-fastening and increases productivity
- Powerstate™ Brushless Motor provides more power, more run-time, and longer life
- Redlink Plus™ Intelligence enables advanced communication between your batteries and tools, allowing for unmatched levels of performance, protection, and productivity
- Redlithium™ batteries deliver more work per charge and more work over the life of the battery
- Includes: M12 Fuel™ 3/8" Stubby impact wrench, M12™ Redlithium™ CP2.0 Battery, M12™ Redlithium™ XC 4.0 Extended capacity battery pack, M12™ Lithium-ion battery charger, Belt clip, Carrying case
- Manufacturer's Warranty: 5 Years

SPECIFICATIONS

Voltage:	12 V
Socket Size:	3/8"
Battery Type:	Lithium-Ion
Max Torque:	250 ft.-lbs
No Load RPM:	2700
IPM:	3200
Tool Weight:	2 lbs.

Model No. UAK187
Mfg. No. 2554-22
Price/Each \$384.00



Milwaukee

CORDLESS POWER TOOLS

M18 FUEL™ WITH ONE-KEY™ HIGH-TORQUE IMPACT WRENCH WITH FRICTION RING

- Powerstate™ brushless motor delivers up to 1000ft-lbs of fastening torque
- REDLINK PLUS™ intelligence prevents damage to the tool and battery due to overloading or overheating
- Redlithium™ batteries deliver more work per charge and more work over the life of the battery
- In addition to tool tracking and security, the One-Key™ feature allows users to dial in precision settings, get alerts before equipment needs repair, and view utilization data from a computer, tablet, or smartphone
- Easily toggle up to four custom performance profiles that can be saved to the memory of the tool
- Features a friction ring design to ensure quick and easy socket changes
- Premium rubber overmold withstands corrosive materials and provides increased comfort when in use
- LED light to illuminate the work area

SPECIFICATIONS

Voltage:	18.0 V
Socket Size:	3/4"
Max Torque:	1500 ft-lbs
No Load RPM:	0-1800

Model No.	Mfg. No.	Desc.	Price/Each
TY191	2864-20	Tool Only	526.00



Milwaukee

IQV20 HIGH TORQUE CORDLESS IMPACT WRENCH KIT

- IQv Power Control System includes 4 power modes
- Shadowless LED light ring with task light mode and 4 dimmable settings
- Variable-speed switch with electronic brake provides Maximum control of the tool
- Compatible with IQV20 Series™ Battery System
- Impact and chemical-resistant housing and patented steel reinforced frame
- Robust and durable all-metal drivetrain and hammer mechanism optimized for Maximum power and efficiency
- Includes: (1) High torque cordless impact wrench W7172, (2) Batteries BL2022, (1) Battery charger, (1) Carrying bag

SPECIFICATIONS

Voltage:	20 V
Socket Size:	3/4"
Max Torque:	1000 ft-lbs, 1360 Nm
No Load RPM:	1900

Model No.	Mfg. No.	Desc.	Price/Each
UAG098	W7172	Tool Only	767.00
UAG099	W7172-K22	Tool & Kit	1114.00

IR
Ingersoll Rand.



HIGH-TORQUE IMPACT WRENCH KIT

- Includes: (2) Lithium-ion batteries, (1) High-Torque Impact Wrench, (1) Battery charger, (1) Bag
- Robust and durable all-metal drivetrain and hammer mechanism optimized for Maximum power and efficiency
- Variable-speed switch (half and full power only) with electronic brake provides Maximum control of the tool and increases safety
- 4 dimmable settings on the shadowless 360° LED light ring

SPECIFICATIONS

Voltage:	20 V
Socket Size:	1/2"
Max Torque:	1500 ft-lbs
No Load RPM:	1900

Model No.	Mfg. No.	Desc.	Price/Each
UAG096	W7252	Tool Only	642.00
UAE354	W7252-K22	Tool & Kit	1018.00

IR
Ingersoll Rand.



M18 FUEL™ WITH ONE-KEY™ HIGH TORQUE IMPACT WRENCH KIT

- Redlink Plus™ intelligence prevents damage to the tool and battery due to overloading or overheating
- M18 Fuel™ with One-Key™ technology provides the most repeatable Impact Wrench in the industry
- Features a friction ring design to ensure quick and easy socket changes
- LED light to illuminate the work area
- Powerstate™ brushless motor delivers up to 1000 ft-lbs of fastening torque and 1400 ft-lbs of nut-busting torque
- Redlithium™ batteries deliver more work per charge and more work over the life of the battery
- One-Key™ technology allows users to customize, track, and manage tool's performance and location
- Easily toggle up to four custom performance profiles that can be saved to the memory of the tool
- Premium rubber overmold withstands corrosive materials and provides increased comfort when in use
- Includes: (1) M18 FUEL™ with ONE-KEY™ High Torque Impact Wrench 1/2" Friction Ring (2863-20), (2) M18™ Redlithium™ XC5.0 Resistant Batteries (48-11-1850R), (1) M18™ & M12™ Multi-Voltage Charger (48-59-1812), (1) Blow Molded Case

SPECIFICATIONS

Voltage:	18 V
Socket Size:	1/2"
Battery Type:	Lithium-Ion
Max Torque:	1400 ft-lbs

Model No.	UAV728
Mfg. No.	2863-22R
Price/Each	\$762.00



Milwaukee

M18 FUEL™ ANVIL CONTROLLED TORQUE IMPACT WRENCH WITH ONE-KEY™ KIT

- Controller torque output
- Faster tire service
- PowerState™ Brushless Motor delivers up to 750 ft-lbs of fastening torque and 1,100 ft-lbs of nut-busting torque
- Part of the M18™ System, featuring over 175+ Tools
- RedLink Plus™ Intelligence prevents damage to the tool and battery due to overloading or overheating
- One-Key™ Compatible: Ability to Customize, Track and Manage tools for increased productivity and investment protection
- LED light to illuminate the work area
- 4 customizable Drive Control™ modes provide multiple fastening torque outputs designed for vehicles such as sedans, light trucks and box trucks
- Enables users to perform faster tire service by removing the hassle of pneumatic hoses, compressors, and torque sticks
- RedLithium™ batteries (not included with Bare Tool) deliver more work per charge and more work over the life of the battery
- Premium rubber overmold withstands corrosive materials and provides increased comfort when in use
- Includes: (1) M18 Fuel™ 1/2" Ext. Anvil Controlled Torque Impact Wrench with One-Key™ (2769-20), (2) M18™ RedLithium™ XC5.0 Resistant Battery (48-11-1850R), (1) M18™ & M12™ Multi-Voltage Charger (48-59-1812), (1) Contractor Bag

SPECIFICATIONS

Voltage:	18 V
Socket Size:	1/2"
Battery Type:	Lithium-Ion
No Load RPM:	1800
Max Torque:	1100 ft-lbs

Model No.	UAV811
Mfg. No.	2769-22R
Price/Each	\$817.00



Milwaukee

M18 FUEL™ COMPACT IMPACT WRENCH WITH FRICTION RING KIT

- Friction ring (hog ring) ensures quick and easy socket changes
- The PowerState™ Brushless motor delivers up to 250 ft.-lbs. of nut-busting torque
- 4-Mode Drive Control™ provides greater control over output speed and power. Includes auto shut-off and bolt-removal mode
- Bolt removal control delivers full torque output, then decreases RPMs once the bolt is loosened to prevent fastener drops
- Works in up to to 69 kV environments
- 4.8" in length provides most access in tight spaces
- Tri-LEDs deliver high definition lighting to increase workspace visibility with less shadows
- Auto Shut-Off™ control prevents over tightening and increases productivity by applying no more than 20 ft.-lbs. of torque
- RedLink Plus™ Intelligence ensures maximum performance and protects from overloads, heating and over-discharge
- Includes: (1) M18 Fuel™ 3/8" Compact Impact Wrench with Friction Ring Bare Tool (2854-20), (2) M18™ RedLithium™ XC5.0 Resistant Battery (48-11-1850R), (1) M18™ & M12™ Multi-Voltage Charger (48-59-1812), (1) Carrying Case



SPECIFICATIONS

Voltage:	18 V
Socket Size:	3/8"
Battery Type:	Lithium-Ion
Max Torque:	250 ft.-lbs
No Load RPM:	2400
IPM:	3500

Model No. UAV812
Mfg. No. 2854-22R
Price/Each \$567.00



M18 FUEL™ COMPACT IMPACT WRENCH WITH PIN DETENT KIT



- 4.9" in length provides most access in tight spaces
- Tri-LEDs deliver high definition lighting to increase workspace visibility with less shadows
- Auto shut-off mode prevents over tightening and increases productivity by applying no more than 20 ft.-lbs. of torque
- REDLINK PLUS™ Intelligence ensures maximum performance and protects from overloads, heating and over-discharge
- Compatible with all M18™ batteries & Chargers
- The POWERSTATE™ brushless motor delivers up to 250 ft.-lbs. of nut-busting torque
- 4-Mode DRIVE CONTROL™ provides greater control over output speed and power
- Includes auto shut-off and bolt-removal mode
- Bolt-removal mode offers more control after bolt breakaway as RPMs drastically slow down once the bolt is loosened
- Works in up to to 69 kV environments
- Manufacturer's Warranty: 5 Year (Tool), 3 Years (Battery)
- Motor Type: Brushless

SPECIFICATIONS

Voltage:	18 V
Socket Size:	1/2"
Battery Type:	Lithium-Ion
Max Torque:	250 ft.-lbs
No Load RPM:	2400
IPM:	3500

Model No. UAV813
Mfg. No. 2855P-22R
Price/Each \$567.00



M18 FUEL™ HIGH-TORQUE IMPACT WRENCH WITH PIN DETENT KIT

- Most compact cordless High Torque Impact Wrench in its class at 8.1" in length
- Features a pin detent design for maximum socket retention
- Bolt removal mode provides maximum nut-busting torque to break fastener free, then slows to 750rpm for more control when removing fasteners
- Premium rubber overmold withstands corrosive materials and provides increased comfort when in use
- REDLINK PLUS™ intelligence prevents damage to the tool and battery due to overloading or overheating
- Reduced user fatigue at only 7.1 lbs with battery
- RedLithium™ batteries deliver more work per charge and more work over the life of the battery
- LED light to illuminate the work area
- Manufacturer's Warranty: 5 Year (Tool), 3 Years (Battery)
- Motor Type: Brushless



SPECIFICATIONS

Voltage:	18 V
Socket Size:	1/2"
Battery Type:	Lithium-Ion
Max Torque:	1100 ft.-lbs
No Load RPM:	1800
IPM:	2400

Model No. UAV818
Mfg. No. 2766-22R
Price/Each \$769.00



M18 FUEL™ WITH ONE-KEY™ HIGH TORQUE IMPACT WRENCH PIN DETENT KIT

- Most compact cordless High Torque Impact Wrench in its class at 8.1" in length
- RedLink Plus™ intelligence prevents damage to the tool and battery due to overloading or overheating
- Features a pin detent design for maximum socket retention
- Reduced user fatigue at only 7.1 lbs with battery
- RedLithium™ batteries deliver more work per charge and more work over the life of the battery
- Premium rubber overmold withstands corrosive materials and provides increased comfort when in use
- LED light to illuminate the work area
- One-Key™ Compatible: Customize, Track and Manage tool's performance and location
- PowerState™ brushless motor delivers up to 750ft.-lbs of fastening torque and 1100ft.-lbs of nut-busting torque
- M18 Fuel™ with One-Key™ technology provides the most repeatable Impact Wrench in the industry
- Easily toggle up to four custom performance profiles that can be saved to the memory of the tool
- Includes: (1) M18 Fuel™ with One-Key™ High Torque Impact Wrench 1/2" Pin Detent Kit (2862-22R), (2) M18™ RedLithium™ XC5.0 Resistant Battery (48-11-1850R), (1) M18™ & M12™ Multi-Voltage Charger (48-59-1812), (1) Blow Molded Case



SPECIFICATIONS

Voltage:	18 V
Socket Size:	1/2"
Battery Type:	Lithium-Ion
Max Torque:	1100 ft.-lbs
No Load RPM:	1800

Model No. UAV814
Mfg. No. 2862-22R
Price/Each \$762.00



CORDLESS POWER TOOLS

M18 FUEL™ HIGH TORQUE IMPACT WRENCH WITH ONE-KEY™ KIT

- Eliminates the need for compressors and generators due to the Powerstate™ brushless motor delivering up to 188 ft.-lbs of nut-busting torque
- 4-mode Drive Control™ provides greater control over output speed and power
- Redlink Plus™ intelligence ensures maximum performance and protects from overloads, heating, and over-discharge
- Integrated lanyard loop allows for safer use and easier storage
- In addition to tool tracking and security, the One-Key™ feature allows users to dial in precision settings, get alerts before equipment needs repair, and view utilization data from a computer, tablet, or smartphone
- Handle rotates 270° and easily adjusts without a tool
- Features an LED light to illuminate work area
- Premium rubber overmold withstands corrosive materials and provides increased comfort when in use
- Includes: (1) M18™ Fuel™ High Torque Impact Wrench with One-Key™, (2) M18™ High Output™ XC8.0 batteries, (1) M18™ & M12™ rapid charger, (1) Tool-free adjustable charger, (1) Lanyard loop, (1) Contractor bag



SPECIFICATIONS

Voltage:	18 V
Socket Size:	1"
Battery Type:	Lithium-Ion
Max Torque:	1800 ft.-lbs
Tool Weight:	10.5 lbs.

Model No. UAF076
Mfg. No. 2867-22
Price/Each \$1582.00



M18 FUEL™ D-HANDLE EXTENDED ANVIL HIGH TORQUE IMPACT WRENCH WITH ONE-KEY™ KIT

- Remove lug nuts & bolts on trucks, haulers, and OTR equipment
- Rapid Charger allows for continuous runtime between two HD12.0 batteries
- Lug Nut Mode prevents over-torque by automatically shutting tool off once torqued within 350-450 ft.-lbs
- Quickly enable Lug Nut Mode within the One-Key™ App
- Unmatched productivity with the runtime to remove & install up to 120 lug nuts on a single High Output™ HD12.0Ah battery
- 4-Mode Drive Control™ provides greater control over output speed and power
- One-Key™ technology provides ability to customize, track and manage tools for increased productivity and investment protection, and includes the ability to set a repeatable torque output for maximum control
- A patented battery isolation system manages high frequency vibrations, enabling battery movement that prevents damage and ensures a constant connection between the battery and tool when in use
- Tri-LEDs deliver high definition lighting to increase workspace visibility with less shadows
- 360° adjustable and removable side handle
- Included lanyard loop allows for safer use and easier storage
- Redlink Plus™ Intelligence ensures maximum performance and protects from overloads, heating and over-discharge
- Premium rubber overmold withstands corrosive materials and provides increased comfort when in use
- Compatible with all M18™ batteries
- Includes: (1) M18 Fuel™ D-Handle Extended Anvil High Torque Impact Wrench with One-Key™, (1) Tool-free adjustable handle, (1) Lanyard loop, (2) M18 RedLithium™ HIGH OUTPUT™ HD12.0 Battery packs, (1) M18™ & M12™ Rapid battery charger, (1) Carrying case
- Manufacturer's Warranty: 2 Years



SPECIFICATIONS

Voltage:	18 V
Socket Size:	1"
Battery Type:	Lithium-Ion
Max Torque:	2000 ft.-lbs
No Load RPM:	1200
IPM:	1440
Tool Weight:	23.2 lbs.

Model No. UAK078
Mfg. No. 2869-22HD
Price/Each \$1964.00



M18 FUEL™ MID-TORQUE IMPACT WRENCH WITH FRICTION RING KIT

- Friction ring (hog ring) ensures quick and easy socket changes
- Faster removal speed provides increased user productivity
- 4-Mode Drive Control™ provides greater control over output speed and power, and includes auto shut-off and bolt-removal mode
- Bolt removal control delivers full torque output, then decreases RPMs once the bolt is loosened to prevent fastener drops
- Works in up to 69 kV environments
- 6.0" in length provides most access in tight spaces
- Tri-LEDs deliver high definition lighting to increase workspace visibility with less shadows
- Auto Shut-Off™ control applies no more than 35 ft.-lbs of torque for hand-tight fastening applications to prevent overtightening
- RedLink Plus™ Intelligence ensures maximum performance and protects from overloads, heating and over-discharge
- Compatible with all M18™ batteries & chargers
- Includes: (1) M18 Fuel™ 3/8" Mid-Torque Impact Wrench with Friction Ring (2960-20), (2) M18™ RedLithium™ XC5.0 Resistant Battery (48-11-1850R), (1) M18™ & M12™ Multi-Voltage Charger (48-59-1812), (1) Blow Molded Case

SPECIFICATIONS

Voltage:	18 V
Socket Size:	3/8"
Battery Type:	Lithium-Ion
Max Torque:	600 ft.-lbs
No Load RPM:	3100
IPM:	3100

Model No. UAV815
Mfg. No. 2960-22R
Price/Each \$731.00



CANADA'S LEADING MATERIAL HANDLING SUPPLIER

M18 FUEL™ MID-TORQUE IMPACT WRENCH WITH PIN DETENT KIT

- Pin detent locks sockets in place securely, especially while working overhead
- The PowerState™ brushless motor delivers up to 550 ft.-lbs. of max fastening torque
- 4-Mode Drive Control™ provides greater control over output speed and power. Includes auto shut-off and bolt-removal control
- Bolt removal control delivers full torque output, then decreases RPMs once the bolt is loosened to prevent fastener drops
- Works in up to to 69 kV environments
- 6.0" in length provides most access in tight spaces
- Tri-LEDs deliver high definition lighting to increase workspace visibility with less shadows
- Auto Shut-Off™ control applies no more than 35 ft.-lbs of torque for hand-tight fastening applications to prevent overtightening
- RedLink Plus™ Intelligence ensures maximum performance and protects from overloads, heating and over-discharge
- Compatible with all M18™ batteries & chargers
- Includes: (1) M18 Fuel™ 1/2" Mid-Torque Impact Wrench with Pin Detent (2962P-20), (2) M18™ RedLithium™ XC5.0 Resistant Battery (48-11-1850R), (1) M18™ & M12™ Multi-Voltage Charger (48-59-1812), (1) Blow Molded Case



SPECIFICATIONS

Voltage:	18 V
Socket Size:	1/2"
Battery Type:	Lithium-Ion
Max Torque:	650 ft.-lbs
No Load RPM:	2575
IPM:	3100

Model No. UAV817
Mfg. No. 2962P-22R
Price/Each \$654.00



M18 FUEL™ UTILITY HIGH TORQUE IMPACT WRENCH WITH ONE-KEY™ KIT

- Ergonomically designed for the lineman, providing you with superior control whether in-bucket, on-ground or climbing
- Designed with an extended handle to fit high voltage safety gloves for superior grip
- Quik-Lok™ technology enables one-handed bit insertion
- One-Key™ technology enables the user to customize, track and manage their tool
- RedLink Plus™ intelligence ensures maximum performance and protects from overloads, heating and over-discharge
- Includes: (1) M18™ Fuel™ Utility High Torque Impact Wrench with One-Key™, (2) M18™ RedLithium™ XC5.0 Extended capacity battery pack, (1) M18™ & M12™ Multi-voltage charger, (1) Contractor Bag, (1) Inverter

SPECIFICATIONS

Voltage:	18 V
Socket Size:	7/16"
Battery Type:	Lithium-Ion
Max Torque:	750 ft.-lbs
No Load RPM:	1300

Model No. UAF083
Mfg. No. 2865-22
Price/Each \$915.00



M18 FUEL™ COMPACT IMPACT WRENCH WITH FRICTION RING KIT

- 4.9" length provides most access in tight spaces
- The Powerstate™ brushless motor delivers up to 250 ft.-lbs. of nut-busting torque
- Tri-LEDs deliver high definition lighting to increase workspace visibility with less shadows
- 4-Mode Drive Control™ provides greater control over output speed and power. Includes auto shut-off and bolt-removal mode
- Auto shut-off mode prevents over tightening and increases productivity by applying no more than 20 ft.-lbs. of torque
- Bolt-removal mode offers more control after bolt breakaway as RPMs drastically slow down once the bolt is loosened
- Redlink Plus™ Intelligence ensures maximum performance and protects from overloads, heating and over-discharge
- Works in up to to 69 kV environments
- Compatible with all M18™ batteries & Chargers
- Includes: M18 Fuel™ 1/2" Compact impact wrench with friction ring (2855-20), (2) M18™ RedLithium™ XC5.0 Resistant batteries (48-11-1850R), (1) M18™ & M12™ Multi-voltage charger (48-59-1812), (1) Blow molded case



SPECIFICATIONS

Voltage:	18 V
Socket Size:	1/2"
Battery Type:	Lithium-Ion
Max Torque:	250 ft.-lbs
No Load RPM:	2400
IPM:	3500

Model No.	Mfg. No.	Desc.	Price/Each
UAK139	2855-20	Tool Only	326.00
UAV745	2855-22R	Tool & Kit	567.00



M18 FUEL™ MID-TORQUE IMPACT WRENCH WITH FRICTION RING KIT

- Friction ring (hog ring) ensures quick and easy socket changes
- Faster removal speed provides increased user productivity
- 4-Mode Drive Control™ provides greater control over output speed and power, and includes auto shut-off and bolt-removal mode
- Bolt removal control delivers full torque output, then decreases RPMs once the bolt is loosened to prevent fastener drops
- Works in up to to 69 kV environments
- 6.0" in length provides most access in tight spaces
- Tri-LEDs deliver high definition lighting to increase workspace visibility with less shadows
- Auto Shut-Off™ control applies no more than 35 ft.-lbs of torque for hand-tight fastening applications to prevent overtightening
- RedLink Plus™ Intelligence ensures maximum performance and protects from overloads, heating and over-discharge
- Compatible with all M18™ batteries & chargers
- Includes: (1) M18 Fuel™ 1/2" Mid-Torque Impact Wrench with Friction Ring Kit (2962-22R), (2) M18™ RedLithium™ XC5.0 Resistant Battery (48-11-1850R), (1) M18™ & M12™ Multi-Voltage Charger (48-59-1812), (1) Blow Molded Case



SPECIFICATIONS

Voltage:	18 V
Socket Size:	1/2"
Battery Type:	Lithium-Ion
Max Torque:	650 ft.-lbs
No Load RPM:	2575
IPM:	3100

Model No.	Mfg. No.	Desc.	Price/Each
UAK137	2962-20	Tool Only	381.00
UAV816	2962-22R	Tool & Kit	731.00





M12 FUEL™ HEX IMPACT DRIVER KIT

- Powerstate™ Brushless Motor has up to 1,500 in.-lbs. of torque
- Compact driver is 5" in length for most access in tight spaces
- Tri-LEDs has brighter lights allowing max workspace visibility
- Powerstate™ Brushless Motor delivers up to 1,500 in.-lbs. of torque
- Only 5" in length for most access in tight spaces
- Tri-LED illuminates workspace
- 4-Mode drive control with dedicated self tapping screw mode
- Light Weight at 2 lbs for tool belt portability and less fatigue in the work day
- Single-handed bit insertion for ease of use
- Redlink Plus intelligence provides the ability to drive more fasteners back to back
- All-metal belt clip for portability
- Compatible with Milwaukee Accessory Bit Holder 49-16-3697
- Compatible with all M12™ batteries & chargers

SPECIFICATIONS

Voltage:	12 V
Chuck Size:	1/4"
Battery Type:	Lithium-Ion
Max Torque:	1500 in.-lbs
No Load RPM:	3600

Model No.	Mfg. No.	Desc.	Price/Each
UAV635	3453-20	Tool Only	190.00
UAV636	3453-22	Tool & Kit	238.00



M12 FUEL™ HEX IMPACT DRIVER PROTECTIVE BOOT

- Flexible material allows for easy install and removal
- Adds minimal size or weight to the tool
- Not made for use on or near live electrical circuits
- Best in class performance
- Durable proprietary rubber designed to withstand corrosive materials commonly found in maintenance environments
- Made with Non-Marring Rubber
- Compatible with the M12 Fuel Impact Driver 3453
- Form-fitting, lightweight design
- Withstands corrosive materials

Model No. UAV637
Mfg. No. 49-16-3453
Price/Each \$34.40



M18 FUEL™ HEX IMPACT DRIVER KIT

- Powerstate™ Brushless motor delivers unmatched power
- Increase productivity with the fastest impact driver speed
- Trigger control provides smooth acceleration for small fasteners
- Powerstate™ Brushless motor delivers unmatched power for full range of capability to complete the widest variety of applications
- Increase productivity on the jobsite with the fastest driving speed of any impact driver without sacrificing power or control
- Ultimate trigger control by providing smooth acceleration for small fasteners to prevent stripping of screws or damaging of materials
- Tri-LED Lighting for maximum workspace visibility
- Compact Size (4.47") for access in tight spaces
- 4-Mode drive control
- All-metal belt clip for portability
- Includes: (1) M18 Fuel™ 1/4" Hex Impact Driver, (2) M18™ RedLithium™ XC5.0 Extended Capacity Battery Pack, (1) M18™ & M12™ Multi-Voltage Charger, (1) Blow Molded Case, (1) Belt Clip

SPECIFICATIONS

Voltage:	18 V
Chuck Size:	1/4"
Battery Type:	Lithium-Ion
Max Torque:	2000 in.-lbs
No Load RPM:	3900

Model No.	Mfg. No.	Desc.	Price/Each
UAV650	2953-20	Tool Only	249.00
UAV651	2953-22	Tool & Kit	439.00



XTREME™ BRUSHLESS IMPACT DRIVER KIT

- Ideal for precision fastening applications
- Brushless motor for Maximum runtime and durability
- 3-mode settings including the Precision Drive™ feature for accuracy
- Quick release drop and load hex that accepts 1" bit tips
- 3 LED lights on nose for work surface illumination
- Includes: (1) 12 V Max* brushless 1/4" impact driver, (2) 12 V Max* 2 Ah batteries with state of charge indicator, (1) 12 V and 20 V Max* charger, (1) Belt clip, (1) Kit bag

SPECIFICATIONS

Voltage:	12 V
Chuck Size:	1/4"
Max Torque:	1450 in.-lbs
No Load RPM:	0-2850

Model No.	Mfg. No.	Desc.	Price/Each
UAF548	DCF801B	Tool Only	165.00
UAF543	DCF801F2	Tool & Kit	225.00



XR® 3-SPEED IMPACT DRIVER

- Delivers 1825 in.-lbs of torque and 3400 RPM to drive large diameter screws
- Complete tough fastening applications on the jobsite with 30% more torque
- Pro-level control and precision with variable speed trigger and 3-speed setting
- This product is a Chip Ready™ tool for seamless integration into the Tool Connect™ system (chip sold separately)
- Brighten work areas with an integrated 3-LED work light for enhanced visibility in low-light areas
- Manufacturer's Warranty: 3-Year Limited Warranty
- Includes: (1) Impact Driver, (1) Belt Hook

SPECIFICATIONS

Voltage:	20 V
Chuck Size:	1/4"
Battery Type:	Lithium-Ion
No Load RPM:	3400
Impact Rate per Minute:	4200

Model No.	Mfg. No.	Desc.	Price/Each
AUW238	DCF845B	Tool Only	269.00



ATOMIC BRUSHLESS CORDLESS 3-SPEED IMPACT DRIVER

- Compact, under 4 in. design for optimized ergonomics and access to difficult-to-reach spots
- Delivers 1825 in.-lb of torque and 3250 RPM to drive large-diameter screws
- Pro-level control and precision with a variable 3-speed trigger
- Illuminate dim workspaces for enhanced visibility with the 3-LED on-board work light and keep your workflow consistent
- Manufacturer's Warranty: 3-Year Limited Warranty
- Includes: (1) Impact Driver, (1) Belt Hook

SPECIFICATIONS

Voltage:	20 V
Chuck Size:	1/4"
Battery Type:	Lithium-Ion
Max Torque:	1825 in.-lbs
No Load RPM:	3250

Model No.	Mfg. No.	Desc.	Price/Each
AUW233	DCF850B	Tool Only	235.00



M12 FUEL™ RATCHET 2 BATTERY KIT

- Low profile head design allows for more access in tight spaces
- FUEL™ technology and investment cast steel yoke housing provides greater durability
- POWERSTATE™ brushless motor delivers up to 2x longer motor life
- Premium rubber overmold withstands corrosive materials and provides increased comfort when in use
- LED light illuminates the work area while the on-board fuel gauge displays remaining run time
- RedLithium™ batteries deliver more work per charge
- Compatible with all M12 battery packs
- Compatible with all M12 chargers
- Includes: M12 FUEL™ Ratchet tool, (2) M12 RedLithium™ 2.0 Battery, M12 Lithium-ion Battery Charger, Carrying Case
- Handle: Rubber



M12™ RIVET TOOL KIT

- Pulls up to 3/16" stainless steel rivets
- Tool holds rivet in any orientation
- Material Capacity: Aluminum, Steel, Stainless Steel
- Pull Force: 2000 lbs.
- Stroke Length: 0.8"
- Nose Piece Size: 3/32", 1/8", 5/32", 3/16"
- Includes: (1) M12™ Rivet Tool (Tool Only)(2550-20), (2) M12™ REDLITHIUM™ CP1.5 Battery Pack (48-11-2401)

Model No. UAF503
Mfg. No. 2550-22
Price/Each \$543.00



M18 FUEL™ 1/4" BLIND RIVET TOOL WITH ONE-KEY™ KIT

- Up to 50% faster than cordless competitors
- Eliminates compressors and hoses providing lower cost of ownership, greater productivity, more portability and more safety
- Installs up to 500 1/4" aluminum blind rivets on one RedLithium™ CP2.0 battery charge
- Only 12.5" in length including the mandrel collector
- Premium rubber over-mold withstands corrosive materials and provides increased comfort when in use
- Maximum tool and jaw durability provide up to 3X longer life
- Installs 3/16" (4.8mm), 7/32" (6.0mm), 1/4" (6.4mm) and 9/32" (7.0mm) aluminum, steel, and stainless steel rivets
- PowerState™ Brushless Motor delivers 4 500 lbs. (20 kN) of pulling force for high strength blind rivets in all materials
- Weighs only 5.6 lbs. with RedLithium™ 2.0 Ah battery
- One-Key™ Compatible: Ability to track and manage tools for increased productivity and investment protection
- Compatible with all M18™ batteries and chargers
- Includes: M18 Fuel™ 1/4" Blind rivet tool with One-Key™, (2) M18™ RedLithium™ CP2.0 battery, (1) M18™ & M12™ Multi-voltage charger, (1) M18 Fuel™ 1/4" Blind rivet tool with One-Key™ retention nose piece 4-pack, (1) Nose piece wrench, (1) Mandrel collector, (1) Hanging ring, (1) Belt clip, (1) Contractor bag

Model No. UAK821
Mfg. No. 2660-22CT
Price/Each \$1581.00



Model No.	Mfg. No.	Max Torque ft-lbs	Drive Size"	Overall Length"	Max RPM	Price /Each
TY023	2557-22	55	3/8	12	200	411.00
TY026	2558-22	60	1/2	12-1/2	175	412.00

M12™ CORDLESS RATCHET KIT

- Features a 3/4" low-profile head design for work in the tightest of spaces and engine bays
- The variable-speed metal trigger and reinforced steel housing provide maximum control and durability with any application
- REDLINK™ Intelligence provides optimized performance and overload protection using total system communication between tool, battery and charger
- Includes: (1) M12™ Cordless 3/8" Ratchet (2457-20), (1) M12™ RedLithium™ CP1.5 Battery Pack (48-11-2401), and (1) M12™ Lithium-ion Battery Charger (48-59-2401)
- Voltage: 12 V
- Peak Torque: 35 ft-lbs.
- Head Width: 3/4"
- No Load RPM: 0-250
- Drive: 3/8"

Model No. TMB765
Mfg. No. 2457-21
Price/Each \$266.00



MX FUEL™ BREAKER KIT

- LED lights provide light at the chisel in dark applications
- Front handle for easier transportation and maneuvering throughout the job site
- Anti-vibration body limits excess vibration and provides a comfortable grip while operating
- Features 1-1/8" hex tool holder
- One-Key™ technology allows for customization, tracking, tool security, and inventory management
- 40' trench per charge
- Features soft start and service indicator light
- Includes: (1) Cart, (3) Chisels, (1) MX Fuel™ breaker, (1) MX Fuel™ RedLithium™ XC406 battery pack, (1) MX Fuel™ charger
- Chuck Size: 1-1/8"
- Chuck Type: Hex
- Impact Energy: 50 ft-lbs
- Blows/Min.: 1300 BPM
- Vibration Level: 4.9 m/s²
- Length: 32.2"
- Width: 25.1"
- Height: 11.6"
- Weight: 63.9 lbs.

Model No. UAI576
Mfg. No. MXF368-1XC
Price/Each \$3489.00



M18™ FORCE LOGIC™ 750 MCM CRIMPER KIT

- Includes: M18™ Force Logic™ 750 MCM crimper, M18™ RedLithium™ CP2.0 battery, M18™ RedLithium™ XCS.0 extended capacity battery pack, M18™ & M12™ multi-voltage charger, Carry case
- Capacity: #8 – 750 MCM Cu/Al

Model No. UAF089
Mfg. No. 2779-22
Price/Each \$6364.00



CORDLESS POWER TOOLS



M18 FUEL™ NO-LOCK BRAKING GRINDER & BATTERIES KIT

- Rapid Stop braking feature stops all accessories in 3 seconds or less
- Make all accessory changes and guard adjustments without a wrench for increased productivity
- Redlink Plus™ Intelligence provides optimized performance and overload protection using total system communication between tool, battery and charger
- Paddle switch
- Includes: (1) M18™ Fuel™ 4-1/2" - 6" Braking Grinder Paddle Switch, No-Lock (2980-20), (2) M18 Redlithium™ High Output™ XC6.0 Battery Packs (48-11-1865), (1) M18™ & M12™ Rapid Charger (48-59-1808), (1) FIXTEC Nut, (1) T27 Guard, (1) Back Flange, (1) Wrench, (1) Side Handle

SPECIFICATIONS

Voltage: 18 V
Wheel Size: 4-1/2", 6"
Battery Type: Lithium-Ion
No Load RPM: 9000



Model No.	Mfg. No.	Desc.	Price/Each
UAE129	2980-20	Tool Only	358.00
UAE131	2980-22	Tool & Kit	719.00

M18 FUEL™ NO-LOCK BRAKING GRINDER WITH ONE-KEY™ PADDLE SWITCH

- Powerstate™ Brushless Motor is purposely built for the M18 Fuel™ 4-1/2" / 5" Braking Grinder with One-Key™ and delivers 8500 RPM to provide the power to complete the toughest grinding and cutting applications
- Redlink Plus™ Intelligence is the most advanced system of electronics in the industry, enabling communication between batteries and tools, allowing for unmatched levels of performance, protection, and compatibility
- Redlithium™ High Output™ Battery Pack (not included) provides 50% more power and runs 50% cooler versus standard Redlithium™ Battery
- Includes a RapidStop™ Brake, to quickly stop accessories and enhance safety
- Paddle switch design for increased comfort and ease-of-use when operating in various positions
- Tool-free guard adjustment for faster guard installations and adjustments
- Tool-free accessory changes with integrated Fixtec nut technology
- Electronic clutch for kickback protection
- 5/8"-11 spindle for use with common grinding accessories
- Overload protection to maximize motor life
- Anti-vibration side handle for increased user comfort and safety
- One-Key™ tracking and tool management
- Includes: (1) M18 Fuel 4-1/2" / 5" Braking Grinder with One-Key™ Paddle Switch (No Lock), (1) Spanner wrench, (1) Type 27 guard, (1) Type 1 guard, (1) Side handle

SPECIFICATIONS

Voltage: 18 V
Wheel Size: 4-1/2", 5"
Battery Type: Lithium-Ion
No Load RPM: 8500



Model No.	Mfg. No.	Desc.	Price/Each
TCT637	2882-20	Tool Only	325.00

GRINDER TOOL KIT

- 7,000 RPM motor provides high-power for cutting and grinding applications
- Tool-free guard allows for quick and easy guard adjustments/positioning
- 2-position side handle offers greater control, comfort and versatility
- Quick-change wheel release allows for tool-free wheel changes without the need for a wrench
- 2-finger trigger switch (with lock-off button) allows for convenient activation and easier gripping
- Includes: Grinder, (2) Lithium-ion Batteries (5.0 Ah), Fast Charger, Spanner Wrench, Type 27 (Grinding) Guard, and Contractor Bag



Model No.	Mfg. No.	Desc.	Price/Each
TLV785	DCG412B	Tool Only	235.00
TYL318	DCG412P2	Tool & Kit	499.00

MAX XR® SMALL ANGLE GRINDER WITH KICKBACK BRAKE KIT

- Includes: Max XR® Small angle grinder, Side handle, Hex key, Inner and outer flange, 4-1/2" Type 27 guard, (2) 20 V/6 Ah batteries, (1) Battery charger, (1) Kit bag
- Voltage: 20 V
- Wheel Size: 4-1/2"
- Battery Type: Lithium-Ion



Model No.	Mfg. No.	Desc.	Price/Each
UAE521	DCG413B	Tool Only	315.00
UAE522	DCG413R2	Tool & Kit	635.00

M18™ BRUSHLESS CUT-OFF GRINDER WITH PADDLE SWITCH

- Brushless motor was built and optimized specifically for cutting and surfacing applications
- Redlithium™ batteries (not included) deliver more work per charge and more work over the life of the battery
- REDLINK™ Intelligence: Advanced overload protection defends against abusive applications and monitors the temperature to prevent damage and ensure maximum tool & battery life
- Paddle switch design for increased comfort and ease-of-use when operating in various positions
- Tool-free guard adjustment for faster guard installations and adjustments
- 5/8"-11 spindle for use with common grinding accessories
- Electronic clutch for kickback protection
- Over protection maximizes motor life
- Compatible with all M18™ batteries
- Paired with built-in REDLINK™ power tool technology and Redlithium™ batteries, the Brushless Grinder provides efficient power delivery and longer battery life resulting in up to 80 cuts in 1/2" rebar
- The compact and light build allows for excellent control and comfort
- Built to last, with an all-metal gear case
- Material Applications: Aluminum, Ceramic Tile, Steel
- Includes: M18™ Brushless 4-1/2" / 5" Cut-Off Grinder, Paddle Switch (2686-20), Type 1 Guard, Type 27 Clip-On Guard, Side Handle, Back Flange, Flange Nut, Wrench

SPECIFICATIONS

Voltage: 18 V
Wheel Size: 4-1/2", 5"
Battery Type: Lithium-Ion
No Load RPM: 11 000



Model No.	Mfg. No.	Desc.	Price/Each
AUW182	2686-20	Tool Only	229.00

M18 FUEL™ PADDLE SWITCH NO-LOCK GRINDER

- PowerState™ Brushless Motor purposely built to provide the power to complete the toughest grinding and cutting applications
- Redlink Plus™ Intelligence - enables communication between batteries and tools, allowing for unmatched levels of performance, protection, and compatibility
- Redlithium™ High Output™ Battery Pack (not included) provides 50% more power and runs 50% cooler versus standard Redlithium™ Battery
- Paddle switch design for increased comfort and ease-of-use when operating in various positions
- Tool-free guard adjustment for faster guard installations and adjustments
- Tool-free accessory changes with integrated FIXTEC Nut Technology
- Electronic clutch for kickback protection
- 5/8"-11 spindle for use with common grinding accessories
- Overload protection to maximize motor life
- Anti-vibration side handle for increased user comfort and safety

SPECIFICATIONS

Voltage:	18 V
Amps:	11 A
Wheel Size:	4-1/2", 5"
Battery Type:	Lithium-Ion
No Load RPM:	8500



Model No.	Mfg. No.	Desc.	Price/Each
UAK826	2880-20	Tool Only	304.00

M18 FUEL™ SLIDE SWITCH LOCK-ON GRINDER

- PowerState™ Brushless Motor purposely built to provide the power to complete the toughest grinding and cutting applications
- Redlink Plus™ Intelligence - enables communication between batteries and tools, allowing for unmatched levels of performance, protection, and compatibility
- Redlithium™ High Output™ Battery Pack (Not Included) provides 50% more power and runs 50% cooler versus standard Redlithium™ Battery
- Slide switch designed to reduce user fatigue
- Tool-free guard adjustment for faster guard installations and adjustments
- Tool-free accessory changes with integrated FIXTEC Nut Technology
- Electronic clutch for kickback protection
- 5/8"-11 spindle for use with common grinding accessories
- Overload protection to maximize motor life
- Anti-vibration side handle for increased user comfort and safety

SPECIFICATIONS

Voltage:	18 V
Amps:	11 A
Wheel Size:	4-1/2", 5"
No Load RPM:	8500



Model No.	Mfg. No.	Desc.	Price/Each
UAK828	2881-20	Tool Only	304.00

M18™ FUEL™ LARGE ANGLE GRINDER

- Redlithium™ battery helps this tool deliver 15 A of corded power
- At up to 2 lbs. lighter than regular corded grinders, this tool reduces fatigue and increases productivity
- Features Redlink Plus™ intelligence, providing optimized performance, electronic clutch, and overload protection by using system communication between the tool, battery, and charger



Model No.	Mfg. No.	Desc.	Price/Each
UAE128	2750-20	Tool Only	435.00

M12 FUEL™ STRAIGHT DIE GRINDER KIT

- Powerstate™ brushless motor
- Features 3-mode speed control and a responsive variable-speed trigger
- Optimized for most common 2" accessories
- No air hoses, compressors, or daily maintenance
- Compact tool size allows access in tight spaces
- Includes: (1) M12 Fuel™ 1/4" straight die grinder, (2) M12™ Redlithium™ CP2.0 batteries, (1) M12™ lithium-ion battery charger, (1) Carrying case, (2) Wrenches



Model No.	Mfg. No.	Desc.	Price/Each
UAJ223	2486-20	Tool Only	293.00
UAJ224	2486-22	Tool & Kit	402.00

M18 FUEL™ BRAKING DIE GRINDER

- Powerstate™ Brushless Motor provides more power, more run-time, and longer life
- Redlink Plus™ Intelligence enables communication between batteries and tools, allowing for unmatched levels of performance, protection, and compatibility
- Rapidstop™ Brake stops cutting and sanding accessories in under 2 seconds
- Features spindle lock one-wrench accessory change, and slide switch designed to reduce user fatigue
- Designed to deliver corded performance with 2" accessory sanding and cutting wheel compatibility
- Compatible with all M18™ batteries
- Delivers up to 12" of weld bead removed per charge
- Power to remove weld beads, surface prep, deburr pipes, and small cutting applications
- Manufacturer's Warranty: 5-year Limited Warranty
- Motor Type: Powerstate™ Brushless
- Handle Type: Barrel Grip



SPECIFICATIONS

Voltage:	18 V
Collet Size:	1/4"
Wheel Diameter:	1/4"
Battery Type:	Lithium-Ion
No Load RPM:	27 0000

Model No.	Mfg. No.	Desc.	Price/Each
UAV750	2939-20	Tool Only	348.00

M12 FUEL™ RIGHT ANGLE DIE GRINDER KIT

- PowerState™ brushless motor
- 4-Mode speed control and responsive variable-speed trigger
- Includes: (1) M12 Fuel™ 1/4" Right Angle Die Grinder, (2) M12™ Redlithium™ CP2.0 battery packs, (1) M12™ Lithium-ion battery charger, (1) Carrying case, (2) Wrenches



SPECIFICATIONS

Voltage:	12 V
Collet Size:	1/4"
Battery Type:	Lithium-Ion
No Load RPM:	25 0000
Power:	0.3 HP

Model No.	Mfg. No.	Desc.	Price/Each
UAI589	2485-22	Tool & Kit	402.00

CORDLESS POWER TOOLS

M18 FUEL™ 7-1/4" CIRCULAR SAW KIT

- Powerstate™ brushless motor increased cutting speed and power through the toughest applications
- Redlink Plus™ intelligence provides optimized performance and overload protection using total system communication between tool, battery and charger
- LED light for great cutline visibility in low light situations
- Includes: (1) M18™ Redlithium™ XC 5.0 extended capacity battery pack, (1) M18™ & M12™ multi-voltage charger, (1) blade, (1) blade wrench, (1) contractor bag

Milwaukee

SPECIFICATIONS

Voltage:	18 V
Blade Size:	7-1/4"
Battery Type:	Lithium-Ion
No Load RPM:	5000



Model No.	Mfg. No.	Desc.	Price/Each
UAE138	2732-20	Tool Only	370.00
TYX081	2732-22	Tool & Kit	642.00

M18 FUEL™ CIRCULAR SAW

- POWERSTATE™ brushless motor out-powers all other 18V cordless circular saws and provides up to 3x longer tool life
- REDLINK PLUS™ intelligence is the most advanced electronic system on the market and maximizes performance
- LED Light: Yes
- Maximum Bevel Capacity: 50 degrees
- Tool Warranty: 5 years

Milwaukee

SPECIFICATIONS

Voltage:	18 V
Blade Size:	6-1/2"
Battery Type:	Lithium-Ion
No Load RPM:	5000



Model No.	Mfg. No.	Desc.	Price/Each
TYD878	2730-20	Tool Only	316.00

MAX XR® BRUSHLESS CIRCULAR SAW KIT

- Brushless motor Maximizes runtime and durability
- Optimizes line of sight with a left-side blade and rear handle for smooth, accurate cuts
- An electronic brake helps stop the blade after releasing trigger to increase protection
- Ideal for oriented strand board (OSB), plywood, hardwoods, dimensional lumber, and flooring
- High-grade magnesium shoe
- Tool Connect™ Tag-Ready™ for easy tool tracking (Tool Connect Tag sold separately)
- Includes: 7-1/4" Circular saw, 7-1/4" Blade, Blade changing wrench, 20 V Lithium-ion battery, 12 V/20 V Max lithium-ion battery charger, Rafter hook

DEWALT

SPECIFICATIONS

Voltage:	20 V
Blade Size:	7-1/4"
Battery Type:	Lithium-Ion
No Load RPM:	5500



Model No.	Mfg. No.	Desc.	Price/Each
UAE530	DCS570B	Tool Only	329.00
UAI766	DCS570P1	Tool & Kit	509.00

REAR HANDLE CIRCULAR SAW

Makita

- Automatic torque Drive Technology (ADT) feature adjusts the torque and speed according to the load condition, enabling rapid movement between high speed and high torque applications
- Lightweight design with magnesium baseplate and blade case
- Large integrated tool hanger provides convenience on the jobsite and fits 4" x 4" material
- Electric brake stops blade 3 - 5 seconds after trigger is released for increased operator safety
- Soft start feature gradually increases speed to eliminate start up shock
- Brushless DC motor with high power to weight and size ratio generates less heat buildup and is ideal for prolonged use in manufacturing and production applications
- The eXtreme Protection Technology (XPT) offers Maximum protection against dust, debris and liquids for optimal performance in extreme conditions
- Bevel capacity of 0° - 53° with positive stops at 22.5° and 45°

SPECIFICATIONS

Voltage:	18 V
Blade Size:	7-1/4"
Battery Type:	Lithium-Ion
No Load RPM:	5100



Model No.	Mfg. No.	Desc.	Price/Each
UAE979	DRS780Z	Tool Only	395.00

M18 FUEL™ METAL CUTTING CIRCULAR SAW

- Brushless motor runs cooler, lasts longer and delivers up to 55% faster application speed
- Redlink Plus™ Electronic Intelligence allows the operator to choose between 3 fastening modes with Milwaukee's proprietary Drive Control™ feature
- Brushless motor has no wearables components delivering longest tool life
- Integrated hang hook allows tool to hang on ladders and common building materials reducing damage due to drops

Milwaukee

SPECIFICATIONS

Voltage:	18 V
Blade Size:	5-3/8"
Battery Type:	Lithium-Ion
No Load RPM:	3600



Model No.	Mfg. No.	Desc.	Price/Each
TLV562	2782-20	Tool Only	307.00

M12 FUEL™ BAND FILE

- The first cordless band file that delivers pneumatic performance, size, and features for professional automotive, industrial, and metalworking users
- Powerstate™ Brushless Motor delivers the power to remove spot welds with the best-in-class material removal rate
- Two-speed settings, forward & reverse functionality
- Lock-on button, variable speed trigger
- Tool-free 360° arm rotation
- Eliminates hoses and compressors
- Replaceable contact wheel
- Includes: (1) Band File, (2) 60 Grit Sanding Belts

Milwaukee

SPECIFICATIONS

Voltage:	12 V
Surface Feet per Minute:	1800-3600



Model No.	Mfg. No.	Description	Belt Size"	Price /Each
UAV718	2482-20	Tool Only	1/2 W x 18 L	334.00
UAV719	2483-20	Tool Only	3/8 W x 13 L	334.00

M18 FUEL™ CORDLESS DEEP CUT BAND SAW

- Powerstate™ brushless motor increases cutting speed and power through the toughest applications
- CPT™ Constant Power Technology maintains cut speed in the toughest applications for optimal performance
- The Jobsite Armor Technology™ proprietary composite material and crush zone barriers provide long lasting rugged protection
- Jobsite Armor Technology™ proprietary composite material and crush zone barriers provide long lasting rugged protection
- All metal direct drive delivers maximum tool life with all metal direct drive gearing system, while requiring less servicing than a chain drive
- Button actuated tool-free design allows user to quickly adjust from an extended shoe to no shoe in seconds
- Button actuated tool-free locking adjustable shoe design allows user to quickly adjust from an extended shoe to no shoe in seconds
- LED light illuminates work surface for increased accuracy and productivity
- Dual-actuation trigger provides enhanced control and productivity
- Over 90% same parts as Milwaukee's Corded Deep Cut Band Saw
- Redlink Plus™ Intelligence, the most advanced system of cordless power tool electronics, provides optimized performance and overload protection using total system communication between tool, battery and charger
- Versatility to cut up to 5" x 5" material in one pass and adjustable shoe allows for less tool rotation when cutting material above 5"
- Redlithium™ XC5.0 battery provides superior pack construction, more work per charge and more work over the life of the pack than competitive batteries
- Blade Dimensions: 44-7/8" x 1/2" x .020"
- Manufacturer's Warranty: 5 Year Limited

SPECIFICATIONS

Voltage:	18 V
Cutting Capacity at 90°:	5"
Battery Type:	Lithium-Ion
Blade Speeds:	0 - 380 FPM
Tool Weight:	15 lbs.

Model No.	Mfg. No.	Desc.	Price/Each
NKI035	2729-20	Tool Only	516.00



BAND SAW KIT

- Integrated hang hook allows user to hang the saw without damaging the front handle or base
- Tool-less blade changing lever loosens blade tension for easy blade changes
- LED work light with 20 second delay illuminates dark work surfaces for accurate cutting
- Variable speed for versatility and control
- Includes one band saw, two batteries, one charger, one kit box and one band saw blade



SPECIFICATIONS

Voltage:	20 V
Cutting Capacity at 90°:	4-3/4"
Battery Type:	Lithium-Ion
Blade Speeds:	0 - 490 FPM
Battery Capacity:	5.0 Ah

Model No.	Mfg. No.	Desc.	Price/Each
UA529	DCS374B	Tool Only	565.00
UAD956	DCS374P2	Tool & Kit	985.00



M18 FUEL™ COMPACT BAND SAW KIT

- Powerstate™ brushless motor delivers fast cutting speed
- Conduit reamer attaches directly to back of the tool (sold separately)
- Constant Power Technology™ maintains cut speed in the toughest applications for optimal performance
- Jobsite Armor Technology™ proprietary composite material and crush zone barriers provide long lasting rugged protection
- Variable speed trigger provides Maximum speed control
- LED light illuminates work surface for increased accuracy and productivity
- RedLink Plus™ Intelligence provides optimized performance and overload protection using total system communication between tool, battery and charger
- Delivers Maximum tool life with all metal direct drive gearing system, while requiring less servicing than a chain drive
- Tool-free locking adjustable shoe
- Includes: (1) Extreme thick metal 8/10 TPI band saw blade, (2) M18™ Redlithium High Output™ CP3.0 batteries, (1) M18™ & M12™ rapid charger, (2) Compact band saw blade covers, (1) Contractor bag

SPECIFICATIONS

Voltage:	18 V
Cutting Capacity at 90°:	3-1/4"
Battery Type:	Lithium-Ion
Blade Speeds:	0 - 540 FPM

Model No.	Mfg. No.	Desc.	Price/Each
UAJ157	2829-20	Tool Only	435.00
UAJ158	2829-22	Tool & Kit	719.00



MX FUEL™ CUT OFF SAW KIT

- Delivers instant starts and zero emissions while providing you with no gas headaches, fastest cuts from start to finish, and can cut 6' of concrete or 72 cuts in #5 rebar per charge
- The MX Fuel™ Redlithium™ battery pack provides instant power with no gas headaches
- This results in the demo saw having fewer wearable parts, less noise and vibration, and zero emissions for a safer workspace indoors or outdoors
- The cordless cut off saw is compatible with all MX Fuel™ Redlithium™ batteries, giving you the hardest working and most reliable power for equipment
- The push-button activation eliminates the repetitive motions of a pull start and gives you the ability to cut materials faster from start to finish
- A full 14" capacity gives you the ability to cut up to 5" depths in a large variety of material
- The Powerstate™ brushless motor delivers the power to cut through a wide range of tough materials from concrete to rebar and ductile iron
- Redlink Plus™ Intelligence ensures optimal tool performance and provides overload protection to protect your machine and battery during the toughest applications
- The MX Fuel™ 14" Cut-Off Saw is One-Key™ compatible
- Includes: (1) Contractor bag, (1) Hex key, (1) MX Fuel™ 14" Cut-off saw, (2) MX Fuel™ Redlithium™ XC406 Battery Pack, (1) Quick connect collar, (1) Wrench, (1) MX Fuel™ Charger
- Manufacturer's Warranty: 2 Years

SPECIFICATIONS

Blade Size:	14"
Blade Arbor Size:	1" (20 mm)
Cut Depth:	5"
Battery Type:	Lithium-Ion
No Load RPM:	5350



Model No.	Mfg. No.	Desc.	Price/Each
TCT643	MXF314-2XC	Tool & Kit	3709.00



CORDLESS POWER TOOLS

LXT RECIPROCATING SAW

- eXtreme Protection Technology (XPT) offers Maximum protection against dust, dirt and debris for optimal performance in extreme conditions
- Vertical crank mechanism minimizes blade deflection and reduces vibration
- Fixed shoe provides Maximum stability during heavy-duty cutting applications
- Large 2-finger trigger switch for optimum control and comfort
- Ergonomic soft rubber grip designed for vibration absorption and comfortable operation

SPECIFICATIONS

Voltage:	18 V
Battery Type:	Lithium-Ion
Strokes per Minute (SPM):	0-2800
Stroke Length:	1-1/4"
Vibration Level:	13 m/s ²
Noise Level:	84 dB(A)



Model No.	Mfg. No.	Desc.	Price/Each
UAF068	DJR186Z	Tool Only	189.00



MAX RECIPROCATING SAW KIT

- 4-position blade clamp allows for flush cutting and increased positional versatility with tool-free blade changes
- Variable speed trigger provides blade control for precision cuts
- Pivoting adjustable shoe extends blade life and allows depth of cut control
- Rubber over molded comfort grip delivers optimal comfort and control
- Double oil sealed shaft resists contamination and increases durability
- Includes: 20 V Max reciprocating saw, 20 V Max XR[®] Premium lithium-ion 5.0 Ah battery, Charger, Kit box

SPECIFICATIONS

Voltage:	20 V
Battery Type:	Lithium-Ion
Strokes per Minute (SPM):	0-3000
Stroke Length:	1-1/8"
Tool Length:	18"
Tool Weight:	7.35 lbs.



Model No.	Mfg. No.	Desc.	Price/Each
TLV843	DCS380B	Tool Only	235.00
TYL331	DCS380P1	Tool & Kit	419.00

ATOMIC™ CORDLESS ONE-HANDED RECIPROCATING SAW

- This lightweight reciprocating saw is only 3.13 lbs. and 37% lighter than the DCS367 Compact Reciprocating Saw (Tool Only)
- This saw's LED helps illuminate dark workspaces and provides up to 2800 spm to help get the job done
- The pivoting shoe and variable speed trigger provide added control for a variety of jobs
- Battery and charger sold separately
- Variable-speed trigger provides user with improved speed control
- Tool-free blade release allows for quick and easy blade changes
- Manufacturer's Warranty: 3-Year Limited Warranty
- Includes: (1) Reciprocating Saw, (1) Belt Hook, (2) Blades
- Uncertainty K1 (Vibration): 2
- Nominal Maximum RPM: 910



SPECIFICATIONS

Voltage:	20 V
Battery Type:	Lithium-Ion
Strokes per Minute (SPM):	2800
Stroke Length:	5/8"

Model No.	Mfg. No.	Desc.	Price/Each
AUW234	DCS369B	Tool Only	225.00

M18 FUEL™ HACKZALL® RECIPROCATING SAW

- Cuts up to 50% faster than competitive one-handed reciprocating saws
- Up to 4x lower vibration for smooth cut starts and one-handed control
- Up to 3x longer tool life with REDLINK PLUS™ Intelligence that protects against overload and over heating, and a rubber seal and weep holes which provides added protection against water ingress and debris
- Compact and lightweight design allows for easier cutting in tight spaces or overhead applications
- Includes: General Purpose SAWZALL® Blade
- Compatible Batteries: 48-11-1815, 48-11-1820, 48-11-1828, 48-11-1840, 48-11-1850, 48-11-1860, 48-11-1890
- Compatible Chargers: 2710-20, 48-59-1812, 48-59-1808, 48-59-1807



SPECIFICATIONS

Voltage:	18 V
Battery Type:	Lithium-Ion
Strokes per Minute (SPM):	3000
Stroke Length:	7/8"

Model No.	Mfg. No.	Desc.	Price/Each
TY046	2719-20	Tool Only	253.00



M18 FUEL™ SAWZALL® RECIPROCATING SAW

- Wear resistant and anti-corrosion blade change
- Powerstate™ brushless motor provides increased cutting speed and power through the toughest applications
- Powerstate™ Brushless Motor: Increased cutting speed and power through the toughest applications
- Anti-corrosion blade clamp delivers prolonged blade clamp durability with less downtime due to corrosion
- Wear-resistant, lever actuated Quik-Lok™ blade clamp provides fast and easy blade changes
- Lever action Quik-Lok™ blade clamp provides fast and easy blade changes
- Metal reinforced battery connection provides improved durability and battery retention over life
- Redlink™ Plus Intelligence provides optimized performance and overload protection using total system communication between tool, battery and charger
- Adjustable shoe extends the life of the blade
- Built-in LED light illuminates the work surface while cutting
- Hang hook allows for convenient storage on the job
- Compatible with all M18™ batteries and M18™ chargers



SPECIFICATIONS

Voltage:	18 V
Battery Type:	Lithium-Ion
Strokes per Minute (SPM):	3000
Stroke Length:	1-1/4"
Tool Length:	17.1"

Model No.	Mfg. No.	Desc.	Price/Each
UAK056	2821-20	Tool Only	315.00



18 V SAWZALL® RECIPROCATING SAW

- Low vibration high speed functioning
- Lever action Quik-Lok™ blade clamp
- Patented gear-protecting clutch

SPECIFICATIONS

Voltage:	18 V
Battery Type:	Lithium-Ion
Strokes per Minute (SPM):	3200
Stroke Length:	1"
Tool Weight:	7.9 lbs.
Replacement Battery Model No.:	TLZ452

Model No.	Mfg. No.	Desc.	Price/Each
TLV560	2621-20	Tool Only	215.00



D-HANDLE JIG SAW

- The M18 Fuel D-Handle Jig Saw combines power, blade speed and precision, to deliver quality cuts in a wide variety of materials and applications
- Features a variable-speed two-finger trigger
- Toolless blade-change and bevel adjust
- Integrated LED light with on/off blower to Maximize cutline visibility
- Includes: (1) M18 FUEL™ D-Handle Jig Saw, (1) Anti-Splinter Guard, (1) Dust Collection Tube, (1) Dust Cover, (1) General Purpose Jigsaw Blade, (1) Hex Wrench, (1) Shoe Guard

SPECIFICATIONS

Voltage:	18 V
Battery Type:	Lithium-Ion
Strokes per Minute (SPM):	3500
Stroke Length:	1"



Model No.	Mfg. No.	Desc.	Price/Each
UAD742	2737-20	Tool Only	312.00

MAX XR® CORDLESS JIG SAW

- Brushless motor delivers efficient performance for longer runtime
- Compact size for easy grip and maximum control
- Bright LED light helps to illuminate dimly lit work surfaces
- Variable speed trigger and dial provide precise speed control
- All-metal, lever-action keyless blade change allows for quick and easy t-shank blade changes
- Integrated dust blower helps clear line of sight while cutting
- 4-position orbital action provides control of cut quality and speed
- All-metal, keyless shoe bevel with detents at 0°, 15°, 30°, and a positive stop at 45° for easy adjustment
- No-mar shoe cover to help protect work surface from scratches
- Accepts t-shank jig saw blades for optimal holding power and professional results
- Includes: Jig saw, Jig saw blade

SPECIFICATIONS

Voltage:	20 V
Battery Type:	Lithium-Ion
Strokes per Minute (SPM):	0-3200
Stroke Length:	1"



Model No.	Mfg. No.	Desc.	Price/Each
UAK905	DCS334B	Tool Only	305.00

M18™ COMPACT HEAT GUN

- High performance heating coil reaches operational temperature in 7 seconds (30% faster heat up than corded)
- Guarded nozzle provides increased protection for work surfaces
- Ladder hook allows users to easily hang the tool between applications
- Most compact electric heat gun at 6.4" long
- Compatible with all M18 RedLithium™ battery packs
- LED Light

SPECIFICATIONS

Voltage:	18 V
Amps:	5 A
Battery Type:	Lithium-Ion
Temperature:	875°F(468° C)
Temperature Setting:	Variable



Model No.	Mfg. No.	Desc.	Price/Each
TYY032	2688-20	Tool Only	190.00

MAX JIG SAW KIT

- All-metal, lever-action, keyless blade change allows for quick and easy blade changes
- All-metal, keyless shoe bevel with detents at 0°, 15°, 30°, and 45° provides versatility for easy bevel cutting
- 4-position orbital action provides control of cut quality and speed
- Adjustable dust blower keeps line of cut clear of chips
- Variable speed for versatility in a multitude of materials and applications
- Anti-slip comfort grip for increased comfort and control
- Accepts T-shank jig saw blades for optimal holding power and professional results
- Includes: 20 V Max jig saw, 20 V Max XR* Premium lithium-ion 4.0 Ah battery, Charger, Blade, Kit box



SPECIFICATIONS

Voltage:	20 V
Battery Type:	Lithium-Ion
Strokes per Minute (SPM):	0-3000
Stroke Length:	1"
Tool Weight:	6.8 lbs.



Model No.	Mfg. No.	Desc.	Price/Each
TLV838	DCS331B	Tool Only	269.00
TLV839	DCS331M1	Tool & Kit	449.00

CORDLESS 1" STEEL ROD CUTTER

- Ideal for cutting threaded rod and rebar
- Carbide tooth blade limits burring of threaded rod for fast and easy installation of nuts
- Automatic torque Drive Technology (ADT) feature adjusts the torque and speed according to the load condition, enabling rapid movement between high speed and high torque applications
- Brushless DC motor with high power to weight and size ratio
- Brushless DC motor generates less heat buildup and is ideal for prolonged use in manufacturing / production applications
- Battery protection system provides over-discharge, temperature and circuit protection for enhanced performance, battery cycle life and overall battery life
- Electric brake stops blade 3-5 seconds after trigger is released for increased operator safety
- LED charge level indicator displays approximate remaining battery power
- Ergonomic soft rubber grip design for vibration absorption and comfortable operation features re-contoured rear grip portion and ribbed grip for improved hold



Model No.	Mfg. No.	Desc.	Price/Each
UAV671	DSC2512K	Tool Only	2029.00

CORDLESS POWER TOOLS

MAX SAUSAGE PACK ADHESIVE GUN

- Variable speed trigger allows for increased control over the flow of your adhesive
- Anti-drip feature automatically retracts the plunging rod once trigger is released preventing excess adhesive from dripping out
- LED light assists users with visibility in low light situations
- Quick Connect Inter-changeable canister trays allows user to quickly change between canister sizes
- Battery sold separately

SPECIFICATIONS

Voltage: 20 V
Battery Type: Lithium-Ion
Cartridge Size: 300-600 ml
Maximum Speed: 21"/min

Model No. UAE523
Mfg. No. DCE580B
Price/Each \$399.00



M18™ CORDLESS 2-SPEED GREASE GUN KIT

- Offers users the ability to select between max pressure and max flow rate
- Delivers maximum pressure and unmatched versatility, offering an industry leading 10 000 PSI max operating pressure and a patent pending pre-set grease counter that allows service and maintenance professionals to dispense precise amounts of grease
- 2-speed design offers users the ability to select between max pressure and max flow rate
- Features include an on-board LED light, a lock-on/lock-off trigger, and a plunger rod with markings to gauge how much grease is left in the barrel
- Other unique features include an on-board LED light, a lock-on/lock-off trigger, and a plunger rod with markings to gauge how much grease is left in the barrel
- The tool's stand up design and shoulder strap capability offer user convenience, while limiting fatigue and the 48" flexible hose offers greater accessibility when greasing hard to reach fittings
- Powered by an M18™ Redlithium™ battery pack, this is the industry's only 18 V grease gun that's battery is compatible with a system of tools
- The kit includes the new multi-voltage charger, so you can charge all M12 and M18 lithium-ion batteries with one charger
- Air bleeder valve for quick priming
- Flow Rate: 10 oz/min
- Manufacturer's Warranty: 5 Year Limited
- Includes: M18™ Cordless 2-Speed Grease Gun, M18™ Compact Redlithium™ battery, M18™ & M12™ Multi-voltage charger, Carrying case

SPECIFICATIONS

Voltage: 18 V
Output Pressure: 10 000 PSI
Battery Type: Lithium-Ion
Cartridge Size: 14.5 oz.



TMB484

Model No.	Mfg. No.	Desc.	Price/Each
TMB482	2646-20	Tool Only	299.00
TMB483*	2646-21CT	Tool & Kit with 1 Battery	431.00
TMB484	2646-22CT	Tool & Kit with 2 Batteries	522.00

ADHESIVE GUN

- Variable speed trigger allows for increased control over the flow of your adhesive
- Anti-drip feature automatically retracts the plunging rod once trigger is released preventing excess adhesive from dripping out

SPECIFICATIONS

Voltage: 20 V
Battery Type: Lithium-Ion
Cartridge Size: 300 ml

Model No. UAE525
Mfg. No. DCE560B
Price/Each \$379.00



GREASE GUN KIT

- High operating pressure and flow rate powers through clogged fittings, quickly delivering grease and reducing job time
- Extended durability with a high-power, long-life motor and all-metal drivetrain
- Easy 3-way load system for Maximum versatility with cartridge, bulk, and manual loading
- Electronic shutdown and high-pressure LED indicator prevents grease spills and extends motor life
- Standard 30" hose improves reach
- Ergonomic handle with comfort grip helps reduce vibration, fatigue, and enhances user comfort
- Battery charger is wall or bench mount-able, and includes a USB port to charge and power other devices such as a smart phone
- Includes: Grease Gun, BC1121 Charger, BL2012 Battery, Case

SPECIFICATIONS

Voltage: 20 V
Battery Type: Lithium-Ion
Max. PSI: 6250
Flow Rate: 2.6 oz/min
Cartridge Capacity: 14 oz.

Model No.	Mfg. No.	Desc.	Price/Each
UA1464	LUB5130	Tool Only	381.00
UA1465	LUB5130-K12	Tool & Kit	584.00



20 V MAX LITHIUM ION GREASE GUN

- High-volume pump pushes up to 5.0 oz./min high-flow applications
- Up to 16 cartridges per charge
- Variable speed trigger offers precise control of the grease flow
- 42" extra-long and flexible hose designed for reaching hard to access grease fittings
- Includes: 20 V MAX XR premium Li-ion battery (4.0 Ah), fast charger, shoulder strap and kit box

SPECIFICATIONS

Voltage: 20 V
Output Pressure: 10 000 PSI
Battery Type: Lithium-Ion
Cartridge Size: 14 oz.



Model No.	Mfg. No.	Desc.	Price/Each
TYD765	DCG571B	Tool Only	315.00
TYD766	DCG571M1	Tool & Kit	479.00

M18 FUEL™ OSCILLATING MULTI-TOOL

- Powerstate™ brushless motor purposely built for the M18 Fuel™ Oscillating Multi-Tool combined with 10000 to 20000 OPM delivers fastest speed of cut
- Redlink Plus™ Intelligence: Ensures optimal performance and provides overload protection to prevent damage to the tool and battery during heavy applications while still maintaining compatibility across the entire M18™ System
- Variable speed dial allows user to adjust the speed of the application
- Auto-load feature allows the user to start slowly when making precise cuts, and automatically ramp up to the highest speed once under load, to provide unmatched productivity
- 180° span LED light for better visibility in low-light situations
- Aggressive 4.2° oscillating angle
- Tool-free blade change for faster accessory changes
- Compatible with all M18™ batteries
- With vibration dampening technology, this Multi-Tool provides more comfortable cutting with less fatigue over extended use
- Able to cut through nail-embedded wood, oak, grout, vinyl, copper, and PVC
- Includes: M18 Fuel™ Oscillating multi-tool, Open-Lok™ 1-3/8" HCS Wood blade, Multi-Tool Sanding Pad, 3-1/2" 60 Grit triangle sandpaper, 3-1/2" 80 Grit triangle sandpaper, 3-1/2" 120 Grit triangle sandpaper, 3-1/2" 240 Grit triangle sandpaper

SPECIFICATIONS

Voltage:	18 V
Battery Type:	Lithium-Ion
Oscillating Angle:	4.2°
RPM:	10 000
OPM:	10 000 - 20 000



Model No.	Mfg. No.	Desc.	Price/Each
UAK185	2836-20	Tool Only	326.00

XR® VARIABLE-SPEED RANDOM ORBITAL SANDER KIT

- Brushless motor provides runtime and efficiency to get the job done
- Variable speed control from 8000 – 12000 OPM to match the speed to the application
- Low profile height allows user to get close to work surface for precise sanding
- Replaceable 8-hole hook-and-loop sanding pad for quick, easy paper changing
- Dust port is designed to fit directly to the DWV010 or DWV012 dust collectors (sold separately)
- Dust-sealed switch to protect against dust ingestion for long switch life
- To attach dust port to other vacuum systems with 1-1/4" hoses, use DWV9000 Universal Quick Connector (sold separately)
- Texturized rubber overmold grip for comfortable sanding
- PSA replacement pad available as service part number N373679 (sold separately)
- One-handed locking dust bag
- Manufacturer's Warranty: 3-Year Limited Warranty
- Includes: (1) Random Orbital Sander, (1) Battery, (1) Bag
- Height: 12-4/5"
- Width: 13-4/7"



Model No.	Mfg. No.	Desc.	Price/Each
AUW236	DCW210B	Tool Only	209.00
AUW235	DCW210P1	Tool & Kit	389.00

M18™ ORBITAL SANDER

- Low vibration levels deliver enhanced comfort and user control to reduce fatigue
- Variable Speed Dial offers adjustment from 13K to 11K OPM for greater control of the material removal rate
- Orbit diameter of 1.6 mm delivers strong balance of removal rate and surface finish
- Included universal hose adapter provides compatibility with a wide range of vacuum sizes
- REDLINK Technology ensures maximum performance and protects from overloads, heating, and over-discharge
- Up to 95% dust collected for a cleaner work environment with less clean up time
- Two-step clamp system allows for quick and easy sandpaper changes
- Durable cotton dust bag delivers greater resistance against tears and leaks
- Part of the Milwaukee M18™ System, featuring over 200+ tools

SPECIFICATIONS

Voltage:	18 V
Sheet Size:	1/4 sheet
Orbits per minute:	11 000 - 13 000



Model No.	Mfg. No.	Desc.	Price/Each
UAV615	2649-20	Tool Only	178.00

M18™ COMPACT VACUUM

- The high performance motor creates good suction for the cleanup of drywall dust, wood/metal shavings, and other common jobsite debris
- Runs on M18™ Redlithium™ batteries (not included)
- Includes: (1) M18™ Compact Vacuum, (1) 4' Hose, (1) Crevice tool, (2) Extension, (1) HEPA filter, (1) Floor tool

SPECIFICATIONS

Voltage:	18 V
Battery Type:	Lithium-Ion
Tank Capacity:	0.3 gal.
CFM:	40
Inlet Diameter:	1-1/4"



Model No.	Mfg. No.	Desc.	Price/Each
UAF093	0882-20	Tool Only	192.00

M18™ WET/DRY VACUUM

- High performance motor creates powerful suction for both wet and dry applications
- Stackable design and organized on-board storage keeps all of the attachments inside the unit for convenient transport and storage
- Features a built-in blower port
- Includes: 6' Flexible nozzle, Crevice tool, Utility nozzle, HEPA filter
- Manufacturer's Warranty: 5 Year Limited

SPECIFICATIONS

Voltage:	18 V
Battery Type:	Lithium-Ion
Tank Capacity:	2 gal.
CFM:	45
Water Lift:	32"
Inlet Diameter:	1-1/4"



Model No.	Mfg. No.	Desc.	Price/Each
TMB616	0880-20	Tool Only	188.00

CORDLESS POWER TOOLS

ATOMIC CORDLESS & BRUSHLESS 2-TOOL COMBO KIT

- Impact driver allows you to complete a wide variety of applications with up to 1700 in-lbs of torque
- Impact driver is equipped with 3 LEDs for working in dark or confined spaces
- Easily change impact driver bits with quick release hex chuck
- Drill driver is best in class length at 5.88" to allow user increased accessibility in tight spaces
- The drill driver brushless motor provides 552 UWO of power
- Drill driver's 2-speed transmission has 15 clutch settings based on user application
- Includes: (1) DCD799 Drill Driver, (1) DCF809 Impact Driver, (1) DCB112 20V MAX Charger, (2) DCB203 2AH 20V MAX Batteries, (1) Carrying Bag
- Manufacturer's Warranty: Two-Year Warranty



SPECIFICATIONS

Voltage: 20 V
Battery Type: Lithium-Ion

Model No. UAV840
Mfg. No. DCK226D2
Price/Each \$419.00

MAX DRILL/DRIVER & ATOMIC IMPACT DRIVER 2-TOOL COMBO KIT

- Both tools are equipped with high-output brushless motors to help you tackle demanding projects
- The DCD800 Drill Driver is equipped with a 3 Position, pivoting LED for enhanced visibility in dimly lit work areas
- At less than 4 in. Length, the ATOMIC 20V MAX 1/4 in. Brushless Cordless 3-Speed Impact Driver can handle tight applications like narrow cabinetry or framing without the need for an additional tool
- Though the Impact Driver is lightweight and compact in size, it does not sacrifice performance with its brushless motor that delivers up to 1825 in/lbs. of torque and 3250 RPM for driving large-diameter screws
- Includes: 20V MAX XR Li-Ion 1/2" Drill Driver - DCD800, 20V MAX ATOMIC Li-Ion 1/4" 3-Speed Impact Driver - DCF850, (2) 20V MAX 2 Ah Compact Lithium-Ion Batteries - DCB203, 12V MAX - 20V MAX Lithium-Ion Battery Charger - DCB115, Kit Bag



SPECIFICATIONS

Voltage: 20 V
Battery Type: Lithium-Ion

Model No. AUW183
Mfg. No. DCK2051D2
Price/Each \$469.00

LXT® 2-TOOL BRUSHLESS MOTOR COMBO KIT

- Includes: (1) 1/2" Cordless hammer drill driver with brushless motor (DHP484Z), (1) 1/4" Cordless impact driver with brushless motor (DTD153Z), (2) 18 V (3.0 Ah) Lithium-ion batteries BL1830B (194205-3), (1) Standard charger (DC18SD), (1) 21" Tool bag



SPECIFICATIONS

Voltage: 18 V
Battery Type: Lithium-Ion

Model No. UAF035
Mfg. No. DLX21805
Price/Each \$415.00



LXT BL SUB-COMPACT 2-TOOL COMBO KIT

- Includes: 1/2" Sub-Compact Cordless Drill / Driver with Brushless Motor (DDF487ZB), 1/4" Sub-Compact Cordless Impact Driver with Brushless Motor (DTD157ZB), Two 18V (Compact) Li-ion Batteries BL1815N (196235-0), Standard Charger (DC18SD), Tool Bag (832069-4)



SPECIFICATIONS

Voltage: 18 V
Battery Type: Lithium-Ion

Model No. UAV611
Mfg. No. DLX2423BX3
Price/Each \$369.00



MAX XR® 2-TOOL COMBO KIT

- Includes: (1) Max XR® 3-Speed 1/2" hammerdrill, (1) Max XR® 1/4" Impact driver, (2) Max XR® High capacity 5.0 Ah batteries, charger, (2) Belt hooks, (1) 360° Side handle, (1) Kit box

SPECIFICATIONS

Voltage: 20 V
Battery Type: Lithium-Ion

Model No. UAE545
Mfg. No. DCK299P2
Price/Each \$739.00



M12 FUEL™ 2-TOOL COMBO KIT

- Most powerful subcompact hammer drill
- Fastest subcompact impact driver
- Most compact drill and impact driver for access in tight spaces
- Maximum workspace visibility through tri-LED work lights on the impact driver
- 1/2" All-metal chuck for maximum durability, grip and bit retention
- Mechanical clutch on drill for consistency in driving a wide range of fasteners
- Impact Driver includes 4-Mode drive control with dedicated self tapping screw mode
- More work per charge with the M12 Redlithium™ XC4.0 battery pack
- All-metal gear case for ultimate durability

SPECIFICATIONS

Voltage: 12 V
Battery Type: Lithium-Ion

Model No. UAV646
Mfg. No. 3497-22
Price/Each \$327.00



M18 FUEL™ 2-TOOL COMBO KIT

- Most powerful compact hammer drill in its class
- Powerstate™ Brushless motor delivers unmatched power
- Increase productivity with the fastest driving impact driver
- Powerstate™ Brushless Motor delivers the power to complete the widest range of applications of any hammer drill driver
- Powerstate™ Brushless motor delivers unmatched power for full range of capability to complete the widest variety of applications
- Increase productivity on the jobsite with the fastest driving speed of any impact driver without sacrificing power or control
- Drill is only 6.9" in length for access into tight spaces and reduced fatigue
- Ultimate trigger control by providing smooth acceleration for small fasteners to prevent stripping of screws or damaging of materials
- Fastest drilling and driving applications under load
- Auto-Stop feature to protect from over-rotation in a bind-up for enhanced safety, equipped with a dedicated autostop light on foot of tool to indicate a protection event
- Impact is only 4.47" for access in tight spaces
- 4-Mode Drive Control
- Mechanical clutch for consistency in driving a wide range of fasteners

SPECIFICATIONS

Voltage: 18 V
Battery Type: Lithium-Ion

Model No. UAV647
Mfg. No. 3697-22
Price/Each \$642.00



M18™ CORDLESS 6-TOOL COMBO KIT

- Includes: (1) M18™ Cordless 1/2" Hammer Drill/Driver (Bare Tool) (2602-20), (1) M18™ Sawzall® Reciprocating Saw (Bare Tool) (2620-20), (1) M18™ 6-1/2" Circular Saw (Bare Tool) (2630-20), (1) M18™ 1/4" Hex Compact Impact Driver (Bare Tool) (2650-20), (1) M18™ Cordless 4-1/2" Cut-off / Grinder (Bare Tool) (2680-20), (2) M18™ Redlithium™ XC Extended Capacity Battery (48-11-1828), (1) M18™ & M12™ Multi-Voltage Charger (48-59-1812), (1) M18™ Work Light (Bare Tool) (49-24-0171), (1) Contractor Bag

SPECIFICATIONS

Voltage: 18 V
Battery Type: Lithium-Ion

Model No. TMB508
Mfg. No. 2696-26
Price/Each \$980.00



4.0 AH LXT® 6-TOOL COMBO KIT

- Includes: 1/2" cordless hammer drill/driver, 1/4" cordless impact driver, 4-1/2" cordless angle grinder with brushless motor, cordless reciprocating saw, 6-1/2" cordless circular saw, cordless jigsaw, two 18v (4.0 ah) Li-Ion batteries, rapid charger, tool bag

SPECIFICATIONS

Voltage: 18 V
Battery Type: Lithium-Ion

Model No. TYX004
Mfg. No. DLX6079M
Price/Each \$1260.00



M18 FUEL™ 2-TOOL COMBO KIT

- Most powerful hammer drill featuring Powerstate™ Brushless Motor
- Only 6.9" in length making it the most compact drill in its class
- The quietest fastening solution featuring AutoStop™ Control
- Powerstate™ Brushless Motor delivers the power to complete the widest range of applications of any hammer drill driver
- Drill is only 6.9" in length for access into tight spaces and reduced fatigue
- Auto-Stop feature to protect from over-rotation in a bind-up for enhanced safety, equipped with a dedicated autostop light on foot of tool to indicate a protection event
- Hammer Drill Mode for fast drilling into brick, block or concrete
- Includes: (1) M18 Fuel 1/2" Hammer Drill (2904-20), (1) M18 Fuel SURGE 1/4" Hydraulic Driver (2760-20), (2) M18 REDLITHIUM XC5.0 Battery Packs, (1) M18 & M12 Multi-Voltage Charger, (1) Side Handle, (2) Belt Clip, (1) Carrying Case

SPECIFICATIONS

Voltage: 18 V
Battery Type: Lithium-Ion

Model No. UAV648
Mfg. No. 3699-22
Price/Each \$600.00



MAX XR® BRUSHLESS 6-TOOL COMBO KIT

- Hammer drill and impact driver have a brushless motor for longer runtime and efficiency
- Circular saw uses a 7-1/4" blade to provide 2-9/16" cutting capacity at 90°
- Impact driver has 3 speed settings for versatility with precision drive for added control
- Hammer drill features a heavy-duty 1/2" ratcheting nitro-carburized metal chuck with carbide inserts for superior bit gripping strength
- Reciprocating saw has a variable-speed trigger with 0-2900 SPM
- Grinder has an 8000 RPM motor that provides high power for cutting and grinding applications
- Includes: 20 V Max hammer drill driver, 20 V Max impact driver, 20 V Max circular saw, 20 V Max LED work light, 20 V Max grinder, 20 V Max reciprocating saw, Charger, Tool bag

SPECIFICATIONS

Voltage: 20 V
Battery Type: Lithium-Ion

Model No. UAI785
Mfg. No. DCK695P2
Price/Each \$1469.00



CORDLESS POWER TOOLS



M18 FUEL™ 7-TOOL COMBO KIT

- This power tool kit features seven M18 Fuel™ 18-Volt lithium-ion brushless cordless tools, including a 1/2 in. hammer drill, 1/4 in. impact driver, 1/2 in. mid-torque impact wrench, SAWZALL® reciprocating saw, 6-1/2 in. circular saw, 4-1/2 in. / 5 in. grinder and LED work light. M18 Fuel™ is fully compatible with the MILWAUKEE® M18™ Cordless system, featuring over 250 Plus tools
- M18 Fuel™ features the most advanced cordless technology in the industry with a Powerstate Brushless Motor, Redlink™ Plus Intelligence, and Redlit Battery Technology, for longer motor life, longer run time, and more power
- Includes: (1) M18 Fuel™ 1/2" Hammer Drill/Driver(2904-20), (1) M18 Fuel™ 1/4" Hex Impact Driver(2953-20), (1) M18 Fuel™ SAWZALL Recip Saw(28220), (1) M18 Fuel™ 6-1/2" Circular Saw (Tool Only)(2730-20), (1) M18 Fuel™ 4-1/2" / 5" Braking Grinder Paddle Switch, No-Lock(2880-20), (1) M18 Fuel 1/2" Mid-Torque Impact Wrench with Friction Ring(2962-20), (1) M18™ W Light(2735-20), (2) M18™ Redlithium™ XC5.0 Extended Capacity Battery 11-1850), (1) M18™ & M12™ Multi-Voltage Charger(48-59-1812), (1) Bag



SPECIFICATIONS

Voltage: 18 V
Battery Type: Lithium-Ion

Model No. AUW181
Mfg. No. 3697-27
Price/Each \$1744.00



M18 FUEL™ 5-TOOL COMBO KIT

- Hammer drill provides access into tight spaces and reduces fatigue
- The hammer drill auto-stop feature prevents over-rotation in a bindup for enhanced safety
- An auto-stop light on the foot of the hammer drill indicates an auto-stop event
- Impact driver offers tri-LED lighting for maximum workspace visibility
- Ultimate trigger control provides smooth acceleration for small fasteners to prevent stripping of screws or damaging of materials
- Recip saw removes more material with each stroke
- Circular saw features a PowerState™ brushless motor, providing up to 3 times longer tool life
- M18 cordless LED work light has more than 600 times the life of conventional incandescent bulbs and runs up to 4 times as long
- RedLithium™ battery packs deliver more work-per-charge and more work over the life of the pack than competitors
- RedLink Plus™ intelligence ensures optimal performance and provides overload protection to prevent damage to the tool and battery during heavy applications while still maintaining compatibility across the entire M18 system
- Includes: (1) M18 Fuel™ 1/2" Hammer Drill/Driver, (1) M18 Fuel™ 1/4" Hex Impact Driver, (1) M18 Fuel™ Sawzall® Recip Saw, (1) M18 Fuel™ 6-1/2" Circular Saw (Tool Only), (1) M18™ Work Light, (2) M18™ RedLithium™ XC5.0 Extended Capacity Battery Pack, (1) M18™ & M12™ Multi-Voltage Charger, (1) Bag, (1) Side Handle, (2) Belt Clip, (1) Circular Saw Blade, (1) Blade Wrench

SPECIFICATIONS

Voltage: 18 V
Battery Type: Lithium-Ion

Model No. UAV796
Mfg. No. 3697-25
Price/Each \$1253.00



M18 FUEL™ COMPACT QUIET COMPRESSOR

- The quietest cordless compressor available at only 68 dB(A)
- Reduced noise level allows for the compressor to be used as close to the task as necessary, reducing the need for extra hoses and yelling to communicate
- Powered by M18™ Redlithium™ batteries that work on over 200+ Tools, the compressor can shoot up to 1600 brad nails per charge to get through a full day of work
- Ergonomic handle that allow it to be carried vertically
- Compact for easy carrying & less fatigue while transporting
- Compatible with all Milwaukee® M18™ Redlithium™ batteries making it easy to swap packs
- CFM: 1.2 @ 90 PSI
- Voltage/Phase: 18/1
- Tank Capacity: 2 Gal. (2.4 US Gal)
- Max. PSI: 135
- Sound Level (dBA): 68
- Pump Type: Oil Free
- Length: 16.25"
- Height: 10.62"
- Width: 18.62"
- Weight: 31.2 lbs.
- Tool Only

Model No. UAK180
Mfg. No. 2840-20
Price/Each \$523.00



M12™ SPOTLIGHT

- Impact-resistant lens
- Lamp Type: LED
- Lumens (High): 750
- Run Time Hrs. (High): 4
- Body Material: Plastic
- Battery Type: Rechargeable
- Body Colour: Red
- Batteries Not Included
- High Mode: 750 Lumens/4hrs.
- Low Mode: 400 Lumens/8hrs.
- Voltage: 12 V
- Strobe Mode: 800 Lumens/8 hrs

Model No. UAE212
Mfg. No. 2353-20
Price/Each \$135.00



Milwaukee

18 V M18™ LED WORK LIGHTS

- Sealed, aluminum head – Impact and weather resistant
- 160 lumen LED – Bright, white, smooth beam
- Integrated hook – Hands-free use
- 135° rotating head
- Runs on M18™ battery (not included)
- Tool length: 8 1/2"
- Tool weight: 1 lbs.

Model No. TLV686
Mfg. No. 2735-20
Price/Each \$105.00



Milwaukee

LXT® LANTERN & FLASHLIGHT

- Three LED lighting modes: 360° lantern, 180° lantern or flashlight
- Metal hang hook swivels 360° and folds away for added convenience
- Rubberized soft grip provides increased comfort on the job
- Battery and charger sold separately
- Lumens (High): 620
- Lumens (Low): 90
- Run Time Hrs. (High): 11
- Run Time Hrs. (Low): 25
- Body Material: Plastic
- Battery Type: Rechargeable
- Body Colour: Blue
- Battery: 18V LXT® Lithium-Ion (Not Included)
- Height: 14-3/8"
- Weight with Battery: 2.1 lbs.
- Manufacturer's Warranty: 3 years

Model No. UAE996
Mfg. No. DML806
Price/Each \$139.00



Makita

JOBSITE BLUETOOTH RADIO

- Powered by 20 V Max battery, FlexVolt® 20 V/60 V Max battery, or AC power cord
- Features Aux & 2.1 AMP USB charging port
- Features two AC power outlets
- Bluetooth connectivity available up to 100 feet
- Batteries not included
- Voltage: 60 V
- Battery Type: Lithium-Ion

Model No. UAE024
Mfg. No. DCR025
Price/Each \$349.00

DEWALT



M18™/M12™ WIRELESS JOBSITE SPEAKER

- Industry's loudest, clearest sound system
- Stream high definition music wirelessly with Bluetooth® from over 100'
- 2 passive radiators maximize clarity and volume of bass
- 2 high definition mid-woofers maximize clarity at loudest volume
- 2 high range tweeters drive greater range of treble
- Includes: (1) M18™/M12™ wireless jobsite speaker, (1) AC adapter
- Voltage: 18 V
- Battery Type: Lithium-Ion
- Tool Warranty: 1 years

Model No. TYX829
Mfg. No. 2891-20
Price/Each \$262.00

Milwaukee



HEAVY-DUTY FLASHLIGHTS

- High quality construction
- 4-position pivoting head
- Uses standard pod style Makita battery (not included)
- Lightweight design



Makita

Model No.	Mfg. No.	Volts	Price/Each
TJ128	ML180	18	109.00
TJ129	ML140	14.4	93.50

M18™ LED FLOOD LIGHT

- Up to 30% brighter than corded 250 W halogen lights
- Innovative roll cage design
- Versatile hanger provides hands-free use in a variety of applications
- Up to 8 hours of run-time
- Runs on M18™ batteries (not included)
- Dimensions: 6-1/4" L x 6-1/4" W x 6-1/4" H
- Lamp type: LED
- Lumens: 1500
- Wattage: 8 W
- Lamp life: 50000 hrs.
- Housing material: Rubber
- Colour: Red

Model No. TYD830
Mfg. No. 2361-20
Price/Each \$179.00



Milwaukee

M18™ JOBSITE RADIO & CHARGER

- Built-in charger for quick and convenient charging of all M18™ batteries
- Exclusive digital Bluetooth® receiver allows for wireless audio streaming from over 100' away
- USB power port allows for 50% faster device charging, plugged in or on the go
- Premium speakers and 40-watt amplifier
- Customizable equalizer and 10 preset stations
- Voltage: 18 V
- Charging Time: 60 min.
- Battery Type: Lithium-Ion
- Modes: FM/AM, AUX, Bluetooth
- USB Port: 2.1 amps
- Customizable Equalizer: Yes
- Tool Warranty: 1 year

Model No. TYD895
Mfg. No. 2792-20
Price/Each \$360.00

Milwaukee



CORDLESS POWER TOOLS

BATTERIES



Model No.	Mfg. No.	Description	Price /Each
MILWAUKEE			
TLV689	48-11-1820	18 V M18™ Redlithium™ Battery (2.0 Ah)	140.00
TLV690	48-11-1822	18 V M18™ Redlithium™ Batteries 2-Pack (2.0 Ah)	279.00
TLZ452	48-11-1828	18 V High-Capacity Battery (3.0 Ah)	171.00
UAE101	48-11-1835	M18™ Redlithium™ High Output™ CP3.0 Battery (3.0 Ah)	171.00
UAE102	48-11-1837	M18™ Redlithium™ High Output™ CP3.0 Battery 2-Pack (3.0 Ah)	279.00
TLV635	48-11-1840	18 V M18™ Redlithium™ Battery (4.0 Ah)	193.00
TYL255	48-11-1850	18 V M18™ Redlithium™ XC5.0 Extended Capacity Battery (5.0 Ah)	223.00
TY0323	48-11-1852	18 V M18™ Redlithium™ Battery 2-Pack (5.0 Ah)	381.00
UAD788	48-11-1851	18 V M18™ Redlithium™ Battery 10-Pack (5.0 Ah)	1667.00
UAJ553	48-11-1862	18 V Redlithium™ High Output™ XC6.0 Battery 2-Pack	460.00
UAF958	48-11-1865	18 V M18™ Redlithium™ High Output™ 6.0 Battery (6.0 Ah)	277.00
UAE104	48-11-1880	18 V M18™ Redlithium™ High Output™ XC8.0 Battery (8.0 Ah)	316.00
TYY303	48-11-1812	18 V M18™ Redlithium™ High Output™ HD12.0 Battery (12.0 Ah)	423.00
TLV691	48-11-2001	4 V M4™ Redlithium™ Battery (2.0 Ah)	55.90
TLZ368	48-11-2401	12 V Battery (1.5 Ah)	73.00
TLV692	48-11-2411	12 V M12™ Redlithium™ Batteries 2-Pack (1.5 Ah)	121.00
TLV694	48-11-2420	12 V M12™ Redlithium™ 2.0 Battery (2.0 Ah)	89.00
TLV693	48-11-2412	12 V M12™ Redlithium™ Batteries 2-Pack (2.0 Ah)	186.00
UAV633	48-11-2425	12 V M12™ Redlithium™ Battery (2.5 Ah)	120.00
TLV039	48-11-2402	12 V M12™ Redlithium™ High-Capacity Battery (3.0 Ah)	111.00
UAE105	48-11-2430	12 V M12™ Redlithium™ 3.0 Compact Battery (3.0 Ah)	101.00
TLV695	48-11-2440	12 V M12™ Redlithium™ 4.0 Battery (4.0 Ah)	144.00
UAV634	48-11-2450	12 V M12™ Redlithium™ High Output™ Battery XC5.0 (5 Ah)	175.00
UAK189	48-11-2460	12 V M12™ Redlithium™ Battery (6 Ah)	175.00
UAI578	MXFXC406	72 V MX Fuel™ Redlithium™ XC406 Battery (6.0 Ah)	846.00
MAKITA			
TYL256	196235-0	18 V Lithium-Ion Battery (1.5 Ah)	98.50
TLZ879	194230-4	18 V Lithium-Ion 3.0 Ah BL1830	235.00
TYL079	196401-9	18 V Lithium-Ion Battery (4.0 Ah)	165.00
NJW954	196406-9	18 V Lithium-Ion Battery (4.0 Ah) 2-Pack	279.00
TY0642	196675-2	18 V Carded Casing Lithium-Ion Battery (5.0 Ah)	165.00
TY0643	196681-7	18 V Carded Casing Lithium-Ion Battery (5.0 Ah) 2-Pack	305.00
TLV226	195332-9	12 V Lithium-Ion Battery (1.3 Ah)	79.90
TYX005	197414-3	12 V Max CXT Battery (2.0 Ah)	69.50
TYX006	197416-9	12 V Max CXT Battery (4.0 Ah)	105.00
TNB485	198001-1	7.2 V Lithium-Ion Battery (1.0 Ah)	70.90

CHARGERS



Model No.	Mfg. No.	Description	Price /Each
MILWAUKEE			
TYO326	48-59-1204	M12™ Four Bay Sequential Charger	129.00
UAJ162	48-59-1802	M18™ Dual Bay Simultaneous Rapid Charger	200.00
TMB524	48-59-1806	M18™ Six Pack Sequential Charger	169.00
TYO327	48-59-1807	M18™ & M12™ Rapid Charge Station	279.00
UAD746	48-59-1808	M18™ & M12™ Rapid Charger	115.00
TLY296	48-59-1812	18 V Battery Charger	83.90
TYO329	48-59-1850	18V M18™ Redlithium™ XC5.0 Starter Kit Battery & Charger (5.0 Ah)	278.00
UAE107	48-59-1880	18V M18™ Redlithium™ High Output™ XC8.0 Battery & Charger (8.0 Ah)	418.00
TMB526	48-59-2001	M4™ Charger	59.50
TLY297	48-59-2401	12 V Battery Charger	67.50
UAI579	MXFC	MX Fuel™ Battery Charger	339.00
MAKITA			
TYY290	DC10SB	12 V Max* CXT Series Rapid Battery Charger	119.00
TLZ901	DC18RC	18 V Battery Charger	135.00
TYX076	DC18RD	18 V Li-On Dual Port Rapid Charger	205.00
UAE961	DC18RE	12 V/18 V Dual-Port Rapid Battery Charger	165.00



Model No.	Mfg. No.	Description	Price /Each
DEWALT			
TLV778	DCB201	20 V Max* Compact Battery (1.5 Ah)	125.00
TLV656	DCB203	20 V Max* Compact XR Battery (2.0 Ah)	139.00
TLV777	DCB203-2	20 V Max* Compact XR Battery 2-Pack (2.0 Ah)	215.00
UAF151	DCB230	20 V Max* Compact Battery (3.0 Ah)	169.00
UAJ166	DCB240	20 V Max* Compact Battery (4.0 Ah)	205.00
UAJ167	DCB240-2	20 V Max* Compact Battery 2-Pack (4.0 Ah)	315.00
TYK683	DCB205	20 V Max* Premium XR Battery (5.0 Ah)	225.00
TYL315	DCB205-2	20 V Max* Premium XR Battery 2-Pack (5.0 Ah)	305.00
UAI788	DCB206	20 V Max* Premium XR Battery (6.0 Ah)	249.00
TYW912	DCB606	20 V/60 V FlexVolt™ Battery (6.0 Ah)	259.00
TYW913	DCB606-2	20 V/60 V FlexVolt™ Battery 2-Pack (6.0 Ah)	375.00
TYX779	DCB609-2	20 V/60 V FlexVolt™ Battery (9.0 Ah)	485.00
UAI739	DCB612	20 V/60 V FlexVolt™ Battery (12.0 Ah)	399.00
UAF550	DCB124	12 V Max* Battery (3.0 Ah)	125.00
UAF551	DCB124-2	12 V Max* Battery 2-Pack (3.0 Ah)	165.00
INGERSOLL RAND			
UAI485	BL1203	12 V IQV12 Series Battery (2.0 Ah)	132.00
UAI486	BL2012	20 V IQV20 Series Battery (2.5 Ah)	205.00
UAE925	BL2022	20 V IQV20 High Capacity Battery (5.0 Ah)	299.00



Model No.	Mfg. No.	Description	Price /Each
DEWALT			
TYL312	DCB102	12 V/20 V Max Jobsite Charging Station	179.00
UAE544	DCB104	20 V Multiport Simultaneous Fast Charger	345.00
UAE542	DCB118	20 V Fan Cooled Fast Charger	155.00
TYW902	DCB1800B	1800 Watt Portable Power Station And Parallel Battery Charger	729.00
INGERSOLL RAND			
UAE927	BC1121	IQV Universal Tool Battery Charger	194.00

ANGLE GRINDERS

- Compact, lightweight design
- 750 MWO motor: Powerful for daily applications
- Debris baffles: Protect internal components by deflecting damaging debris out of the airflow at the intake vents
- Multi-port exhaust: Reduces motor burn-up by efficiently venting hot air out of the grinder
- Tool free, burst resistant guard: The only grinder in its class with a tool free guard
- Compatible with multiple grinder guards and flanges
- Includes: Type 27 guard, side handle and spanner wrench

Model No. TLV064
Mfg. No. 6130-33
Price/Each \$105.00

SPECIFICATIONS

Wheel Diameter: 4 1/2"
Voltage: 120 V
Amperage: 7.0
No Load RPM: 11 000
Spindle Size: 5/8"-11
Tool Weight: 3.5 lbs.



ANGLE GRINDERS W/TRIGGER GRIP

- Powerful 13 Amp, 9000 RPM motor: Provides maximum performance and durability
- Overload protection: Maximizes motor life
- Electronic clutch: Extends tool life and prevents bind-up
- Tool-free accessory change: Easily change all accessories without a wrench
- Tool-free adjustable guard: Provides quick guard installations and adjustments
- Anti-vibration side handle: Reduces vibration, increasing user comfort during extended use
- Trigger grip handle: Provides better control, reach and leverage
- Includes: Lock-on, type 27 guard, side handle, spanner wrench and flanges

Model No. TLV198
Mfg. No. 6124-30
Price/Each \$289.00

SPECIFICATIONS

Wheel Diameter: 5"
Voltage: 120 V
Amperage: 13.0
No Load RPM: 9000
Spindle Size: 5/8"
Tool Weight: 5.7 lbs.



4-1/2" ANGLE GRINDERS

- Dust Ejection System™ provides durability by ejecting damaging dust and debris particles
- Large spiral bevel gear provides long transmission life
- One-Touch™ Guard allows for 360° rotation of the guard with a single action
- Paddle switch with safety lock-off prevents accidental start up
- Includes: 2-position side handle and One-Touch™ Guard

Model No. TYL343
Mfg. No. DWE402
Price/Each \$149.00

SPECIFICATIONS

Wheel Diameter: 4 1/2"
Voltage: 120 V
Amperage: 11.0
No Load RPM: 11 000
Spindle Size: 5/8"-11
Tool Weight: 4.6 lbs.



ANGLE GRINDERS W/CASE

- Labyrinth construction seals motor and bearings from contamination
- Thumb switch conveniently located for operator comfort
- Ergonomic soft grip for vibration absorption and comfortable operation
- Slim housing design for easy handling and maneuverability
- Includes: Grinding wheel, lock nut, lock nut wrench, inner flange, wheel cover assembly and plastic carrying case

Model No. TLV165
Mfg. No. GA4530K
Price/Each \$129.00

SPECIFICATIONS

Wheel Diameter: 4 1/2"
Voltage: 120 V
Amperage: 6.0
No Load RPM: 11 000
Spindle Size: 5/8"
Tool Weight: 4.0 lbs.



HEAVY-DUTY ANGLE GRINDERS

- High power-to-weight ratio for greater efficiency and reduced user fatigue
- External brush doors for easy servicing
- Sealed ball and roller bearings for extended motor life
- Includes: Grinding wheel, wrench, keyless adjustable guard and two position side handle

Model No. VE980
Mfg. No. DW831
Price/Each \$165.00

SPECIFICATIONS

Wheel Diameter: 5"
Voltage: 120 V
Amperage: 12.0
No Load RPM: 10 000
Spindle Size: 5/8"
Tool Weight: 7.4 lbs.



ANGLE GRINDERS

- Powerful 7.5 Amp, 10 000 RPM motor: Provides maximum performance and durability
- Overload protection: Maximizes motor life
- Electronic clutch: Extends tool life and prevents bind-up
- Tool-free accessory change: Easily change all accessories without a wrench
- Tool-free adjustable guard: Provides quick guard installations and adjustments
- Includes: 4 1/2" grinding wheel, wheel guard, lock nut, lock nut wrench, side handle and inner flange

Model No. TGZ314
Mfg. No. 9557NB
Price/Each \$155.00

SPECIFICATIONS

Wheel Diameter: 4 1/2"
Voltage: 120 V
Amperage: 7.5
No Load RPM: 10 000
Spindle Size: 5/8"
Tool Weight: 4.5 lbs.



MINI-GRINDER™

- Safety clutch eliminates backlash
- Exclusive Quick feature for tool-free wheel change
- Includes: Side handle

Model No. TD920
Mfg. No. 30-A-161
Price/Each \$335.00

SPECIFICATIONS

Wheel Diameter: 4 1/2"
Voltage: 120 V
Amperage: 8.0
No Load RPM: 10 000
Spindle Size: 5/8"
Tool Weight: 4.0 lbs.



CORDED POWER TOOLS



ANGLE GRINDERS

- Slide switch with Lock-On
- Powerful 13 Amp, 11 000 RPM motor
- Electronic clutch: Extends tool life and prevents bind-up
- Tool-free accessory change: Easily change all accessories without a wrench
- Tool-free adjustable guard: Provides quick guard installations and adjustments
- Anti-vibration side handle: Reduces vibration, increasing user comfort during extended use
- Soft start: Allows maximum control at start-up
- Includes: Type 27 guard, side handle, spanner wrench and flanges

Model No. TLV735
Mfg. No. 6117-33
Price/Each \$255.00

SPECIFICATIONS

Wheel Diameter: 5"
Voltage: 120 V
Amperage: 13.0
No Load RPM: 11 000
Spindle Size: 5/8"
Tool Weight: 5.7 lbs.

Milwaukee



ANGLE GRINDERS

- Labyrinth construction seals motor and bearings from contamination
- New motor with added resistance to heat and overload
- Motor winding protection to protect the wires from abrasion
- Includes: Side handle and 5" grinding wheel

Model No. TLZ330
Mfg. No. GA5010
Price/Each \$215.00

SPECIFICATIONS

Wheel Diameter: 5"
Voltage: 120 V
Amperage: 10.5
No Load RPM: 11 000
Spindle Size: 5/8"
Tool Weight: 7.9 lbs.

Makita



SUPER-5™ GRINDER

- Safety clutch eliminates backlash
- Dustguard™ protects motor from abrasive particles
- Includes: Side handle

Model No. TD921
Mfg. No. 30-A-150
Price/Each \$385.00

SPECIFICATIONS

Wheel Diameter: 5"
Voltage: 120 V
Amperage: 10.5
No Load RPM: 11 000
Spindle Size: 5/8"
Tool Weight: 4.2 lbs.

WALTER
 Surface Technologies



HEAVY-DUTY MEDIUM ANGLE GRINDERS

- High power-to-weight ratio for greater efficiency and reduced user fatigue
- External brush doors for easy servicing
- Sealed ball and roller bearing for extended motor life
- Includes: Grinding wheel and 2-position side handle

Model No. VE383
Mfg. No. DW840
Price/Each \$249.00

SPECIFICATIONS

Wheel Diameter: 7"
Voltage: 120 V
Amperage: 13.0
No Load RPM: 8000
Spindle Size: 5/8"
Tool Weight: 8.0 lbs.



DEWALT

4-1/2" SMALL ANGLE GRINDER

- Electronic clutch extends tool life and prevents bind-up
- Easily change all accessories without a wrench
- Provides quick guard installations and adjustments
- Includes: (1) contractor bag, (1) flange, (1) grinding wheel, (1) side handle, (1) spanner wrench, (1) type 27 guard

Model No. TYX084
Mfg. No. 6141-31
Price/Each \$179.00

SPECIFICATIONS

Wheel Diameter: 4 1/2"
Voltage: 120 V
Amperage: 11.0
No Load RPM: 11 000
Spindle Size: 5/8"-11
Tool Weight: 8.16 lbs.

Milwaukee



ANGLE GRINDERS W/TRIGGER GRIP

- Trigger grip handle provides better control, reach and leverage
- Debris baffles protect internal components by deflecting damaging debris out of the airflow at the intake vents
- External brush doors reduces service time by providing easy access to brushes
- Includes: Side handle, spanner wrench and type 27 guard

Model No. TLZ810
Mfg. No. 6121-31A
Price/Each \$209.00

SPECIFICATIONS

Wheel Diameter: 5"
Voltage: 120 V AC/DC
Amperage: 11.0
No Load RPM: 11 000
Spindle Size: 5/8"
Tool Weight: 5.6 lbs.

Milwaukee



ANGLE GRINDERS W/LOCK-ON

- Powerful 13 Amp, 11 000 RPM motor: Provides maximum performance and durability
- Overload protection: Maximizes motor life
- Electronic clutch: Extends tool life and prevents bind-up
- Tool-free accessory change: Easily change all accessories without a wrench
- Tool-free adjustable guard: Provides quick guard installations and adjustments
- Anti-vibration side handle: Reduces vibration, increasing user comfort during extended use
- Soft start: Allows maximum control at start-up
- Includes: Type 27 guard, side handle, spanner wrench and flanges

Model No. TLV197
Mfg. No. 6117-30
Price/Each \$255.00

SPECIFICATIONS

Wheel Diameter: 5"
Voltage: 120 V
Amperage: 13.0
No Load RPM: 11 000
Spindle Size: 5/8"
Tool Weight: 5.7 lbs.



Milwaukee

ANGLE GRINDERS W/LOCK-ON

- Powerful 13 Amp, 9000 RPM motor: Provides maximum performance and durability
- Overload protection: Maximizes motor life
- Electronic clutch: Extends tool life and prevents bind-up
- Constant Power Technology™: Maintains constant speed under load
- Tool-free accessory change: Easily change all accessories without a wrench
- Tool-free adjustable guard: Provides quick guard installations and adjustments
- Anti-vibration side handle: Reduces vibration, increasing user comfort during extended use
- Soft start: Allows maximum control at start-up
- Includes: Lock-on, type 1 guard, side handle and spanner

Model No. TLV199
Mfg. No. 6161-30
Price/Each \$275.00

SPECIFICATIONS

Wheel Diameter: 6"
Voltage: 120 V
Amperage: 12.0
No Load RPM: 9000
Spindle Size: 5/8"
Tool Weight: 6.3 lbs.



6" ANGLE GRINDER

- Trigger Switch with No Lock-On Button
- SJS (Super Joint System) prevents kickback during wheel lock
- Electric Brake for increased operator safety
- Rotatable gear housing can be positioned at every 90° for optimal positioning
- Removable side handle can be mounted on left or right side of tool
- Ergonomic soft rubber grip design for vibration absorption and comfortable operation
- Includes: Grip, Lock Nut Wrench, Tool-less Wheel Cover, 6" Depressed Centre Wheel, Inner Flange, Lock Nut, Dust Cover Attachment

Model No. TNB127
Mfg. No. GA6020
Price/Each \$229.00

SPECIFICATIONS

Wheel Diameter: 6"
Voltage: 120 V
Amperage: 10.5
No Load RPM: 10 000
Spindle Size: 5/8" - 11 UNC
Tool Weight: 6.6 lbs.



LARGE ANGLE GRINDERS TRIGGER GRIP W/LOCK-ON OR NON LOCK-ON

- Debris baffles protect internal components by deflecting damaging debris out of the airflow at the intake vents
- External brush doors reduce service time by providing easy access to brushes
- Soft-grip main handle provides better control and comfort
- Includes: Side handle, 7" and 9" type 27 guard and spanner wrench

Model No. TLZ819
Mfg. No. 6088-30
Price/Each \$319.00

SPECIFICATIONS

Wheel Diameter: 7" to 9"
Voltage: 120 V
Amperage: 15.0
No Load RPM: 6000
Spindle Size: 5/8"
Tool Weight: 13.7 lbs.
Trigger, Non Lock-On
Model No.: TLZ820



ANGLE GRINDERS

- Ergonomic soft rubber grip for vibration absorption and comfortable operation
- Removable side handle can be mounted on left or right side of tool
- Rotatable gear housing can be positioned at every 90°
- Rear handle swivels 180°
- Includes: Vibration proof grip, dust cover attachment set, lock nut wrench, toolless wheel cover assembly, inner flange and lock nut

Model No. TLV144
Mfg. No. GA7031
Price/Each \$329.00

SPECIFICATIONS

Wheel Diameter: 7"
Voltage: 120 V
Amperage: 15.0
No Load RPM: 8500
Spindle Size: 5/8"
Tool Weight: 13.5 lbs.



XTRACT™ ELECTRIC RANDOM ORBITAL SANDER

- Lightweight, comfortable design
- Soft-touch grip with moulded-in grip features
- Powerful 350 W electric motor
- Stays cool and comfortable while running
- HMI and illuminated power indicator
- Easily connects to the 3M® Xtract™ Portable Dust Extractor or existing central vacuum system
- The rear threaded attachment enables easy, secure attachment and detachment of a 1" (25.4 mm) external threaded vacuum hose (sold separately) to effectively eliminate dust from the workpiece and surrounding space
- When used with 3M Xtract™ Net Discs and dust extraction, the system extracts up to 97% of the dust created during sanding
- Voltage: 110 V
- Speed: 4000 - 10000 RPM
- Plug Type: B
- Vacuum Type: Central Vacuum



XTRACT™ PORTABLE DUST EXTRACTOR

- Powerful industrial vacuum unit connects to 3M Xtract™ Random Orbital Sanders to remove dust from the work surface
- Automatic on/off compatibility with pneumatic and electric sanders
- Compact, sturdy design helps stand up to harsh industrial conditions
- Automatic filter clean without flow stoppage
- Quiet 69 dB(A) operation
- Front panel offers convenient access to controls and connections
- Optimal vacuum: 25.5 kPa (102 inches of H₂O) at the fan
- Dual HEPA Filters
- Adjustable airflow
- Suction Capacity: 157 CFM
- Voltage: 110 V

Model No. UAV674
Mfg. No. AB64256
Price/Each \$1479.85



Model No.	Mfg No.	Sand Paper Size"	Orbit Diameter"	Price /Each
UAV676	AB88758	5	3/16	733.51
UAV679	AB88760	6	3/16	733.51
UAV677	AB88762	5	3/32	733.51
UAV678	AB88764	6	3/32	733.51



HEAVY-DUTY BIG 6™ GRINDER

- Built-in temperature sensor protects motor from burnout
- Built-in safety feature prevents accidentally restarting after a power failure
- Soft start feature reduces peak power loads and torque at start-up
- Includes: Side handle, flange, quick nut and wheel guard

Model No. TD923
Mfg. No. 30A260
Price/Each \$509.00

SPECIFICATIONS

Wheel Diameter: 6"
Voltage: 120 V
Amperage: 14.5
No Load RPM: 9600
Spindle Size: 5/8" - 11
Tool Weight: 5.9 lbs.



MAXI GRINDER™ 7"

- Carbon brush service door
- Lower profile gear housing
- More powerful motor, improved DUSTGUARD protection
- New ergonomic design with rotating back handle
- Tool-free adjustable guard and spindle lock

Model No. TD924
Mfg. No. 30A170
Price/Each \$509.00

SPECIFICATIONS

Wheel Diameter: 7"
Voltage: 120 V
Amperage: 15.0
No Load RPM: 8500
Spindle Size: 5/8" - 11
Tool Weight: 12.8 lbs.



MAXI GRINDER™ 9"

- Carbon brush service door
- Lower profile gear housing
- More powerful motor, improved DUSTGUARD protection
- New ergonomic design with rotating back handle
- Tool-free adjustable guard and spindle lock

Model No. TD925
Mfg. No. 30A190
Price/Each \$519.00

SPECIFICATIONS

Wheel Diameter: 9"
Voltage: 120 V
No Load RPM: 6000
Spindle Size: 5/8" - 11
Tool Weight: 12.8 lbs.



HIGH PERFORMANCE 6" GRINDER WITH SLIDE SWITCH

- Power Loss Reset® prevents accidental restarts following a power disruption when the tool is left in the "on" position
- Dust ejection system provides durability by ejecting damaging dust and debris particles that enter through the air intake vents
- E-Clutch™ activates in less than a tenth of a second when a pinch/stall is detected, shutting down the motor
- Includes: Side handle, inner and outer flange, 6" type 27 guard, 6" type 1 guard
- Power Tool Type: Corded

Model No. TYW993
Mfg. No. DWE43140
Price/Each \$299.00

SPECIFICATIONS

Wheel Diameter: 6"
Voltage: 120 V
Amperage: 13.0
Max. Watts Out: 1700 W
No Load RPM: 9000
Spindle Size: 5/8" - 11
Tool Weight: 6.2 lbs.



BRUSHLESS VARIABLE SPEED DIE GRINDER

- Brushless motor for long motor life and no brush changes
- Spindle lock button for quick accessory change
- Precision 1/4" collet with 1/8" reducing sleeve for gripping strength, allowing user to operate both 1/4" and 1/8" shaft accessories
- AC/DC capacity works off welding machines and generators for productivity and versatility
- Includes lanyard ready integrated solution to tether the tool to rigid structures when working at heights
- Kickback brake shuts down the motor and brings the wheel to a stop when a pinch/stall event is detected
- Includes: 2" Brushless variable speed die grinder, Wrench, 1/4" Collet, 1/8" Reducing sleeve
- Manufacturer's Warranty: 3 Year Limited



UAJ172



Model No.	Mfg. No.	Lock On Trigger	Collet Size"	No Load RPM	Tool Wt. lbs.	Price /Each
UAJ172	DWE4997NVS	No	1/4	6500 - 2500	6.0	479.00
UAJ173	DWE4997VS	Yes	1/4	6500 - 2500	6.0	479.00

HEAVY-DUTY 1 1/2" DIE GRINDERS

- AC/DC capacity works off welding machines and generators for increased productivity and versatility
- Convenient paddle switch with lock-on button for easy gripping
- Precision 1/4" collet with 1/8" reducing sleeve securely holds all proper accessories
- Includes: Two wrenches and 1/4" collet

Model No. TYK731
Mfg. No. DWE4887
Price/Each \$285.00

SPECIFICATIONS

Collet Size: 1/4"
Voltage: 120 V AC/DC
Amperage: 3.0
No Load RPM: 25 000
Tool Weight: 3.25 lbs.



DIE GRINDERS

- Low speed with very high torque, ideal for grinding and finishing work using brushes, flap discs and points
- Labyrinth dust proof construction prolongs tool life
- Electronic constant speed controller with soft start and variable speed dial
- Includes: Collet 1/4", two wrench and side handle set

Model No. TDU735
Mfg. No. GD0810C
Price/Each \$559.00

SPECIFICATIONS

Collet Size: 1/4"
Voltage: 120 V AC/DC
Amperage: 6.6
No Load RPM: 1800-7000
Tool Weight: 6.6 lbs.



Makita

HEAVY-DUTY 2" DIE GRINDERS

- All ball and roller bearing construction
- Ball-bearing mounted armature
- Sturdy aluminum gear case
- Helical cut alloy steel gears and shaft
- For mounted wheels up to 2", reinforced wheels up to 2"

Model No. TF421
Mfg. No. 5196
Price/Each \$519.00

SPECIFICATIONS

Collet Size: 1/4"
Voltage: 120 V AC/DC
Amperage: 11.0
No Load RPM: 14 500
Tool Weight: 7.8 lbs.



Milwaukee

12" DOUBLE BEVEL SLIDING COMPOUND MITER SAWS

DEWALT

- Integrated XPS cross cut positioning system provides adjustment-free cut line indication for better accuracy and visibility
- Powerful 15 amp motor delivers extended power and durability
- Super efficient dust collection system captures over 75% of dust generated
- Exclusive back fence design cuts up to 2 x 16 dimensional lumber at 90° and 2 x 12 at 45°
- Adjustable stainless steel miter detent plate with 10 positive stops
- Dual horizontal steel rails with innovative clamping mechanism and linear ball bearings
- Innovative gearbox and belt-drive design increases vertical cutting capacity
- Includes: Carbide blade, blade wrench, dust bag & vertical material clamp

Model No. TLV876
Mfg. No. DWS780
Price/Each \$999.00

SPECIFICATIONS

Voltage: 120
Amperage: 15.0
Arbor: 5/8" or 1"
Mitre Range: 50° Left and 60° Right
Tool Weight: 56.0 lbs.



10" SLIDING COMPOUND MITRE SAWS W/LASER

KING
 CARBIDE

- Twin laser guide system indicates the cut line on both sides of the blade kerf for reliable cuts every time
- Dual rail sliding system for sturdy, accurate and smooth sliding action
- Rotating table has nine positive stops at 0°, 15°, 22.5°, 30° and 45° right and left
- Includes: 2-position vertical hold down vise, retractable extension wings, dust bag and blade socket wrench

Model No. TBS757
Mfg. No. 8380
Price/Each \$335.00

SPECIFICATIONS

Amperage: 15.0
No Load RPM: 5200
Arbor: 5/8"
Mitre Range: 45° Left to 45° Right
Bevel Range: 45° Left to 0° Right
Tool Weight: 40.0 lbs.



12" SINGLE BEVEL COMPOUND MITER SAWS

DEWALT

- Features stainless steel miter detent plate and cam miter lock
- Designed to provide repeatable accuracy and durability
- Features lightweight design and carrying handle for easy portability
- Includes: Compound miter saw, 12" carbide tipped blade, wrench, dust bag, and vertical clamp

Model No. UAE025
Mfg. No. DWS715
Price/Each \$535.00

SPECIFICATIONS

Blade Diameter: 12"
No Load RPM: 4000 RPM
Amps: 15 A
Voltage: 120 V
Mitre Range: 50° Left/50° Right
Bevel Range: 48° Left/3° Right
Weight: 36 lbs.



RMP
 PRODUITS D'ENTRETIEN • MAINTENANCE PRODUCTS

CORDED POWER TOOLS

14" CUT-OFF SAWS

- Metal-cutting solution built for light gauge metal stud and strut, pipe, all thread, conduit, tubing, rebar, and more
- Features an extra-large spark guard, and a "tool-less" flange removal for faster blade changes and ease-of-use
- Two "tool-less" adjustment features including the fence and vice adjustment for increased productivity
- Large ergonomic handle and two-stage lock-off power button

Model No. UAD800
Mfg. No. LW1400
Price/Each \$379.00

SPECIFICATIONS

Blade Diameter: 14"
No Load RPM: 3800
Amps: 15 A
Voltage: 120 V
Motor Horse Power: 2 HP
Cutting Capacity
Rectangular: 7-5/8"
Round: 5"



14" INDUSTRIAL CHOP SAWS

- Compact, well balanced and easy to use
- Spindle lock button allows for hassle free blade change
- Guiding notches give good cut line visibility
- Powerful 1400 watt motor allows the saw to cut up to 6mm steel plate without coolant
- Quick and easy depth adjustment
- Rubber rear grip gives maximum comfort and grip to the user

Model No. UAF510
Mfg. No. D28730
Price/Each \$339.00

SPECIFICATIONS

Blade Diameter: 14"
No Load RPM: 3800
Amps: 15 A
Voltage: 240 V
Motor Horse Power: 4 HP
Cutting Capacity
Round: 5"



14" CHOP SAWS KEYLESS BLADE CHANGE

- 45° adjustable fence allows angle cuts without using a wrench
- Soft start extends gear and motor life
- Includes: 14" abrasive wheel, fence wrench and tool free flange system

Model No. TJZ872
Mfg. No. D28715
Price/Each \$395.00

SPECIFICATIONS

Amperage: 15.0
Motor Horsepower: 5.5
No Load RPM: 4000
Blade Diameter: 14"
Cutting Capacity
Round: 5"
Rectangle: 4 1/2" x 6 1/2"
Tool Weight: 39.0 lbs.



HEAVY-DUTY 14" MULTI-CUTTER SAWS

- Cuts a wide variety of materials including ferrous and non-ferrous metals
- Depth of cut remains constant for carbide tipped blade
- Includes: 14" carbide tipped blade, wrench and vertical clamp

Model No. UG967
Mfg. No. DW872
Price/Each \$949.00

SPECIFICATIONS

Amperage: 15.0
Motor Horsepower: 4.0
No Load RPM: 1300
Blade Diameter: 14"
Cutting Capacity
Round: 5 3/16"
Rectangle: 4 1/2" x 6 1/2"
Tool Weight: 47.0 lbs.



14" ABRASIVE CHOP SAWS

- Powerful 15 Amp, 4.0 max. HP motor: Delivers maximum cutting performance in a wide variety of materials
- Large cutting capacity: Provides versatility for a wide range of cutting applications, up to 5" pipe
- 45° miter capacity with adjustable fence
- Quick adjust vise clamp: Allows clamp to be adjusted quickly when cutting different material sizes
- All ball bearing construction: Delivers maximum durability
- Includes: Vise, abrasive wheel and hex wrench

Model No. TLV202
Mfg. No. 6177-20
Price/Each \$319.00

SPECIFICATIONS

Amperage: 15.0
Motor Horsepower: 4.0
No Load RPM: 3900
Blade Diameter: 14"
Tool Weight: 40.0 lbs.



PERFORMANCE PLUS 14" CHOP SAWS

- Ball bearing induction motor
- Spark deflector for safe operation
- Quick release vise for holding workpiece, which allows cuts up to a 45° angle

Model No. WK772
Mfg. No. 8342N
Price/Each \$239.00

SPECIFICATIONS

Amperage: 15.0
No Load RPM: 3750
Blade Diameter: 14"
Max. Depth of Cut: 4"
Max. Width of Cut: 7 1/4"
Tool Weight: 45.0 lbs.



12" COMPOUND MITRE SAWS

- Positive stops at nine settings; 15°, 22.5°, 31.6°, 45°, left and right and 0° mitre cuts
- Horizontal D-handle design
- Includes: Carbide blade, socket wrench, dust bag, triangular rule, two holders and vertical vise

Model No. TDU772
Mfg. No. LS1221
Price/Each \$559.00

SPECIFICATIONS

Amperage: 15.0
No Load RPM: 4000
Arbor: 1"
Mitre Range: 48° Left to 48° Right
Bevel Range: 45° Left to 0° Right
Tool Weight: 36.4 lbs.



10" DUAL SLIDING COMPOUND MITRE SAWS W/LASER



- Sliding rail mechanism incorporating three linear ball bearings
- Sliding fence (left side) can be adjusted outwards when bevel cutting or inwards for increased support of small or delicate materials
- Battery operated, factory calibrated Class 2 laser
- Bevel capacity of 45° left or right
- Mitre capacity of 47° left or 60° right with positive stops at 0°, 15°, 22.5°, 31.6° and 45°
- 2-stage safety switch for increased operator safety
- Includes: 10" mitre saw blade 40CT, box wrench, dust bag, vertical vise, triangle rule, 2 ea. holder

Model No. TLV225
Mfg. No. LS1018L
Price/Each \$759.00

SPECIFICATIONS

Amperage: 13.0
No Load RPM: 4300
Arbor: 5/8"
Mitre Range: 47° Left to 60° Right
Bevel Range: 45° Left to 45° Right
Soft Start: Yes
Tool Weight: 43.7 lbs.



12" SLIDING COMPOUND MITRE SAWS

- Rail forward design
- Integrated guide fence and lower fence
- Front bevel knob
- Constant speed control maintains constant speed under heavy load
- Soft start feature gradually
- Electric brake
- Easy-to-operate mitre angle lock
- Horizontal handle design with 2-stage safety switch for increased operator safety
- Ergonomic horizontal soft rubber grip design for vibration absorption and comfortable operation
- Includes: 12" C.T. Blade 60T, Dust Bag, Vertical Vise, Triangle Rule, Two Holder 200, Holder 90, Hex Wrench 6

Model No. UAD702
Mfg. No. LS1219
Price/Each \$1039.00



SPECIFICATIONS

Blade Diameter: 12"
No Load RPM: 3200
Amps: 15 A
Voltage: 120 V
Mitre Range: 60° Left/60° Right
Bevel Range: 60° Left/60° Right
Arbor: 1"
Vibration Level: 2.5 m/s²
Noise Level: 91 dB(A)



10" COMPOUND MITRE SAWS

- Positive stops at nine settings; 15°, 22.5°, 31.6°, 45°, left and right and 0° mitre cuts
- Precision machined aluminum base
- Shaft lock for easy blade changes
- Includes: Cross-out blade, dust bag, triangular rule and socket wrench

Model No. VK963
Mfg. No. LS1040
Price/Each \$429.00



SPECIFICATIONS

Positive mitre detents: 0°, 15°, 22.5°, 31.6° and 45° left and right
Mitre range: 45° left, 52° right
Bevel range: 45° left, 45° right
Vertical cap.: 2 3/4"
Horizontal cap.: 5 1/8"
No load speed: 4600 RPM
Arbor Size: 5/8"
Motor: 120 V AC, 15.0 A
Weight: 24.2 lbs.
Blade Diameter: 10"



12" DOUBLE-BEVEL COMPOUND MITRE SAWS

- Stainless steel mitre detent plate with 14 positive stops delivers repeatable accuracy and worksite durability
- Double-bevel design allows saw to bevel 0° - 48° to the left and right with positive stops at 0°, 22.5°, 33.9°, and 45°
- Cam lock mitre handle with detent override delivers quick and accurate mitre angles
- Tall sliding fences support crown molding up to 6-5/8" nested and base molding up to 6-1/2" vertically against fence
- High-efficiency dust duct
- Lightweight design and built-in carry handle provide portability
- **UAG298:** Cutline™ LED work light system provides adjustment-free cut line indication for accuracy and visibility

SPECIFICATIONS

Blade Diameter: 12"
No Load RPM: 3800
Amps: 15 A
Mitre Range: 50° Left/50° Right
Bevel Range: 48° Left/48° Right
Arbor Size: 5/8" or 1"
Weight: 41 lbs.



Model No.	Mfg. No.	Description	Price/Each
UAG297	DWS716	Saw without Worklight	679.00
UAG298	DWS716XPS	Saw with Worklight	715.00

10" SLIDING COMPOUND MITRE SAWS

- Rail forward design
- 3-stage gear reduction system greatly increases capacity when cutting vertical baseboard or nested crown molding
- 1-3/16" guide rail diameter provides increased stability and cutting precision
- Integrated guide fence and lower fence
- Front bevel knob
- Electronic speed control maintains constant speed under heavy load
- Soft start feature
- Easy-to-operate mitre angle lock with free spin lever a
- Horizontal handle design with 2 stage safety switch for increased operator safety
- Ergonomic horizontal soft rubber grip design for vibration absorption and comfortable operation
- Includes: 10" C.T. Blade 60T, Hex Wrench 6, Dust Bag, Vertical Vise, Triangle Rule, Dust Nozzle, Two Holders, Wrench Holder

Model No. UAD701
Mfg. No. LS1019
Price/Each \$939.00

SPECIFICATIONS

Blade Diameter: 10"
No Load RPM: 3200
Amps: 15 A
Voltage: 120 V
Mitre Range: 60° Left/60° Right
Bevel Range: 60° Left/60° Right
Arbor: 5/8"
Vibration Level: 2.5 m/s²
Noise Level: 91 dB(A)



CORDED POWER TOOLS



7 1/4" CIRCULAR SAWS W/HIGH STRENGTH BASE

- High strength base will withstand a one story drop
- 56° beveling capacity with stops at 45° and 22.5°
- Electric brake stops blade after use
- Includes: Carbide tipped blade, blade wrench and contractor bag

Model No. TSW598
Mfg. No. DWE5755B
Price/Each \$289.00

SPECIFICATIONS

Amperage:	15.0
No Load RPM:	5200
Depth of Cut at 45°:	1 3/4"
Depth of Cut at 90°:	2 1/2"
Tool Weight:	8.8 lbs.



8" METAL CUTTING SAWS

- Durable blade shield with integral chiptank deflects hot chips and sparks
- Quick-release shield latch for fast waste disposal and blade changes
- Lever's location ensures user has both hands firmly on the saw
- Includes: Case, circular saw blade and hex blade wrench

Model No. TEX280
Mfg. No. 6370-21
Price/Each \$579.00

SPECIFICATIONS

Amperage:	13.0
No Load RPM:	3700
Depth of Cut at 90°:	2 9/16"
Tool Weight:	13.3 lbs.



WORM DRIVE 7 1/4" CIRCULAR SAWS

- Lightweight magnesium and aluminum construction including durable magnesium foot plate
- Extra wide saw hook accepts materials up to 2-3/4"
- ToughCord™ cord protection system with cord jerk protection
- Electric brake stops the blade after trigger is released
- Accepts DWS5100 Dual Port Rip Guide (sold separately)
- Includes: Worm drive circular saw with grounded plug, 7-1/4" Carbide blade, Blade changing wrench

Model No. UA1800
Mfg. No. DWS535B
Price/Each \$349.00

SPECIFICATIONS

Blade Diameter:	7-1/4"
No Load RPM:	4800
Amps:	15 A
Voltage:	120 V
Bevel Capacity:	53°
Bevel Stops:	22.5°, 45°



8 1/4" CIRCULAR SAWS

- High performance magnesium blade casing and base
- Bevel adjustment with positive stops at 22.5°, 45°, and 50°
- Electric brake, two built in LED lights, rubberized grips
- Includes: Carbide tipped blade, guide rule, hex wrench

Model No. TLY363
Mfg. No. 5008MCA
Price/Each \$349.00

SPECIFICATIONS

Amperage:	15.0
No Load RPM:	5200
Depth of Cut at 45°:	2 1/4" (2" at 50°)
Depth of Cut at 90°:	3
Tool Weight:	11.2 lbs.



7 1/4" CIRCULAR SAWS

- High power, maximum cutting depth of 2 1/2"
- Electric brake, twin LED lights, heavy gauge aluminium base with ruler markings
- Bevel adjustment with positive stops at 22.5° and 45°
- Includes: Guide rule, hex wrench, carbide tipped black M-Force saw blade

Model No. TLV574
Mfg. No. 500FA
Price/Each \$245.00

SPECIFICATIONS

Amperage:	15.0
No Load RPM:	5800
Depth of Cut at 45°:	1 3/4" (1 3/8" at 50°)
Depth of Cut at 90°:	2 1/2"
Tool Weight:	11.1 lbs.



7 1/4" CIRCULAR SAWS

- Heavy-duty aluminum base plate for jobsite durability
- Well balanced design for better control from above or behind the saw
- Bevel capacity of 45°
- Includes: 1 ea. 7-1/4" Blade 24T, Wrench 13 (782016-4)

Model No. TF382
Mfg. No. 5007NB
Price/Each \$199.00

SPECIFICATIONS

Amperage:	15.0
No Load RPM:	5800
Depth of Cut at 45°:	1 3/4"
Depth of Cut at 90°:	2 3/8"
Tool Weight:	11.2 lbs.



COMPACT JOBSITE TABLE SAW

- Compact size for easy transportation and storage
- Rack and pinion telescoping fence rails make fence adjustments fast, smooth, and accurate
- 24.5" of rip capacity for ripping 4x8 plywood or OSB sheets
- Power-loss reset prevents accidental restarts following a power disruption when the tool is left in the on position
- Metal roll cage base for jobsite durability
- Site-Pro Modular Guarding System allows for tool-free adjustments of the guarding
- On-board storage for guard, fence, wrenches, and miter gauge
- Blade brake
- Overall Dim.: 26-3/4" L x 14-9/50" W x 27-1/4" H
- Manufacturer's Warranty: 3-Year Limited Warranty
- Includes: (1) 8-1/4" Table Saw, (1) 8-1/4" Blade, (1) Fence, (1) Non-Through Cut Riving Knife, (1) Anti-Kickback Pawls, (1) Blade-Change Wrenches, (1) Miter Gauge, (1) Modular Guard System, (1) Push Stick

Model No. AUW216
Mfg. No. DWE7485
Price/Each \$669.00

SPECIFICATIONS

Voltage:	120 V
Amperage:	15
No Load RPM:	5800
Max. Depth of Cut at 90°:	2.563"
Max. Depth of Cut at 45°:	1.75"
Blade Diameter:	8-1/4"
Max. Ripping Capacity:	24.5"
Tool Weight:	53.4 lbs.



ORBITAL JIG SAWS

- Keyless shoe adjustment with 45° in both directions and orbital action with four adjustment levels
- Quik-Lok™ blade change system and built-in dust collection port
- Tachometer feedback for constant cutting speed
- Includes: Dust shield and two blades

Model No. TKZ868
Mfg. No. 6268-21
Price/Each \$425.00

SPECIFICATIONS

Amperage:	6.5
Stroke Length:	1"
Strokes per Minute (SPM):	0-3000
Tool Weight:	6.4 lbs.

Milwaukee



SUPER SAWZALL®

- Maintains constant speed under load
- Variable speed trigger and dial speed control
- Quik-Lok™ blade clamp, tool-less blade change and impact protection
- Includes: Carrying case and one blade

Model No. TLY299
Mfg. No. 6538-21
Price/Each \$385.00

SPECIFICATIONS

Stroke Length:	1 1/4"
Amperage:	15.0
Strokes per Minute:	0-2800
Tool Weight:	9.8 lbs.

Milwaukee



JIG SAWS

- Uses tang style blades only
- Variable speed, vacuum port, three orbital settings plus straight cutting
- Adjustable base bevels from 0°-45° left and right
- Includes: One jig saw blade and carrying case

Model No. TLY335
Mfg. No. 4329K
Price/Each \$169.00

SPECIFICATIONS

Amperage:	3.9
Stroke Length:	11/16"
Strokes per Minute (SPM):	500-3100
Tool Weight:	4.2 lbs.

Makita



RECIPROCATING SAWS

- Powered by a 12 Amp motor with electronic speed control to maintain constant speed under load
- Variable speed trigger to match the speed of the saw to the application
- Durable body design that keeps dust and debris away from the motor, with rubber and felt seals to keep dust and water out for a longer tool life
- "Tool-less" blade change for fast blade installation and removal
- Engineered for demolition, metal cutting, wood cutting, drywall and plaster, plastics, and remodeling
- Tool hook secures the tool when not in use
- Well balanced design (only 7.3 lbs. and 17-5/8" long) for reduced operator fatigue and all-day use
- Large 2-finger trigger for added convenience
- Soft grip and handle for increased comfort
- Double insulated
- Includes: Reciprocating saw, 6" 6 TPI Wood-cutting saw blade, 6" 18 TPI Metal-cutting saw blade

Model No. UAJ532
Mfg. No. JR3051T
Price/Each \$175.00

SPECIFICATIONS

Stroke Length:	1-3/16"
Strokes per Minute (SPM):	0-3000
Amps:	12 A
Overall Length:	17-5/8"
Net Weight:	7.3 lbs.
Max. Cutting Capacity:	5-1/8" Pipe & 10" Wood

Makita



DEEP CUT BAND SAWS

- Variable speeds dial and trigger and 2-finger variable speed trigger
- Adjustable material guide
- Rear blade guard - 30% thicker steel protects the guard from bending or pinching during material break-through
- Includes: Carrying case

Model No. TLV447
Mfg. No. 6232-21
Price/Each \$505.00

SPECIFICATIONS

Amperage:	10.5
Saw Surface Feet per Minute (SFPM):	0-420
Max Capacity	
Rectangular:	4 7/8" x 4 7/8"
Round:	4 7/8"
Tool Weight:	17.5 lbs.

Milwaukee



DEEP CUT PORTA-BAND® SAWS

- Dual bearing blade guide rollers increase durability in the blade support system
- Speed control knob allows to tailor the blade speed
- Blade tracking adjustment increases blade life
- Includes: Hex wrench and standard blade

Model No. TKZ842
Mfg. No. DWM120K
Price/Each \$735.00

SPECIFICATIONS

Amperage:	10.0
Saw Surface Feet per Minute (SFPM):	100-350
Max Capacity	
Rectangular:	5" x 4 3/4"
Round:	5"
Tool Weight:	14 lbs.

DEWALT



ANTI-VIBRATION RECIPROCATING SAWS

- Features anti-vibration technology (AVT)
- Orbital change lever offers three stages and one straight cutting action
- Accepts standard 1/2" shank blades
- Includes: One saw blade and carrying case

Model No. TGX675
Mfg. No. JR3070CT
Price/Each \$425.00

SPECIFICATIONS

Stroke Length:	1 1/4"
Amperage:	15.0
Strokes per Minute:	0-2800
Tool Weight:	9.5 lbs.

Makita



SAWZALL® RECIPROCATING SAWS

- Powerful 12 Amp motor: Delivers 0-3000 SPM for high performance cutting in a variety of materials
- 1 1/8" stroke length
- Counter weighted mechanism: Provides reduced vibration for smoother operation
- Quik-Lok™ blade clamp for fast, tool-less blade changes
- Includes: Carrying case

Model No. TLV201
Mfg. No. 6519-31
Price/Each \$235.00

SPECIFICATIONS

Stroke Length:	1 1/8"
Amperage:	12.0
Strokes per Minute:	0-3000
Tool Weight:	7.1 lbs.

Milwaukee



CORDED POWER TOOLS

SAWZALL® RECIPROCATING SAWS

- Powerful 12 Amp motor: Delivers 0-3000 SPM for high performance cutting in a variety of materials
- 3/4" stroke length
- Counter weighted mechanism: Provides reduced vibration for smoother operation
- Quik-Lok™ blade clamp: Provides fast, tool-free blade changes
- Includes: Carrying case

Model No. TLV200
Mfg. No. 6509-31
Price/Each \$229.00

SPECIFICATIONS

Stroke Length: 3/4"
Amperage: 12.0
Strokes per Minute: 0-3000
Tool Weight: 7.1 lbs.



Milwaukee

1/2" IMPACT WRENCHES

- Pin-detent system to retain sockets or adapters and a rocker switch for quick selection of forward or reverse
- Ergonomic handle with a soft cushioned grip provides a well-balanced and controllable feel to the tool
- Rocker switch for quick selection of forward and reverse

Model No. WJ082
Mfg. No. 9070-20
Price/Each \$325.00

SPECIFICATIONS

Socket Size: 1/2"
Amperage: 7.0
Torque: 300 ft.-lbs.
No Load RPM: 0-4000
No Load IPM: 2600
Tool Weight: 6.0 lbs.



Milwaukee

RECIPROCATING SAWS

- Powerful motor designed for heavy-duty applications
- Keyless, lever-action blade clamp for quick and easy blade changes
- 4-position blade clamp allows for flush cutting and increased versatility
- Variable speed trigger allows user to instantly control speed

Model No. TYL342
Mfg. No. DWE305
Price/Each \$199.00

SPECIFICATIONS

Stroke Length: 1 1/8"
Voltage: 120
Amperage: 12.0
Strokes per Minute: 0-2900
Tool Weight: 7.2 lbs.



DEWALT

1/2" IMPACT WRENCHES

- Heavy-duty aluminum gear housing
- Rubber inlay grip reduces vibration
- Rocker switch for forward and reverse
- Includes: Plastic carrying case

Model No. TDX437
Mfg. No. TW0350
Price/Each \$415.00

SPECIFICATIONS

Socket Size: 1/2"
Amperage: 3.5
Torque: 258.2 ft.-lbs.
No Load RPM: 2000
No Load IPM: 2000
Tool Weight: 6.4 lbs.



Makita

3/4" IMPACT WRENCHES

- Rocker switch for quick selection of forward and reverse
- Friction ring socket retention
- Light weight with balanced feel and cushioned grip

Model No. TEA202
Mfg. No. 9075-20
Price/Each \$505.00

SPECIFICATIONS

Socket Size: 3/4"
Amperage: 7.0
Torque: 380 ft.-lbs.
No Load RPM: 1750
No Load IPM: 2500
Tool Weight: 6.2 lbs.



Milwaukee

IMPACT WRENCH WITH ROCKER SWITCH

- Cord Type: 8' fixed
- Tool warranty: 5 years
- Includes: Tool only
- With friction ring socket retention
- Rocker switch enables quick selection of forward and reverse
- Friction ring socket retention system reduces downtime on applications involving frequent changing of accessories

Model No. TEA201
Mfg. No. 9071-20
Price/Each \$325.00

SPECIFICATIONS

Socket Size: 1/2"
Amperage: 7.0
Torque: 300 ft.-lbs.
No Load RPM: 1800
No Load IPM: 2700
Tool Weight: 7.0 lbs.



Milwaukee

3/4" IMPACT WRENCHES

- Rocker reversing switch for one handed forward/reverse operation
- Side handle adjusts 360°
- Heavy duty rubber bumper in front
- Includes: Steel carrying case and grip assembly

Model No. TF646
Mfg. No. 6906
Price/Each \$869.00

SPECIFICATIONS

Socket Size: 3/4"
Amperage: 9.0
Torque: 433 ft.-lbs.
No Load RPM: 1500
No Load IPM: 1600
Tool Weight: 11.0 lbs.



Makita

3/8" VSR DRILLS

- Durable all ball-bearing construction
- Textured handle provides better gripping surface
- Glass-filled nylon housing is durable and impact resistant
- Includes: Kit bag

Model No. TLV567
Mfg. No. DWD110K
Price/Each \$139.00

SPECIFICATIONS

Chuck Size: 3/8"
Amperage: 8.0
No Load RPM: 0-2500
Chuck Type: Keyless
Tool Weight: 4.1 lbs.



DEWALT

1/2" VSR DRILLS

- Single-sleeve keyless chuck with spindle lock
- Triple gear reduction provides increased torque
- Helical-cut steel, heat-treated gears for increased durability
- Includes: 360° locking side handle

Model No. TD936
Mfg. No. DW246
Price/Each \$329.00

SPECIFICATIONS

Chuck Size: 1/2"
Amperage: 7.8
No Load RPM: 0-600
Chuck Type: Keyless
Tool Weight: 4.4 lbs.



DEWALT

1/2" MAGNUM® DRILLS

- Powerful 8.0 Amp motor with variable speed control
- All metal gear case and diaphragm
- 8' 3-wire rubber cord and 360° locking side handle
- Includes: Side handle and chuck key with holder

Model No. TEA090
Mfg. No. 0299-20
Price/Each \$229.00

SPECIFICATIONS

Chuck Size: 1/2"
Amperage: 8.0
No Load RPM: 0-850
Chuck Type: Keyed
Tool Weight: 5.4 lbs.



Milwaukee

1/2" SPADE HANDLE DRILLS

- Variable speed reversing switch avoids air bubbles when mixing mud and offers greater control
- 0-550 RPM provides increased torque for drilling and mud mixing
- Soft grip handle provides comfort and ergonomics
- Includes: 3-position side handle, chuck key with holder and 2-position rear spade handle

Model No. TKZ843
Mfg. No. DW130V
Price/Each \$299.00

SPECIFICATIONS

Chuck Size: 1/2"
Amperage: 9.0
No Load RPM: 0-550
Chuck Type: Keyed
Tool Weight: 7.5 lbs.



DEWALT

1/2" DRILLS

- Industrial aluminum gear housing for durability
- Large reversing switch and lock-on button
- Convenient belt clip
- Includes: Side handle and chuck key

Model No. TW242
Mfg. No. 6303H
Price/Each \$255.00

SPECIFICATIONS

Chuck Size: 1/2"
Amperage: 6.5
No Load RPM: 0-850
Chuck Type: Keyed
Tool Weight: 4.8 lbs.



Makita

1/2" VSR DRILLS

- Triple gear reduction provides increased torque
- Metal gear housing for jobsite durability
- Helical-cut steel, heat-treated gears for increased durability
- Includes: 360° side handle and chuck key with holder

Model No. TD935
Mfg. No. DW245
Price/Each \$335.00

SPECIFICATIONS

Chuck Size: 1/2"
Amperage: 7.8
No Load RPM: 0-600
Chuck Type: Keyed
Tool Weight: 4.4 lbs.



DEWALT

3/8" ANGLE DRILLS

- Built-in LED job light and reduced head height (2 5/8")
- Compact (10 5/8" length) design for close quarters
- Paddle switch with speed limiting dial
- Includes: Grip and chuck key with holder

Model No. TF811
Mfg. No. DA3010F
Price/Each \$415.00

SPECIFICATIONS

Chuck Size: 3/8"
Amperage: 4.0
No Load RPM: 0-2400
Chuck Type: Keyed
Tool Weight: 3.1 lbs.



Makita

1/2" COMPACT DRILLS

- Made for two handed operation
- Rear mounted assist spade handle
- Heat treated gears are helical-cut for quiet performance
- Includes: Pipe handle

Model No. TF092
Mfg. No. 1660-6
Price/Each \$415.00

SPECIFICATIONS

Chuck Size: 1/2"
Amperage: 7.0
No Load RPM: 0-500
Chuck Type: Keyed
Tool Weight: 11.4 lbs.



Milwaukee

CORDED POWER TOOLS

1/2" CORDED DRILL

- Variable speed feature enables operator to adjust speed to suit various materials and applications
- Ideal for mixing thin-set mortar, drywall compound, masonry, paint and more!
- Increased continuous input rating, rated amperage and no load speed for added Improved motor cooling for added durability and operational efficiency
- Aluminum gear housing
- Conveniently located forward / reverse switch
- Lock-on button enables easy continuous operation
- Rear handle rotates 360° with 24 locking positions
- Removable side handle
- Lanyard loop provides secure attachment of safety / security lanyards
- Ergonomic soft rubber grip for vibration absorption and comfortable operation

Model No. TYL192
Mfg. No. DS4012
Price/Each \$279.00



SPECIFICATIONS

Chuck Size: 1/2"
Amperage: 8.5
No Load RPM: 600
Chuck Type: Keyed
Tool Weight: 6.2 lbs.

1/2" VSR DUAL RANGE HAMMER DRILLS

- High/low speed for high speed drilling or high torque applications
- 8.2 Amp motor provides high performance and overload protection
- 360° side handle with depth rod offers greater control
- Includes: 360° side handle, depth rod and chuck key with holder

Model No. TKZ841
Mfg. No. DW520K
Price/Each \$339.00



SPECIFICATIONS

Chuck Size: 1/2"
Amperage: 10
No Load RPM: 0-1200/0-3500
No Load BPM: 0-56000
Chuck Type: Keyed
Tool Weight: 6.0 lbs.

POWER SCRAPERS

- Quick change bit retainer for easy changes
- Motor has auto shut-off feature when brushes must be replaced
- Factory grease packed for approximately 200 hours of maintenance free operation
- Includes: 1 3/16" and 2" scaling chisels, bull point, dust cover and plastic carrying case

Model No. TF850
Mfg. No. HK1820
Price/Each \$845.00



SPECIFICATIONS

Amperage: 5.0
No Load BPM: 0-3200
Impact Energy: 2.9 ft.-lbs.
Tool Weight: 7.5 lbs.

1/2" VSR HAMMER DRILLS

- Lightweight design for less user fatigue
- Dual mode hammer drill/drill for wood, steel or masonry applications
- Variable speed allows for precise hole placement on work surface
- Includes: 360° side handle, depth rod and chuck key with holder

Model No. TSW576
Mfg. No. DW511
Price/Each \$219.00



SPECIFICATIONS

Chuck Size: 1/2"
Amperage: 6.7
No Load RPM: 0-2700
No Load BPM: 0-46000
Chuck Type: Keyed
Tool Weight: 4.3 lbs.

1/2" VSR DUAL RANGE HAMMER DRILLS

- High/low speed for high speed drilling or high torque applications
- Lightweight design for less user fatigue
- 360° side handle with depth rod offers greater control
- Includes: Side handle, chuck key and plastic carrying case

Model No. TD944
Mfg. No. DW505K
Price/Each \$279.00



SPECIFICATIONS

Chuck Size: 1/2"
Amperage: 7.8
No Load RPM: 0-1100/0-2700
No Load BPM: 0-19000/0-46000
Chuck Type: Keyed
Tool Weight: 4.8 lbs.

1" D-HANDLE SDS ROTARY HAMMER

- SHOCKS - Active Vibration Control® reduces vibration felt by the user at the handles
- Variable speed trigger allows user to instantly control speed
- Mode selector allows for usage in rotary hammer, rotary only, and chiseling applications
- Reversing feature helps release tool from bind up situations, and assists with removal of fasteners
- 360 degree side handle adjusts easily for preference or use in tight spaces

Model No. TLV939
Mfg. No. D25263K
Price/Each \$445.00

SPECIFICATIONS

Solid Bit Capacity: 5/32" - 5/8"
Amperage: 8.0
No Load RPM: 0-1150
No Load BPM: 0-4300
Impact Energy: 2.1 ft.-lbs.
Tool Weight: 7.0 lbs.



SDS PLUS ROTARY HAMMER KITS

- Thin Wall Core Bit Capacity: 3"
- Vibration: 10.6 m/s²
- Drilling mode: 3-mode: Rotary hammer, hammer only, rotation only
- Get up to 85% faster drilling and 85% harder hitting while reducing vibration
- Equipped with an all metal gear case and mechanical clutch to provide maximum durability
- Powerful and lightweight
- Kit includes a side handle, depth rod and carrying case

Model No. TYO341
Mfg. No. 5268-21
Price/Each \$575.00

SPECIFICATIONS

Solid Bit Capacity: 1 1/8"
Amperage: 8.0
No Load RPM: 0-1500
No Load BPM: 0-5500
Impact Energy: 3.6 ft.-lbs.
Tool Weight: 7.5 lbs.



Milwaukee

7/8" SDS PLUS ROTARY HAMMER KIT

- Three modes of operation: Rotary hammer, hammer only and rotation only
- Mechanical clutch: Protects the motor when the bit binds
- Variable position chisel stop: Allows material to be adjusted, regardless of orientation
- Includes: (1) Carrying case, (1) depth rod, (1) side handle

Model No. TLV204
Mfg. No. 5262-21
Price/Each \$345.00

SPECIFICATIONS

Solid Bit Capacity: 7/8"
Amperage: 7.0
No Load RPM: 0-1500
No Load BPM: 0-5625
Impact Energy: 1.8 ft.-lbs.
Tool Weight: 5.8 lbs.



Milwaukee

SDS MAX ROTARY HAMMERS

- Thin wall core bit capacity: 4"
- Drilling mode: 2-mode: Rotary hammer and hammer only
- Heavy-duty 5.5 ft.-lbs. of impact energy for solid performance
- Constant Power Technology ensures consistent drilling power for the toughest applications
- A 12-position chipping adjustment lets you maintain the optimum hammer position while chipping in any orientation
- A mechanical clutch protects the motor when the bit binds
- Two-mode operation offers maximum versatility regardless of the application
- Tool comes with a side handle and carrying case

Model No. TMB675
Mfg. No. 5317-21
Price/Each \$765.00

SPECIFICATIONS

Solid Bit Capacity: 1 9/16"
Amperage: 10.5
No Load RPM: 0-450
No Load BPM: 0-3000
Impact Energy: 5.5 ft.-lbs.
Tool Weight: 15 lbs.



Milwaukee

L-SHAPE SDS PLUS ROTARY HAMMER

- Wide optimal drilling range for a single-hammer solution
- SHOCKS Active Vibration Control® technology reduces vibration felt at the handles for less user fatigue and greater productivity
- Factory-set clutch reduces sudden, high-torque reactions if bit jams
- Variable speed trigger for accurate hole starting
- Optimized ergonomic design provides excellent control in all orientations
- OSHA Table 1 Compliant dust extraction compatible
- Includes: Rotary Hammer D25333, Kit Box

Model No. UAD826
Mfg. No. D25333K
Price/Each \$519.00

SPECIFICATIONS

Bit Capacity: 3/16" - 7/8"
Amps: 8.5 A
No Load BPM: 0-5200 BPM
No Load RPM: 0-1150 RPM
Impact Energy: 2.58 ft.-lbs.
Power Tool Type: Corded
Tool Weight: 8.16 lbs.



DeWALT

DEMOLITION HAMMERS W/ANTI-VIBRATION

- Anti-Vibration Technology enabled to reduce fatigue and injury due to exposure to vibration
- Extra long auto cut off carbon brushes provides reduced maintenance
- Electronic speed and variable control gives efficient hammering at the desired speed
- Includes: Side handle, bull point and carrying case

Model No. TLY750
Mfg. No. HM1214C
Price/Each \$1715.00

SPECIFICATIONS

Amperage: 14.0
BPM: 950-1900
Impact Energy: 18.95 ft.-lbs.
Tool Weight: 27.1 lbs.



Milwaukee



Makita

PAVEMENT BREAKERS

- Active Vibration Control reduces user fatigue and increases comfort and productivity
- Electronic soft start increases productivity by reducing bit walking
- Rubber coated handles provide greater comfort and control

Model No. TLY751
Mfg. No. D25980
Price/Each \$3455.00

SPECIFICATIONS

Amperage: 15.0
BPM: 900
Impact Energy: 61 ft.-lbs.
Tool Weight: 68.3 lbs.



DeWALT

CORDED POWER TOOLS



2" SDS MAX ROTARY HAMMERS

- Heavy-duty robust construction, digs and drills under the most demanding jobsite conditions
- Three handle positions offer greater user comfort
- System of vibration absorption/reduction reduces operator fatigue
- The side handle can be attached to the rear switch handle which minimizes bending over
- Includes: Side handle and carrying case



Model No. TFX202
Mfg. No. 5342-21
Price/Each \$1759.00

SPECIFICATIONS

Solid Bit Capacity: 2"
Amperage: 15.0
No Load RPM: 125-250
No Load BPM: 975-1950
Impact Energy: 19.9 ft.-lbs.
Tool Weight: 27.75 lbs.

HIGH SPEED VSR DRYWALL SCREW GUNS

- Depth-sensitive nosepiece for consistent fastener depth
- Two-finger trigger
- Helical-cut, heat-treated gears for durability



Model No. TSW573
Mfg. No. DW255
Price/Each \$155.00

SPECIFICATIONS

Amperage: 6.0
No Load RPM: 0-5300
Tool Weight: 2.9 lbs.

DRYWALL SCREW GUNS

- Variable speed control
- Ramp-off depth locator for easy depth adjustments
- Ergonomic tactile grip and two finger trigger for user comfort and balance
- Includes: Belt clip



Model No. WJ087
Mfg. No. 6742-20
Price/Each \$159.00

SPECIFICATIONS

Amperage: 6.5
No Load RPM: 0-4000
Tool Weight: 3.5 lbs.

PROFESSIONAL HEAT GUN

- Variable heat settings and two fan speeds provide maximum versatility for a variety of jobs
- Double insulated for user safety
- Flat back design permits user to stand gun on workbench for hands-free use
- Complete with 5 common accessories
- Convenient blow mould case protects tool and keeps accessories organized
- 1500 Watts maximum power
- cUL approved
- Temperature: 122°F - 842°F (50°C - 450°C)
- Fan Speeds: 10 CFM, 18 CFM



Model No. UAV922
Mfg. No. 380001
Price/Each \$132.00

HEAVY-DUTY DUAL TEMPERATURE HEAT GUNS

- Increases surface temperature to required working temperature faster than conventional hot air heat guns
- 3-position rocker switch: off, high and low
- Impact resistant heating element
- Support stand enables gun to be stationary for workbench or assembly work



Model No. TF714
Mfg. No. 8975-6
Air volume: 14.8 cu.ft./min.
Air temperatures: 570° F/1000°F
Motor: 120 V AC, 11.6 A
Weight: 1.6 lbs.
Price/Each \$135.00

HEAT GUNS

- Length: 10 1/2"
- Ergonomic style and powerful heating elements
- The variable temperature adjustment allows you to dial in the proper temperature for your job
- Handle Type: Pistol Grip



Model No. TF715
Mfg. No. 8977-20
Air volume: 20 cu.ft./min.
Air temperatures: 100°F - 1040°F (37°C - 560°C)
Motor: 120 V, 11.6 A
Weight: 1.8 lbs.
Price/Each \$189.00

ACCESSORIES



AIR REDUCTION NOZZLE

- Intensified heat in a specific area – soldering

Model No. TF373
Mfg. No. 49-80-0297
Price/Each \$16.50



HOOK NOZZLE

- For surround-bending, soldering pipe or shrinking tubing

Model No. TF370
Mfg. No. 49-80-0292
Price/Each \$16.50



DEFLECTOR

- Deflects air away from glass when stripping paint or softening putty

Model No. TF371
Mfg. No. 49-80-0293
Price/Each \$18.00



AIR SPREADER

- Intensified heat for removing floor coverings, paint burning and vinyl top removal

Model No. TF372
Mfg. No. 49-80-0294
Price/Each \$16.50

ACCESSORY ASSORTMENT

- Includes TF373, TF370, TF371 and TF372

Model No. TF374
Mfg. No. 49-80-0300
Price/Each \$54.90

CORDED POWER TOOLS

HEAVY-DUTY HEAT GUN

- Temperature: 120°F - 1100°F (50°C - 600°C)
- Temperature Setting: Variable
- Voltage: 120 V
- Amps: 13 A
- Wattage: 1550 W
- Power Cord Length: 10'
- Tool Weight: 2.1 lbs.

Model No TLV912
Mfg. No. D26950
Price/Each \$125.00



HEAVY-DUTY LCD HEAT GUN

- Temperature: 150°F - 1100°F (65°C - 600°C)
- Temperature Setting: Variable
- Voltage: 120 V
- Amps: 13 A
- Wattage: 1550 W
- Power Cord Length: 10'
- Tool Weight: 2.3 lbs.

Model No TLV913
Mfg. No. D26960
Price/Each \$165.00



HEAT GUN

- Variable temperature dial provides stepless electronic temperature adjustment to achieve precise heating requirements
- Ergonomic soft rubber grip design for comfortable operation
- Temperature: 122°F - 1022°F (50°C - 550°C)
- Temperature Setting: Variable
- Voltage: 120 V
- Amps: 13 A
- Air Volume - Switch 1: 7.0 CFM (200 l/min)
- Air Volume - Switch 2: 14.0 CFM (400 l/min)
- Includes: Plastic Carrying Case

Model No TYY270
Mfg. No. HG6031VK
Price/Each \$175.00



HEAT GUN

- 2-stage air volume and temperature control provides versatility in a wide range of applications
- Rear housing design with integrated rubber bumpers allows tool to be positioned upright for use as a static heating source during two-handed operations
- Ergonomic soft rubber grip design for comfortable operation
- Temperature: 0°F - 1022°F (0°C - 550°C)
- Temperature Setting: Variable
- Voltage: 120 V
- Amps: 13 A
- Air Volume - Switch 1: 7.0 CFM (200 l/min)
- Air Volume - Switch 2: 14.0 CFM (400 l/min)
- Includes: Plastic Carrying Case (PR00000060)

Model No TYY269
Mfg. No. HG5030K
Price/Each \$115.00



ACCESSORIES



WIDE-ANGLE SLIT NOZZLE
Model No. TD196
Mfg. No. P-71423
Price/Each \$23.90



REFLECTOR NOZZLE
Model No. TD198
Mfg. No. P-71445
Price/Each \$22.90



3/8" REFLECTOR NOZZLE
Model No. TD206
Mfg. No. P-71495
Price/Each \$29.90



AIR REDUCTION NOZZLE
Model No. TD205
Mfg. No. P-71439
Price/Each \$25.90

Maintain the ideal temperature in your workplace

MATRIX
INDUSTRIAL PRODUCTS



1-5/8" ELECTROMAGNETIC DRILL KIT

- Optimized cutting & drilling speeds
- Magnetic deadlift (1") 1800 lbs Auto-Stop function
- Carrying Handle
- Auto-stop lift-off detection
- Tool free feed-handle LED light
- Feed handle can be changed from the left or right side of the tool
- Includes: 1-5/8" Electromagnetic Drill, Lubrication Spray Bottle, 1/2" Chuck Adapter, Chuck Key, (2) 1" Retractable Pilot Pins, Safety Strap & Carrying Case



Model No	TYP028
Mfg. No.	4272-21
Voltage:	13.0
Tension:	120 V
Drill Capacity:	
1-1/2"/1-5/8"	
No Load RPM:	730/475
Drill Point Pressure:	600 lbs.
Stroke Length:	5-3/4"
Tool Weight:	30.0 lbs.
Price/Each	\$1775.00



HEAVY-DUTY SHOP PRESS

- STRONGARM Shop Presses are used in repair shops for the removal and installation of gears, bushings and bearings, as well as with metal bending, straightening, compression and flattening applications
- Features rugged structural steel frame and two arbor plates - Designed for light duty applications
- Eight level bed adjustment
- 12 ton bottle jack with overload protection
- Heavy duty return springs for fast ram retraction
- Comes with 2 V blocks (6" x 6" x 1/2")
- Max. Capacity: 12 Ton(s)
- Bed Depth: 7"
- Distance Between Posts: 16-3/4"
- Weight: 106 lbs.
- Ram Travel: 6-1/4"
- Space Interval: 3-1/2"
- Throat Depth: 3-1/4"
- Throat Width: 14"

Model No. UAV883
Mfg. No. 032161
Price/Each \$649.00



6" BENCH GRINDERS

- Powerful 5/8 HP induction motor for heavy-duty grinding operations
- Motor runs at 3450 RPM for high speed material removal
- Industrial cast iron base and motor housing provide durability and prolong life
- Precision-machined aluminum tool rests allow the user to accurately position work
- Rear exhaust ports in wheel guards for smoother operation
- 12 1/2" distance between wheels for longer and larger grinding applications
- Includes: 36-grit wheel, 60-grit wheel, eye shields, spark deflectors, tool rests, adjusting wrench

Model No.	VE369
Mfg. No	DW756
Amps:	4.0 AC
Horsepower:	5/8 HP
No load speed:	3450 RPM
Wheel dia.:	6"
Spindle dia:	1/2"
Adjustable tool resets:	Yes
Tool length:	15"
Tool weight:	28.5 lbs.
Price/Each	\$229.00



HEAVY-DUTY BENCH GRINDER

- Induction motor provides superior power for industrial grinding applications
- Rugged cast iron base and motor housing provide durability and prolonged life
- Precision-machined aluminum tool rests allow the user to accurately position work
- Rear exhaust ports in wheel guards for smoother operation
- 12-1/2" distance between wheels for larger and longer grinding applications
- Includes: 36 grit wheel, 60 grit wheel, eye shields, spark deflectors, tool rests
- Wheel Diameter: 8"
- HorsePower: 3/4 HP
- No Load Speed: 3600 RPM
- Amps: 4.2 A
- Spindle Diameter: 5/8"
- Tool Length: 16"
- Tool Weight: 39.5 lbs.

Model No. VE370
Mfg. No. DW758
Price/Each \$319.00



BENCH GRINDER

- Heavy-duty for professional use
- Ball bearing drive shafts for reduced vibration
- Features a standard and magnifying eye shield
- Wheel Diameter: 6"
- HorsePower: 1/2 HP
- No Load Speed: 3600 RPM
- Includes: Coarse & Medium Grinding Wheels

Model No. UAV842
Mfg. No. 028016
Price/Each \$199.00



BENCH GRINDER

- Features a cast aluminum base, large flexible worklight (bulb not included), water tray, and a dustproof switch
- Equipped with an adjustable steel workrest
- Wheel Diameter: 8"
- HorsePower: 3/4 HP
- No Load Speed: 3450 RPM
- Wheel Width: 1"
- Arbor Size: 5/8"
- Voltage: 120 V
- Amperage: 3.8 A
- Includes: (1) Standard Safety Glass, (1) Magnifying Safety Glass

Model No. UAV843
Mfg. No. 028017
Price/Each \$265.00



BENCH GRINDING WHEELS

D x T x H: Diameter x Thickness x Hub Size

GEMINI

- Quality, grey aluminum oxide for metal general purpose applications and sharp, green silicon carbide for nonferrous applications
- Each wheel contains nested bushings, accommodates a wide variety of standard arbor sizes
- Economical prices; ideal for small job shops and numerous applications

NORTON



BENCH & PEDESTAL GRINDING WHEELS

- For general purpose grinding work on bench and pedestal grinders
- Grits 24 and 36 for fast and rough grinding
- Grit 46 for intermediate requirements
- Grits 60 and 80 for a finer finish work
- All 6", 7", 8" and 10" wheels are supplied with nested reducer bushings to fit on 1", 3/4" and 1/2" shafts



WALTER
Surface Technologies

Model No.	Mfg. No.	Size			Grade	Max RPM	Price /Each
		D"	x	T"	x	H"	
ALUMINUM OXIDE WHEELS FOR STEEL APPLICATION							
NS320	36132	6	x	1/2	x	1	Coarse 4140 27.00
NS321	36131	6	x	1/2	x	1	Medium 4140 27.00
NS322	36133	6	x	1/2	x	1	Fine 4140 27.00
NS323	37103	6	x	3/4	x	1	Coarse 4140 31.50
NS324	37102	6	x	3/4	x	1	Medium 4140 31.50
NS325	37101	6	x	3/4	x	1	Fine 4140 31.50
NS326	37958	6	x	1	x	1	Coarse 3600 36.50
NS327	37957	6	x	1	x	1	Medium 3600 36.50
NS328	37100	6	x	1	x	1	Fine 3600 36.50
NS329	42292	7	x	1	x	1	Coarse 3600 44.50
NS330	42294	7	x	1	x	1	Medium 3600 44.50
NS331	42295	7	x	1	x	1	Fine 3600 44.50
NS332	42315	8	x	3/4	x	1	Coarse 3600 46.30
NS333	42316	8	x	3/4	x	1	Medium 3600 46.30
NS334	42317	8	x	3/4	x	1	Fine 3600 46.30
NS335	44454	8	x	1	x	1	Very coarse 3600 54.60
NS336	44449	8	x	1	x	1	Coarse 3600 54.60
NS337	44448	8	x	1	x	1	Medium 3600 54.60
NS338	44447	8	x	1	x	1	Fine 3600 54.60
NS339	60788	10	x	1	x	1	Very coarse 2485 86.70
NS340	60787	10	x	1	x	1	Coarse 2485 86.70
NS341	60789	10	x	1	x	1	Medium 2485 86.70
NS342	60350	10	x	1	x	1	Fine 2485 86.70
NS343	61250	10	x	1 1/4	x	1 1/4	Coarse 2485 101.00
NS344	61251	10	x	1 1/4	x	1 1/4	Medium 2485 101.00
NS345	61393	10	x	1 1/2	x	1 1/4	Coarse 2485 120.00
NS346	61395	10	x	1 1/2	x	1 1/4	Medium 2485 120.00
NS347	63052	12	x	1 1/2	x	1 1/2	Coarse 2070 164.00
NS348	63053	12	x	1 1/2	x	1 1/2	Medium 2070 164.00
NS349	63054	12	x	2	x	1 1/2	Very coarse 2070 214.00
NS350	63055	12	x	2	x	1 1/2	Coarse 2070 214.00
NS351	63056	12	x	2	x	1 1/2	Medium 2070 214.00

Model No.	Mfg. No.	Size			Grit	Max RPM	Price /Each
		D"	x	T"	x	H"	
VE777	12-E-344	6	x	1	x	1	36 Coarse 4100 51.90
VE778	12-E-345	6	x	1	x	1	46 Medium 4100 51.90
VE779	12-E-348	6	x	1	x	1	80 Fine 4100 51.90
VE785	12-E-543	8	x	1	x	1	24 Coarse 3600 77.80
VE786	12-E-545	8	x	1	x	1	46 Medium 3600 77.80
VE787	12-E-547	8	x	1	x	1	60 Fine 3600 77.80

SCOTCH-BRITE™ EXL DEBURRING WHEELS

Use to clean, finish, blend, deburr or polish all types of metals, composites and glass.



3M

Model No.	Grit	Finish	Size"			Max. RPM	Price /Each	
			D"	x	T"	x	H"	
BP694	8A	Medium	6	x	1/2	x	1	6000 94.49
BP695	8S	Fine	6	x	1/2	x	1	6000 94.50
BP696	9S	Fine	6	x	1/2	x	1	6000 94.50
BP690	8A	Medium	6	x	1	x	1	6000 125.30
BP692	8S	Fine	6	x	1	x	1	6000 125.30
BP693	9S	Fine	6	x	1	x	1	6000 125.30
BP701	8A	Medium	8	x	1/2	x	3	4500 119.78
BP697	8A	Medium	8	x	1	x	3	4500 160.16
BP698	8S	Fine	8	x	1	x	3	4500 160.16
BP700	9S	Fine	8	x	1	x	3	4500 160.16

CRIMPED WIRE WHEEL BRUSHES

- Can be mounted horizontally or vertically
- Highly flexible, ideal for light to medium duty surface preparation on irregular surface
- Offered a variety of style from aggressive material removal to surface conditioning and polishing

OSBORN
JACKSONLEA

NARROW FACE

- More flexible than the wide and medium style
- Can be mounted in multiples
- To be used with a straight grinder, a bench/pedestal grinder or a right angle grinder
- Application:** Deburring and cleaning narrow areas, producing antique finishes, rust and paint removal



Brush Dia."	Arbor Hole"	Wire Gauge"	Trim Length"	Face Width"	Max RPM	Model No.	Price /Each
STEEL							
6	1 1/4	0.0104	1 1/8	5/8	6000	BW882	33.90
8	1 1/4	0.014	1 1/2	5/8	4500	BW886	46.90
10	1 1/4	0.014	2 1/2	5/8	3600	BW888	60.90
STAINLESS							
6	1 1/4	0.0104	1 1/8	5/8	6000	BW899	68.90
8	1 1/4	0.0104	3/4	1/2	4500	BW900	83.50

SEE PAGES 876-881 FOR A WIDE VARIETY OF WIRE WHEEL BRUSHES

MEDIUM FACE

- Greater fill density and more aggressive brushing action
- Can be adaptable to multiple mounting for brushing wider areas
- To be used with a bench/pedestal grinder
- Application:** Edge blending, deburring, rust removal, surface finishing and cleaning



Brush Dia."	Arbor Hole"	Wire Gauge"	Trim Length"	Face Width"	Max RPM	Model No.	Price /Each
STEEL							
6	2	0.0118	1	7/8	6000	BW996	54.90
8	2	0.0118	1 1/2	5/8	4500	BX006	77.90
10	2	0.0118	2	1 1/4	3600	BX022	129.00
STAINLESS							
8	2	0.0118	1 1/2	5/8	4500	BX038	129.00

CORDED POWER TOOLS



RANDOM ORBIT PALM SANDERS

- Fast random-orbit action for aggressive sanding
- Efficient through the pad dust collection system
- High power motor for heavy duty application
- Includes: 5" abrasive disc, dust bag and pad

Model No. TLY383
Mfg. No. BO5030
Price/Each \$169.00

SPECIFICATIONS

Sandpaper Size: 5"
Voltage: 120 V
Amperage: 3.0
Orbits per Minute: 12000
Orbit Diameter: 1/8"
Tool Weight: 2.9 lbs.



SHEET PALM SANDERS

- Dust bag for clean and efficient sanding with extended sandpaper life by reducing clogging
- All ball bearing construction for smooth operation, engineered to operate at low noise level with reduced vibration
- Comes with easy to use clamp lever and hook and loop pad
- Includes: Dust bag, nozzle, dust nozzle, punch plate, three sanding paper and plastic case

Model No. TLY382
Mfg. No. BO4555K
Price/Each \$145.00

SPECIFICATIONS

Sandpaper Size: 1/4 sheet
Voltage: 120 V
Amperage: 2.0
Orbits per Minute: 14000
Tool Weight: 2.4 lbs.



HEAVY DUTY 3" X 24" BELT SANDER

- All ball and needle bearing construction
- Fast sandpaper changes with lever clamps
- Includes: Dust bag and 10-pack of abrasive belts

Model No. TF795
Mfg. No. 9924DB
Price/Each \$389.00

SPECIFICATIONS

Belt Size: 3" W x 24" L
Voltage: 120 V
Amperage: 7.8
Surface Feet per Minute: 1300
Tool Weight: 10.5 lbs.



RANDOM ORBIT PALM SANDERS

- Variable speed dial: 7000-12000 orbits per minute
- Electronic soft start quickly and steadily ramps the motor up in stages
- Integrated vacuum ports fits 1 1/4" or 2 1/4" hoses
- Includes: Dust bag and carrying case

Model No. TLZ441
Mfg. No. 6021-21
Price/Each \$119.00

SPECIFICATIONS

Sandpaper Size: 5"
Voltage: 120 V
Amperage: 3.0
Orbits per Minute: 7000-12000
Orbit Diameter: 3/32"
Tool Weight: 3.3 lbs.



SHEET FINISHING SANDER

- Powerful motor features increased power input and increased cooling for demanding sanding applications
- Redesigned housing reduces height creating a lower centre of gravity to improve handling and maneuverability
- Large clamping Lever for quick and easy sandpaper changes
- Rigid aluminum foot with sponge sleeves for durability and effective vibration dampening
- Ergonomic soft rubber grip design for vibration absorption and comfortable operation
- Pad Size: 3-5/8"W x 7-1/4"D
- Overall Length: 10"
- Includes: Dust bad, Punch plate, pad

Model No. TDU674
Mfg. No. BO3710
Price/Each \$139.00

SPECIFICATIONS

Sandpaper Size: 1/3 sheet
Voltage: 120 V
Amperage: 1.7
Orbits per Minute: 11000
Tool Weight: 3.5 lbs.



SINGLE SPEED RANDOM ORBIT SANDER

- Shorter height allows the user to get closer to work piece
- Separate counterweight design reduces vibration for improved comfort
- Rubber overmold in all of the critical areas of the sander
- Improved dust-sealed switch to protect against dust ingestion for longer switch life
- Improved dust collection and one-handed locking dust bag
- Dust port is designed to fit directly to the DWV010 or DWV012 dust collectors
- To attach dust port to other vacuum systems with 1-1/4" hoses, use DWV9000 Universal Quick Connector

Model No. NKD609
Mfg. No. DWE6421
Price/Each \$129.00

SPECIFICATIONS

Sand Paper Size: 5"
Voltage: 120 V
Amps: 3 A
Orbits per Minute: 12000
Orbit Diameter: 3/32"
Pad Type: Hook & Loop
Tool Height: 140 mm
Tool Weight: 2.9 lbs.



3/8" HEAVY-DUTY COMPOSITE AIR IMPACT WRENCHES

- Lightweight composite design minimizes operator fatigue
- Ergonomic grip reduces vibration
- Exhaust air outlet directs air away from operator
- Forward-reverse switch, and high-low speed regulator
- Low noise, low vibration
- Overall length: 7"
- Weight: 2.8 lbs.

Model No. TLZ137



AURORA
TOOLS

1/2" HEAVY-DUTY COMPOSITE AIR IMPACT WRENCHES

- Lightweight composite design minimizes operator fatigue
- Ergonomic grip reduces vibration
- Exhaust air outlet directs air away from operator
- Forward-reverse switch, and high-low speed regulator
- Low noise, low vibration
- Overall length: 7 3/4"
- Weight: 4.6 lbs.

Model No. TLZ138



AURORA
TOOLS

Model No.	Square Drive in mm	Bolt Capacity in mm	Free Speed RPM	Torque Range ft.-lbs.	Average Air Consumption CFM	Air Inlet	Hose Size in mm	Vibrations Less Than m/s ²	Sound Pressure Level dB(A)	Price /Each
TLZ137	3/8 9.53	1/2 13	10000	90-280	10.6	1/4"-18 NPT	3/8 9.5	3.7	91.5	331.00
TLZ138	1/2 12.7	5/8 16	10000	400-1000	13.7	1/4"-18 NPT	3/8 9.5	6.0	94	399.00

COMPOSITE 3/4" HEAVY-DUTY AIR IMPACT WRENCHES

- Lightweight composite design minimizes operator fatigue
- Ergonomic grip reduces vibration
- Exhaust air outlet directs air away from operator
- Forward-reverse switch, and high-low speed regulator
- Overall length: 8"
- Weight: 5 lbs.



AURORA
TOOLS

Model No.	Square Drive in mm	Bolt Capacity in mm	Free Speed RPM	Torque Range ft.-lbs.	Average Air Consumption CFM	Air Inlet	Hose Size in mm	Vibrations Less Than m/s ²	Sound Pressure Level dB(A)	Price /Each
TLZ139	3/4 19.1	1 26	9000	450-1000	13.7	1/4"-18 NPT	3/8 9.5	9.2	95.9	576.00

3/4" HEAVY-DUTY AIR IMPACT WRENCHES

- Twin hammer impact mechanism
- Three-step forward/reverse regulator allows the operator to adjust the power to the job
- Rear exhaust directs air away from work piece and operator
- Ergonomically designed to reduce operator fatigue
- Special heat-treatment of major parts and anvil for long life
- Soft rubber grip handle reduces fatigue
- Weight: 11 lbs.

Model No. THZ672



AURORA
TOOLS

1/2" HEAVY-DUTY AIR IMPACT WRENCH

- Pin-clutch hammer mechanism
- Built-in regulator to prevent over-torquing
- Low noise, low vibration
- Forward-reverse switch, and high-low speed regulator
- Durability and longer life
- Weight: 5 lbs.

Model No. UAK133



AURORA
TOOLS

Model No.	Square Drive in mm	Bolt Capacity in mm	Free Speed RPM	Torque Range ft.-lbs.	Average Air Consumption CFM	Air Inlet	Hose Size in mm	Vibrations Less Than m/s ²	Sound Pressure Level dB(A)	Price /Each
THZ672	3/4 19	1 25.4	4600	565-1100	9	1/4"-18 NPT	3/8 9.5	6.1	90	506.00
UAK133	1/2 12.7	5/8 15.9	7000	25-320	12	1/4"-18 NPT	3/8 9.5	3.1	94	205.00

AIR TOOLS



2115TIMAX IMPACT WRENCH

- Titanium hammer case and composite housing
- 7-vane motor delivers added power with less weight
- Finely tuned twin hammer impact mechanism and motor deliver more torque, durability, and efficiency
- Feather-touch trigger provides maximum control
- Max. Torque in Reverse: 300 ft-lbs.
- Drive Type: Square Hog-Ring



Model No.	Mfg. No.	Air Consumption	Air Inlet	Sound Level (dBA)	Drive"	No Load RPM	Price /Each
BW352	2115TIMAX	4 CFM	1/4" NPTF	107.6	3/8	15000	444.00

ULTRA-COMPACT AIR IMPACT WRENCH

- Stubby 4.6" length and compact design gives you total control to get up, under, over, or around any tough job
- One-handed forward/reverse push button and 3-mode power regulator give you maximum control
- Drive Type: Square, Hog-Ring
- Nut-Busting Torque: 475 ft-lbs
- Blows Per Minute: 1350



Model No.	Mfg. No.	Air Consumption	Air Inlet	Sound Level (dBA)	Drive"	No Load RPM	Price /Each
UAI480	15QMAX	17 CFM	1/4" NPTF	89.7	3/8	6000	295.00

2235TIMAX IMPACT WRENCH

- The high torque output of the powerful vane motor is optimized to increase safety and control over the tool
- Titanium hammer case is designed to be strong and durable
- Features patented quiet tool technology reducing sound levels
- Max. Torque in Reverse: 930 ft-lbs.
- Drive Type: Square Hog-Ring



Model No.	Mfg. No.	Air Consumption	Air Inlet	Sound Level (dBA)	Drive"	No Load RPM	Price /Each
NKD054	2235TIMAX	6 CFM	1/4" NPTF	109	1/2	8500	627.00

2135QXPA IMPACT WRENCH

- Light, quiet, and powerful design
- Drive Type: Square
- Max. Torque in Reverse: 780 ft-lbs.
- Torque (Forward): 700 ft-lbs.
- Torque (Reverse): 780 ft-lbs.



Model No.	Mfg. No.	Air Consumption	Air Inlet	Sound Level (dBA)	Drive"	No Load RPM	Price /Each
UAE021	2135QXPA	5 CFM	1/4" NPTF	90.7	1/2	11000	473.00

2145QIMAX IMPACT WRENCH

- Titanium hammer case is designed to be strong and durable
- Finely tuned twin hammer impact mechanism and motor deliver more torque, durability, and efficiency
- Feather-touch trigger provides maximum control
- Max. Torque in Reverse: 1350 ft-lbs.
- Drive Type: Square Hog-Ring and Thru-Hole



Model No.	Mfg. No.	Air Consumption	Air Inlet	Sound Level (dBA)	Drive"	No Load RPM	Price /Each
NJT321	2145QIMAX	8.5 CFM	3/8" NPT	107.3	3/4	7000	999.00

2925 SERIES IMPACT WRENCH

- Bronze endplates and a corrosion preventative treatment prevents internal rust in outdoor, wet environments
- Choice of reverse bias or non-biased motors gives you solutions for both removing or fastening bolts
- Pressure-fed mechanism lubrication ensures complete coverage throughout the tool
- Weight: 12.2 lbs.
- Length: 9"
- Configuration: Pistol
- Free Speed Sound Level Pressure: 99.6



Model No.	Mfg. No.	Air Consumption	Air Inlet	Sound Level (dBA)	Drive"	No Load RPM	Price /Each
UAE347	2925RBP3TI	60	3/8" NPT	110.6	1	5200	3862.00

3900 SERIES IMPACT WRENCHES

- Thanks to the bronze end-plate and a corrosion preventative treatment, this series is corrosion and wear resistant, making it great for outdoor conditions
- The titanium hammer case and metal housing means this tool can withstand even the harshest conditions
- Twin hammer mechanism ensure consistent power and balance



UAE353



UAE350



Model No.	Mfg. No.	Air Consumption	Air Inlet	Sound Level (dBA)	Drive"	No Load RPM	Forward Torque	Blows Per Minute	Weight lbs.	Length"	Price /Each
UAE350	3940B2TI	64	1/2" NPT	114.4	1"	6000	1650 ft-lbs.	800	21.2	13.5	7014.00
UAE353	3955B2TI	80	1/2" NPT	112.5	1-1/2"	2750	3900 ft-lbs.	700	34.6	16.5	8114.00

3/8" IMPACT WRENCHES

For general maintenance

- Twin hammer clutch
- Composite handle and magnesium clutch housing
- S2S technology allows to effortless change between forward and reverse
- Three positive power settings
- Full teasing trigger

Model No. TLV696



3/8" BUTTERFLY IMPACT WRENCHES

- Butterfly forward/reverse throttle
- Rocking dog clutch for smooth operations and durability
- Four positive power settings
- Easy maneuvering with 360° air inlet swivel
- Comfort and maneuverability
- Shank size: 3/8"
- Shank retainer type: Friction ring
- Working torque: 5-65 ft-lbs.
- Ideal for bench work, carburetors, ignitions, body panels, transmissions, oil pans and small engine repair

Model No. THZ806



1/2" IMPACT WRENCHES

For general duty repair/maintenance and light-to-medium assembly applications.

- Twin clutch increases ultimate torque for smooth operation under heavy loading
- Oil bath clutch
- Teasing throttle

Model No. THZ948



1/2" IMPACT WRENCHES

Standard duty for use in a variety of fastening operations.

- Dyna Pact™ clutch
- Built-in power regulator
- Push-through reverse mechanism

Model No. THZ946



1" IMPACT WRENCHES

Standard duty for use in steel erection, heavy assembly/disassembly, maintenance/repair, and construction.

- Teasing throttle
- Rocking dog clutch
- Closed-grip inside trigger
- 6" extended shank
- 1/2" (NPTF) air inlet thread
- 1/2" min. hose size

Model No. TJZ370



3/4" IMPACT WRENCHES

High ultimate torque for tough applications.

- Ideal for hard pull up conditions
- Push-through reverse mechanism
- Teasing throttle
- Oil bath clutch chamber
- Pin clutch
- 3/8" (NPTF) air inlet thread
- 3/8" min. hose size

Model No. THZ955



Model No.	Mfg. No.	Size		Shank Retainer Type	Working Torque		Maximum Torque		CFM	Overall Length		Net Weight		Price /Each
		in.	mm		ft-lbs.	Nm	ft-lbs.	Nm		in.	mm	lbs.	kg	
TLV696	CP7722	3/8	10	Friction Ring	50-300	68-407	415	563	20	6 1/2	163	2.8	1.3	426.00
THZ806	CP772	3/8	10	Friction Ring	5-50	6.8-70	90	122	10	5 3/4	146	2	0.9	314.00
THZ946	CP734H	1/2	13	Friction Ring	25-310	34-420	425	576	15	7 1/2	191	5	2.3	359.00
THZ948	CP749	1/2	13	Friction Ring	25-330	34-450	450	610	16	7 1/2	194	5.5	2.5	473.00
THZ955	CP772H	3/4	19	Friction Ring	150-700	200-950	1000	1360	24	9 5/8	244	10.5	4.8	889.00
TJZ370	CP797	1	25.4	Hole for Socket Pin	150-900	200-1225	1400	1900	40	15 1/2	394	27	12.3	1747.00

Noise levels are at 1.0 m per Pneurop Standard 8N-1. Vibration levels are per ISO 8662-1.

Standard equipment: removable dead handle. **TG063:** Socket pin and retaining ring. **TG065:** adjustable and removable dead handle, socket pin and retaining ring.

AIR TOOLS



COMPACT IMPACT WRENCH

- Weighing only 2.9 lb., this lightweight impact wrench helps eliminate user fatigue
- Made from lightweight and durable aluminum, the impact- and chemical-resistant housing protects against repeated drops and exposure to shop fluids
- This compact and lightweight impact wrench delivers exceptional power and performance
- The jumbo hammer mechanism provides more powerful and balanced impact blows for reduced vibration
- The one-handed operation, Forward-Reverse by either left- or right-handed users makes the wrench strong, durable, and convenient to use
- Socket Size: 1/2"
- Torque: 450 ft-lbs.
- No Load RPM: 10000
- Average Air Consumption: 4.5 CFM
- Air Inlet: 1/4" NPT
- Sound Pressure: 93.9 dBA

Model No. UAV930
Mfg. No. 400268
Price/Each \$294.00



SUPER HEAVY-DUTY IMPACT WRENCH

- With an ultra-compact design for confined workspaces, these super heavy-duty impact wrenches produce 1100 ft-lb of max torque in reverse
- The twin hammer mechanism reduces vibration and increases durability
- Made from lightweight and durable aluminum, the impact- and chemical-resistant housing protects against repeated drops and exposure to shop fluids
- Weighing only 4.4 lb., these 1/2" Drive Air Impact Wrench has a lightweight and balanced design
- Socket Size: 1/2"
- Torque: 715 ft-lbs.
- No Load RPM: 6500
- Average Air Consumption: 5.3 CFM
- Air Inlet: 1/4" NPT
- Sound Pressure: 95.2 dBA

Model No. UAV931
Mfg. No. 400280
Price/Each \$378.00



HEAVY-DUTY AIR IMPACT WRENCH

- With an ultra-compact design for confined workspaces, these impact wrenches produce 650 ft-lb of max torque in reverse
- The twin hammer mechanism reduces vibration and increases durability
- Made from lightweight and durable aluminum, the impact- and chemical-resistant housing protects against repeated drops and exposure to shop fluids
- The highly durable all-steel motor provides ultimate life and performance
- Weighing only 4.4 lb., the 1/2" Drive Air Impact Wrench has a lightweight and balanced design
- Socket Size: 1/2"
- Torque: 590 ft-lbs.
- No Load RPM: 6200
- Average Air Consumption: 5.6 CFM
- Air Inlet: 1/4" NPT
- Sound Pressure: 91.7 dBA

Model No. UAV929
Mfg. No. 400260
Price/Each \$331.00



VARIABLE SPEED AIR DRILL

- Double-reduction planetary gear system gives low speed and high torque for heavier drilling jobs
- Variable-speed dial and feather trigger allows the user to select the appropriate drilling speed for their application
- Thermoplastic rubber over-molded handle grip for increased comfort
- Industrial-grade all-metal keyed chuck for increased durability
- Designed for heavy-duty drilling applications
- Air Consumption: 6 CFM
- Air Inlet: 1/4" NPT
- Sound Level (dBA): 82
- Chuck Type: Keyed
- HP: 0.5
- Spindle Size: 3/8"-24
- **UAV947:** Includes 360-degree side handle



UAV947

Model No.	Mfg. No.	Chuck Size"	Fan Speed RPM	Max. Torque	Price /Each
UAV946	404433	3/8	2000	12 ft-lbs.	216.00
UAV947	404443	1/2	600	18 ft-lbs.	337.00

3/8" AIR REVERSIBLE DRILLS

- Lightweight composite design minimizes operator fatigue
- Ergonomic grip reduces vibration
- Two-gear structure runs smoothly
- Power: 0.5 HP

Model No. THZ675



AURORA
 TOOLS

1/2" AIR REVERSIBLE DRILLS

- Lightweight composite design minimizes operator fatigue
- Ergonomic grip reduces vibration
- Two-gear structure runs smoothly
- Side handle included
- Power: 0.5 HP

Model No. THZ676



AURORA
 TOOLS

Model No.	Chuck Size in mm	Spindle Thread	Free Speed RPM	Average Air Consumption CFM	Air Inlet	Hose Size in mm	Vibration Less Than m/s ²	Sound Pressure Level dB(A)	Net Weight lbs. kg	Price /Each
THZ675	3/8 9.5	3/8" - 24 threads	1800	4	1/4" - 18 NPT	3/8 9.5	0.10	88	2.0 0.91	130.00
THZ676	1/2 12.7	3/8" - 24 threads	450	4	1/4" - 18 NPT	3/8 9.5	0.15	88	3.0 1.36	168.00

3/8" HEAVY-DUTY AIR RATCHET WRENCHES

- Lightweight aluminum design minimizes operator fatigue
- Polyurethane grip reduces vibration
- Variable speed, reversible
- Paddle style trigger provides better speed control
- Ideal for automotive and industrial fastener removal and installation work

Model No. THZ671



AURORA
TOOLS

1/2" HEAVY-DUTY AIR RATCHET WRENCHES

- Lightweight aluminum design minimizes operator fatigue
- Polyurethane grip reduces vibration
- Variable speed, reversible
- Paddle style trigger provides better speed control
- Ideal for automotive and industrial fastener removal and installation work

Model No. THZ680



AURORA
TOOLS

Model No.	Square Drive Size		Free Speed RPM	Torque Range ft.-lbs.	Average Air Consumption CFM	Air Inlet	Hose Size		Horse Power HP	Vibration Less Than m/s ²	Sound Pressure Level dB(A)	Net Weight		Price /Each
	in	mm					in	mm				lbs.	kg	
THZ671	3/8	9.5	175	5-75	3	1/4" - 18 NPT	3/8	9.5	0.45	1.0	78	2.6	1.18	120.00
THZ680	1/2	12.7	175	5-75	3	1/4" - 18 NPT	3/8	9.5	0.45	1.0	83	2.6	1.18	119.00

STUBBY INDUSTRIAL AIR RATCHET WRENCH

- Air Consumption: 3 CFM
- Air Inlet: 1/4" NPT
- Sound Level (dBA): 96
- Drive: 1/4"
- No Load RPM: 270
- Torque Range: 5 - 25 ft.lbs.
- Hose Diameter: 5/16"
- Vibration Less Than: 1.4 m/s²
- Overall Length: 6-1/2"

Model No. UAV712
Price/Each \$135.00



AURORA
TOOLS

HEAVY-DUTY MINI RATCHET WRENCH

- Slim profile head ideal for engine compartment and under-dash work
- Contoured composite housing cover with traction pad for maximum operator comfort and control
- Fully recessed throttle for easy grip
- Roll forged pawl is specially heated to limit spreading and extend service life
- Air Consumption: 2.55 CFM
- Air Inlet: 1/4" NPT
- Sound Level (dBA): 89
- Drive: 1/4"
- No Load RPM: 250
- Maximum Torque: 25 ft.lbs.
- Overall Length: 6-3/4"
- Standard Bolt Capacity: 3/8"
- Vibration: 2.32 m/s²

Model No. UAV820
Mfg. No. RW25HDM
Price/Each \$14999.00



KLETON

**CANADA'S LEADING
MATERIAL HANDLING
SUPPLIER**





1/4" AIR SCREWDRIVERS

- Durable steel body
- Forward-reverse switch
- Low noise, low vibrations
- Overall length: 7 1/2"
- Weight: 2.4 lbs.



Model No.	TLV495
Air Consumption	6 CFM
Air Inlet:	1/4"-18 NPT
Sound Level (dBA)	82
No Load RPM	1800
Torque Range ft.-lbs.	3.75-9.5
Hose Size	3/8" (9.5 mm)
Horse Power	0.5
Vibrations Less than m/s²	0.7
Price/Each	\$157.00

AURORA
TOOLS

DIRECT DRIVE REVERSIBLE SCREWDRIVER



Model No.	UAG274
Mfg. No.	GS-1017Q
Clutch Type	Keyless / Direct Drive Reversible
Handle style	Pistol grip
Operation	Trigger start
Torque range	216-312 in.-lbs.
Length	5.6" (142 mm)
Weight	1.98 lbs (0.9 kg)
Air Consumption	28 CFM
Air Inlet	1/4" NPTF
Air Hose Bore	3/8"
Sound Level (dBA)	88
Vibration Level	<2.5 m/s ²
Price/Each	\$220.00

AURORA
TOOLS

DIRECT DRIVE REVERSIBLE SCREWDRIVERS

- Suitable for variable torque
- High speed fast screw rundown
- Ergonomic pistol grip improves operator comfort and productivity

Model No.	TLZ339
Mfg. No.	CP2755
Clutch Type	Direct drive reversible
Handle style	Pistol grip
Operation	Trigger start
Free Speed	2200 RPM
Output	Hex. 1/4"
Torque range	124 in.-lbs.
Length	6.3"
Weight	2.27 lbs.
Air Flow	29 CFM
Air Inlet	1/4" NPTF
Air Hose Bore	3/8"
Sound Level	90 dBA
Vibration Level	<2.5 m/s ²
Price/Each	\$355.00



 **Chicago Pneumatic™**

POSITIVE CLUTCH REVERSIBLE SCREWDRIVERS

- Quick change chuck
- Operator can force clutch engagement for higher torque
- Reverse control at the trigger
- Good for prevailing torque applications
- High speed and high torque

Model No.	TLZ340
Mfg. No.	CP2780
Clutch Type	Positive clutch
Handle style	Pistol grip
Operation	Trigger start
Free Speed	2100 RPM
Output	Hex. 1/4"
Torque range	133 in.-lbs.
Length	6.46"
Weight	2.35 lbs.
Air Flow	29 CFM
Air Inlet	1/4 NPTF
Air Hose Bore	3/8"
Sound Level	89 dBA
Vibration Level	26.8 m/s ²
Price/Each	\$440.00



 **Chicago Pneumatic™**

19 SERIES - STALL SCREWDRIVERS

- Tool weight: 1.16 lbs.
- Tool length: 5.9"
- Free speed: 1100 RPM
- Max Torque: 40 in.-lbs.
- Engineered for heavy duty applications in the most demanding environment
- Adjustable reverse lever for true one-hand - left-handed or right-handed - operation
- Trigger start
- "P" handle style
- Interchangeable soft-touch grip sizes
- Air consumption: 11 CFM
- Air inlet: 1/4"
- Sound level (dBA): 80
- Chuck Size: 1/4"
- Chuck Type: Keyless

Model No. TYN249
Mfg. No. 19PTS04Q
Price/Each \$1735.00



Cleco®

19 SERIES - PISTOL GRIP SCREWDRIVERS W/ADJUSTABLE TORQUE SETTINGS

- Tool weight: 1.41 lbs.
- Tool length: 8.0"
- Free speed: 1100 RPM
- Max Torque: 40 in.-lbs.
- Engineered for heavy duty applications in the most demanding environment
- Class-leading accuracy and repeatability
- Adjustable reverse lever for true one-hand - left-handed or right-handed - operation
- "P" handle style
- Interchangeable soft-touch grip sizes
- Trigger and Push & Trigger start
- External torque adjustment from 10 - 40 in.-lbs.
- Air consumption: 11 CFM
- Air inlet: 1/4"
- Sound level (dBA): 80
- Chuck Size: 1/4"
- Chuck Type: Keyless

Model No. TYN248
Mfg. No. 19PTA04Q
Price/Each \$2479.00



Cleco®

1/4" PNEUMATIC MINI DIE GRINDERS

- Polyurethane grip reduces operator fatigue and vibration
- Power/speed regulator allows for easy PSI adjustment
- Twin-bearing design for smooth operation
- Wrenches included

Model No. THZ678



1/4" PNEUMATIC ANGLE DIE GRINDERS

- Polyurethane grip reduces operator fatigue and vibration
- Power/speed regulator allows for easy PSI adjustment
- Twin-bearing design for smooth operation
- Wrenches included

Model No. THZ679



AURORA
TOOLS

AURORA
TOOLS

Model No.	Collet Size in mm	Free Speed RPM	Average Air Consumption CFM	Air Inlet	Hose Size in mm	Horsepower HP	Vibration Less Than m/s ²	Sound Pressure Level dB(A)	Net Weight lbs. kg	Price /Each
THZ678	1/4 6.4	25000	3	1/4" - 18 NPT	3/8 9.5	0.35	0.1	83	0.9 0.43	80.35
THZ679	1/4 6.4	18000	3	1/4" - 18 NPT	3/8 9.5	0.45	0.1	80	1.7 0.77	98.30

INDUSTRIAL DIE GRINDERS

- Excellent ergonomics
- Very low maintenance
- Low vibration
- Built for continuous use



Chicago Pneumatic™

Model No.	Mfg. No.	Free Speed RPM	Collet Max Capacity"	Power HP	Power W	Weight lbs. kg	Air Consumption		Air Inlet Thread"	Hose I.D."	Price /Each			
							At Free Speed CFM	At Max Output L/s						
TCW168	CP3451-18SEC	18000	1/4	1.0	750	3.1	1.4	14	6.7	17	8	1/4	5/16	843.00
TCW258	CP3000-424R	24000	1/4	0.5	400	1.8	0.84	27	13	25	12	1/4	5/16	547.00
TCW144	CP3030-420R	13000	1/4	0.8	600	2.6	1.3	21	10	40	19	3/8	3/8	609.00
TCW044	CP3109-13AC	13000	1/4	0.8	600	2.4	1.1	21	10	32	15	3/8	3/8	1386.00
TCW088	CP3109-24ES	24000	1/4	0.8	600	2.9	1.3	21	10	32	15	3/8	3/8	1332.00
TCW174	CP3109-24	24000	1/4	0.8	600	2.0	0.9	21	10	32	15	3/8	3/8	1025.00

GRINDERS

MINI ANGLE DIE GRINDERS

For high-speed blending, smoothing, porting and deburring in confined areas.

- Compact, lightweight design
- Lock-off throttle
- 90° angle head
- Front exhaust
- 1/4" (NPTF) air inlet thread
- 3/8" min. hose size

Model No. TG077



DIE GRINDERS & EXTENDED SPINDLE DIE GRINDERS

For die contouring and repair, weld cleaning, casting and forging cleanup, deburring, blending, and smoothing.

- 1/2 HP motor
- Square handle design
- Lock-off throttle
- Rear exhaust
- TG079 - 6" extended spindle
- 1/4" (NPTF) air inlet thread
- 3/8" min. hose size

Model No. TG078, TG079



MINI DIE GRINDERS

For high-speed blending, smoothing, porting and deburring in confined areas.

- Compact, lightweight design
- Lock-off throttle
- Front exhaust
- 1/4" (NPTF) air inlet thread
- 3/8" min. hose size

Model No. TG076



Chicago Pneumatic™

Model No.	Mfg. No.	Collet Size		Spindle Thread"	Free Speed RPM	CFM	dBA	Vibration m/s ²	Overall Length		Net Weight		Price /Each
		in.	mm						in.	mm	lbs.	kg	
TG076	CP876	1/4	6	3/8"-24	28000	16	101	2.5	4 3/4	119	3/4	0.3	136.00
TG077	CP875	1/4	6	3/8"-24	21000	16	101	2.5	4 7/8	123	1	0.5	140.00
TG078	CP860	1/4	6	M10 x 1.25"	24000	20	90	3.0	5 3/4	146	1 1/4	0.6	275.00
TG079	CP860ES	1/4	6	M10 x 1.25"	24000	20	90	3.0	11 3/4	298	2 1/10	0.95	510.00

Noise levels are at 1.0 m per Pneuport Standard 8N-1. Vibration levels are per ISO 8662-1.



HEAVY-DUTY ANGLE GRINDER

- For maximum performance we recommend 90 PSI air pressure
- Hardworking, compact .7 horsepower grinder designed for professional use
- Spindle lock for easy accessory changes
- Adjustable swivel guard has 9 positive lock settings, no tools require
- Composite housing and insulated side handle for operator comfort and control
- Rear exhaust directs air away from workplace
- Low noise, only 83 dBA
- Safety toggle on throttle lever prevents accidental start-ups
- Spindle backing plate and wheel nut suitable for use on all cut-off (T1) and grinding (T27) wheels up to 1/4" thickness
- Wheel Diameter: 5"
- No Load RPM: 11000
- Air Inlet: 1/4"
- Air Consumption: 4 CFM
- Min. Hose Size: 3/8"

Model No. UAV941
Mfg. No. 402313
Price/Each \$632.00



2-IN-1 DIE GRINDER COMBO SET

- Quality advances for longer service life include: steel end plate inserts, brass collar, reinforced air inlet and cylinder made of higher quality steel
- Mini length housing for use in confined areas
- All ball bearing construction and lever throttle with roller for positive speed control
- Self-locking throttle lever prevents accidental starting of motor
- Built-in air regulator
- Collet Size: 1/4"
- Max. RPM: 25 000
- Air Inlet: 1/4"
- Min. Hose Size: 3/8"
- Sound Pressure: 90 dBA/103 dBA
- Air Consumption: 4 CFM/5 CFM
- Includes: (1) 402109 - .3 HP 1/4" Mini Die Grinder - Standard Duty, (1) 402110 - .3 HP 1/4" Mini 90° Angle Head Die Grinder - Standard Duty

Model No. UAV935
Mfg. No. 402149
Price/Each \$252.00



90° ANGLE HEAD DIE GRINDER

- Convenient, comfortable pistol grip design provides great operator control
- Compact overall length, perfect for working in tight areas
- Direct drive mechanism has fewer moving parts, for maximum tool life
- Ergonomic handle with finger grips and insulating cover
- Variable speed push button throttle
- Muffled handle exhaust directs air away from work piece
- Collet Size: 1/4"
- No Load RPM: 18 000
- Air Consumption: 4 CFM
- Min. Hose Size: 3/8"
- Sound Pressure: 86 dBA

Model No. UAV933
Mfg. No. 402120
Price/Each \$184.00



2-IN-1 MINI AIR DIE GRINDER COMBO

- Ball bearing construction for maximum tool life and durability
- Lever throttle for positive speed control
- Built in regulator
- Front exhaust
- Collet Size: 1/4"
- Max. RPM: 25 000
- Air Consumption: 4 CFM
- Air Inlet: 1/4"
- Sound Pressure: 86 dBA/84 dBA
- Includes: (1) 90° Mini Die Grinder (402009), (1) Straight Mini Die Grinder (402010)

Model No. UAV934
Mfg. No. 402148
Price/Each \$164.00



90° QUIET SERIES DIE GRINDER

- Powerful .6HP motor for heavy-duty cutting/grinding applications
- Low noise level (84dBA) for operator comfort
- Front and back ball bearings and motor end plates for increased life and durability
- Lever throttle with roller tip for easy operation
- Cushion grip reduces vibration and user fatigue
- Air inlet screens filter air line debris, extending motor life
- Ideal for most heavy-duty industrial applications
- Collet Size: 1/4"
- No Load RPM: 12 500
- Air Inlet: 1/4"
- Air Consumption: 5 CFM
- Sound Pressure: 84 dBA

Model No. UAV937
Mfg. No. 402213
Price/Each \$413.00



EXTENDED SHAFT QUIET SERIES DIE GRINDER

- Powerful .6 HP motor for heavy-duty cutting/grinding applications
- Low noise level (84 dBA) for operator comfort
- Front and back ball bearings and motor end plates for increased life and durability
- Lever throttle with roller tip for easy operation
- Cushion grip reduces vibration and user fatigue
- Air inlet screens filter air line debris, extending motor life
- Ideal for most heavy-duty industrial applications
- Collet Size: 1/4"
- No Load RPM: 18 000
- Air Inlet: 1/4"
- Air Consumption: 4.5 CFM
- Min. Hose Size: 3/8"
- Overall Length: 12-1/2"

Model No. UAV939
Mfg. No. 402215
Price/Each \$352.00



RIGHT-ANGLE DIE GRINDER

- Ergonomic and lightweight
- Durable metal housing and powerful vane motor
- Collet Size: 1/4"



Model No.	Mfg. No.	Air Consumption	Air Inlet	Sound Level (dBA)	No Load RPM	Price /Each
BW372	301B	6 CFM	1/4" NPT	104.8	21000	126.00

307B DIE GRINDER

- Easily reach tight workspaces with a right angle configuration and a compact, straight option
- Great for porting, weld grinding, smoothing edges, de-burring and polishing
- Collet Size: 1/4"



Model No.	Mfg. No.	Air Consumption	Air Inlet	Sound Level (dBA)	No Load RPM	Price /Each
BW380	307B	6 CFM	1/4" NPT	94	28000	111.00

308B DIE GRINDER

- Compatible with "piped away" exhaust kits
- Collet Size: 1/4"



Model No.	Mfg. No.	Air Consumption	Air Inlet	Sound Level (dBA)	No Load RPM	Price /Each
NKD061	308B	7	1/4" NPT	103	25000	169.00

302B DIE GRINDER

- Easily reach tight workspaces with a right angle configuration and a compact, straight option
- Collet Size: 1/4"



Model No.	Mfg. No.	Air Consumption	Air Inlet	Sound Level (dBA)	No Load RPM	Price /Each
TU676	302B	6 CFM	1/4" NPT	101	20000	208.00

MAX ANGLED DIE GRINDER

- Ergonomic design
- Collet Size: 1/4"



Model No.	Mfg. No.	Air Consumption	Air Inlet	Sound Level (dBA)	No Load RPM	Price /Each
NKD064	5102MAX	6 CFM	1/4" NPT	95.1	20000	314.00

MAX DIE GRINDER

- Lightweight, low-vibration
- Collet Size: 1/4"



Model No.	Mfg. No.	Air Consumption	Air Inlet	Sound Level (dBA)	No Load RPM	Price /Each
NKD026	5108MAX	6 CFM	1/4" NPT	94.3	25000	285.00

AIR TOOLS



UTILITY HAMMERS

- Ideal for structural maintenance and repair
- Air Consumption: 25 CFM
- Air Inlet: 1/4" NPTF
- Sound Level (dBA): 100



UAG272



UAG273

AURORA TOOLS

Model No.	BPM	Bore & Stroke	Cold Rivet Capacity	Head Material	Overall Length	Chisel Shank	Bore Diameter	Price /Each
UAG272	3000	3/4" x 2-5/8" (19.0mm x 66.0mm)	1/4" (6.4 mm)	Steel	7-1/2" (190 mm)	0.401" (Round)	3/4" ID (19.05 mm)	89.25
UAG273	2200	3/4" x 3-5/8" (19.0mm x 92.0mm)	5/16" (7.9 mm)	Steel	9-13/16" (250 mm)	0.401" (Round)	3/4" ID (19.05 mm)	99.75

HEAVY-DUTY AIR RIVETER

- 90 PSI air pressure recommended for maximum performance
- Powerful pulling load of 1940 lbs.
- Can be used on all rivet material types, including steel and aluminum, up to 3/16"
- 9/16" stroke sets rivets in one hit, increasing efficiency
- Very compact and lightweight – only 3.2 lbs.
- High quality, see-through collection bottle
- Air relief valve prevents overloading for greater tool service life
- Designed for professional automotive and

Model No. UAV953
Mfg. No. 409005
Price/Each \$276.00

light- to medium-duty industrial applications

- Rivet Size: 3/32" - 3/16"
- Air Inlet: 1/4"
- Average Air Consumption: 4 CFM
- Min. Hose Size: 3/8"
- Includes:
 Air Riveter,
 3/32" (2.4 mm) Nosepiece,
 1/8" (3.2 mm) Nosepiece,
 5/32" (4.0 mm) Nosepiece,
 3/16" (4.8 mm) Nosepiece



AURORA
TOOLS

Celebrating
15
YEARS

**EXCEEDING
EXPECTATIONS**



AIR FLUX CHIPPERS & NEEDLE SCALERS

- Lightweight compact design permits increased operator efficiency
- Paddle style trigger offers better speed control and precision
- Low noise, low vibration
- Durability and longer life

TLZ133

- Overall length: 10 1/4"
- Weight: 4.1 lbs.
- Comes with 35 mm flat chisel

- **Available accessories:** TLZ134 – 20 mm flat chisel
TLZ135 – 35 mm flat chisel
TLZ136 –moil point

TLZ131

- Overall length: 16"
- Weight: 6.1 lbs.
- Comes with 19 needles
- Replacement needles TLZ132



AURORA TOOLS

Model No	Stroke		Blows per minute BPM	Average Air Consumption CFM	Air Inlet	Hose Size		Vibrations Less Than m/s ²	Sound Pressure Level dB(A)	Price /Each
	in	mm				in	mm			
TLZ133	1-1/2	38	4400	9	1/4" – 18 NPT	3/8	9.5	10.2	92	215.00
TLZ131	1-1/2	38	4000	9	1/4" – 18 NPT	3/8	9.5	10.2	104.3	238.00

6-PIECE SUPER HEAVY-DUTY AIR HAMMER KIT

- The tool-free, rotating exhaust-direction dial allows users to direct the exhaust to either the front or handle of the tool
- The super heavy-duty kit features a swivel air inlet to prevent the air hose from twisting during operation
- The anti-vibration mechanism reduces user fatigue, and the one-piece rubber over-moulded grip reduces shock and slippage
- Constructed with a feature trigger for precise speed control, this air hammer kit comes with an ergonomic handle grip for optimal balance and control
- Air Consumption: 3.7 CFM
- Air Inlet: 1/4" NPT
- Sound Level (dBA): 95
- BPM: 2000
- Min. Hose Size: 3/8"
- Piston Diameter: 3/4"
- Piston Stroke: 3.54"
- Includes: (5) Chisel bits, (1) Quick-change retainer, (1) Blow-mold case

Model No. UAV943
Mfg. No. 404136
Price/Each \$352.00



HD14 DUAL CARTRIDGE HANDHELD DISPENSER

- Compatible with all cartridge ratios (1:1, 2:1, 4:1, 10:1)
- Conversion kit for all 4 ratios is included with each dispenser
- Cartridge kits are interchangeable between manual/pneumatic models
- Dual drive rod mechanism and ratio selector switch for improved dispensing performance
- Cartridge Capacity: (400 ml (13.5 oz.))

Model No. AH176
Mfg. No. 2693825
Price/Each \$1149.00



HEAVY-DUTY CHIPPING HAMMER

- This powerful and hard hitting tool offers the perfect balance of performance and life
- Outside teasing throttle for safety and control
- Saw tooth handle to cylinder connection for durability
- Air Consumption: 28 CFM
- Air Inlet: 3/8" NPT
- BPM: 1500
- Bore & Stroke: 1-1/8" x 4" (43mm x 101mm)
- Air Inlet: 3/8"
- Collar Type: 0.680 Round

Model No. UAV945
Mfg. No. 404329
Price/Each \$935.00



TAKING THE STRESS OUT OF SPILLS



AIR TOOLS



3" AIR CUT-OFF TOOLS

- Polyurethane handle reduces operator fatigue and vibration
- Power/speed regulator allows for easy PSI adjustment
- Twin-bearing design for smooth operation and cut off powerfully
- Wrench and Allen Key included to lock/unlock the disc
- Cut off wheel dimensions compatible with tool is 3" diameter x 0.060" thick (or thicker) x 3/8" arbour

Model No. THZ677



AURORA
TOOLS

Model No.	Cutting Wheel		Free Speed RPM	Average Air Consumption CFM		Hose Size		Horsepower HP	Vibration Less Than m/s ²	Sound Pressure Level dB(A)	Net Weight		Price /Each
	in	mm		Air Inlet	in	mm	lbs.				kg		
THZ677	3	76.2	21 000	3	1/4"-18 NPT	3/8	9.5	0.45	0.2	81	1.8	0.82	73.45

HEAVY-DUTY PISTOL GRIP AIR SHEAR

- For maximum performance we recommend 90 PSI air pressure
- Professional air shear for heavy duty applications
- Features a two gear, heavy duty planetary system for increased torque
- Popular pistol grip design for ease of operation
- Handle exhaust directs exhaust air away from the work piece and the operator
- Ideal for shearing steel, aluminum and most types of plastic
- Shear cuts maximum steel thickness: Regular Steel, Aluminum, Stainless Steel 1.24 mm
- Keep blades sharp for extended service life
- Air Inlet: 1/4" NPT
- Sound Level (dBA): 85
- Cutting Capacity: 18 Gauge
- Air Inlet: 1/4"
- Min. Hose Size: 3/8"
- Aluminum Cutting Capacity: 13 Gauge
- HP: 0.35
- Strokes Per Minute: 2200

Model No. UAV944

Mfg. No. 404163

Price/Each \$269.00



5" PNEUMATIC ANGLE GRINDERS

- Polyurethane grip reduces operator fatigue and vibration
- 5/8" x 11 UNC spindle
- Powerful twin – chamber motor-delivers much higher torque
- Side handle and wrenches included

Model No. THZ674



AURORA
TOOLS

Model No.	Grinding Wheel		Spindle Thread		Free Speed RPM	Average Air Consumption CFM		Hose Size		Vibration Less Than m/s ²	Sound Pressure Level dB(A)	Net Weight		Price /Each
	in	mm	in	mm		Air Inlet	in	mm	lbs.			kg		
THZ674	5	127	5.8	15.9	10 000	5	1/4" - 18 NPT	3/8	9.5	3.1	83	3.1	1.41	205.00

5" DUAL-ACTION ORBIT SANDERS

- Dual-action, compact and lightweight design
- Lever throttle offers one hand control
- Low vibration for swirl-free finishes
- Non-vacuum model
- Pad size (5"-6")
- Orbit diameter: 3/32" (2.5 mm)
- Overall length: 6 1/2"
- Weight: 1.8 lbs.
- Stick-on pad comes standard (TLZ472)
- Optional Hook & Loop pad (TLZ473)

Model No. TLZ142



AURORA
TOOLS

6" DUAL-ACTION ORBIT SANDERS

- Dual-action, compact and lightweight (ergonomic) design
- Lever throttle offers one hand control
- Low vibration for swirl-free finishes
- Non-vacuum model
- Pad size (5"-6")
- Overall length: 7"
- Weight: 1.9 lbs.
- Stick-on pad comes standard (TLZ474)
- Optional Hook & Loop pad (TLZ475)

Model No. TLZ143



AURORA
TOOLS

Model No.	Free Speed RPM	Average Air Consumption CFM	Air Inlet	Hose Size in mm	Horse Power HP	Vibrations Less Than m/s ²	Sound Pressure Level dB(A)	Price /Each
TLZ142	10 000	9	1/4" - 18 NPT	3/8 9.5	0.35	0.80	78	230.00
TLZ143	10 000	9	1/4" - 18 NPT	3/8 9.5	0.35	0.80	78	230.00

XTRACT™ PNEUMATIC RANDOM ORBITAL SANDER

- Vacuum-ready for use with 3M Xtract™ Portable Dust Extractor or central vacuum system
- Lightweight, comfortable design
- Soft-touch grip with moulded-in grip features
- Powerful 0.28 HP (209W) pneumatic motor
- Stays cool and comfortable while running
- Three variable speed settings
- The rear threaded attachment enables easy, secure attachment and detachment of a 1" (25.4 mm) external threaded vacuum hose (sold separately) to effectively help eliminate dust from the workpiece and surrounding space
- When used with 3M Xtract™ Net Discs and dust extraction, the system extracts up to 97% of the dust created during sanding
- No Load RPM: 12000

Model No.	Mfg No.	Sand Paper Size"	Orbit Diameter"	Vacuum Type	Price /Each
UAV687	AB28506	5	3/16	Central Vacuum	425.65
UAV681	AB88944	5	3/8	Central Vacuum	337.34
UAV689	AB88948	5	3/8	Self-Generated Vacuum	364.21
UAV679	AB88760	6	3/32	Central Vacuum	733.51
UAV692	AB28517	6	3/32	Self-Generated Vacuum	382.51

3M



BELT SANDERS

- Ideal for sanding, blending and smoothing operations in various industries
- Low maintenance motor
- Easy belt changes
- Air Consumption At Free Speed L/s: 6.8
- Hose I.D.: 3/8"



UAG276



UAG275

AURORA
TOOLS

Model No.	Mfg. No.	Air Consumption	Air Inlet	Sound Level (dBA)	Belt Size	No Load RPM	Power HP	Wattage	Weight lbs.	Weight kg	Price /Each
UAG276*	GS-0630J	16 CFM	1/4" NPTF	85	20-2/5" - 3/4"	16500	0.5	373	1.94	0.88	292.00
UAG275	GS-0630H	16 CFM	1/4" NPTF	85	13" - 3/8"	16500	0.5	373	1.94	0.88	225.00

* Right hand usage only, not reversible

AIR TOOLS



COIL ROOFING NAILER

- High speed valve technology drives at a rate of up to 10 nails per second
- Robust engine and feed system for durability and long life
- Depth adjust wheel with numbered detents helps drive nails to the proper depth into a variety of materials
- Steel skid plates with rubber inserts protect the tool and help to stop it from sliding
- Firing Mode: Bump Fire
- Nail Diameter: 0.12"
- Tool Weight: 5.2 lbs.



Model No.	Mfg. No.	Operating Pressure	Nail Length	Magazine Capacity	Magazine Angle	Price /Each
UAG131	DW45RN	70 - 120 PSI	3/4" - 1-3/4"	120	15°	459.00

COIL SIDING & FENCING NAILER

- Tool-free adjustable exhaust
- Tool-free adjustable rafter hook for convenience
- Durable, lightweight aluminum housing
- Drives wire weld and plastic inserted coil nails
- Smooth rubber foot aids in preventing damage to work surface
- Tool-free depth of drive adjustment for precise setting of fasteners
- Nail Diameter: 0.08" - 0.092"
- Tool Dimensions: 10.5" L x 4" W x 11" H
- Tool Weight: 4.9 lbs.



Model No.	Mfg. No.	Operating Pressure	Nail Length	Magazine Capacity	Magazine Angle	Price /Each
UAI796	DW66C-1	70 - 120 PSI	1-1/4" - 2-1/2"	300	15°	605.00

2-IN-1 FLOORING TOOL

- Mallet-actuated pneumatic driving action consistently drives fasteners for easier installation
- Special hardened driver blade for long life
- Ergonomically designed long handle with comfortable rubber grip
- Non-marring, interchangeable base plates for 1/2" - 3/4" flooring
- Includes: DWFP12569 Nailer, 1/2" Interchangeable base plate, 5/8" Interchangeable base plate, 3/4" Interchangeable base plate, Mallet, Wrenches, 1/4" Air fitting
- Staple Crown: 1/2"
- Weight: 10.2 lbs.
- Manufacturer's Warranty: 3 Years Limited



Model No.	Mfg. No.	Air Consumption	Staple Size	Nail Type	Magazine Capacity	Price /Each
TYD805	DWFP12569	100 psi	15.5 Gauge	Cleat	100	355.00

WIRE WELD FRAMING NAILER

- Industrial grade design for high speed and high volume framing applications
- Lightweight with enhanced ergonomics and balance for comfort and control
- Recoil dampening engine system to minimize recoil
- Depth-of-drive adjustment for precise setting of fasteners
- Selectable trigger for sequential or bump actuation
- Adjustable rafter hook
- Nail Diameter: 0.113" - 0.131"
- Tool Dimensions: 20.5" L x 4.95" W x 12.75" H
- Tool Weight: 8.1 lbs.



Model No.	Mfg. No.	Operating Pressure	Nail Length	Magazine Capacity	Magazine Angle	Price /Each
UAI795	DWF83WW	70 - 120 PSI	2" - 3-1/4"	100	28°	465.00

PAPER TAPE COLLATED FRAMING NAILER

- Industrial grade design for high speed and high volume framing applications
- Lightweight with enhanced ergonomics and balance for comfort and control
- Recoil dampening engine system to minimize recoil
- Depth-of-drive adjustment for precise setting of fasteners
- Selectable trigger for sequential or bump actuation
- Adjustable rafter hook
- Nail Diameter: 0.113" - 0.131"
- Tool Dimensions: 19.7" L x 4.95" W x 12.75" H
- Tool Weight: 8.1 lbs.



Model No.	Mfg. No.	Operating Pressure	Nail Length	Magazine Capacity	Magazine Angle	Price /Each
UAI793	DWF83PT	70 - 120 PSI	2" - 3-1/4"	90	30°	465.00

FINISH STAPLER

- Long life maintenance-free motor to keep from staining the work surface
- Tool-free depth-of-drive adjustment for proper setting of staples
- Selectable trigger for sequential or contact actuation
- Low staple lockout alerts when to reload
- Rear exhaust to keep contaminants away from work
- Staple Crown: 1/4"
- Tool Dimensions: 9.25" L x 2.75" W x 9.5" H
- Tool Weight: 3 lbs.
- Includes: Finish stapler, Carrying case, 1/4" Fitting, Owner's manual



Model No.	Mfg. No.	Operating Pressure	Staple Size	Staple Length	Magazine Capacity	Price /Each
UAI790	DWFP1838	70 - 120 PSI	16 Gauge	1/2" - 1-1/2"	100	199.00

PRECISION POINT™ FINISH NAILER

- Precision Point™ Technology allows precise nail placement as a result of a smaller nose and no need to compress the contact trip to actuate the tool
- Long life maintenance-free motor to keep from staining the work surface
- Tool-free jam release mechanism for easy nail removal
- Tool-free depth-of-drive adjustment for proper setting of nail heads
- Selectable trigger for sequential or contact actuation
- Rear exhaust to keep contaminants away from work
- Adjustable belt hook
- Nail Length: 1-1/4" - 2-1/2"
- Tool Dimensions: 12.5" L x 3.3" W x 11.3" H
- Tool Weight: 3.9 lbs.
- Includes: Nailer, 1/4" Air fitting, Carrying case, Extra no-mar tips



Model No.	Mfg. No.	Operating Pressure	Nail Size	Nail Type	Magazine Capacity	Price /Each
UAI791	DWFP71917	70 - 120 PSI	16 Gauge	Finishing	100	299.00

LIQUID TRANSFER & CLEAN-UP SYSTEMS

Ideally suited for recovering a wide variety of wet materials such as: coolants, hydraulic oils, non-flammable liquids, sludge and wet chips, waste water.

- Collects high viscosity liquids with efficiency
- Transforms an ordinary 205L drum into a powerful liquid vacuum cleaner; a simple two-way air control valve and 80-100 PSI air pressure allows pumping to a sealed drum
- Larger tank (205L) capacity than industrial shop vacuums
- Safe in wet areas, no electricity; eliminates the risk of electric shocks often associated with electric pumps
- Eliminates double handling of toxic materials and emptying of vacuum container
- Eliminates need for cloth and granular absorbents and their disposal problems
- Easy to clean; the pump can be completely disassembled
- Easily switches from vacuum mode, filling the container, to empty mode by turning the dial on top of the unit
- Instant On/Off control from air valve
- Automatic float valve to prevent overfilling
- Includes: pump unit, 10' vacuum hose with tapered PVC couplings, tapered PVC drum adaptor, extension tubes, crevice tool, skimmer tool, and squeegee
- Drum not included

Model No TG142 Vacuum and transfer system
Mfg. No. 67.400
Price/Each \$1346.00



TG143



TG142
Drum not included

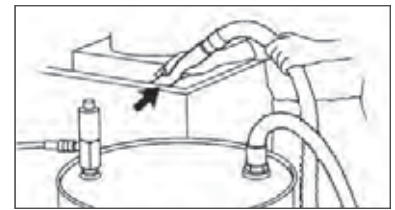

TG144



TG150



TG148



TG146

SPARE PARTS

Model No.	Mfg. No.	Description	Price/Each
TG143	67.410	Vacuum/pump unit	1080.00
TG144	67.415	10' Vacuum Hose	176.00
TG145	67.420	Squeegee	138.00
TG146	67.425	19" extension tube	46.30

Model No.	Mfg. No.	Description	Price/Each
TG147	67.430	Male drum adaptor 2"	73.70
TG148	67.435	Crevice tool	38.20
TG149	67.440	Round brush	52.80
TG150	67.445	Skimmer	36.00

TOPRING

GUNVAC® DELUXE VACUUM KIT

- Rugged, all metal construction
- Contoured comfort grip
- Convenient hanging eyelet
- High filtration collection bag with zipper
- 5 piece plastic accessory kit included
- 1/4" FNPT bottom and rear inlets
- Air Consumption: 78 CFM
- Air Inlet: 1/4" NPTF
- Min. Compressor Required: 6.4 HP
- Dimensions (L x W x H): 30.5" x 8" x 1.5"
- Weight: 1.8 lbs.

Model No. TYK117
Mfg. No. 1510
Price/Each \$235.00



GUARDAIR®

GUNVAC® VACUUM GUN KITS

- Powerful and quiet
- Unique Venturi Jet creates a powerful vortex which multiplies input air flow more than 12-fold
- Lightweight, easy to use with comfortable grip
- Safe and efficient-no need for electricity
- Reusable collector bag with rear deflector to extend bag's lifespan
- 1/4 (F) NPT inlet and working pressure 60 to 125 PSI
- Includes: reusable collector bag, 40 cm flexible hose, dust brush, crevice tool

Model No. TG151
Mfg. No. 67.050
Price/Each \$185.00



TOPRING

GUNVAC® VACUUM UNITS

The most powerful pneumatic GunVac® available and it handles like a blow gun. Vacuums metal chips, debris, sawdust, pellets, trimmings, and crumbs instead of blowing them. Sumps can be drained by removing the bag and connecting vac to a drum with a hose. It has no electrical fields or wires. Kit comes complete with 9" crevice tool. Constructed of rugged aluminum, it has a 1/4" NPT inlet and operates at 80-160 PSI. Tapered vacuum inlet accepts all standard 1-1/4" vac accessories.

Model No. TB155
Mfg. No. 1500
Price/Each \$177.00



GUARDAIR®

FLEXIBLE GUNVAC® VACUUM

- Rugged, all metal construction
- Contoured comfort grip
- Convenient hanging eyelet
- High filtration collection bag with zipper
- 8" x 1-5/16" O.D. flexible metal extension
- 1/4" FNPT bottom and rear inlets
- Air Consumption: 78 CFM
- Air Inlet: 1/4" NPTF
- Min. Compressor Required: 6.4 HP
- Dimensions (L x W x H): 30.5" x 8" x 1.5"
- Weight: 2.2 lbs.

Model No. TYK118
Mfg. No. 1548
Price/Each \$229.00



GUARDAIR®



HEAVY-DUTY AIR BLOW GUN, 7-PC. KITS

- Impact and weather resistant nylon body
- Ergonomic soft rubber grip
- Variable speed trigger controls the amount of air dispensed
- Brass threaded air inlet ensures that threads do not shear
- Silent operation with noise level under 80 dB
- 1/4" (F) - 18 NPT air inlet
- Maximum working pressure: 235 PSI
- Operating temperature: -10° C to 70° C

INCLUDED IN THE KIT:

- Heavy-duty safety blow gun w/4 1/2" long S.S. nozzle
- 4" protective shield provides safety from projectiles
- Soft rubber star tip nozzle for use on delicate materials
- Venturi nozzle for turbo charging output
- 1/2" rubber tip for blowing out lines and cavities
- 1" rubber tip for blowing out lines and cavities
- 1 3/8" rubber tip for blowing out lines and cavities

Model No. TYB523
Price/Each \$99.95

AURORA
TOOLS



HEAVY-DUTY BLOW GUNS

- Impact and weather resistant nylon body
- Ergonomic soft rubber grip
- Variable speed trigger controls the amount of air dispensed
- Brass threaded air inlet ensures that threads do not shear
- Silent operation with noise level under 80 dB
- 1/4" (F) - 18 NPT air inlet
- Operating Pressure: 50 - 235 PSI
- Operating temperature: -10° C to 70° C



AURORA
TOOLS

Model No.	Comes with	Air Consumption CFM	Noise Level at 100 PSI	Standard(s) Met	Price/Each
TYB519	-	9.53	77 dB	-	32.15
TYB520	Snub Nose Rubber Tip	15.89	77 dB	OSHA STD 1-13.1	36.75
TYB521	4 1/2" Long Stainless Steel Nozzle	15.18	80 dB	OSHA STD 1-13.1	37.20
TYB522	5 1/2" Long Stainless Steel Nozzle and Silencer	13.42	75 dB	OSHA STD 1-13.1	45.30

AIR BLOW GUN

- With metal reinforcement, brass inlet and steel nozzle
- Air Inlet: 1/4" NPT
- Air Consumption: 30 CFM
- Maximum Working Pressure: 120 PSI
- Tip: Standard
- Colour: Blue

Model No. UAV708
Price/Each \$12.75



AURORA
TOOLS

4" ANGLED NOZZLE BLOW GUN

- Full pressure nozzle
- Features a U.S.A.-patented brass air inlet
- Air Inlet: 1/4 NPT
- Tip: Standard

Model No. UAV845
Mfg. No. 028381
Price/Each \$15.90



AIR BLOW GUNS WITH BRASS SAFETY NOZZLE

- Contoured design fits comfortably in operators hand
- Brass tip increases air flow
- Cushioned thumb lever
- Hook design allows for easy and convenient storage
- Operating Pressure: 90 - 120 PSI
- 1/4" (F) - 18 NPT inlet

Model No. TLV118
Price/Each \$12.95



AURORA
TOOLS

BLOW GUN KIT WITH 5 INTERCHANGEABLE TIPS

- Contoured design fits comfortably in operators hand
- Chrome plated
- Large hanging hook
- Operating Pressure: 90 - 120 PSI
- 1/4" (F) - 18 NPT
- Comes with five tips: Non-marking soft rubber tip, large needle tip, narrow needle tip, inflating needle tip and metal tip

Model No. TLZ147
Price/Each \$16.70

AURORA
TOOLS



AIRPRO SAFETY BLOW GUNS W/VENTURI NOZZLE

Features

- Specially designed to project a large volume of air at low velocity
- Venturi function increases the amount of inlet air by 250%
- With 4" tube • Colour: Red

Applications

- Automotive and industrial applications
- Ideally suited for moving a large volume of chips or drying or cooling

Model No. UW573 Mfg. No. 60.386 Price/Each \$43.40



AIRPRO SILENT MAXIMUM SAFETY BLOW GUNS

Features

- Meets the safety requirements of OSHA and other health and safety agencies' strictest norms
- Reduction valve in the handle of the blow gun limits the pressure to 30 PSI
- Pressure is controlled so that it does not exceed 30 PSI as recommended by OSHA and other safety agencies' requirements
- With 5" tube • Colour: Red

Applications

- For cleaning equipment where maximum safety is required
- For very delicate operations requiring small quantity of air

Model No. UW576 Mfg. No. 60.389 Price/Each \$53.70

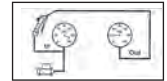

30 PSI

AIRPRO SILENT SAFETY BLOW GUNS

Features

- Specially designed to keep noise level under 75 dB
- With 5" tube • Colour: Red

Applications

- Ideal for automotive and industrial cleaning applications
- Ideal for the electronics industry, repair shops or other industries requiring a low noise level and precise control of air flow

Model No. UW574 Mfg. No. 60.387 Price/Each \$46.90



AIRPRO HIGH PERFORMANCE BLOW GUNS W/THROTTLE SCREW

Features

- Adjustable knob controls the amount of air supplied
- Ergonomic design reduces hand fatigue
- With 4" tube • Colour: Red

Applications

- Ideal for cleaning equipment in industries, as well as automobile repair shops
- Perfect for uses where reduced air flow is required

Model No. UW579 Mfg. No. 60.392 Price/Each \$53.10



AIRPRO SILENT SAFETY BLOW GUNS W/CONTROL THROTTLE SCREW

Features

- Specially designed to keep noise level under 75 dB
- With 5" tube • Colour: Red

Applications

- Ideal for automotive and industrial cleaning applications
- Ideal for the electronics industry, repair shops or other industries requiring a low noise level and precise control of air flow

Model No. UW575 Mfg. No. 60.388 Price/Each \$65.20



AIRPRO HIGH PERFORMANCE BLOW GUNS

Features

- 12" or 20" long tip
- Ideal for cleaning places which are not easily accessible
- Colour: Red

Applications

- Ideal for cleaning motors, equipment and machinery in industrial and agricultural sectors

12" LONG

**Model No. UW580
Mfg. No. 60.393
Price/Each \$45.60**

20" LONG

**Model No. UW581
Mfg. No. 60.395
Price/Each \$50.00**

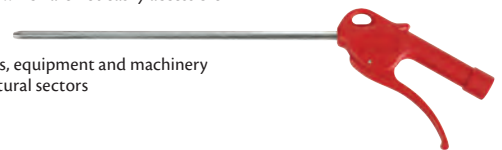

TOPRING

AIRPRO HIGH PERFORMANCE BLOW GUNS

Features

- Angled Tube • Powerful air stream
- With 4" tube • Colour: Red

Applications

- Ideal for cleaning equipment in industries, as well as automobile repair shops

Model No. UW577 Mfg. No. 60.390 Price/Each \$22.60

AIRPRO SAFETY BLOW GUNS

Characteristics

- A very compact gun with exclusive features
- The contoured body lies perfectly in the palm of the hand and with only one finger you can operate the progressive valve which adjusts the flow with a sensitive and gradual manner
- The body is made to protect the palm of the hand against the connection fittings
- Especially indicated for specialized fields such as: car repair, aviation etc... where compact size, progressive flow and anti-scratch materials are required

Specifications

- Working temperature: -4°F to 176°F (-20°C to 80°C)
- Maximum working pressure: 150 PSI

Applications

- Air, water, oil, grease, glue

SAFETY BLOW GUNS W/VENTURI NOZZLE

- Eliminates risk if hole is obstructed
- With 4" tube
- Colour: Blue

**Model No. TA835
Mfg. No. 60.350
Price/Each \$39.50**

HIGH PERFORMANCE BLOW GUNS

- Straight tip 12" long
- Colour: Blue

**Model No. TA832
Mfg. No. 60.325
Price/Each \$43.60**

HIGH PERFORMANCE BLOW GUNS

- Curved tip 4" long
 - Colour: Blue
- Model No. TA831
Mfg. No. 60.320
Price/Each \$20.00**

RUBBER TIP BLOW GUNS

- Anti-scratch tip
- Will not scratch or mark surfaces
- Colour: Blue

Applications

- Used in automotive and industrial shops for blowing out blocked passages such as automatic transmissions, carburetors, moulds and dies

**Model No. TA833
Mfg. No. 60.330
Price/Each \$30.50**



TOPRING

AIR TOOLS

BLIND HOLE AIR GUNS

The most effective blind hole air gun available, it is ideal for both deep crevices and blind holes.

This air gun is 100% effective in delivering a high velocity jet of air to flush out chips and dirt. It has a small diameter air tube to access into holes down to 1/8" diameter, a 1/4" NPT air inlet, and a maximum operating pressure of 120 PSI. Safety air shield provides effective chip-guarding as required by OSHA. Pistol grip casting and angled extension make this light weight air gun easy to handle. It has a 4" straight extension and a 2" extension after the 45 degree bend.

Model No. TB136
Mfg. No. 74BH006Z
Price/Each \$51.60

GUARDAIR®

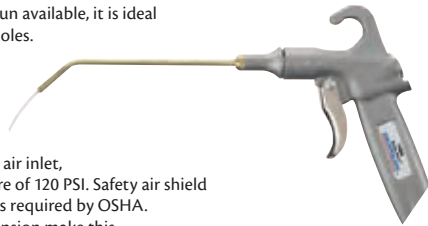

JET GUARD® SAFETY AIR GUNS

Ideally suited for machine shop and production line operation, it provides for years of dependable, non-fatiguing, effective operation. It incorporates a protective air cone which is recognized by OSHA as an effective safeguard for reducing injury from flying chips. An operator controlled knurled adjusting nut to control air volume. Air thrust can be set for whisper or blast.

Model No. TB137
Mfg. No. 74SK
Price/Each \$47.60

GUARDAIR®



WHISPER JET® SAFETY AIR GUNS

The quietest safety air gun available has a unique nozzle with a serrated periphery that reduces noise levels 6-20 dB less than conventional air guns. Solid conical tip design prevents blockage of nozzle, has a 1/4" NPT inlet with a maximum operating pressure of 150 PSI meets NPT standard.

Model No. TB151
Mfg. No. 80WJ
Price/Each \$46.90

GUARDAIR®



SYPHON SPRAY GUNS

The most economical spray gun available. Ideal for spraying thin and medium solutions such as oils, solvents, insulating compounds, metal preservatives and coatings. Operates on compressed air with no moving electrical parts. The high vacuum syphon delivers up to 16 gallons per hour, has a 1/4" NPT inlet and maximum operating pressure of 150 PSI meets OSHA standards. It includes a 12" extension for reaching difficult, hard to reach locations, 6 feet of feed tube and sinker, and an adjustable trigger and nozzle tip to control volume and spray pattern.

Model No. TB152
Mfg. No. 79SG012
Price/Each \$125.00

GUARDAIR®

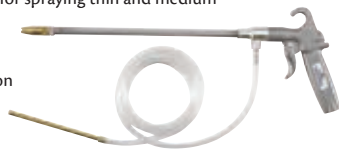

SYPHON SPRAY GUN KITS

- High vacuum syphon delivers up to 12 gallons per hour, knurled adjusting nut controls air volume
- Both 6" and 12" extensions allow for a longer reach
- One quart metal screw-on canister eliminates feed tubes and buckets
- 1/4" FNPT inlet
- Includes: Gun, canister, 6" rigid and 12" flexible plastic spray nozzles
- Conforms to MIL-G-952 type 1
- Meets OSHA standards



GUARDAIR®

Model No.	Mfg. No.	Description	Price/Each
TLZ783	79SGM	Siphon Spray Gun Kit	279.00

XTRA-THRUST® SAFETY AIR GUNS

The most powerful safety air gun available, it is designed to quickly move large volumes of debris. The Venturi tip increases thrust, with a 1/4" inlet and a maximum operating pressure of 150 PSI, resulting in a very high volume of air that equals 1/2" open pipe in effectiveness, yet meets OSHA standard with a limit of 30 PSI dead end static pressure. Constructed with rugged, cast aluminum body and full length trigger. For maximum performance of XTRA Thrust Air Gun high flow couplers and connectors of 5/16" interior diameter are recommended, as opposed to 3/16" I.D. for standard couplers and connectors.



GUARDAIR®

Model No.	Mfg. No.	Overall Length"	Price /Each
TB138*	75XXT	6	49.90
TB139	75XT012AA	12	62.10
TB140	75XT024AA	24	67.10
TB141	75XT036AA	36	72.10
TB142	75XT048AA	48	77.00
TB143	75XT060AA	60	82.00
TB144	75XT072AA	72	87.00

* Includes air gun and nozzle only

HIGH FLOW CONNECTORS FOR XTRA-THRUST

Model No.	Description	Price /Each
TB156	Connector, male 1/4" NPT 5/16" I.D.	8.73
TB158	1/4" hose barb for 1/4" hose	40.90
TB159	3/8" hose barb for 3/8" hose	35.50

LONG JOHN SAFETY AIR GUNS

The longest safety air gun available, it is ideal for cleaning areas that are hard to reach. Long John air guns are used for blowing floor debris into piles, cleaning masonry forms, tanks, ovens, large molds, pipelines, rafters as well as heavy machinery and storage areas. These air guns meet OSHA standards, has a 1/4" NPT inlet with a maximum operating pressure of 150 PSI. The pistol grip casting and aluminum extension make Long John lightweight and easy to handle. Special Venturi tip increases thrust by 200%.

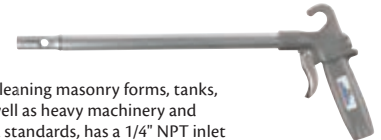

GUARDAIR®

Model No.	Mfg. No.	Extension Length"	Price /Each
TB130	75LJ012AA	12	53.80
TB131	75LJ024AA	24	58.80
TB132	75LJ036AA	36	63.80
TB133	75LJ048AA	48	68.80
TB134	75LJ060AA	60	73.80
TB135	75LJ072AA	72	78.70

900LI THUMB SWITCH SAFETY AIR GUN

The lightest, thumb lever operated, extended reach, safety air gun available. It is ideal for cleaning and drying machines, ovens, floors and rafters and production equipment. It fits comfortably in the palm of your hand and is constructed of an economical, rugged, die cast aluminum. The Venturi tip has a 1/4" NPT inlet, and a maximum operating pressure 120 PSI, boosts the thrust and limits static pressure to less than 30 PSI when tip is blocked. Meets OSHA standards.



GUARDAIR®

Model No.	Mfg. No.	Overall Length"	Price /Each
TB145	900LJ012AA	12	46.80
TB146	900LJ024AA	24	50.80
TB147	900LJ036AA	36	54.80
TB148	900LJ048AA	48	58.80
TB149	900LJ060AA	60	62.70
TB150	900LJ072AA	72	66.70

WHISPER JET® EXTENDED REACH AIR GUNS

- Durable cast aluminum body
- Unique Coandaire® nozzle reduces noise 6 to 20 dB compared to conventional air guns
- Solid conical tip design prevents blockage of nozzle
- Standard stock lengths from 6" - 72"
- 1/4" FNPT inlet
- Meets OSHA standards



GUARDAIR®

Model No.	Mfg. No.	Description	Price/Each
TLZ747	80LJ006AA	Whisper Jet® w/ Aluminum Extension & Aluminum Nozzle, 6"	55.20
TLZ748	80LJ012AA	Whisper Jet® w/ Aluminum Extension & Aluminum Nozzle, 12"	57.70
TLZ749	80LJ018AA	Whisper Jet® w/ Aluminum Extension & Aluminum Nozzle, 18"	60.20
TLZ750	80LJ036AA	Whisper Jet® w/ Aluminum Extension & Aluminum Nozzle, 36"	67.70
TLZ751	80LJ048AA	Whisper Jet® w/ Aluminum Extension & Aluminum Nozzle, 48"	72.60

LAZER® SERIES PALM SAFETY AIR GUNS

- All-metal construction with rubber over-molded trigger
- Unique shape and soft over-molded trigger conforms to any hand
- Ergonomic grip reduces hand fatigue
- Ready for use with any 1/4" NPT inlet connector
- Features 1/8" NPSM outlet for optional safety nozzles
- Meets OSHA 1910.242(b) regarding output pressure



GUARDAIR®

Model No.	Mfg. No.	Description	Price/Each
TLZ759	LZR600	Palm Switch Style Lazer Air Gun	31.20
TLZ760	LZR600006AA	Palm Switch Style Lazer Air Gun w/6" extension	51.40
TLZ761	LZR600012AA	Palm Switch Style Lazer Air Gun w/12" extension	52.90
TLZ762	LZR600018AA	Palm Switch Style Lazer Air Gun w/18" extension	54.00
TLZ763	LZR600024AA	Palm Switch Style Lazer Air Gun w/24" extension	55.20
TLZ764	LZR600036AA	Palm Switch Style Lazer Air Gun w/36" extension	57.80
TLZ765	LZR600048AA	Palm Switch Style Lazer Air Gun w/48" extension	60.40
TLZ766	LZR600060AA	Palm Switch Style Lazer Air Gun w/60" extension	63.00
TLZ767	LZR600072AA	Palm Switch Style Lazer Air Gun w/72" extension	65.60

FORCE 5® SERIES AIR GUNS

- Advanced Venturi nozzle delivers 100% of the power
- Air speed increases as it passes through the nozzle, drawing surrounding ambient air through the side ports
- The increased volume of air greatly intensifies power at the tip
- Meets OSHA Standards



GUARDAIR®

Model No.	Mfg. No.	Description	Price/Each
TLZ769	F5024AA	Force 5 Series with 24" Aluminum Extension And Standard Nozzle	411.00
TLZ770	F5036AA	Force 5 Series with 36" Aluminum Extension And Standard Nozzle	420.00
TLZ771	F5048AA	Force 5 Series with 48" Aluminum Extension And Standard Nozzle	428.00
TLZ772	F5060AA	Force 5 Series with 60" Aluminum Extension And Standard Nozzle	437.00

900 THUMB SWITCH SAFETY AIR GUN

The most compact safety air gun available that fits in the palm of your hands. It is constructed of an economical, rugged die cast aluminum. The Venturi tip, consisting of a 1/4" NPT inlet with a maximum operating pressure of 120 PSI, boosts the thrust and limits static pressure to less than 30 PSI. **TB154** includes an air shield to prevent hazardous chip fly-back.



GUARDAIR®

STANDARD MODEL

Model No. TB153
Mfg. No. 900
Price/Each \$23.00

WITH AIR SHIELD

Model No. TB154
Mfg. No. 900S
Price/Each \$29.30

LAZER® SERIES PISTOL GRIP SAFETY AIR GUNS

- All-metal construction
- Unique design offers comfort for any size hand
- Ergonomic grip reduces hand fatigue
- Ready for use with any 1/4" NPT inlet connector
- Features 1/8" NPSM outlet for optional safety nozzles
- Meets OSHA 1910.242(b) regarding output pressure



GUARDAIR®

Model No.	Mfg. No.	Description	Price/Each
TLZ752	LZR650	Pistol Grip Style Lazer Air Gun	31.20
TLZ753	LZR650006AA	Pistol Grip Style Lazer Air Gun w/ 6" extension	51.40
TLZ754	LZR650012AA	Pistol Grip Style Lazer Air Gun w/12" extension	52.90
TLZ755	LZR650018AA	Pistol Grip Style Lazer Air Gun w/18" extension	54.00
TLZ756	LZR650024AA	Pistol Grip Style Lazer Air Gun w/24" extension	55.20
TLZ757	LZR650036AA	Pistol Grip Style Lazer Air Gun w/36" extension	57.80
TLZ758	LZR650048AA	Pistol Grip Style Lazer Air Gun w/48" extension	60.40

EASY ACCESS SAFETY AIR GUNS

- Durable cast aluminum body
- Patented air-shield protective air cone protects operator from dangerous chip fly-back
- Delivers high thrust in hard to reach areas
- 6" screw-on brass extension
- 1/4" FNPT inlet
- Meets OSHA standards



GUARDAIR®

Model No.	Mfg. No.	Description	Price/Each
TLZ768	765006	Booster Safety Air Gun	43.20

QUIET FORCE™ NOZZLES

- Made from rugged, lightweight components
- Nozzle is ideal for noise sensitive applications
- Up to 20 dBA quieter than conventional nozzles
- Develops 7 lbs. of thrust using 130 SCFM @100 PSI
- Meets OSHA Standards



GUARDAIR®

Model No.	Mfg. No.	Description	Price/Each
TLZ773	F5024AQF	24" Force 5 (Quiet Force™ nozzle)	627.00
TLZ774	F5036AQF	36" Force 5 (Quiet Force™ nozzle)	636.00
TLZ775	F5048AQF	48" Force 5 (Quiet Force™ nozzle)	644.00
TLZ776	F5060AQF	60" Force 5 (Quiet Force™ nozzle)	653.00
TLZ777	F5072AQF	72" Force 5 (Quiet Force™ nozzle)	662.00

INFORCER AIR GUNS

- Super Venturi nozzle accelerates air flow
- 3/4" FNPT inlet, adjustable handle
- Thermally insulated ergonomic grip
- Palm or finger actuated dead man safety trigger



SPECIFICATIONS

Incoming Air Line Pressure (PSI)	Flow (SCFM)	Thrust (lbs.)
120	185	12

GUARDAIR®

Model No.	Mfg. No.	Description	Price/Each
TLZ778	INF5024AA	Inforcer 24" Air Gun with Aluminum Ext and Std Nozzle	443.00
TLZ779	INF5036AA	Inforcer 36" Air Gun with Aluminum Ext and Std Nozzle	452.00
TLZ780	INF5048AA	Inforcer 48" Air Gun with Aluminum Ext and Std. Nozzle	461.00
TLZ781	INF5060AA	Inforcer 60" Air Gun with Aluminum Ext and Std Nozzle	469.00

THE ORIGINAL SAFETY AIR GUNS

- Patented protective air cone protects operator from dangerous chip fly-back
- Venturi nozzle draws in ambient air to intensify both power and thrust
- Knurled adjusting nut controls air volume
- 1/4" FNPT inlet, convenient hanging hook
- Meets OSHA standards



GUARDAIR®

Model No.	Mfg. No.	Description	Price/Each
TLZ782	57S30XB	The Original Safety Air Gun with Volume Control	50.60



INADEQUATE PIPING & HOSES INFORMATION

The largest pressure loss in a system serving air tools is found in two areas: hoses that are too long and hoses that are too small. The longer the hose, the more friction is created, regardless of size; this can be addressed by increasing hose size. For this reason, small diameter hoses inevitably limit flow. Choosing the proper diameter hose for the distance and flow required will go a long way to limiting pressure loss at the tool.

RECOMMENDED FLEXIBLE HOSE SIZES (I.D.) FOR VARIOUS DISTANCES & FLOWS

Flow (SCFM)	Pressure PSI	Distance							
		25'	35'	50'	75'	100'	150'	200'	
1	100	1/4	1/4	1/4	1/4	1/4	1/4	1/4	
2	100	1/4	1/4	1/4	1/4	1/4	1/4	1/4	
5	100	1/4	1/4	1/4	1/4	5/16	5/16	3/8	
10	100	5/16	5/16	3/8	3/8	3/8	1/2	1/2	
15	100	3/8	3/8	1/2	1/2	1/2	1/2	1/2	
20	100	3/8	1/2	1/2	1/2	1/2	3/4	3/4	
25	100	1/2	1/2	1/2	1/2	3/4	3/4	3/4	
30	100	1/2	1/2	1/2	3/4	3/4	3/4	3/4	
40	100	1/2	3/4	3/4	3/4	3/4	3/4	3/4	
50	100	3/4	3/4	3/4	3/4	3/4	3/4	1	
60	100	3/4	3/4	3/4	3/4	3/4	1	1	
70	100	3/4	3/4	3/4	3/4	1	1	1	
80	100	3/4	3/4	3/4	1	1	1	1	
90	100	3/4	3/4	1	1	1	1	1	
100	100	3/4	3/4	1	1	1	1	1	

Calculations based on a pressure loss (ΔP) of maximum 5 PSIG

AIR HOSES NYLON COIL C/W FITTING

- Light and easy to handle
- High impact and abrasion resistance
- Excellent elastic memory, can be stretched repeatedly yet return to original shape for convenient storage
- Colour: High-viz yellow
- Temperature range: -5°C to 70°C



AURORA
TOOLS

Model No.	NPT (M)	Length	Hose Inside Diameter"	Max. Working Pressure PSI	Price /Each
TLZ150	1/4	25'	1/4	200	12.90
TLZ153	3/8	50'	3/8	300	34.30

HYBRID AIR HOSE

- Hybrid air hose provides the no-compromise solution that allows both exceptional flexibility and superior abrasion and general wear resistance
- For demanding heavy duty truck and industrial applications, hybrid is the air hose solution of choice
- Exterior and interior hose layers: premium polymer for excellent flexibility
- Interlayer: reinforced polyester for strength and longevity
- Solid crush proof couplings for leak proof sealing: 1/4" fittings for 1/4" and 3/8" ID, and 1/2" fittings for 1/2" ID
- Temperature range: -40°C (-40°F) to +82°C (180°F) – wide spectrum of indoor/outdoor applications - ideal for extreme cold weather environments
- Abrasion resistant outer cover for service longevity
- UV, ozone, and chemical resistance for safety and long service life
- 300 PSI maximum working pressure, 4:1 safety factor (1200 PSI burst pressure)
- Length: 25'
- Working Pressure: 200 psi
- Format: Fixed Length
- Fitting Size: 1/4" NPT
- Inside Diameter: 3/8"

Model No. UAV951
Mfg. No. 408193
Price/Each \$60.80



AIR HOSE REPAIR KITS

- For a 3/8" hose, 1/4" NPT threads
- Set includes:**
1 hose splicer
1 hose end fitting
3 hose clamps
- Model No. TLZ149
Price/Each \$7.30



PLUG QUICK COUPLER KITS, 5 PIECES

- Set includes:**
One 1/4" quick coupler
One 1/4" female plug
Three 1/4" male plugs
- Model No. TLZ148
Price/Each \$17.30



AURORA
TOOLS

VOLUME/CAPACITY

1 in ³ (cubic inch) = 16.387 cm ³	1 m ³ = 35.3 ft ³
1 ft ³ (cubic feet) = 0.0283 m ³	1 litre = 0.001 m ³
1 ft ³ = 28.32 litres	1 litre = 0.0353 ft ³
1 gallon (US) = 3.785 litres	1 litre = 0.264 gallon (US)
1 gallon (imperial) = 4.546 litres	1 litre = 0.220 gallon (imperial)
1 cm ³ (cubic centimeter) = 0.0610 in ³	1 fl. ounce (imperial) = 28.413 ml
1 m ³ (cubic meter) = 1000 litres	1 litre = 35.2 ounces

LENGTH

1 inch = 25.4 mm	1 mm = 0.039 in
1 ft (feet) = 0.305 m	1 m = 3.28 ft

WEIGHT

1 ounce = 28.349 g	1 g = 0.035 ounce
1 pound = 453.592 g	1 kg = 2.205 lbs

EASYFLEX PREMIUM AIR HOSES W/FITTINGS

- Technopolymer engineered to be tough and ultra-flexible at extremely low temperatures
- Easily re-coiled after use, no memory
- Lightweight
- -65°F to 149°F, 300 PSI
- Rubber guard bend restrictors on hose assemblies to extend the life of the hose
- Colour: Yellow or blue



TOPRING

Model No.	Mfg. No.	Colour	Hose I.D."	Hose Length'	Fittings (M)NPT	Price /Each
TLZ735	72.164	Yellow	1/4	25	1/4	42.20
TLZ736	72.168	Yellow	1/4	50	1/4	73.10
TLZ737	72.170	Yellow	1/4	100	1/4	131.00
TLZ738	72.364	Yellow	3/8	25	1/4	49.40
TLZ739	72.368	Yellow	3/8	50	1/4	87.30
TLZ740	72.370	Blue	3/8	100	1/4	163.00

MAXPRO SELF-STORING NYLON AIR HOSES W/FITTINGS

- Self-storing
- Excellent abrasion resistance
- Swivel fittings allow maximum directional flexibility
- Reusable and repairable fittings
- -40°F to 180°F, up to 200 PSI
- Colour: Red



TOPRING

Model No.	Mfg. No.	Hose I.D."	Hose Length'	Fittings (M)NPT	Price /Each
TA181	11.421	1/4	12,5	1/4	38.40
TA182	11.441	1/4	25	1/4	50.60
TA185	11.641	3/8	25	3/8	83.40
TA187	11.681	3/8	50	3/8	124.00

REPLACEMENT SWIVEL FITTINGS

Model No.	Mfg. No.	Hose I.D."	Hose Length'	Fittings (M)NPT	Price /Each
TS332	11.042	1/4	-	1/4	14.60
TS334	11.062	3/8	-	3/8	25.20
TS335	11.065	3/8	-	1/4	20.00

FLEXHYBRID AIR HOSES W/FITTINGS

- Engineered hybrid polymer combining best features from PVC and rubber
- Superior flexibility, lightweight and economical
- 14°F to 140°F, 300 PSI
- Good resistance to oils, heat, ozone and abrasion
- Colour: Red



TOPRING

Model No.	Mfg. No.	Hose I.D."	Hose Length'	Fittings (M)NPT	Price /Each
TNB036	70.115	1/4	25	1/4	30.30
TNB037	70.119	1/4	50	1/4	56.60
BC368	70.316	3/8	25	1/4	31.70
BC370	70.318	3/8	50	1/4	54.90
BC376	70.415	1/2	25	3/8	57.70
BC380	70.419	1/2	50	3/8	100.00

AIRFLEX PREMIUM AIR HOSES W/FITTINGS

- Excellent abrasion resistance
- Medium oil resistance
- -40°F to 212°F, 250 PSI
- Quality general purpose rubber air hose
- Colour: Red

BU260



TOPRING

Model No.	Mfg. No.	Hose I.D."	Hose Length'	Fittings (M)NPT	Price /Each
BU260	71.114	1/4	25	1/4	51.90
UP477	71.118	1/4	50	1/4	87.90
BU282*	71.315	3/8	25	1/4	63.20
BU286*	71.319	3/8	50	1/4	111.00
BU285*	71.318	3/8	50	3/8	112.00
BU306	71.419	1/2	50	3/8	156.00
BU305	71.418	1/2	50	1/2	160.00

*Rubber guard bend restrictors to increase the life of air hose

TOPFLEX RUBBER AIR HOSES

- Maximum oil and heat resistance
- Spark resistant
- Reusable fittings – no crimping required
- -40°F to 212°F, 300 PSI
- Synthetic rubber cover
- Colour: Black



TA511



TNB038

TOPRING

Model No.	Mfg. No.	Hose I.D."	Hose Length'	Fittings (M)NPT	Price /Each
TNB038	77.125	1/4	25	1/4	79.70

TOPFLEX LOCK-ON AIR HOSES

Model No.	Mfg. No.	Hose I.D."	Hose Length'	Fittings (M)NPT	Price /Each
TNB039	77.128	1/4	50	1/4	152.00
TNB040	77.130	1/4	100	1/4	298.00
BU472	77.348	3/8	50	1/4	203.00
TNB042	77.338	3/8	50	3/8	204.00
TNB043	77.110	1/4	500	-	1351.00
TNB044	77.310	3/8	500	-	1835.00

REPLACEMENT REUSABLE FITTINGS

Model No.	Mfg. No.	Hose I.D."	Hose Length'	Fittings (M)NPT	Price /Each
TA511	41.861	1/4	-	1/4	3.60
TA512	41.862	3/8	-	1/4	3.64
TA526	41.880	1/4	-	Barb joint	3.17
TA527	41.881	3/8	-	Barb joint	5.07

FLEXCOIL SELF-STORING POLYURETHANE AIR HOSES W/FITTINGS

- Offers little resistance to pull and automatically recoils
- Swivel fittings allow maximum directional flexibility
- Reusable and repairable fittings
- -40°F to 158°F, 140 PSI
- Colour: Red

TA216



TOPRING

Model No.	Mfg. No.	Hose I.D."	Hose Length'	Fittings (M)NPT	Price /Each
TA216	17.610	1/4	15	1/4	45.40
TA217	17.615	1/4	20	1/4	57.40
TA218	17.620	1/4	25	1/4	62.70
TA219	17.625	1/4	30	1/4	90.30
TA220	17.650	1/4	50	1/4	106.00
TA226	17.710	3/8	15	3/8	101.00
TA227	17.714	3/8	15	1/4	101.00
TA230	17.720	3/8	25	3/8	133.00
TA231	17.724	3/8	25	1/4	133.00

AIR TOOLS

HOSE REEL

- Heavy-duty, reinforced steel stampings for increased strength
- For use with air and water
- Compact design allows reels to fit in tight locations
- Multi-position guide arms for multiple mounting options
- Kinkless, oil resistant high quality hose
- Spring rewind features long life spring with declutching arbor
- Durable, corrosion-resistant powder coat paint
- EPDM Rubber

AURORA
TOOLS



UAV178

Model No.	Inner Hose Diameter"	Hose Length'	Working Pressure	Hose End	Dimensions			Reel Outlet	Inlet	Price /Each
					W"	x D"	x H"			
UAV178	1/4	35	300 PSI	3/8" NPT	17-1/3	x 15	x 8-1/3	1/4" NPT	3/8" NPT	185.00
UAV179	3/8	25	300 PSI	3/8" NPT	17-1/3	x 15	x 8-1/3	1/4" NPT	3/8" NPT	190.00
UAV180	3/8	35	300 PSI	3/8" NPT	17-1/3	x 15	x 8-1/3	1/4" NPT	3/8" NPT	205.00
UAV181	3/8	50	300 PSI	3/8" NPT	18-7/10	x 17-1/2	x 8-1/2	1/4" NPT	3/8" NPT	275.00
UAV182	1/2	50	300 PSI	1/2" NPT	21-7/10	x 18-1/2	x 9-2/3	1/2" NPT	1/2" NPT	305.00

WELDING HOSE REEL

- Heavy-duty, reinforced steel stampings for increased strength
- Compact design allows reels to fit in tight locations
- Multi-position guide arms for multiple mounting options
- Kinkless, oil resistant high quality hose
- Spring rewind features long life spring with declutching arbor
- Durable, corrosion-resistant powder coat paint
- 1/4" oxygen and acetylene twin hose
- Leakproof double O-ring seals
- Grade R hose

AURORA
TOOLS



UAV184

Model No.	Inner Hose Diameter"	Hose Length'	Working Pressure	Hose End	Dimensions			Reel Outlet	Inlet	Price /Each
					W"	x D"	x H"			
UAV183	1/4	25	300 PSI	9/16" NPTF	17-1/3	x 15	x 8-1/3	1/4" NPT	9/16" NPTF	250.00
UAV184	1/4	50	300 PSI	9/16" NPTF	18-7/10	x 17-1/2	x 8-1/2	1/4" NPT	9/16" NPTF	275.00

LIGHTWEIGHT & ECONOMICAL INDUSTRIAL REELS

- Lighter spring driven hose reel designed for applications that are less demanding, yet require a product that can withstand industrial use
- Steel components are individually powder coated and teamed with composite materials, which virtually eliminates corrosion
- Lightweight for air or water - designed for less demanding applications yet can withstand industrial use - sold with hose

REELCRAFT



FH522

Model No.	Mfg. No.	Drive Type	Hose I.D."	Hose Length'	Max PSI	Hose Outlet (M) NPT"	Reel Inlet (F) NPT"	Reel Outlet (F) NPT"	Dimensions			Wt. lbs.	Price /Each
									W"	x D"	x H"		
STEEL & COMPOSITE REELS													
FH522	RT435-OLP	Spring	1/4	35	300	1/4	3/8	-	5 3/4	x 16 1/2	x 17 7/8	20	409.00
FH523	RT450-OLP	Spring	1/4	50	300	1/4	3/8	-	5 3/4	x 16 1/2	x 17 7/8	24	455.00
FH524	RT635-OLP	Spring	3/8	35	300	1/4	3/8	-	5 3/4	x 16 1/2	x 17 7/8	21	415.00
FH525	RT650-OLP	Spring	3/8	50	300	1/4	1/2	-	6 1/4	x 16 1/2	x 17 7/8	27	539.00
FI056	RT835-OLP	Spring	1/2	35	300	1/2	1/2	-	6 1/4	x 16 1/2	x 17 7/8	27	645.00
FI057	RT850-OLP	Spring	1/2	50	300	1/2	1/2	-	7 3/4	x 16 1/2	x 17 7/8	37	719.00

2-Year Limited Warranty Standard colour as shown - black composite/powder coat paint red base & guide arm

RETRACTABLE AIR & WATER HOSE REEL

- Ideal for indoor shop and industrial applications
- Made from premium quality impact-resistant polypropylene materials
- Positive latching mechanism locks hose at desired length
- Hybrid polymer hose helps eliminate kinks
- Features a 180-degree integrated wall and overhead swivel bracket
- Hose Length: 50'
- Working Pressure: 300 psi
- Inlet: 3/8" NPT
- Includes: 36" Inlet Hose
- Material: Polypropylene
- Max. Temperature: 100°C (210°F)
- Min. Temperature: -10°C (14°F)

Model No. **UAV844**
Mfg. No. 028283
Price/Each **\$305.00**

ITC





HOSE REELS

REELS CONTRIBUTE TO AN IMPROVED WORK ENVIRONMENT WHICH SAVES TIME, EQUIPMENT & MONEY

Standard features Include:

- Durable, corrosion-resistant powder coat paint
- Heavy-duty, reinforced steel stampings for increased strength
- Permanently lubricated for long, trouble-free service
- Multi-position guide arms for versatile mounting options
- Kinkless, high quality hoses
- Spring rewind features long life spring with declutching arbor



FH494



FH502



FH507



TN315

HEAVY-DUTY INDUSTRIAL STEEL REELS

Model No.	Mfg. No.	Drive Type	Hose I.D."	Hose Length'	Max PSI	Hose Outlet (M)NPT"	Reel Inlet (F)NPT"	Reel Outlet (F)NPT"	Dimensions				Wt. lbs.	Price /Each	
AIR or WATER reels for manufacturing plants, body shops, workshops, service stations, fabricators, spray booths - sold with hose															
TN315	4435-OLP	Spring	1/4	35	300	1/4	3/8	-	5 5/8	x	12 3/8	x	12 7/8	19	465.00
TN317	4625-OLP	Spring	3/8	25	300	1/4	3/8	-	5 5/8	x	12 3/8	x	12 7/8	20	475.00
TN316	5635-OLP	Spring	3/8	35	300	1/4	3/8	-	6 1/8	x	14	x	14 3/8	25	585.00
TN318	7650-OLP	Spring	3/8	50	300	1/4	1/2	-	7	x	19 3/4	x	20 1/4	43	825.00
TN319	7850-OLP	Spring	1/2	50	300	3/8	1/2	-	7	x	19 3/4	x	20 1/4	47	849.00
FI058	5450-OLP	Spring	1/4	50	300	1/4	3/8	-	6 1/8	x	14	x	14 3/8	26	615.00
NN152	5650-OLP	Spring	3/8	50	300	1/4	3/8	-	5 7/8	x	16 1/2	x	17 5/8	36	665.00
FH534	81100-OLP	Spring	3/8	100	300	3/8	1/2	-	10 1/2	x	24	x	25 3/8	82	1359.00
FH490	82100-OLP	Spring	1/2	100	300	1/2	1/2	-	10 1/2	x	24	x	25 3/8	95	1349.00
FH491	83050-OLP	Spring	3/4	50	250	3/4	3/4	-	10 1/2	x	24	x	25 3/8	88	1295.00
FH492	D83075-OLP	Spring	3/4	75	250	3/4	3/4	-	13	x	24	x	25 3/8	102	1679.00
FH493	D84050-OLP	Spring	1	50	250	3/4	1	-	15 3/4	x	24	x	25 3/8	103	1725.00
FH494	E9350-OLP	Spring	3/4	50	250	3/4	3/4	-	16 3/4	x	26 1/4	x	26 3/8	140	2049.00
FH495	E9450-OLP	Spring	1	50	250	3/4	1	-	16 3/4	x	26 1/4	x	26 3/8	157	2149.00
OIL - medium pressure - furnished standard with S.A.E. 100 RT1 one wire braid hose - sold with hose															
TN323	7850-OMP	Spring	1/2	50	3250	1/2	1/2	-	7	x	19 3/4	x	20 1/4	57	1145.00
GREASE or HYDRAULIC OIL- high pressure reel - furnished standard with S.A.E. 100 R2T two wire braid hose - sold with hose															
TN325	7650-OHP	Spring	3/8	50	4800	1/4	1/2	-	7	x	19 3/4	x	20 1/4	60	1345.00
WASHDOWN - high pressure reel with maximum product delivery - equipment cleaning, pressure washing - sold without hose															
FI059	PW7600-OHP	Spring	3/8	50	5000	-	1/2	3/8	7	x	19 3/4	x	20 1/4	43	925.00
FH496	PW81000-OHP	Spring	3/8	100	5000	-	1/2	1/2	10 1/2	x	24	x	25 3/8	86	1395.00
DUAL HYDRAULIC - medium pressure reel ideal for operating hydraulic cylinders, tools and equipment - sold with hose															
FH497	TH88050-OMP	Spring	1/2	50	2000	1/2	1/2	-	13	x	24	x	25 3/8	114	2759.00
FUEL DELIVERY - low pressure equipped with Viton® seals & fuel grade hose for mobile & permanent mount applications - sold with hose															
FH498	F7925-OLP	Spring	3/4	25	250	3/4	3/4	-	7	x	19 3/4	x	20 1/4	47	1169.00
FH499	F83050-OLP	Spring	3/4	50	250	3/4	3/4	-	10 1/2	x	24	x	25 3/8	89	1925.00
FH500	FD84050-OLP	Spring	1	50	250	1	1	-	15 3/4	x	24	x	25 3/8	120	2015.00
WELDING REELS - used for a wide variety of gases such as acetylene, Mapp gas, propane gas, natural gas and fuel gases - sold with hose															
FH501	TW7450-OLPT	Spring	1/4	50	200	note 1	1/4	-	7 3/8	x	19 3/4	x	20 1/4	50	1115.00
FH502	TW84100-OLPT	Spring	1/4	100	200	note 1	note 2	-	13	x	24	x	25 3/8	101	2125.00
HAND CRANK FOR AIR or WATER - designed for medium-duty applications requiring longer lengths of hose - sold without hose															
FH506	CA32106L	Manual	1/2	100	1000	-	1/2	1/2	19 3/4	x	17 3/4	x	20 1/4	40	505.00
FH507	CA32112L	Manual	1/2	200	1000	-	1/2	1/2	25 3/4	x	17 3/4	x	20 1/4	46	569.00
FH508	CA33112L	Manual	3/4	100	1000	-	3/4	3/4	19 3/4	x	17 3/4	x	20 1/4	46	729.00
HOSE REEL CART FOR 12" HAND CRANK REELS - 8" semi-pneumatic rubber tires, adjustable handle, rugged 1" square tubular steel frame															
FH509	600741-2	-	-	-	-	-	-	-	23 3/4	x	27	x	44 1/2	-	395.00



TN318



FH509

2-Year Limited Warranty - Note 1: 9/16" - 18 UNF Female Note 2: 9/16" - 18 UNF Male Note 3: 1" NPTM
 Note 4: Handle height adjustable to 35 5/8", 38 5/8", 41 1/2", 44 1/2" Standard colour as shown - powder coat paint red



CUT TO LENGTH TUBING



GENERAL PURPOSE FOR COMPRESSED AIR

Characteristics:

- Ideal for compressed air and water service
- Moderate resistance to oil
- Resists heat, sunlight, ozone and weather

Applications:

- Air tools

Specifications:

- Working temperature: 40°F to 200°F (40°C to 93°C)

Construction:

Tube: Black EPDM
 Cover: Red EPDM
 Reinforcement: Synthetic rubber - multiple textile plies

Model No.	Hose I.D."	Max. PSI	Price /Each Ft.
TA070	1/4	250	2.19
TA071	5/16	300	2.49
TA072	3/8	250	2.59
TA073	1/2	250	3.14
TZ899	3/4	250	4.69



MULTI-PURPOSE MEDIUM OIL RESISTANT (NON-CONDUCTIVE) TUBING

Characteristics:

- Double-reinforced makes it extra strong and tough
- Durable for rugged environmental conditions
- Economical and versatile general purpose hose (air and water)
- Lightweight, flexible
- Performs well in both hot and cold temperatures
- Long service life
- Available in lengths up 700' in one piece

Applications:

- Ideal for air tool and compressed air applications
- Used with all kinds of compressed air equipment found in foundries, shipyards, engineering workshops, construction sites, quarries and mines.

Specifications:

- Working temperature: -29°C to +82°C (-20°F to +180°F)
- Working pressure: 250 PSI two braids

Construction:

Tube: Black nitrile tube, Class A
 Cover: Red medium oil resistant nitrile blend, Class B
 Reinforcement: Spirals of synthetic yarn

Model No.	Hose I.D."	Hose O.D."	Wt. lbs. per 100'	Price /Each ft.
TA074	1/4	0.5	8	3.89
TA075	3/8	0.72	17	4.49
TA076	1/2	0.88	24	6.59

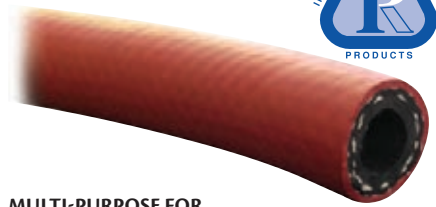

MULTI-PURPOSE FOR COMPRESSED AIR & FLUIDS

Characteristics:

- High quality multi-purpose hose
- Durable for longer life
- High flexibility
- Abrasion resistance
- Good resistance to oils and greases, gasoline and solvents
- May be used to transmit water, oil and many chemicals up to 300 PSI

Applications:

- Ideal for air tool applications

Specifications:

- Working temperature: -20°F to 250°F (-29°C to 121°C)
- Working pressure: 300 PSI two braids

Construction:

Tube: Black Buna-N
 Cover: Red neoprene
 Reinforcement: Synthetic fibre braids

Model No.	Hose I.D."	Hose O.D."	Wt. lbs. per 100'	Price /Each Ft.
TA081	1/4	0.63	18	3.59
TA082	3/8	0.72	20	3.79
TA083	1/2	0.88	27	5.19
TZ901	3/4	1.14	43	6.89
TA084	1	1.50	65	10.50

ROLAIR AUTOMATIC REWIND HOSE REELS W/PVC AIR HOSE

- Durable construction, made from high impact resistant polypropylene
- Compact design
- Double adjustment action to lock hose at desired length
- Sealed connection points at swivel and hose inlet to prevent leaks
- Integrated wall/overhead swivel bracket
- Non-sag hose rollers reduce hose wear
- Adjustable hose stopper
- 60" inlet hose included



TLV341

TOPRING

Model No.	Mfg. No.	Hose Width"	Hose Length'	Inlet (M) NPT"	Outlet (M) NPT"	Price /Each
TLV341	79.370	1/4	33	1/4	1/4	201.00
TLV342	79.375	3/8	30	1/4	1/4	218.00
TLV343	79.380	3/8	50	1/4	1/4	235.00

MANUAL REWIND AIR/WATER REELS

- This light weight hand crank reel is designed for general use and lighter-duty applications that require longer lengths of low pressure air/water hoses
- Economical choice for storing and retrieving hoses
- Brass swivel and brass inlet
- Maximum temperature 150°F (65°C)
- Hose not included and assembly is required



FI054

REELCRAFT

Model No	Hose I.D."	Outlet (F)NPT"	Inlet (F)NPT"	Hose Length'	Max PSI	Dimensions W" x D" x H"	Wt lbs.	Price /Each
FI054	3/8	3/8	3/8	50	300	16 3/4 x 10 1/2 x 11 1/2	12	225.00
FI055	3/8	3/8	3/8	100	300	21 1/8 x 10 1/2 x 11 1/2	16	265.00

QUICK COUPLERS

High performance, corrosion resistant quick couplers built to interchange with industrial type couplings. Offer a higher flow for maximum on-line performance of hand-held air tools. Heavy-duty, high quality design.

TOPRING

1/4 INDUSTRIAL INTERCHANGE

1/4 INDUSTRIAL PLUGS

- Zinc Plated or Stainless Steel 304
- Corrosion resistant

1/4 INDUSTRIAL AUTOMAX COUPLERS

- Automatic push-to-connect operation
- Proven and positive connection using pin-lock mechanism
- Max 250 PSI
- 37 SCFM

1/4 INDUSTRIAL MAXQUIK COUPLERS

- Manual operation
- Sleeve guard prevents accidental disconnection
- Max 250 PSI
- 24 SCFM



Size"	Model No.	Mfg. No.	Price/Each	Size"	Model No.	Mfg. No.	Price/Each	Size"	Model No.	Mfg. No.	Price/Each
FEMALE THREAD (F) NPT											
1/8	TA243	20.122	2.94	1/8	-	-	-	1/8	-	-	-
1/4	TA244	20.142	2.04	1/4	TZ184	20.444	11.10	1/4	TA268	20.842	9.31
1/4 (Stainless)	TLV344	20.146	12.50	1/4 (Stainless)	-	-	-	1/4 (Stainless)	-	-	-
3/8	TA245	20.162	4.27	3/8	-	-	-	3/8	TA269	20.862	12.90
MALE THREAD (M) NPT											
1/8	TA247	20.222	2.71	1/8	-	-	-	1/8	-	-	-
1/4	TA248	20.242	1.73	1/4	TZ185	20.644	11.90	1/4	TA271	20.942	9.31
1/4 (w/thread sealant)	TLV345	20.248	2.24	1/4 (w/thread sealant)	-	-	-	1/4 (w/thread sealant)	-	-	-
1/4 (Stainless)	TLV346	20.246	12.50	1/4 (Stainless)	-	-	-	1/4 (Stainless)	TLV348	20.946	42.70
3/8	TA249	20.262	2.97	3/8	TZ227	20.664	14.20	3/8	TA272	20.962	11.80
HOSE BARB											
1/4 I.D.	TA252	20.342	3.64	1/4 I.D.	TZ228	20.744	14.90	1/4 I.D.	TA258	20.542	13.70
3/8 I.D.	TA254	20.362	3.64	3/8 I.D.	TZ230	20.764	15.30	3/8 I.D.	TA260	20.562	14.20

3/8 INDUSTRIAL INTERCHANGE

3/8 INDUSTRIAL PLUGS

- Zinc plated steel construction
- Corrosion resistant

3/8 INDUSTRIAL AUTOMAX COUPLERS

- Automatic push-to-connect operation
- Proven and positive connection using pin-lock mechanism
- Max 250 PSI
- 62 SCFM

3/8 INDUSTRIAL MAXQUIK COUPLERS

- Manual operation
- Sleeve guard prevents accidental disconnection
- Max 250 PSI
- 56 SCFM

Size"	Model No.	Mfg. No.	Price/Each	Size"	Model No.	Mfg. No.	Price/Each	Size"	Model No.	Mfg. No.	Price/Each
FEMALE THREAD (F) NPT											
1/4	TA273	21.142	4.10	1/4	TA281	21.442	30.00	1/4	TZ144	21.842	23.80
3/8	TA274	21.162	4.54	3/8	TA282	21.462	30.70	3/8	TZ145	21.862	23.70
1/2	TZ132	21.182	7.77	1/2	TZ137	21.482	32.40	1/2	TZ146	21.882	27.60
MALE THREAD (M) NPT											
1/4	TA278	21.242	4.10	1/4	TZ138	21.642	32.50	1/4	TZ147	21.942	24.90
3/8	TA279	21.262	4.44	3/8	TA283	21.662	32.50	3/8	TZ148	21.962	24.90
1/2	TZ133	21.282	8.14	1/2	TZ139	21.682	33.80	1/2	TZ149	21.982	27.60
HOSE BARB											
3/8 I.D.	TA280	21.362	6.30	3/8 I.D.	TZ142	21.762	35.70	3/8 I.D.	TZ152	21.562	29.10
1/2 I.D.	TZ136	21.382	7.47	1/2 I.D.	-	-	-	1/2 I.D.	TZ153	21.582	29.10

1/2 INDUSTRIAL INTERCHANGE

1/2 INDUSTRIAL PLUGS

- Zinc plated steel construction
- Corrosion resistant

1/2 INDUSTRIAL AUTOMAX COUPLERS

- Automatic push-to-connect operation
- Proven and positive connection using pin-lock mechanism
- Max 250 PSI
- 99 SCFM

3/8 INDUSTRIAL MAXQUIK COUPLERS

- Manual operation
- Sleeve guard prevents accidental disconnection
- Max 250 PSI
- 75 SCFM

Size"	Model No.	Mfg. No.	Price/Each	Size"	Model No.	Mfg. No.	Price/Each	Size"	Model No.	Mfg. No.	Price/Each
FEMALE THREAD (F) NPT											
3/8	TZ154	22.162	7.51	3/8	-	-	-	3/8	-	-	-
1/2	TZ155	22.182	7.77	1/2	TZ165	22.482	38.70	1/2	TZ175	22.882	31.30
3/4	TZ156	22.192	13.10	3/4	-	-	-	3/4	TZ176	22.892	33.60
MALE THREAD (M) NPT											
3/8	TZ158	22.262	6.24	3/8	-	-	-	3/8	-	-	-
1/2	TZ159	22.282	7.21	1/2	TZ169	22.682	38.70	1/2	TZ179	22.982	32.20
3/4	TZ160	22.292	13.40	3/4	-	-	-	3/4	TZ180	22.992	31.90
HOSE BARB											
1/2 I.D.	TZ162	22.382	10.20	1/2 I.D.	-	-	-	1/2 I.D.	-	-	-

AIR TOOLS

FITTINGS

HOSE BARB SPLICERS



Model No.	Hose I.D."	Price/Each
TA492	1/4	1.63
TA493	5/16	2.37
TA494	3/8	2.37
TA495	1/2	4.10
TA496	5/8	5.24
TA497	3/4	7.54

HOSE BARB TO FEMALE PIPE CONNECTORS



Model No.	Hose I.D."	Thread (F) NPT	Price /Each
TZ072	1/4	1/8	2.90
TA502	1/4	1/4	3.04
TZ073	5/16	1/4	5.80
TA503	3/8	1/4	3.37
TA504	3/8	3/8	5.04
TA505	1/2	1/2	7.64

HOSE BARB COUPLERS TO FEMALE BALL END



Model No.	Hose I.D."	Thread (F) NPT	Price /Each
TZ098	1/4	1/4	6.91
TZ100	5/16	1/4	8.91
TZ101	3/8	1/4	7.01
TZ102	3/8	3/8	8.24

HOSE BARB COUPLERS FLAT SEAT WITH GASKET



Model No.	Hose I.D."	Thread (F) NPT	Price /Each
TZ105	1/4	1/4	12.20
TZ106	5/16	1/4	14.50
TZ107	3/8	1/4	14.50
TZ108	3/8	3/8	17.40
TZ109	1/2	1/2	21.20

HOSE BARB TO MALE PIPES



Model No.	Hose I.D."	Thread (M) NPT	Price /Each
TZ075	1/8	1/8	2.07
TZ076	3/16	1/8	2.07
TA498	1/4	1/8	2.20
TA499	1/4	1/4	2.31
TZ077*	1/4	1/4	8.27
TZ078	1/4	3/8	3.44
TZ079	5/8	3/8	5.14
TZ080	5/8	1/2	6.74
TZ081	5/8	3/4	13.30
TZ083	5/16	1/4	3.47
TZ084	3/8	1/8	3.50
TA500	3/8	1/4	2.37
TZ085*	3/8	1/4	9.44
TA501	3/8	3/8	3.34
TZ086*	3/8	3/8	12.70
TZ087	3/8	1/2	5.64
TZ088	1/2	1/4	3.40
TZ089	1/2	3/8	4.27
TZ090	1/2	1/2	4.60
TZ091*	1/2	1/2	13.90
TZ092	1/2	3/4	8.74
TZ093	3/4	1/2	6.44
TZ094	3/4	3/4	7.41
TZ095	1	3/4	10.00
TZ096	1	1	14.90

*Swivel

REUSABLE HOSE FITTINGS



Model No.	Hose O.D."	Hose I.D."	Thread (M) NPT	Price /Each
TZ110	1/2	1/4	1/4	17.60
TZ111	9/16	1/4	1/4	18.60
TZ112	5/8	1/4	1/4	18.60
TZ115	9/16	5/16	1/4	31.70
TZ119	5/8	3/8	1/4	19.70
TZ120	5/8	3/8	3/8	19.90
TZ121	11/16	3/8	1/4	20.30
TZ123	3/4	3/8	1/4	20.90
TZ128	7/8	1/2	1/2	39.00

UNIMAX 5-IN-1 UNIVERSAL COUPLERS

UNIVERSAL INTERCHANGE ACCEPTS:

- Ultraflo
- ARO 210
- Lincoln
- 1/4 Industrial
- 1/4 Truflate
- Automatic push-to-connect operation
- Sleeve guard protects against accidental disconnection when the coupler is dragged on the floor or over obstructions
- Deep knurled socket sleeve for positive gripping



Model No.	Mfg. No.	NPT	Price/Each
FEMALE THREAD			
TKZ830	20.441	1/4	21.70
MALE THREAD			
TKZ831	20.641	1/4	24.00

TOPRING

UNISAFE UNIVERSAL 5-IN-1 INTERCHANGE SAFETY COUPLERS

UNIVERSAL INTERCHANGE ACCEPTS:

- Ultraflo
- ARO 210
- Lincoln
- 1/4 Industrial
- 1/4 Truflate

- Valve sleeve is operated independently of locking sleeve
- When the valve sleeve is moved to shut off air flow downstream pressure is automatically vented
- Disconnection and connection are performed easily at zero pressure
- Automatic push-to-connect operation

Model No.	Mfg. No.	NPT	Price/Each
FEMALE THREAD			
TGA093	20.448	1/4	29.80
MALE THREAD			
TGA098	20.648	1/4	31.90

TOPRING

ARO 210 Type

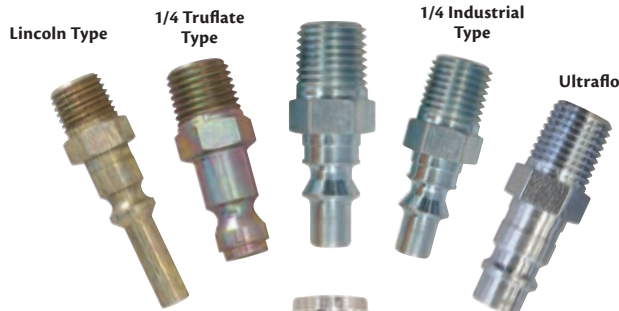

SAFETY COMES FROM 2-STEP DISCONNECTION:



Male/female connected set

Slide the black sleeve to release downstream pressure

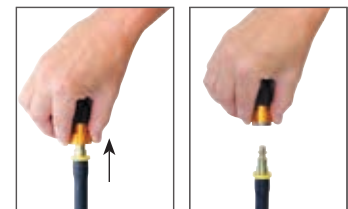

Slide the gold sleeve to release plug

Disconnection



TOPQUIK INDUSTRIAL SAFETY COUPLERS

- Prevents dangerous hose whip through 2-step disconnection
- Shock and crush resistant
- Non-marring body prevents scratching
- Super lightweight and ergonomic
- Maximum 225 PSI



TOPRING

3/8" COUPLER

1/4" COUPLER

Model No.	Mfg. No.	NPT	SCFM	Price/Each
FEMALE THREAD				
TLZ040	20.449	1/4	36	37.60
TLZ041	20.469	3/8	36	47.30
MALE THREAD				
TLZ042	20.649	1/4	36	44.40
TLZ043	20.669	3/8	36	46.50

Model No.	Mfg. No.	NPT	Price/Each
FEMALE THREAD			
TLZ044	21.449	1/4	56.80
TLZ045	21.469	3/8	56.80
TLZ046	21.489	1/2	57.40
MALE THREAD			
TLZ047	21.649	1/4	57.40
TLZ048	21.669	3/8	62.40
TLZ049	21.689	1/2	62.40

SAFETY COMES FROM 2-STEP DISCONNECTION:



- Slide the sleeve back to release downstream pressure
- The plug is released, but held within the coupler



- Slide the sleeve forward
- The plug is released completely



QUICKSILVER 1/4" INDUSTRIAL HIGH PRESSURE COUPLERS

- Delivers high air volume with low pressure drop for better tool performance
- Corrosion resistant for long service life
- Drag guard protects against accidental disconnection
- Automatic push-to-connect operation
- Maximum 500 PSI
- 44 SCFM

Model No.	Mfg. No.	NPT	Price/Each
FEMALE THREAD			
BC080	20.446	1/4	28.30
BC082	20.466	3/8	34.80
MALE THREAD			
BC090	20.646	1/4	33.70
BC093	20.666	3/8	35.50



BC080

TOPRING

1/4" INDUSTRIAL INTERCHANGE PLUGS

- Zinc Plated or Stainless Steel 304
- Corrosion resistant
- Made to precise standards to ensure fit

Model No.	Mfg. No.	NPT	Price/Each
FEMALE THREAD			
TA243	20.122	1/8	2.94
TA244	20.142	1/4	2.04
TLV344	20.146	1/4 (stainless)	12.50
TA245	20.162	3/8	4.27
MALE THREAD			
TA247	20.222	1/8	2.71
TA248	20.242	1/4	1.73
TLV345	20.248	1/4 (sealant)	2.24
TA249	20.262	3/8	2.97



TA243

TA247

TOPRING

Model No.	Mfg. No.	I.D."	Price/Each
HOSE BARB			
TA252	20.342	1/4	3.64
TA254	20.362	3/8	3.64

AUTOMAX ARO 210 INTERCHANGE COUPLERS

- Accepts ARO 210 Plugs
- Automatic push to connect operation
- Deep knurled socket sleeve
- Max PSI: 250
- 34 SCFM

TOPRING



TZ998



TS406

Model No.	Mfg. No.	NPT	Price/Each
FEMALE THREAD			
TZ998	23.444	1/4	10.70
MALE THREAD			
TS399	23.644	1/4	11.40

Model No.	Mfg. No.	I.D."	Price/Each
HOSE BARB			
TS406	23.764	3/8	15.90

AIR TOOLS

HOSE CLAMPS

STAINLESS STEEL BAND & SCREW



5/16" HEX HEAD SCREW 1/2" BAND

Model No.	Mfg. No.	Diameter Min."	Diameter Max."	Price/Each
TLY173	DHC5-6	0.375	0.875	1.03
TLY152	DHC5-10	0.5	1.125	1.59
TLY160	DHC5-20	0.75	1.75	1.99
TLY164	DHC5-24	1	2	1.79
TLY168	DHC5-40	1.125	3	2.39
TLY172	DHC5-56	2.125	4	1.69
TLY175	DHC5-64	2.625	4.5	3.29
TLY176	DHC5-72	3.125	5	2.69
TLY161	DHC5-212	11.75	13.75	1.19

HOSE CLAMPS

STAINLESS STEEL BAND & ZINC PLATED SCREW



5/16" HEX HEAD SCREW 1/2" BAND

Model No.	Mfg. No.	Diameter Min."	Diameter Max."	Price/Each
TLY205	DHC6-6	0.375	0.875	0.97
TLY208	DHC6-8	0.438	1	0.93
TLY182	DHC6-10	0.5	1.125	0.97
TLY191	DHC6-20	0.75	1.75	0.99
TLY195	DHC6-24	1	2	1.05
TLY196	DHC6-28	1.313	2.25	1.22
TLY198	DHC6-32	1.563	2.5	1.12
TLY200	DHC6-40	1.125	3	1.26
TLY202	DHC6-48	1.625	3.5	1.22
TLY203	DHC6-52	1.875	3.75	1.35
TLY207	DHC6-72	3.125	5	2.00
TLY210	DHC6-88	4.25	6	2.79
TLY183	DHC6-104	4	7	2.19
TLY184	DHC6-116	5.75	7.75	3.59
TLY186	DHC6-128	6.5	8.5	2.59
TLY189	DHC6-164	8.75	10.75	2.09
TLY190	DHC6-188	10.25	12.25	3.39
TLY192	DHC6-212	11.75	13.75	5.31

1-EAR HOSE CLAMPS



Model No.	Mfg No.	Size"	Price/Each
TLY262	DHC8-8 1/2	1/2	0.23
TLY212	DHC8-10	5/8	0.31
TLY217	DHC8-14	7/8	3.49
TLY219	DHC8-16	1	0.36

HOSE CLAMPS

STAINLESS STEEL BAND & ZINC PLATED SCREW



MINI-GEAR 1/4" HEX HEAD ZINC PLATED SCREW 5/16" BANDS

Model No.	Mfg. No.	Diameter Min."	Diameter Max."	Price/Each
TLY289	DMHC6-4	0.219	0.625	0.42
TLY291	DMHC6-6	0.438	0.875	0.54
TLY287	DMHC6-12	0.563	1.25	1.21
TLY288	DMHC6-16	0.813	1.75	1.33

HOSE CLAMPS

STAINLESS STEEL BAND & SCREW



MINI-GEAR 1/4" HEX HEAD SCREW 5/16" BANDS

Model No.	Mfg. No.	Diameter Min."	Diameter Max."	Price/Each
TLY283	DMHC5-4	0.219	0.625	0.52
TLY284	DMHC5-6	0.316	0.875	0.52
TLY281	DMHC5-12	0.563	1.25	1.16

KEY TURN HOSE CLAMPS

- Zinc Plated Screw
- Stainless Steel Band
- Will accept 40 to 50 inch/lbs. of torque on the key



TWO EAR CLAMP

Model No.	Mfg. No.	Size	Price/Each
TLY754	DKTC12-12	12.7-31.7 mm	1.11
TLY756	DKTC12-28	31.7-57 mm	1.76
TLY757	DKTC12-36	44.4-69.8 mm	2.58

NO JOB TOO TOUGH!



1.6 CONTINUOUS HP, 4.5-GALLON ELECTRIC WHEELED PORTABLE COMPRESSORS

- Vertical stand feature allows a user to transport or store compressor in a vertical position
- 78 dBA (tested per ISO3477) operational noise level for a quieter work environment
- 10" non-flat foam tires allow for easy transportation around the jobsite
- Oil free, maintenance free pump, for convenient use
- High flow coupler allows for maximum nailer performance
- Metal console panel provides gauges, couplers and regulators

Model No. TLV990 Mfg. No. D55146
Price/Each \$785.00

Horsepower: 1.6 HP
Tank Size: 4.5 Gal
Power Supply: 120V
CFM @ 100 PSI: 5.2
Max PSI: 175
Dimensions: 33.5" L x 23" W x 15" H
Weight: 83 lbs.



0.3 CONTINUOUS HP 1-GALLON SINGLE TANK HAND CARRY COMPRESSORS

- 0.75 SCFM delivered @ 90 PSI pump, 1.0 gallon tank and 135 max PSI enables more nails to be fired and provides quicker recovery
- Durable oil-free pump provides extended maintenance-free operation
- Low 71 dBA* allows for quieter operation (*Tested per ISO3744)
- Roll cage and control panel provide protection to key compressor components
- Low 2.6 amp draw motor provides easy start-up and reduces breaker tripping
- Ball valve drain allows for quick and thorough tank draining
- One quick coupler to easily support 1 nailer
- High-flow regulator for increased performance

Model No. TJZ977 Mfg. No. D55140
Price/Each \$235.00

Drive: Belt drive
Horsepower: 0.3 continuous HP
Tank Size: 1.0 gal.
Power Supply: 120 V, 10 A, 60 Hz, universal motor
CFM @90 PSI: 0.75 CFM
Pump Speed: 2200 RPM
Dimensions: 19" L x 14.5" W x 9" H
Weight: 29 lbs.



CONTINUOUS WHEELED AIR COMPRESSOR

- Cast iron cylinder enhances pump life
- High-flow regulator for increased performance
- Oil lubricated pump improves durability
- Dual soft start valves assist in cold weather start-up
- Top load panel with positioning holes allows unit to transport loads up to 100 lbs
- Run multiple tools from dual universal quick couplers
- Ball valve drain allows for quick and thorough tank draining
- Features 10" pneumatic wheels and handle for ease of mobility
- Electric/Gas: Electric
- CFM: 5 at 100 PSI



Model No.	Mfg. No.	Horse Power	Voltage /Phase	Tank Capacity	Max. PSI	Sound Level (dBA)	Pump Speed	Height"	Length"	Width"	Weight lbs.	Wheel Diameter"	Price /Each
TLV989	D55168	1.6HP	120/1	15 Gal. (18 US Gal)	225	78	1750 RPM	44-3/4	24-1/2	22	92	2	879.00

PORTABLE CONTRACTOR SERIES COMPRESSORS – OIL LUBE, DIRECT DRIVE

- For professional, farm, home and hobbyists
- Quiet running and low 1720 RPM pump
- Die cast aluminum pump with cast iron sleeves and stainless steel valves for longer life
- All electrical units draw 15 amps or under
- Manual reset for overload protection
- Includes: Regulator, pressure gauge, pressure switch with on/off, universal coupler, filter silencer with replacement element and pump oil
- Air outlet accepts 1/4" industrial male quick connector
- Factory tested prior to shipment
- Not intended for commercial use
- CSA approved
- 1-year limited manufacturer's warranty

TFA008



TFA009



TFA010



Model No.	Mfg. No.	Peak HP	Running HP @ 90 PSI	Actual FAD-CFM 90 PSI	Actual FAD-CFM 125 PSI	Voltage /Phase	Amp Draw @ 125 PSI	Tank Size (gal.)	Pump RPM	Dimensions L" x W" x H"	Wt. lbs.	Price /Each
TFA008	DD-1004	1	1	4.5	4	115 V/1 PH	15	4	1720	16 x 16 x 23	65	785.00
TFA009	DD-1503	1.5	1.5	6	4.6	115 V/1 PH	14	3.2	1720	22 x 9 x 23	55	725.00
TFA010	DD-2022B	2	1.5	6	4.6	115 V/1 PH	15	4	1720	21 x 20 x 20	80	799.00

COMPRESSORS



CONTRACTOR SERIES

- Direct drive units have splash lubricated pump with cast iron sleeve for longer life
- Belt drive units have durable cast iron pumps
- Splash type lubrication
- All cast iron pumps have steel valves for longer life
- Flywheels designed for excellent pump cooling
- Manual reset for overload protection
- Dual control-start/stop with pressure switch or constant speed operation for electric belt drive unit
- All gas units equipped with Honda® gas engines
- Idle-down throttle control for gas belt drive units
- Air outlet accepts 1/4" industrial male quick connector
- All units are factory tested prior to shipment
- 1-year warranty



TFA011



TFA017



TFA012



TFA014

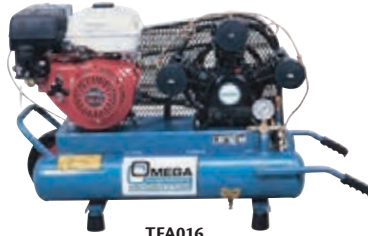

TFA016



TFA013

Model No.	Mfg. No.	Peak HP	Running HP @ 90 PSI	Actual FAD-CFM		Max. PSI	Voltage /Phase	Tank Size (gal.)	Noise Level dBA	Amp Draw @ 125 PSI	Pump RPM	Wt. lbs.	Remarks	Price /Each
				90 PSI	125 PSI									
TFA011	DP-2004V	2	1.5	6.0	4.6	125	115 V/1 PH	3.2	83	12	3450	55	Pan-Cake	929.00
TFA012	DP-2022H	2	1.5	6.0	4.6	125	115 V/1 PH	4	83	12	3450	65	Twin-Stack	929.00
TLV736	PUK-1508MDC	1.5	1.5	6.6	6.0	125	115 V/1 PH	8	70	15	1100	210	Twin-Tank	1829.00
TFA013	PUK-2008MDC	2	2.0	9.5	8.0	125	115 V/1 PH	8	70	22	900	200	Twin-Tank	2015.00
TFA014	PUK-5508G	5.5	5.5	12.5	10.5	125	5.5 HP Gas	8	90 Run/82 Idle	N/A	1100	190	Twin-Tank	2645.00
TFA015	PUK-5520G	5.5	5.5	12.5	10.5	125	5.5 HP Gas	20	90 Run/82 Idle	N/A	1100	190	20 gal. portable	2829.00
TFA016	PUK-9008G	9	9	20.6	17.6	125	9 HP Gas	8	90 Run/82 Idle	N/A	1100	250	Twin-Tank	4035.00
TFA017	TUE-8008GE	8	8	15.6	12.5	175	8 HP Gas	8	90 Run/82 Idle	N/A	1100	250	Electric Start	4429.00

PROFESSIONAL SERIES

- Quiet operation
- All units are belt driven
- Durable cast iron pumps
- Splash type lubrication
- All cast iron pumps have steel valves for longer life
- Flywheels designed for excellent pump cooling
- Manual reset for overload protection
- Portable units equipped with built-in regulator, pressure gauges and on/off switch
- Fully assembled - require handle and wheel attachment
- Air outlet accepts 1/4" industrial male quick connector
- All units are factory tested prior to shipment
- For professional and automotive applications
- 1-year warranty



TFA019



TFA023



TFA021



TFA022



TFA024



Model No.	Mfg. No.	HP	Actual FAD-CFM		Max. PSI	Voltage /Phase	Tank Size (gal.)	Noise Level dBA	Wt. lbs.	Remarks	Price /Each
			40 PSI	90 PSI							
TFA019	PK-2008	2	4.0	3.2	125	115 V /1 PH	8	80	90	Horizontal-Portable	1045.00
TFA020	PK-3011	3	6.0	5.3	125	115 V/1 PH	11	80	110	Horizontal-Portable	1195.00
TFA021*	PK-5020	5	-	7.8	135	115 V/1 PH	20	70	185	Horizontal-Portable	1565.00
TFA022	PK-5020VP	5	7.8	6.4	125	115 V/1 PH	20	70	150	Vertical-Portable	1635.00
TFA023	PP-6060V	6	12.5	11.0	125	230 V/1 PH	60	75	300	Vertical-15 A Motor	2549.00
TFA024	PK-6560V	6.5	20.0	18.0	125	230 V/1 PH	60	75	330	Electric Start	3265.00

* Peak HP 5HP and running 2HP at 90PSI

INDUSTRIAL SERIES

- Quiet operation
- Heavy-duty two-stage high efficient air compressors
- Durable cast iron pumps for performance and durability
- Splash type lubrication
- All cast iron pumps have steel valves for longer life
- Flywheels designed for excellent pump cooling
- Air outlet accepts 1/4" industrial male quick connector
- All units are factory tested prior to shipment
- For commercial, automotive and industrial applications
- 2-year warranty



5 HP VERTICAL COMPRESSORS – TWO STAGE

Mfg. No.:	TK-5080V	No. of cylinders:	3
CFM @ 100 PSI:	19.4	Pump RPM:	960
Max. PSI:	175	Noise Level:	79 dBA
Tank Size:	80 gallons	Wt. Lbs.:	600

Model No.	Mfg. No.	Voltage	Price/Each
TFA031	TK-5080V-01M	208-230 V - 1 phase	6325.00
TFA032	TK-5080V-02M	200-208 V - 3 phase	6325.00
TFA033	TK-5080V-03M	230-240 V - 3 phase	6325.00
TFA034	TK-5080V-04M	460-480 V - 3 phase	6325.00
TFA035	TK-5080V-05M	575-600 V - 3 phase	6325.00

5 HP HORIZONTAL COMPRESSORS – TWO STAGE

Mfg. No.:	TK-5080	No. of cylinders:	3
CFM @ 100 PSI:	19.4	Pump RPM:	960
Max. PSI:	175	Noise Level:	79 dBA
Tank Size:	80 gallons	Wt. Lbs.:	600

Model No.	Mfg. No.	Voltage	Price/Each
TFA041	TK-5080-01M	208-230 V - 1 phase	6325.00
TFA042	TK-5080-02M	200-208 V - 3 phase	6325.00
TFA043	TK-5080-03M	230-240 V - 3 phase	6325.00
TFA044	TK-5080-04M	460-480 V - 3 phase	6325.00
TFA045	TK-5080-05M	575-600 V - 3 phase	6325.00

7.5 HP VERTICAL COMPRESSORS – TWO STAGE

Mfg. No.:	TK-7580V	No. of cylinders:	2
CFM @ 100 PSI:	26.1	Pump RPM:	995
Max. PSI:	175	Noise Level:	78 dBA
Tank Size:	80 gallons	Wt. Lbs.:	650

Model No.	Mfg. No.	Voltage	Price/Each
TFA051	TK-7580V-01M	208-230 V - 1 phase	8455.00
TFA052	TK-7580V-02M	200-208 V - 3 phase	7669.00
TFA053	TK-7580V-03M	230-240 V - 3 phase	7669.00
TFA054	TK-7580V-04M	460-480 V - 3 phase	7669.00
TFA055	TK-7580V-05M	575-600 V - 3 phase	7669.00

7.5 HP HORIZONTAL COMPRESSORS – TWO STAGE

Mfg. No.:	TK-7580	No. of cylinders:	2
CFM @ 100 PSI:	26.1	Pump RPM:	995
Max. PSI:	175	Noise Level:	78 dBA
Tank Size:	80 gallons	Wt. Lbs.:	650

Model No.	Mfg. No.	Voltage	Price/Each
TFA061	TK-7580-01M	208-230 V - 1 phase	8455.00
TFA062	TK-7580-02M	200-208 V - 3 phase	7669.00
TFA063	TK-7580-03M	230-240 V - 3 phase	7669.00
TFA064	TK-7580-04M	460-480 V - 3 phase	7669.00
TFA065	TK-7580-05M	575-600 V - 3 phase	7669.00

10 HP HORIZONTAL COMPRESSORS – TWO STAGE

Mfg. No.:	TK-100120	No. of cylinders:	3
CFM @ 100 PSI:	36.1	Pump RPM:	843
Max. PSI:	175	Noise Level:	80 dBA
Tank Size:	120 gallons	Wt. Lbs.:	950

Model No.	Mfg. No.	Voltage	Price/Each
TFA070	TK-100120-02M	200-208 V - 3 phase	9229.00
TFA071	TK-100120-03M	230-240 V - 3 phase	9229.00
TFA072	TK-100120-04M	460-480 V - 3 phase	9089.00
TFA073	TK-100120-05M	575-600 V - 3 phase	9089.00

15 HP HORIZONTAL COMPRESSORS – TWO STAGE

Mfg. No.:	TK-150120	No. of cylinders:	3
CFM @ 100 PSI:	52.3	Pump RPM:	668
Max. PSI:	175	Noise Level:	80 dBA
Tank Size:	120 gallons	Wt. Lbs.:	1100

Model No.	Mfg. No.	Voltage	Price/Each
TFA078	TK-150120-02M	200-208 V - 3 phase	11360.00
TFA079	TK-150120-03M	230-240 V - 3 phase	11360.00
TFA080	TK-150120-04M	460-480 V - 3 phase	11360.00

20 HP HORIZONTAL COMPRESSORS – TWO STAGE

Mfg. No.:	TK-200120	No. of cylinders:	3
CFM @ 100 PSI:	70	Pump RPM:	890
Max. PSI:	175	Noise Level:	82 dBA
Tank Size:	120 gallons	Wt. Lbs.:	1160

Model No.	Mfg. No.	Voltage	Price/Each
TFA086	TK-200120-02M	200-208 V - 3 phase	12227.00
TFA087	TK-200120-03M	230-240 V - 3 phase	12227.00
TFA088	TK-200120-04M	460-480 V - 3 phase	13448.00
TFA089	TK-200120-05M	575-600 V - 3 phase	12227.00

25 HP HORIZONTAL COMPRESSORS – TWO STAGE

Mfg. No.:	TK-250240	No. of cylinders:	4
CFM @ 100 PSI:	87.7	Pump RPM:	542
Max. PSI:	175	Noise Level:	78 dBA
Tank Size:	240 gallons	Wt. Lbs.:	1500

Model No.	Mfg. No.	Voltage	Price/Each
TFA094	TK-250240-02M	200-208 V - 3 phase	22689.00
TFA095	TK-250240-03M	230-240 V - 3 phase	22689.00
TFA096	TK-250240-04M	460-480 V - 3 phase	21679.00
TFA097	TK-250240-05M	575-600 V - 3 phase	21679.00

30 HP HORIZONTAL COMPRESSORS – TWO STAGE

Mfg. No.:	TK-300240	No. of cylinders:	4
CFM @ 100 PSI:	100.8	Pump RPM:	650
Max. PSI:	175	Noise Level:	80 dBA
Tank Size:	240 gallons	Wt. Lbs.:	1500

Model No.	Mfg. No.	Voltage	Price/Each
TFA102	TK-300240-02M	200-208 V - 3 phase	23199.00
TFA103	TK-300240-03M	230-240 V - 3 phase	23199.00
TFA104	TK-300240-04M	460-480 V - 3 phase	22205.00
TFA105	TK-300240-05M	575-600 V - 3 phase	22205.00

11 HP GAS ENGINE COMPRESSORS

Mfg. No.:	TUK-1130GE	No. of cylinders:	3
CFM @ 100 PSI:	19.4	Pump RPM:	960
Max. PSI:	175	Noise Level:	90 dBA (run) 82 dBA (idle)
Tank Size:	30 gallons	Wt. Lbs.:	450

Model No.	Price/Each
TFA106	7789.00

COMPRESSORS



MODULAR FILTER, REGULATOR & LUBRICATOR (GAUGE INCLUDED)

- Components are attached in series using spacers and piping adapters, which make the individual components easily removable and mountable without disturbing the pipe line
- Comes complete with wall mounting bracket
- Air filter, regulator and lubricator come with NPT threads and gauge
- Operating Pressure: 7-145 PSI

AURORA
TOOLS



Model No.	Series	Connection Size	Max. Air Flow	Filter Bowl Capacity	Lubricator Bowl Capacity	Price /Each
POLYCARBONATE BOWL WITH STEEL BOWL GUARD						
TY181	FRL100	1/4" NPT	18 SCFM @ 105 PSI	0.30 oz.	0.68 fl. oz.	142.00
TY182	FRL200	3/8" NPT	71 SCFM @ 105 PSI	1.08 oz.	1.93 fl. oz.	178.00
TY183	FRL300	1/2" NPT	123 SCFM @ 105 PSI	1.50 oz.	5.17 fl. oz.	240.00
METAL BOWL						
TY184	FRL400	3/4" NPT	123 SCFM @ 105 PSI	5.60 oz.	6.80 fl. oz.	509.00
TY185	FRL400	1" NPT	175 SCFM @ 105 PSI	5.60 oz.	6.80 fl. oz.	509.00

MODULAR FILTER/REGULATOR & LUBRICATOR (GAUGE INCLUDED)

- Space-saving, two-piece combination is a popular air preparation unit
- Attached in series using spacers and piping adapters, which make the two components easily removable and mountable without disturbing the pipe line
- Come complete with a wall mounting bracket
- Operating Pressure: 7-145 PSI
- Bowl Material: Polycarbonate bowl with steel bowl guard

AURORA
TOOLS



Model No.	Series	Connection Size	Max. Air Flow	Filter Bowl Capacity	Lubricator Bowl Capacity	Price /Each
TY178	FRL100	1/4" NPT	18 SCFM @ 105 PSI	0.30 oz.	0.68 fl. oz.	130.00
TY179	FRL200	3/8" NPT	44 SCFM @ 105 PSI	1.08 oz.	1.93 fl. oz.	155.00
TY180	FRL300	1/2" NPT	99 SCFM @ 105 PSI	1.50 oz.	5.17 fl. oz.	230.00

MODULAR AIR LUBRICATOR

- Used to feed lubricants to pneumatic equipment and maintain a constant oil-to-air density over a wide range of flow
- Fog/Micro Mist type, up to 50' pipe runs
- The head is fitted with oil drop indicator, oil drop controller and oil filling plug
- Designed for best performance with 32-grade oil
- Comes with NPT threads
- Max. PSI: 145 PSI

AURORA
TOOLS



Vertical

Modular

Model No.	Series	Connection Size	Max. Air Flow	Bowl Capacity	Price /Each
MODULAR - POLYCARBONATE BOWL W/STEEL BOWL GUARD					
TY170	FRL100	1/4" NPT	48 SCFM @ 90 PSI	0.68 fl. oz.	43.95
TY171	FRL200	3/8" NPT	106 SCFM @ 90 PSI	1.98 fl. oz.	57.65
TY172	FRL300	1/2" NPT	200 SCFM @ 90 PSI	5.13 fl. oz.	80.20
VERTICAL - METAL BOWL					
TY173	FRL400	3/4" NPT	255 SCFM @ 90 PSI	6.8 fl. oz.	158.00
TY174	FRL400	1" NPT	318 SCFM @ 90 PSI	6.8 fl. oz.	158.00

MODULAR AIR FILTER/REGULATOR (GAUGE INCLUDED)

- Filter-Regulator combination is the most popular air preparation units, assembled together to form a single unit
- Regulators are used to maintain a steady outlet pressure, unaffected by variations or fluctuations in the inlet pressure
- Filter used to separate dust, dirt, moisture and other contaminants from compressed air
- Press-type manual drain with nighttime drain feature, which automatically drains off the bowl once the compressed air supply to the filter is switched off
- Filter has sintered bronze, 40-micron filtering element
- Comes with NPT threads and gauge
- Max. PSI: 145 PSI
- Bowl Material: Polycarbonate bowl with steel bowl guard

AURORA
TOOLS



Model No.	Series	Connection Size	Max. Air Flow	Bowl Capacity	Price /Each
TY175	FRL100	1/4" NPT	20 SCFM @ 105 PSI	0.3 fl. oz.	65.40
TY176	FRL200	3/8" NPT	64 SCFM @ 105 PSI	1.08 fl. oz.	94.15
TY177	FRL300	1/2" NPT	106 SCFM @ 105 PSI	1.5 fl. oz.	132.00

MODULAR AIR FILTER

- Used to separate dust, dirt, moisture and other contaminants from compressed air
- Sintered bronze, 40-micron filtering element
- Designed with a separator and shield for efficient moisture separation
- Press-type manual drain with nighttime drain feature, which automatically drains off the bowl once the compressed air supply to the filter is switched off
- Comes with NPT threads
- Drain Type: Semi-Automatic
- Material Filtered: Combination
- Filtration Size (Microns): 40 Microns



Model No.	Series	Max. PSI	Bowl Material	Connection Size	Price /Each
MODULAR					
TY165	FRL100	145	Polycarbonate	1/4" NPT	30.00
TY166	FRL200	145	Polycarbonate	3/8" NPT	49.95
TY167	FRL300	145	Polycarbonate	1/2" NPT	73.40
VERTICAL					
TY168	FRL400	290	Metal	3/4" NPT	165.90
TY169	FRL400	290	Metal	1" NPT	165.90



MODULAR AIR REGULATOR (GAUGE INCLUDED)

- Regulators are used to maintain a steady outlet pressure, unaffected by variations or fluctuations in the inlet pressure
- Regulators step down the air line pressure and can be set at any desired pressure below the inlet air pressure
- Designed with a non-raising "Press to Lock" adjustment knob for locking at any set pressure
- These can be installed in any position and need not be vertically mounted
- Comes with NPT threads and gauge
- Max. PSI: 220 PSI



Model No.	Series	Connection Size	Max. Air Flow	Price /Each
TY160	FRL100	1/4" NPT	21 SCFM @ 105 PSI	33.55
TY161	FRL200	3/8" NPT	88 SCFM @ 105 PSI	50.30
TY162	FRL300	1/2" NPT	140 SCFM @ 105 PSI	78.95
TY163	FRL400	3/4" NPT	175 SCFM @ 105 PSI	155.00
TY164	FRL400	1" NPT	210 SCFM @ 105 PSI	155.00



FILTERS/REGULATORS (GAUGE INCLUDED)

- High-flow capacity reduces costly pressure drop
- Compact size allows greater design flexibility
- Lightweight construction for ease of installation

TOPRING

Model No.	NPT Size"	Max SCFM @ 100 PSI	Max PSI	Reduced Pressure Range PSI	Max Temp. °F	Drain Type	Bowl Type	Bowl Cap. oz.	H"	W"	Price /Each
COMPACT MODULAR DESIGN, 5-MICROMETRES FILTRATION											
TA624	1/4	33	150	0-125	125	Manual	Polyurethane w/Guard	3.8	8 1/16	2 3/16	229.00
TA625	1/4	33	150	0-125	125	Auto	Polyurethane w/Guard	3.8	8 1/16	2 3/16	295.00
TA627	1/4	33	175	0-125	125	Auto	Zinc	3.8	8 1/16	2 3/16	317.00
TA634	1/2	78	250	0-125	150	Manual	Zinc	3.8	8 1/16	2 3/16	265.00
STANDARD DUTY MODULAR DESIGN, 5-MICROMETRES FILTRATION											
TA638	1/2	132	250	0-125*	150	Manual	Zinc	8.5	10 21/64	2 11/16	330.00
TA641	3/4	148	150	0-125*	120	Auto	Polyurethane w/guard	8.5	10 21/64	3 1/32	356.00
TA642	3/4	148	250	0-125*	150	Manual	Zinc	8.5	10 21/64	3 1/32	330.00
TA643	3/4	148	175	0-125*	125	Auto	Zinc	8.5	10 21/64	3 1/32	386.00

*Also available 0-25 PSI, 2-60 PSI, 2-250 PSI



COMPRESSORS

FILTERS/REGULATORS & LUBRICATORS (GAUGE INCLUDED)

- High-flow capacity reduces costly pressure drop
- Compact size allows greater design flexibility
- Lightweight construction for ease of installation

TOPRING

Model No.	NPT Size"	Max SCFM @ 100 PSI	Max PSI	Reduced Pressure Range PSI	Max Temp. °F	Drain Type	Bowl Type	Bowl Cap. oz.	H"	W"	Price /Each
COMPACT MODULAR DESIGN, 5-MICROMETRES FILTRATION											
TA719	1/4	31	150	0-125	125	Manual	Polyurethane Plast	1.5	7 1/16	3 3/16	267.00
TA720	1/4	31	150	0-125	125	Auto	Polyurethane Plast	1.5	7 1/16	3 3/16	325.00
TA723	1/4	38	150	0-125	125	Manual	Polyurethane w/guard	3.8	8 1/16	4 23/64	422.00
TA724	1/4	38	150	0-125	125	Auto	Polyurethane w/guard	3.8	8 1/16	4 23/64	475.00
STANDARD DUTY MODULAR DESIGN, 5-MICROMETRES FILTRATION											
TA735	1/2	110	150	0-125*	125	Manual	Polyurethane w/guard	8.5	10 21/64	5 3/8	506.00
TA736	1/2	110	150	0-125*	125	Auto	Polyurethane w/guard	8.5	10 21/64	5 3/8	562.00
TA739	3/4	125	150	0-125*	125	Manual	Polyurethane w/guard	8.5	10 21/64	6 1/16	506.00
TA740	3/4	125	150	0-125*	125	Auto	Polyurethane w/guard	8.5	10 21/64	6 1/16	562.00

*Also available 0-25 PSI, 0-60 PSI, 0-250 PSI



TA719

REGULATORS (GAUGE INCLUDED)

- High performance
- Compact design allows for greater design flexibility
- **Heavy-Duty:** High-capacity performance featuring rugged design for the most demanding applications

TOPRING

Model No.	NPT Size"	Max SCFM @ 100 PSI	Max PSI	Reduced Pressure Range PSI	Max Temp. °F	Bowl Type	H"	W"	Price /Each
HEAVY-DUTY									
BT861	3/4	300	300	5-250	125	Zinc	10 1/32	4 11/16	386.00
TA670	1	400	300	0-125	125	Zinc	10 7/16	4 11/16	386.00
TA672	1 1/2	500	300	0-125	125	Zinc	10 11/32	4 15/16	524.00



BT861

LUBRICATORS

- High performance over a wide flow range
- Easy maintenance
- Compact size

Model No.	NPT Size"	Max SCFM @ 100 PSI	Max PSI	Max Temp. °F	Bowl Type	Bowl Cap. oz.	H"	W"	Price /Each
COMPACT MODULAR DESIGN									
TA677	1/4	15	150	125	Polyurethane w/guard	3.8	6 15/16	2 3/16	180.00
TA679	3/8	80	150	125	Polyurethane w/guard	3.8	6 15/16	2 3/16	180.00
TA681	1/2	80	150	125	Polyurethane w/guard	3.8	6 15/16	2 3/16	180.00
STANDARD DUTY MODULAR DESIGN									
TA683	1/2	110	150	125	Polyurethane w/guard	8.5	8 9/16	2 11/16	206.00
TA684	1/2	110	250	150	Zinc	8.5	8 9/16	2 11/16	243.00
TA685	3/4	125	150	125	Polyurethane w/guard	8.5	8 9/16	3 1/32	206.00
TA686	3/4	125	250	150	Zinc	8.5	8 9/16	3 1/32	243.00



TA677

TA684

MAXDRAIN ELECTRONIC AUTOMATIC DRAINS

- Cost effective solution for regular, reliable condensation removal
- Fully automatic
- No maintenance
- Adjustable interval and discharge time
- Valve opens 0.5 to 10 seconds in 0.5 to 45 minute cycle times
- Test switch - for routine inspection and depressurization
- Solid-state timer for long life and reliability

Model No.	Mfg. No.	Inlet	Price/Each
WITH STRAINER AND VALVE			
TGA424	59.345	1/2 (M) NPT" and 1/4 (F) NPT"	142.00



ASME AIR SAFETY VALVES

- Designed to protect air compressor tanks and other unfired pressure vessels by exhausting when the maximum pressure is reached
- High quality, corrosion-resistant
- In accordance to ASME code and OSHA approved



TOPRING



Model No.	Pressure ±3% PSI	Flow Cap. SCFM	Price /Each
TA803	50	47	22.50
TA804	75	66	22.50
TA805	115	96	22.50
TA806	125	103	22.50
TA807	140	115	22.50

Model No.	Pressure ±3% PSI	Flow Cap. SCFM	Price /Each
TA808	155	126	22.50
TA809	163	132	22.20
TA810	190	152	22.50
TA811	200	160	22.50

STANDARD DUTY DESICCANT SYSTEMS

The standard duty desiccant system offers the same benefits as the heavy-duty system, but is designed for less frequent use. It is also a 3-stage system engineered to provide high quality air. It removes dirt, water, oil, and uncondensed moisture from compressed air lines. Very efficient at protecting expensive and sensitive air tools. Does not require electricity or refrigerants to provide extremely dry compressed air. Silica gel provides maximum absorption, which can be monitored through a small sight glass. When the blue gel turns pink, the gel is then saturated with water and should be replaced with fresh gel to allow the system to remain effective. System consists of a filter (5 micrometres) with auto drain, coalescing filter (0.1 micrometres) with auto drain, desiccant dryer, filter/regulator with gauge, and a safety slide valve.

SPECIFICATIONS

Max. Working Pressure:	175 PSI
Port Size:	1/2" NPT
Air Flow Capacity:	20 SCFM

3 STAGE FILTRATION:

1. Integral filter/regulator removes particulates down to 5 micrometres in size, to protect the regulator, which then reduces the pressure to the desired pressure setting
2. Coalescing filter removes 99.99% of oil aerosols and microscopic particles down to 0.1 micrometres in size
3. Desiccant dryer removes all remaining water vapour and a 40 micrometre filter element removes traces of any desiccant dust before it leaves the system

Model No.	Description	Price /Each
TG132	3-stage standard duty desiccant system	861.00

TOPRING



WATER SEPARATORS

- Cost effective way of ensuring that bulk water is removed from compressed air
- Ideal as a first treatment step between the compressor and receiver tank
- Requires no electricity and almost no maintenance
- Uses centrifugal force to remove up to 99% of bulk water
- Very low maintenance costs
- Simple and easy to install
- Efficient automatic drain
- Robust Aluminum body
- Maximum working pressure 232 PSI

TOPRING



Model No.	Mfg. No.	Pipe Connection" (F) NPT"	Flow Capacity SCFM	Weight lb.	Dimensions (in)		Price /Each
					Diameter	Height	
TLV335	56.010	1/2	88	2.4	3.42	8.23	436.00
TLV336	56.020	3/4	144	3.1	3.42	10.98	459.00
TLV337	56.030	1	232	8.4	5.12	12.4	559.00
TLV338	56.040	1 1/2	373	9.3	5.12	16.34	693.00
TLV339	56.050	1 1/2	488	10.6	5.12	20.28	786.00
TLV340	56.060	1 1/2	600	13.7	5.12	28.15	1088.00



TOOLS THAT MEASURE UP!

AURORA
TOOLS



REINFORCED CUT-OFF WHEELS

Typical Applications

- Cutting sheet metal
- Cutting pipe
- Foundry/forge shops – gate/riser removal, cutting forgings
- Metal plate dimensioning
- Ship building – metal fabrication
- Tool room – cutting drill bits, steel bar, tubing, metallurgical sectioning
- Construction – concrete/masonry work

To be used with:

- Portable grinder small diameter (2" - 4")
- Right angle grinder (4" - 9")
- Circular saw (6" - 8")
- High-speed gas/electric saw (12" - 16")
- Stationary machine large diameter (10" - 30")
- Chop saw (10" - 16")

NORZON PLUS TYPE 01

- Patented Norton SG (ceramic alumina)/ NorZon (zirconia alumina) grain combination
- Highly advanced bond system
- State-of-the-art manufacturing
- NorZon Plus: Up to 3x life versus aluminum oxide wheels on carbon steel, stainless and cast iron, 40% faster cut rate versus standard aluminum oxide wheels
- Superior wheel balance



NORTON

Model No.	Mfg. No.	D"	x	Size T"	x	A"	Max RPM	Price /Each
NS138	C0303514NZP	3	x	1/32	x	1/4	25 465	7.08
NS139	C0303538NZP	3	x	1/32	x	3/8	25 465	7.65
NS140	C0311614NZP	3	x	1/16	x	1/4	25 465	7.65
NS142	C0311638NZP	3	x	1/16	x	3/8	25 465	7.74
NS145	C031838NZP	3	x	1/8	x	3/8	25 465	8.79
NR003	C0403538NZP	4	x	1/32	x	3/8	19 100	9.90
NR005	C0411638NZP	4	x	1/16	x	3/8	19 100	9.90

GEMINI TYPE 01

- Advanced formulation
- Free cutting
- Maximizes the performance of conventional aluminum oxide abrasive
- Engineered to cut hard materials



NORTON

Model No.	Mfg. No.	D"	x	Size T"	x	A"	Max RPM	Price /Each
NS172	C0303514GFC	3	x	1/32	x	1/4	25 465	2.56
NS174	C0303538GFC	3	x	1/32	x	3/8	25 465	2.56
NS176	C0311614GFC	3	x	1/16	x	1/4	25 465	2.56
NS178	C0311638GFC	3	x	1/16	x	3/8	25 465	2.53
NS180	C031814GFC	3	x	1/8	x	1/4	25 465	3.93
NS182	C031838GFC	3	x	1/8	x	3/8	25 465	4.11
NS184	C0403514GFC	4	x	1/32	x	1/4	19 100	3.57
NS186	C0403538GFC	4	x	1/32	x	3/8	19 100	3.57
NS188	C0411614GFC	4	x	1/16	x	1/4	19 100	3.53
NS189	C0411638GFC	4	x	1/16	x	3/8	19 100	3.53
NS191	C041814GFC	4	x	1/8	x	1/4	19 100	4.93
NS192	C041838GFC	4	x	1/8	x	3/8	19 100	4.79

D x T x A: Diameter x Thickness x Arbor Size

ZIP™ TYPE 01

- Performance cutting and grinding with straight shaft and die grinders
- These wheels are formulated for high performance cutting, notching and grinding
- Made not to contaminate stainless steel
- Fast, cool and free cutting allowing the operator to work with minimal pressure for best control



WALTER
Surface Technologies

Model No.	Mfg. No.	D"	x	Size T"	x	A"	Grade	Max RPM	Price /Each
2"									
UE749	11-L-221	2	x	1/8	x	5/16	A-24-ZIP	31 000	6.50
UE751	11-L-231	2	x	1/4	x	5/16	A-24-ZIP	31 000	9.55
UE753	11-L-251	2	x	1/2	x	5/16	A-24-ZIP	31 000	14.30
TCU089	11-L-203	2	x	1/32	x	3/8	A-60-ZIP	30 600	5.95
UE748	11-L-213	2	x	1/16	x	3/8	A-24-ZIP	31 000	6.15
UE750	11-L-223	2	x	1/8	x	3/8	A-24-ZIP	31 000	6.50
UE752	11-L-233	2	x	1/4	x	3/8	A-24-ZIP	31 000	9.55
UE754	11-L-253	2	x	1/2	x	3/8	A-24-ZIP	31 000	14.30
3"									
UE755	11-L-302	3	x	1/32	x	1/4	A-60-ZIP	25 470	6.15
UE756	11-L-312	3	x	1/16	x	1/4	A-24-ZIP	25 470	6.50
UE758	11-L-322	3	x	1/8	x	1/4	A-24-ZIP	25 470	7.35
TE280	11-L-303	3	x	1/32	x	3/8	A-60-ZIP	25 470	6.15
UE757	11-L-313	3	x	1/16	x	3/8	A-24-ZIP	25 470	6.50
UE759	11-L-323	3	x	1/8	x	3/8	A-24-ZIP	25 470	7.35
UE760	11-L-333	3	x	1/4	x	3/8	A-24-ZIP	25 470	10.50
UE761	11-L-353	3	x	1/2	x	3/8	A-24-ZIP	25 470	15.30
4"									
UE762	11-L-403	4	x	1/32	x	3/8	A-60-ZIP	19 100	7.00
UE764	11-L-413	4	x	1/16	x	3/8	A-24-ZIP	19 100	7.00
UE766	11-L-423	4	x	1/8	x	3/8	A-24-ZIP	19 100	7.70
UE767	11-L-433	4	x	1/4	x	3/8	A-24-ZIP	19 100	12.10
UE763	11-L-405	4	x	1/32	x	5/8	A-60-ZIP	19 100	7.00
UE765	11-L-415	4	x	1/16	x	5/8	A-24-ZIP	19 100	7.00

PREMIUM 2 IN 1 THINCUT

- Superior comfort and performance
- Offers a fast, cool and burr free cut
- Free cutting reduces workload and increases productivity
- Highly reinforced cutting wheel
- For use on steel & stainless steel



TYROLIT

Model No.	Mfg. No.	D"	x	Size T"	x	A"	Max RPM	Price /Each
TYPE 01								
NU404	384142	4 1/2	x	0.045	x	7/8	13 300	3.44
NU405	384143	5	x	0.045	x	7/8	12 250	3.52
NU406	401205	6	x	0.045	x	7/8	10 200	5.58
TYPE 27								
NU554	34042238	4 1/2	x	0.045	x	7/8	13 300	4.23
NU397	34042239	5	x	0.045	x	7/8	12 250	3.52
NU408	34042240	6	x	0.045	x	7/8	10 200	4.44

CUBITRON™ 3 CUT-OFF WHEEL

- Creates perpendicular cuts using the outer edge of the wheel, making them ideal for cutting through metal, including autobody or marine sheet metal, stainless steel tubing, exhaust pipes, clamps, rusted fasteners, and more
- Delivers up to 10% increased cut rate compared to 3M™ Cubitron™ II Performance Abrasives to help reduce the amount of time and pressure required to get the job done
- Removes up to 3x more material compared to 3M™ Cubitron™ II Performance Abrasives
- Designed to last longer than leading competitors
- Uses Re-Engineered Precision Shaped Grain, a breakthrough proprietary molecular bonding technology designed with sharp, angular structures that continuously fracture to form sharp points to wear evenly, run cool, and optimize mineral breakdown
- Abrasive Material: Ceramic
- Bond Type: Resin
- Shelf Life: 1095 Days
- Grit: 36+



Model No.	Mfg. No.	D"	x	Size T"	x	A"	Max RPM	Price /Each
TYPE T27								
NV550	7100304008	4-1/2	x	0.045	x	7/8	13300	6.71
NV553	7100304009	4-1/2	x	1/8	x	7/8	13300	11.09
NV551	7100304010	5	x	0.045	x	7/8	12250	7.86
NV552	7100304011	5	x	0.09	x	7/8	12250	8.36
NV555	7100313191	7	x	0.09	x	7/8	8500	15.41

3M™ SILVER CUT-OFF WHEEL

- Ceramic cut-off wheel that is designed to cut quickly through all types of metals
- Optimized for use on carbon steel and stainless steel
- 3M™ Precision-Shaped Ceramic Grain cuts fast and cool
- No plowing
- Abrasive Material: Ceramic



Model No.	Type	D"	x	Size T"	x	A"	Max RPM	Price /Each
NV202	1	4-1/2	x	0.040	x	7/8	13300	3.71
NV203	1	4-1/2	x	0.045	x	7/8	13300	3.71
NV204	1	5	x	0.045	x	7/8	12250	4.23
NV205	1	6	x	0.045	x	7/8	10200	6.39
NV206	1	7	x	0.045	x	7/8	8500	7.40
NV207	27	4-1/2	x	0.045	x	7/8	13300	3.71
NV208	27	5	x	0.045	x	7/8	12250	4.23
NV209	27	6	x	0.045	x	7/8	10200	6.39

ZIPCUT™

- Cut faster, freer and cooler, requiring less power than standard thin cut-off wheel
- Heavily reinforced for extra safety and very flexible and resilient to resist twisting and bending
- Zipcut™ with integrated rib design
- Raised ribs reduces friction surface
- Air cooling action for cooler cutting
- Increased rigidity for straighter cuts



Model No.	Mfg. No.	D"	x	Size T"	x	A"	Grade	Max RPM	Price /Each
TYPE 01									
VV150	11-T-042	4 1/2	x	3/64	x	7/8	A-60-ZIP	13300	6.45
VV151	11-T-052	5	x	3/64	x	7/8	A-60-ZIP	12200	6.59
VV152	11-T-062	6	x	3/64	x	7/8	A-60-ZIP	10200	9.50
VV154	11-T-072	7	x	1/16	x	7/8	A-30-ZIP	8600	12.10
TYPE 27									
NS766	11-T-142	4 1/2	x	3/64	x	7/8	A-60-ZIP	13300	6.75
NS767	11-T-152	5	x	3/64	x	7/8	A-60-ZIP	12200	7.45
NS768	11-T-162	6	x	3/64	x	7/8	A-60-ZIP	10200	10.10

D x T x A: diameter x thickness x arbor size

ZIP™ STAINLESS

- Superior cutting of nickel alloyed steels
- These extra thin cut-off wheels cut all stainless steels fast, free and cool for burr-free finishes
- Will not contaminate stainless steel
- Type 01:** Specially designed for stainless steel fabricators; extra fast cutting of pipes or solids
- Type 27:** Allows more clearance for flush cutting; metal hub cladding for extra strength, control and safety



Model No.	Mfg. No.	D"	x	Size T"	x	A"	Grade	Max RPM	Price /Each
TYPE 01									
NS771	11-F 042	4 1/2	x	3/64	x	7/8	A-60-SS-ZIP	13300	6.40
NS772	11-F 052	5	x	3/64	x	7/8	A-60-SS-ZIP	12200	7.00
NS773	11-F 062	6	x	3/64	x	7/8	A-60-SS-ZIP	10200	9.35
NS774	11-F 072	7	x	1/16	x	7/8	A-30-SS-ZIP	8600	11.90
NS775	11-F 092	9	x	5/64	x	7/8	A-30-SS-ZIP	6800	16.00
TYPE 27									
NS776	11-F 142	4 1/2	x	3/64	x	7/8	A-60-SS-ZIP	13300	6.80
NS777	11-F 152	5	x	3/64	x	7/8	A-60-SS-ZIP	12200	7.35
NS778	11-F 162	6	x	3/64	x	7/8	A-60-SS-ZIP	10200	9.95
NS779	11-F 172	7	x	1/16	x	7/8	A-30-SS-ZIP	8600	12.40
NS780	11-F 192	9	x	5/64	x	7/8	A-30-SS-ZIP	6800	17.20

COMBO ZIP™

- 5/64" thickness allows for cutting and light grinding/deburring
- Wheel is reinforced like a grinding wheel to bear the force of light lateral pressure
- Zip family formulation guarantees fast cutting time and long life
- Equipped with metal protective hub for extra strength, control and safety
- Can be used for notching, root pass cleaning and chamfering
- Type 27



Model No.	Mfg. No.	D"	x	Size T"	x	A"	Grade	Max RPM	Price /Each
VV470	11-T-842	4 1/2	x	5/64	x	7/8	A-60-COMBO ZIP	13300	6.80
VV471	11-T-852	5	x	5/64	x	7/8	A-60-COMBO ZIP	12200	7.65
VV472	11-T-862	6	x	5/64	x	7/8	A-60-COMBO ZIP	10200	10.20

ZIP+™

- Superior performance cutting
- Feature an integrated rib design for better rigidity, cooler cutting and straighter cuts
- Used daily by metal fabricators, maintenance departments, sheet metal shops, welding shops, mechanical contractors, equipment manufacturers, automotive shops, etc.
- Type 01:** Cut fast, cool and free allowing the operator to work with minimal pressure for best control
- Type 27:** Equipped with a metal hub cladding for extra strength, control and safety; the preferred wheel for flush cutting in confined spaces



Model No.	Mfg. No.	D"	x	Size T"	x	A"	Grade	Max RPM	Price /Each
TYPE 01									
VE484	11-T-242	4 1/2	x	1/16	x	7/8	A-46-ZIP	13300	6.25
VE485	11-T-252	5	x	1/16	x	7/8	A-46-ZIP	12200	7.10
VV651	11-T-262	6	x	1/16	x	7/8	A-46-ZIP	10200	9.55
TYPE 27									
VV087	11-T-453	4 1/2	x	1/16	x	7/8	A-46-ZIP	13300	7.00
VV088	11-T-503	5	x	1/16	x	7/8	A-46-ZIP	12200	7.75
VV089	11-T-603	6	x	1/16	x	7/8	A-46-ZIP	10200	10.30

ABRASIVES



A60PX POWER-XTREME CUT-OFF WHEEL

- Manufactured with the most advanced technology of grains, binds and reinforcements to offer fast, cool, burn-free cutting of steel and stainless steel
- Specially designed technology ensures the longest life and best performance in its class
- Type 27 wheels allow more clearance for flush cutting applications



Model No.	Mfg. No.	D"	x	Size T"	x	A"	Max RPM	Price /Each
TYPE 01								
UAV969	501570	4 1/2	x	1/32	x	7/8	13 300	3.98
UAV971	501575	7	x	1/32	x	7/8	12 200	4.45
TYPE 27								
UAV974	501671	4 1/2	x	3/64	x	7/8	13 300	4.03
UAV975	501676	5	x	3/64	x	7/8	12 200	4.49
UAV976	501681	6	x	3/64	x	7/8	10 200	6.00

ZIP™ XX CERAMIC CUT-OFF WHEEL

- Smart Resin™ Technology exposes fresh grains at optimal time to optimize the balance between sharpness and life
- Experience faster, smoother and safer cutting
- Maximize productivity while reducing change-outs
- 100% self-sharpening ceramic grains
- Premium reinforcement for added safety
- Designed to exceed the highest industry safety standards
- Not only does it cut up to 10% faster than aluminum oxide wheels, it lasts at least 30% longer than competitive ceramic wheels



Model No.	Mfg. No.	D"	x	Size T"	x	A"	Grade	Max RPM	Price /Each
TYPE 01									
TCU068	11X242	4-1/2	x	1/16	x	7/8	46	13 300	7.25
TCU069	11X252	5	x	1/16	x	7/8	46	12 200	7.95
TCU070	11X262	6	x	1/16	x	7/8	46	10 200	10.80
TCU071	11X272	7	x	5/64	x	7/8	46	8600	13.50

A60T POWERPLUS CUT-OFF WHEEL

- Designed for high performance cutting of steel and stainless steel materials
- Made from highly refined ingredients; these Fe+S+Cl free wheels are specially formulated for cutting steel and contamination/burn free cutting of all stainless steels
- Fast, and cool cutting; these wheels allow the operator to work with minimal pressure for the best control
- Type 27 wheels allow more clearance for flush cutting applications



Model No.	Mfg. No.	D"	x	Size T"	x	A"	Max RPM	Price /Each
TYPE 27								
UAV972	501621	4 1/2	x	3/64	x	7/8	13 300	3.35
UAV973	501626	5	x	3/64	x	7/8	12 200	3.43

A46PX POWER-XTREME CUT-OFF WHEEL

- Manufactured with the most advanced technology of grains, binds and reinforcements to offer fast, cool, burn-free cutting of steel and stainless steel
- Specially designed technology ensures the longest life and best performance in its class



Model No.	Mfg. No.	D"	x	Size T"	x	A"	Max RPM	Price /Each
TYPE 01								
UAV970	501572	4-1/2	x	1/16	x	7/8	13 300	4.15

ZX46HP POWERPLUS CUT-OFF WHEEL

- Designed for high performance cutting of steel and stainless steel materials
- Fe+S+Cl free wheels are specially formulated for cutting steel and contamination/burn free cutting of all stainless steel
- Fast, and cool cutting; these wheels allow the operator to work with minimal pressure for the best control



Model No.	Mfg. No.	D"	x	Size T"	x	A"	Max RPM	Price /Each
TYPE 01								
UAV968	501537	7	x	1/16	x	7/8	8500	6.17

CANADA'S LEADING
MATERIAL HANDLING SUPPLIER

GEMINI RIGHTCUT

- Quality aluminum oxide grain
- Consistent performance at a competitive price
- Ideal for small jobs on a variety of metal applications from carbon to stainless steels
- Unique reinforcement design
- Provides safety, strength and straight cuts
- Extra thin
- Quick cutting action and low kerf loss
- Type 27



NORTON

Model No.	Mfg. No.	D"	x	Size T"	x	A"	Max RPM	Price /Each
NS093	RC45G27	4 1/2	x	3/64	x	7/8	13580	3.45
NS094	RC5G27	5	x	3/64	x	7/8	12225	4.11
NS096	RC7G27	7	x	1/16	x	7/8	8730	5.99

BLUEFIRE RIGHT ANGLE GRINDERS

- Upgraded zirconia alumina grain chemistry and shape, blended with premium aluminum oxide grain provides 2-3 times the life of aluminum oxide wheels
- Broad utility: from light- to heavy-pressure applications, on a wide range of materials: stainless steel, carbon steel, and alloys, to grey iron



NORTON

Model No.	Mfg. No.	D"	x	Size T"	x	A"	Max RPM	Price /Each
TYPE 01								
NR991	66252843208	4 1/2	x	0.045	x	7/8	13580	4.36
NO015	66252843209	5	x	0.045	x	7/8	12225	4.81
TYPE 27								
NR994	66252843219	4 1/2	x	1/16	x	7/8	13580	4.64
NO018	66252843220	5	x	0.045	x	7/8	12225	5.59

QUANTUM3™ RIGHTCUT™ CUT-OFF WHEEL

- 100% advanced ceramic alumina grain with a special shape for comfort and performance
- Unique bond system prevents premature grain released maximizing wheel life
- Great choice for stainless steel and carbon steel applications



NORTON

Model No.	Mfg. No.	D"	x	Size T"	x	A"	Max RPM	Price /Each
TYPE 01								
NV619	66252838454	4-1/2	x	0.045	x	7/8	13580	6.28
NV029	66252838455	4-1/2	x	1/16	x	7/8	13580	6.28
NV031	66252838460	5	x	0.045	x	7/8	12225	7.19
NV877	66252838462	5	x	1/16	x	7/8	12225	7.33
NV033	66252838465	6	x	1/16	x	7/8	10185	8.02
TYPE 27								
NV631	66252838456	4 1/2	x	1/16	x	7/8	13580	7.56
NV030	66252838457	4 1/2	x	1/16	x	5/8-11	13580	9.70
NV032	66252838464	5	x	1/16	x	7/8	12225	8.36
NV034	66252838466	6	x	1/16	x	7/8	10185	8.44

D x T x A: Diameter x Thickness x Arbor Size

TOUGH CUT™ TYPE 01

- Cut fast and free without binding to minimize the load on the tool and maintain high RPM for a clean cut and best all-around performance



WALTER
Surface Technologies

Model No.	Mfg. No.	D"	x	Size T"	x	A"	Grade	Max RPM	Price /Each
VV155	11-R-042	4 1/2	x	3/32	x	7/8	A-30	13 300	6.20
VV156	11-R-052	5	x	3/32	x	7/8	A-30	12 200	7.20
VV157	11-R-062	6	x	3/32	x	7/8	A-30	10 200	8.75
VV158	11-R-072	7	x	3/32	x	7/8	A-30	8600	10.20

CIRCULAR SAW REINFORCED CUT-OFF WHEELS



MASONRY & METAL TYPE 01

- Versatile, ideal for slotting and cutting when initial cost is a main consideration
- **Gemini all purpose:** Quality aluminum oxide abrasive, sets the aluminum oxide general purpose industry standard for cutting rough sides all material in metal fabrication applications
- **Norton masonry:** Sharp, silicon carbide grain, engineered for all masonry materials such as concrete, brick and asphalt
- **Norton metal:** Quality aluminum oxide abrasive, designed for cutting alloys, steels and ferrous metals



NORTON

Model No.	Mfg. No.	D"	x	Size T"	x	A"	Description	Max RPM	Price /Each
NS217	C0718M	7	x	1/8	x	DM*	Metal	8730	4.02
NS218	C0718MA	7	x	1/8	x	DM*	Masonry	8730	4.51
NS221	C0818M	8	x	1/8	x	DM*	Metal	7640	4.79
NS222	C0818MA	8	x	1/8	x	DM*	Masonry	7640	5.81

* DM: denotes diamond mount; 5/8" hole bushing included

ZIP CUT™ TYPE 01

- Cut faster, freer and cooler, requiring less power than standard thin cut-off wheels
- Heavily reinforced for extra safety and very flexible and resilient to resist twisting and bending



WALTER
Surface Technologies

Model No.	Mfg. No.	D"	x	Size T"	x	A"	Grade	Max RPM	Price /Each
VV153	11-T-070	7	x	1/16	x	5/8	A-30-ZIP	8600	12.10
VE482	11-T-080	8	x	1/16	x	5/8	A-30-ZIP	7600	13.60

ABRASIVES



CUT & GRIND WHEEL

- Designed to be a cost-effective solution that doesn't compromise on performance
- Made with 3M Precision Shaped Grain Technology, providing a super-sharp, micro-replicated abrasive
- Cuts fast and stays sharper, longer than conventional grinding wheels
- Grinds with less pressure, helping to reduce operator fatigue
- Engineered for a long performance life
- Can function as both a depressed centre grinding wheel and cut-off wheel
- Type: 27



Model No.	Mfg. No.	D"	x	Size T"	x	A"	Abrasive Material	Price /Each
TCS990	7100214084	4-1/2	x	1/8	x	7/8	Ceramic	6.14
TCS991	7100214086	5	x	1/8	x	7/8	Ceramic	6.79
TCS992	7100219761	6	x	1/8	x	7/8	Ceramic	13.23
TCS993	7100219187	7	x	1/8	x	7/8	Ceramic	14.50

QUANTUM3™ GRINDING & CUTTING WHEEL

- Ideal for stainless steel and carbon steel applications
- Advanced grain with a special shape for comfort and performance
- Unique bond system prevents premature grain release, maximizing wheel life
- Designed for off hand stock removal, smoothing welds and beveling, 90° grinding and pipe notching
- Abrasive Material: Ceramic Alumina
- Type: 27
- Grit: 24



Model No.	Mfg. No.	D"	x	Size T"	x	A"	Max. RPM	Price /Each
NY035	66252839427	6	x	1/8	x	5/8-11	10 185	19.10
NY036	66252839428	6	x	1/8	x	7/8	10 185	17.30
NY037	66252839429	7	x	1/8	x	5/8-11	8600	21.00
NY038	66252839430	7	x	1/8	x	7/8	8600	18.30
NY039	66252839431	9	x	1/8	x	5/8-11	6600	26.80
NY040	66252839432	9	x	1/8	x	7/8	6600	23.50

CERABOND X COMBINATION WHEEL

- New structure of ceramic grain provides users with never before seen grinding speed
- Combination of new bonding system and ceramic grain allows the wheel to stay sharp until the end
- Offers extreme lifetime, resulting in less wheel changes
- Ideal for cutting, fitting, light grinding and root pass grinding in steel and stainless steel
- Abrasive Material: Ceramic
- Type: 27
- Grit: 24



Model No.	Mfg. No.	D"	x	Size T"	x	A"	Max RPM	Price /Each
NV611	34401827	4 1/2	x	5/32	x	7/8	13 300	9.72
NV613	34401843	6	x	5/32	x	7/8	10 200	15.10
NV614	34401849	7	x	5/32	x	7/8	8600	17.30

SEE PAGES 770-771 FOR CORDLESS GRINDERS



D x T x A: Diameter x Thickness x Arbor Size

CHOP SAW REINFORCED CUT-OFF WHEELS



BLUEFIRE CHOP SAW WHEELS

- Upgraded zirconia alumina grain chemistry and shape, blended with premium aluminum oxide grain provides 2-3 times the life of aluminum oxide wheel.
- Broad utility: from light to heavy pressure applications, on a wide range of materials: stainless steel, carbon steel and alloys, to gray iron
- Excellent performance-to-price ratio lowers total grinding costs
- **Long Life:** Side reinforced; ideal for small cross-section work pieces, resist breakage and provide straight cuts
- **Rapid Cut:** Centrally reinforced, non-binding, free-cutting, rough sides, burr- and burr-free cuts



NORTON

Model No.	Mfg. No.	Additional Description	D" x T" x A"	Size	Max RPM	Price /Each
NO021	66252843250	Rapid Cut / Long Life	12 x 7/64 x 1	12 x 3/32 x 1	5095	17.60
NR996	66252843253	Long Life	14 x 7/64 x 1	14 x 3/32 x 1	4365	22.70
NO010	66252843254	Rapid Cut	14 x 7/64 x 1	14 x 3/32 x 1	4365	26.10
NR987	66252843257	Long Life	16 x 7/64 x 1	16 x 3/32 x 1	3820	33.20

GEMINI TYPE 01

- **Free Cut:** side reinforced; engineered for larger cross-sections and/or hard-to-cut materials, resist breakage and provide straight cuts
- **Long Life:** side reinforced; ideal for small cross-section work pieces, resist breakage and provide straight cuts
- **Rapid Cut:** centrally reinforced; free cutting, non-binding; burr- and burn-free cuts rough sides
- **Aluminum:** specially formulated bond for aluminum and other soft, nonferrous metals, no wax or rubber fillers; free cutting, resists loading, no surface contamination



NORTON

Model No.	Mfg. No.	Additional Description	D" x T" x A"	Size	Max RPM	Price /Each
GEMINI LONG LIFE						
NS255	C010764G		10 x 3/32 x 1	10 x 3/32 x 1	6110	12.50
NS256	C012764G		12 x 3/32 x 1	12 x 3/32 x 1	5095	10.20
NS259	C014764GLL		14 x 3/32 x 1	14 x 3/32 x 1	4365	12.80
NS261	C016764G		16 x 3/32 x 1	16 x 3/32 x 1	3820	22.40
GEMINI RAPID CUT						
NS260	C014764GRC		14 x 3/32 x 1	14 x 3/32 x 1	4365	11.70
GEMINI ALUMINUM						
NS258	C014764GALU		14 x 3/32 x 1	14 x 3/32 x 1	4365	18.00

BASIC TYPE 01

- All purpose, thin or heavy gauge cutting
- Centre-reinforced for fast cutting
- Non glazing on thin or heavy gauges
- For use on steel & stainless steel



TYROLIT

Model No.	Mfg. No.	Additional Description	D" x T" x A"	Size	Max RPM	Price /Each
NU402	20041210		14 x 3/32 x 1	14 x 3/32 x 1	4400	11.31

D x T x A: Diameter x Thickness x Arbor Size

CHOPCUT™ TYPE 01

- These wheels have been specifically developed for use on portable abrasive chop saws
- They put minimum load on the motor and are therefore easy on the operator as well as on the saw
- **General purpose:** The wheel of choice for solids; fast cutting rate with long wheel life
- **High performance:** The wheel of choice for tubing and extrusions; optimized for use on low power chop saws reduces load on machine and creates less burr
- **Alu:** Fast and free cutting in all types of aluminum and non-ferrous metals; unique formulation which guarantees no clogging



WALTER
Surface Technologies

Model No.	Mfg. No.	Size	Grade	Max RPM	Price /Each
GENERAL PURPOSE					
VV160	10-Q-123	12 x 3/32 x 1	A-30-HC+	5200	11.50
VV161	10-Q-143	14 x 3/32 x 1	A-30-HC+	4400	15.70
VV162	10-Q-163	16 x 7/64 x 1	A-30-HC+	3800	30.20
HIGH PERFORMANCE					
VV163	10-P-123	12 x 3/32 x 1	A-30	5200	16.00
VV164	10-P-143	14 x 3/32 x 1	A-30	4400	20.30
VV165	10-P-163	16 x 7/64 x 1	A-30	3800	27.60
ALUMINUM					
VV166	10-L-123	12 x 3/32 x 1	A-30-ALU	5200	25.50
VV167	10-L-143	14 x 3/32 x 1	A-30-ALU	4400	33.30

14" ABRASIVE CHOP SAWS

- Powerful 15 Amp, 4.0 max. HP motor: Delivers maximum cutting performance in a wide variety of materials
- Large cutting capacity: Provides versatility for a wide range of cutting applications, up to 5" pipe
- 45° miter capacity with adjustable fence
- Quick adjust vise clamp: Allows clamp to be adjusted quickly when cutting different material sizes
- All ball bearing construction: Delivers maximum durability
- **Includes:** Chop saw, vise, abrasive wheel, hex wrench

Model No. TLV202
Mfg. No. 6177-20
Price/Each \$319.00

SPECIFICATIONS

Amperage: 15.0
Motor Horsepower: 4.0
No Load RPM: 3900
Blade Diameter: 14"
Tool Weight: 40.0 lbs.



Milwaukee

PERFORMANCE PLUS 14" CHOP SAWS

- Ball bearing induction motor
- Spark deflector for safe operation
- Quick release vise for holding workpiece, which allows cuts up to a 45° angle

Model No. WK772
Mfg. No. 8342
Price/Each \$239.00

SPECIFICATIONS

Amperage: 15.0
No Load RPM: 3750
Blade Diameter: 14"
Max. Depth of Cut: 4"
Max. Width of Cut: 7 1/4"
Tool Weight: 45.0 lbs.



KING
CANADA

ABRASIVES

HIGH SPEED REINFORCED CUT-OFF WHEELS

- **Universal arbor:** 1"/20-mm knock out arbor fits all gas and electric high speed saws, 20-mm bushing is pre-mounted into the 1" hole use as is for a 20-mm arbor or remove bushing for a 1" arbor (once bushing is removed, cannot be replaced)
- **Asphalt:** Special blend of extra coarse silicon carbide ideal for cutting asphalt, green concrete, wide range of aggregates and abrasive materials
- **Concrete:** Coarse grit silicon carbide ideal for cutting brick, block, concrete and other masonry products
- **Ductile:** Special blend of silicon carbide and aluminum oxide ideal for cutting ductile, cast iron pipe, concrete lined water pipes, sewer construction and heavy-duty PVC
- **Metalworking:** High performance aluminum oxide ideal for general purpose cutting of steel and stainless steel parts (rebar, steel pipe, structural steel, sheet metal, etc)



NORTON

Model No.	Mfg. No.	D"	x	T"	x	A	Max RPM	Price /Each
FOR ASPHALT								
NR147	70184672877	14	x	1/8	x	1"/20 mm	5400	16.40
FOR CONCRETE								
NR865	66252837839	12	x	1/8	x	1"/20 mm	6360	8.93
NR868	66252837842	14	x	1/8	x	1"/20 mm	5400	14.90
NS234	70184623029	16	x	1/8	x	1"/20 mm	4800	25.10
FOR DUCTILE								
NR866	66252837840	12	x	1/8	x	1"/20 mm	6360	9.45
NR869	66252837843	14	x	1/8	x	1"/20 mm	5400	15.90
FOR METALWORKING								
NR864	66252837838	12	x	1/8	x	1"/20 mm	6360	8.81
NR867	66252837841	14	x	1/8	x	1"/20 mm	5400	14.70

PORTACUT™ TYPE 01

- These premium wheels stand out as the most reliable cut-off wheels for all on-site cutting jobs
- Specially reinforced for added safety and formulated for an optimal cutting speed and wheel life ratio



WALTER
Surface Technologies

Model No.	Mfg. No.	D"	x	T"	x	A	Grade	Max RPM	Price /Each
FOR STEEL & CAST IRON									
VV168	11-A-121	12	x	1/8	x	20 mm STIHL	A-24	6300	18.30
VV169	11-A-122	12	x	1/8	x	7/8" partner	A-24	6300	18.30
VV170	11-A-123	12	x	1/8	x	1"	A-24	6300	18.30
VV171	11-A-141	14	x	1/8	x	20 mm STIHL	A-24	5400	28.70
VV172	11-A-142	14	x	1/8	x	7/8" partner	A-24	5400	28.70
VV173	11-A-143	14	x	1/8	x	1"	A-24	5400	28.70
FOR REINFORCED CONCRETE, DUCTILE IRON, PVC & OTHER PLASTIC PIPES									
VV174	11-D-121	12	x	1/8	x	20 mm STIHL	C-24	6300	18.30
VV175	11-D-122	12	x	1/8	x	7/8" partner	C-24	6300	18.30
VV176	11-D-123	12	x	1/8	x	1"	C-24	6300	18.30
VV177	11-D-141	14	x	1/8	x	20 mm STIHL	C-24	5400	28.70
VV178	11-D-142	14	x	1/8	x	7/8" partner	C-24	5400	28.70
VV179	11-D-143	14	x	1/8	x	1"	C-24	5400	28.70

D x T x A: Diameter x Thickness x Arbor Size

LARGE DIAMETER REINFORCED CUT-OFF WHEELS FOR STATIONARY SAWS



RIPCUT™ TYPE 01

- These wheels are formulated for use on stationary cut-off machines to make more and faster cuts
- **General purpose:** The most versatile wheel; cuts thin walled profiles to heavy solids; the preferred wheel for low power machines
- **High performance:** Cut most anything from thin wall shapes to solid shafts; fast and cool cutting, long wheel life
- **Stainless:** Specially formulated to cut all types of stainless and alloyed steels; fast and cool cutting with less burr and discoloration



WALTER
Surface Technologies

Model No.	Mfg. No.	D"	x	T"	x	A	Grade	Max RPM	Price /Each
GENERAL PURPOSE									
YC431	10-B-123	12	x	1/8	x	1"	A-24-FC	5100	22.40
VE489	10-B-143	14	x	1/8	x	1"	A-24-FC	4400	34.40
YC479	10-B-163	16	x	5/32	x	1"	A-24-FC	3800	46.90
VE490	10-B-183	18	x	3/16	x	1"	A-24-FC	3400	76.50
VE491	10-B-203	20	x	3/16	x	1"	A-24-FC	3000	88.50
HIGH PERFORMANCE									
VE493	10-A-123	12	x	1/8	x	1"	A-24-RIP	5100	24.00
VE494	10-A-143	14	x	1/8	x	1"	A-24-RIP	4400	36.50
TAV067	10-A-163	16	x	5/32	x	1"	A-24-RIP	3800	51.00
VE495	10-A-183	18	x	3/16	x	1"	A-24-RIP	3400	82.20
VE496	10-A-203	20	x	3/16	x	1"	A-24-RIP	3000	94.70
VE497	10-A-206	20	x	3/16	x	40 mm	A-24-RIP	3000	94.70
STAINLESS									
WN964	10-C-143	14	x	1/8	x	1"	A-36-SS	4400	38.50

GEMINI LARGE DIAMETER TYPE 01

- Quality aluminum; sets the aluminum oxide industry standard for cutting all oxide abrasive material in metal fabrication applications



NORTON

Model No.	Mfg. No.	D"	x	T"	x	A"	Max RPM	Price /Each
GEMINI FREE CUT								
NS242	C01418GFC	14	x	1/8	x	1	4365	28.10
NS244	C016532GFC	16	x	5/32	x	1	3820	38.50
NS246	C018532G	18	x	5/32	x	1	3015	65.30
NS247	C020532GFC	20	x	5/32	x	1	2710	64.40
NS249	C020316GFC	20	x	3/16	x	1	2710	71.60
GEMINI LONG LIFE								
NS241	C01218GLL	12	x	1/8	x	1	5095	19.30
NS243	C01418GLL	14	x	1/8	x	1	4365	28.10
NS245	C016532GLL	16	x	5/32	x	1	3820	38.50
NS248	C020532GLL	20	x	5/32	x	1	2710	65.00
NS250	C020316GLL	20	x	3/16	x	1	2710	70.90

DEPRESSED CENTRE GRINDING WHEELS

Typical Applications

- Metal fabrication
- Petrochemical maintenance
- All-weld grinding
- Shipbuilding
- Foundry – notching and removing gates and risers
- Pipeline – root pass grinding, pipe bevelling and repair
- Construction – masonry/concrete fabrication



NORZON PLUS TYPE 27

- Premium, combination of Norton SG (ceramic aluminum oxide) and NorZon (zirconia alumina)
- Up to 10 times the performance of aluminum oxide wheels
- Advanced bond system providing the fastest cutting zirconia wheel on the market; easy on the operator and equipment



NORTON

Model No.	Mfg. No.	D" x T" x A"	Size	Max RPM	Price /Each
FOR STEEL CUTTING/NOTCHING & LIGHT GRINDING					
NS053	DC4518NZP	4 1/2 x 1/8 x 7/8		13 580	12.40
NS054	DC518NZP	5 x 1/8 x 7/8		12 225	13.90
NS055	DC718NZP	7 x 1/8 x 7/8		8600	18.10
NS056	DC918NZP	9 x 1/8 x 7/8		6600	23.40
FOR STEEL GRINDING					
NS044	DC4514NZP	4 1/2 x 1/4 x 7/8		13 580	13.80
NS039	DC514NZP	5 x 1/4 x 7/8		12 225	15.90
NS059	DC614NZP	6 x 1/4 x 7/8		10 185	19.50
NS036	DC714NZP	7 x 1/4 x 7/8		8600	20.50
NS032	DC914NZP	9 x 1/4 x 7/8		6600	27.70

HP™ TYPE 27

- High performance grinding and cutting
- These wheels are formulated to give highest productivity, safety and operator comfort on all types of grinders – air grinders, electric grinders/sanders and portable high speed angle grinders.
- Exceptional performance in grinding down welds, preparing weld edges, deburring, shaping, cleaning and cutting
- The wheel of choice for steel
- **With Spin-On arbor:** Fast and easy changeover of wheel for minimum downtime; perfectly centred wheel each and every time for best performance
- **With 3/8" arbor, 1/8" thick:** Ideal for both cutting and light grinding work; hold their cutting edge longer to give you a cutting life beyond compare; equipped with an exclusive metal hub cladding for extra strength and control
- **With 3/8" arbor, 1/4" thick:** High performance wheels grind off metal faster; smooth grinding with an aggressive, controlled bite; extra long wheel life



WALTER
Surface Technologies

Model No.	Mfg. No.	D" x T" x A"	Grade	Max RPM	Price /Each
WITH SPIN-ON ARBOR – 1/8" HP COMBO					
VV403	08-B-452	4 1/2 x 1/8 x 5/8"-11	A-30-COMBO	13 300	6.20
VV404	08-B-502	5 x 1/8 x 5/8"-11	A-30-COMBO	12 200	6.95
WITH SPIN-ON ARBOR – 1/4" HP					
VV401	08-B-450	4 1/2 x 1/4 x 5/8"-11	A-24-HPS	13 300	6.95
VV402	08-B-500	5 x 1/4 x 5/8"-11	A-24-HPS	12 200	7.55
7/8" ARBOR					
VV082	08-B-462	4 1/2 x 1/8 x 7/8"	A-30-COMBO	13 300	6.20
VV083	08-B-512	5 x 1/8 x 7/8"	A-30-COMBO	12 200	6.95
VV084	08-B-602	6 x 1/8 x 7/8"	A-30-COMBO	10 200	9.05
VV085	08-B-712	7 x 1/8 x 7/8"	A-30-COMBO	8600	9.55
VV086	08-B-912	9 x 1/8 x 7/8"	A-30-COMBO	6800	13.30
VV074	08-B-460	4 1/2 x 1/4 x 7/8"	A-24-HPS	13 300	6.95
VV075	08-B-510	5 x 1/4 x 7/8"	A-24-HPS	12 200	7.55
VV076	08-B-600	6 x 1/4 x 7/8"	A-24-HPS	10 200	9.55
VV077	08-B-710	7 x 1/4 x 7/8"	A-24-HPS	8600	11.30
VV078	08-B-910	9 x 1/4 x 7/8"	A-24-HPS	6800	17.40

1/4" wheels to be used with flange TAV109, 1/8" wheels to be used with flange UG580

D x T x A: Diameter x Thickness x Arbor Size

BLUEFIRE TYPE 27

- Upgraded zirconia alumina grain chemistry and shape, blended with premium aluminum oxide grain provide 2-3 times the life of aluminum oxide wheels
- Broad utility: from light- to heavy-pressure applications, on a wide range of materials: stainless steel, carbon steel, and alloys, to gray iron
- Excellent performance-to-price ratio lowers total grinding costs
- Contaminate-free INOX wheels contain <0.1% iron, sulfur, or chlorine for rust-free and corrosion-free results; will not contaminate stainless steel
- Foundry wheels have zirconia alumina/silicon carbide abrasive and an exceptionally strong reinforcement structure



NORTON

Model No.	Mfg. No.	D" x T" x A"	Size	Max RPM	Price /Each
FOR STEEL CUTTING/NOTCHING & LIGHT GRINDING					
NR992	66252843212	4 1/2 x 1/8 x 7/8		13 580	6.68
NO016	66252843216	5 x 1/8 x 7/8		12 225	7.42
NO014	66252843202	6 x 1/8 x 7/8		10 185	10.10
NO031	66252843234	7 x 1/8 x 7/8		8600	11.20
NO020	66252843245	9 x 1/8 x 7/8		6600	17.30
FOR STEEL GRINDING					
NR981	66252843214	4 1/2 x 1/4 x 7/8		13 580	7.16
NO017	66252843218	5 x 1/4 x 7/8		12 225	8.17
NO005	66252843203	6 x 1/4 x 7/8		10 185	10.40
NO032	66252843236	7 x 1/4 x 7/8		8600	12.10
NR985	66252843247	9 x 1/4 x 7/8		6600	19.10

ALLSTEEL™ TYPE 27

- Our most versatile grinding wheel
- These grinding wheels are designed to deliver top performance when working on both steel and stainless steel
- They incorporate the latest developments in grain and bonding technology to lower your grinding costs
- Operator safety and comfort, fast removal rates and outstanding life are key features that will let you do more work in less time
- **1/8" thick:** Fastest cutting wheel in its class; cool and free cutting; resists bending and twisting for extra safety
- **1/4" thick:** Fast removal rates and cool grinding action for entire life of wheel; excellent comfort and handling; heavily reinforced for absolute safety



WALTER
Surface Technologies

Model No.	Mfg. No.	D" x T" x A"	Grade	Max RPM	Price /Each
VE808	08-C-452	4 1/2 x 1/8 x 7/8	A-30-AS	13 300	5.30
VE809	08-C-502	5 x 1/8 x 7/8	A-30-AS	12 200	5.85
VE810	08-C-602	6 x 1/8 x 7/8	A-30-AS	10 200	7.65
VE811	08-C-702	7 x 1/8 x 7/8	A-30-AS	8600	8.00
VE812	08-C-902	9 x 1/8 x 7/8	A-30-AS	6800	11.10
VE803	08-C-450	4 1/2 x 1/4 x 7/8	A-24-AS	13 300	6.45
VE804	08-C-500	5 x 1/4 x 7/8	A-24-AS	12 200	7.05
VE805	08-C-600	6 x 1/4 x 7/8	A-24-AS	10 200	8.75
VE806	08-C-700	7 x 1/4 x 7/8	A-24-AS	8600	9.60

ABRASIVES

NORTON METAL TYPE 27

- Quality aluminum oxide abrasive, ideal for grinding alloys, metals, steels and ferrous metals
- Ideal for on site and small unit job
- Type 27

NORTON



NORTON METAL GRINDING WHEELS

Model No.	Mfg. No.	D" x T" x A"	Size	Max RPM	Price /Each
FOR STEEL CUTTING/NOTCHING & LIGHT DEBURRING					
NR881	DC4518M	4 1/2 x 1/8 x 7/8		13 580	2.05
NR882	DC518M	5 x 1/8 x 7/8		12 225	2.62
NR883	DC718M	7 x 1/8 x 7/8		8600	4.57
FOR GRINDING					
NS130	DC4514M	4 1/2 x 1/4 x 7/8		13 580	2.34
NS132	DC514M	5 x 1/4 x 7/8		12 225	2.85
NS134	DC714M	7 x 1/4 x 7/8		8600	4.82

ALUMINUM TYPE 27

- Performance grinding and cutting in soft metals
- These wheels grind all types of aluminum and non-ferrous metals smoothly and at removal rates never thought possible
- The specially impregnated bonding of these wheels resists loading even when grinding very soft, pure aluminum
- They do not contain any waxes or lubricants and do not contaminate the material worked on – ground surfaces are therefore clean and ready for welding without further clean-up
- 1/8" Thick:** Formulated for cutting but may also be used for intermittent light grinding; fast and free cutting
- 1/4" Thick:** Fast removal rate and long wheel life; no logging in any type of aluminum



WALTER
Surface Technologies

Model No.	Mfg. No.	D" x T" x A"	Size	Grade	Max RPM	Price /Each
VV123	08-L-452	4 1/2 x 1/8 x 7/8		A-24-ALU	13 300	7.80
VV125	08-L-502	5 x 1/8 x 7/8		A-24-ALU	12 200	9.05
VV127	08-L-602	6 x 1/8 x 7/8		A-24-ALU	10 200	11.90
VV129	08-L-702	7 x 1/8 x 7/8		A-24-ALU	8600	13.00
VV124	08-L-450	4 1/2 x 1/4 x 7/8		A-24-ALU	13 300	9.40
VV126	08-L-500	5 x 1/4 x 7/8		A-24-ALU	12 200	10.60
VV128	08-L-600	6 x 1/4 x 7/8		A-24-ALU	10 200	15.60
VV130	08-L-700	7 x 1/4 x 7/8		A-24-ALU	8600	16.10

CUBITRON™ 3 DEPRESSED CENTRE GRINDING WHEEL

- Designed for heavy weld removal and other heavy-duty grinding applications on almost all materials — while being specially formulated for use on stainless steel, mild steel, and aerospace alloys
- Delivers up to 15% increased cut rate compared to 3M™ Cubitron™ II Performance Abrasives to help reduce the amount of time and pressure required to get the job done
- Removes up to 1.5x more material compared to 3M™ Cubitron™ II Performance Abrasives
- Designed to last longer than leading competitors
- Uses Re-Engineered Precision Shaped Grain, a breakthrough proprietary molecular bonding technology designed with sharp, angular structures that continuously fracture to form sharp points to wear evenly, run cool, and optimize mineral breakdown
- Must be used with ANSI-approved guard that fits the size of the wheel
- Type: T27
- Abrasive Material: Ceramic
- Bond Type: Resin
- Shelf Life: 1095 Days
- Grit: 36+

3M



Model No.	Mfg. No.	D" x T" x A"	Size	Max RPM	Price /Each
NY560	7100303965	4 x 1/4 x 3/8		15300	6.24
NY530	7100303966	4-1/2 x 1/4 x 7/8		13300	12.82
NY561	7100303967	5 x 1/4 x 7/8		12250	14.79
NY562	7100313193	6 x 1/4 x 7/8		10200	18.07
NY563	7100313198	7 x 1/4 x 7/8		8500	18.94
NY564	7100313202	9 x 1/4 x 7/8		6650	25.64
NY565	7100312968	4-1/2 x 1/4 x 5/8		13300	14.48
NY566	7100312965	7 x 1/4 x 5/8		8500	21.20
NY531	7100303964	4 x 1/4 x 5/8		15300	12.35

D x T x A: Diameter x Thickness x Arbor Size

3M™ SILVER GRINDING WHEEL

- Ceramic grinding wheel that is designed to grind quickly through all types of metals
- Optimized for use on carbon steel and stainless steel
- 3M™ Precision-Shaped Ceramic Grain grinds fast and cool
- No plowing
- Type: 27
- Abrasive Material: Ceramic

3M



Model No.	D" x T" x A"	Size	Max RPM	Price /Each
NV210	4 x 1/4 x 3/8		15 300	4.64
NV211	4 x 1/4 x 5/8		15 300	4.64
NV212	4-1/2 x 1/4 x 7/8		13 300	4.83
NV213	5 x 1/4 x 7/8		12 250	5.11
NV214	6 x 1/4 x 7/8		10 200	10.42
NV215	7 x 1/4 x 7/8		8500	11.61
NV216	9 x 1/4 x 7/8		6650	17.49

HP XX™ GRINDING WHEEL

- Exceptional grinding with less sweat
- Manufactured with productivity in mind these wheels will not only get the job done faster and last longer but are also easier to control requiring less pressure to do the same job
- Grain, bond and reinforcement are of the highest quality and each wheel is perfectly balanced for superior control in the most demanding applications
- Use them for removing welds, preparing weld edges, deburring, shaping or cleaning with powerful angle grinders and see for yourself how you can do more work in less time and with less sweat
- Exceptional grinding with less pressure and better control
- Outstanding life in both steel and stainless steel
- Wheels are balance-controlled within tolerances twice as strict for absolute safety



WALTER
Surface Technologies

Model No.	Mfg. No.	D" x T" x A"	Size	Grade	Max RPM	Price /Each
VV455	08-H-450	4 1/2 x 1/4 x 7/8"		A-24-AXX	13 300	7.89
VV456	08-H-500	5 x 1/4 x 7/8"		A-24-AXX	12 200	8.59
VV457	08-H-600	6 x 1/4 x 7/8"		A-24-AXX	10 200	11.90
VV458	08-H-700	7 x 1/4 x 7/8"		A-24-AXX	8600	12.90
WITH SPIN-ON ARBOR						
VV409	08-K-450	4 1/2 x 1/4 x 5/8"-11		A-20-X	13 300	9.49
VV410	08-K-500	5 x 1/4 x 5/8"-11		A-20-X	12 200	11.90

PREMIUM 2 IN 1 TYPE 27

- Offers comfort, high stock removal and long life
- Fast removal & operator comfort
- Used in various applications
- Exclusive blend of bonding & grain system
- For use on steel & stainless steel



TYROLIT

Model No.	Mfg. No.	D" x T" x A"	Size	Max RPM	Price /Each
NU410	5293	4 1/2 x 9/32 x 7/8		13 300	4.70
NU411	5313	5 x 9/32 x 7/8		12 250	4.70
NU412	5330	6 x 9/32 x 7/8		10 200	7.73

CONCRETE TYPE 27

- High performance grinding and cutting
- These wheels for use on portable angle grinders have multiple high strength reinforcement and a matched super tough bond for extra safety in tough grinding and cutting applications
- They are made for fast material removal and smooth grinding and cutting of concrete, masonry, stone and similar building materials
- **1/8" Thick:** Fast and free cutting; formulated for cutting but may also be used for intermittent light grinding
- **1/4" Thick:** Excellent control in demanding applications; extra hard silicon carbide grain for fast material removal and long wheel life



Model No.	Mfg. No.	D"	x	T"	x	A"	Grade	Max RPM	Price /Each
UE693	08-D-452	4 1/2	x	1/8	x	7/8	C-24	13 300	7.75
UE694	08-D-502	5	x	1/8	x	7/8	C-24	12 200	8.05
UE696	08-D-702	7	x	1/8	x	7/8	C-24	8600	10.80
UE698	08-E-450	4 1/2	x	1/4	x	7/8	C-24	13 300	9.00
UE699	08-E-500	5	x	1/4	x	7/8	C-24	12 200	9.90

BLUEFIRE DEPRESSED CENTER WHEELS

- Upgraded zirconia alumina grain chemistry and shape, blended with premium aluminum oxide grain provides 2-3 times the life of aluminum oxide wheel.
- Broad utility: from light to heavy pressure applications, on a wide range of materials: stainless steel, carbon steel and alloys, to grey iron
- Excellent performance-to-price ratio lowers total grinding costs
- Will not contaminate stainless steel



NORTON

Model No.	Mfg. No.	D"	x	T"	x	A"	Max RPM	Price /Each
FOR CUTTING/NOTCHING & LIGHT GRINDING								
NR989	66252843190	4 1/2	x	1/8	x	7/8	13 580	6.22
N0027	66252843194	5	x	1/8	x	7/8	12 225	7.05
N0030	66252843198	6	x	1/8	x	7/8	10 185	9.01
FOR GRINDING								
NR978	66252843192	4 1/2	x	1/4	x	7/8	13 580	6.51
N0004	66252843188	9	x	1/4	x	7/8	6600	16.90

FLEXCUT™ TYPE 27

- Premium performance flexible grinding wheel especially formulated to deliver superior performance on all ferrous and non-ferrous metals (steel, stainless steel, aluminum)
- Deep Diamond-Cut™ pattern and optimized formulation
- More flexibility
- Best handling on flat and curved surfaces
- Cooler grinding
- Better stock removal in all materials
- 4 1/2" and 5" Flexcut™ flexible grinding wheels with the unique Spin-on quick change mounting system for better comfort and maximum productivity
- Always use flange model UG580

Model No.	Mfg. No.	D"	x	A	Grade	Max RPM	Price /Each
VV411	15-L-453	4 1/2	x	5/8"-11	A-36-X-FLEX	13 300	11.30
VV412	15-L-456	4 1/2	x	5/8"-11	A-60-X-FLEX	13 300	11.30
VV413	15-L-460	4 1/2	x	5/8"-11	A-100-X-FLEX	13 300	11.30
VV414	15-L-503	5	x	5/8"-11	A-36-X-FLEX	12 200	12.40
VV415	15-L-506	5	x	5/8"-11	A-60-X-FLEX	12 200	12.40
VV416	15-L-510	5	x	5/8"-11	A-100-X-FLEX	12 200	12.40
UG128	15-L-602	6	x	5/8"-11	A-24-X-FLEX	10 200	15.60
UG129	15-L-603	6	x	5/8"-11	A-36-X-FLEX	10 200	15.60
UG130	15-L-606	6	x	5/8"-11	A-60-X-FLEX	10 200	15.60
VV139	15-L-702	7	x	7/8"	A-24-X-FLEX	8600	16.10
VV140	15-L-703	7	x	7/8"	A-36-X-FLEX	8600	16.10



D x T x A: Diameter x Thickness x Arbor Size
D x A: Diameter x Arbor Size

Control spills
with confidence



ABRASIVES

STAINLESS TYPE 27

- Superior grinding and cutting
- These wheels are excellent for use on all nickel alloyed steels in tough and demanding applications
- They hug the work piece for minimum bounce or vibration for controlled grinding and a smooth, high quality finish
- They are made with highly refined ingredients that will not contaminate stainless steel
- **1/8" thick:** High performance cutting and intermittent light grinding; maintain a superior cutting edge; cool cutting, excellent wheel life with superior control
- **1/4" thick:** Fast and cool stock removal; high performance and superior control in the most demanding grinding applications
- **With Spin-On arbor:** Fast and easy changeover of wheel for minimum downtime; perfectly centred wheel each and every time for best performance



Model No.	Mfg. No.	D" x T" x A	Size	Grade	Max RPM	Price /Each
WITH SPIN-ON ARBOR						
VV407	08-F-452	4 1/2 x 1/8 x 5/8"-11	A-30-SS	13 300	7.65	
VV408	08-F-502	5 x 1/8 x 5/8"-11	A-30-SS	12 200	8.20	
VV405	08-F-450	4 1/2 x 1/4 x 5/8"-11	A-30-SS	13 300	9.15	
VV406	08-F-500	5 x 1/4 x 5/8"-11	A-30-SS	12 200	9.95	
WITH 7/8" ARBOR						
VV114	08-F-462	4 1/2 x 1/8 x 7/8"	A-30-SS-COMBO	13 300	7.65	
VV115	08-F-512	5 x 1/8 x 7/8"	A-30-SS-COMBO	12 200	8.20	
VV116	08-F-602	6 x 1/8 x 7/8"	A-30-SS-COMBO	10 200	10.70	
VV117	08-F-702	7 x 1/8 x 7/8"	A-30-SS-COMBO	8 600	11.80	
VV109	08-F-460	4 1/2 x 1/4 x 7/8"	A-30-SS	13 300	9.20	
VV110	08-F-510	5 x 1/4 x 7/8"	A-30-SS	12 200	9.95	
VV111	08-F-600	6 x 1/4 x 7/8"	A-30-SS	10 200	12.80	
VV112	08-F-700	7 x 1/4 x 7/8"	A-30-SS	8 600	13.40	

PIPEFITTER™ GRINDING WHEEL

- Outstanding performer in pipeline construction
- These wheels are specially formulated and reinforced for grinding joint welds between passes in pipeline construction and pipe fabrication
- They do not contain iron, sulfur or chlorine (Fe, S, Cl) and will not contaminate stainless steel
- **3/32" Thick:** Thin for fast and free cutting and grooving; can also be used for cutting sheet metal
- **5/32" Thick:** Formulated for light grinding, cutting and notching
- **1/8" Thick:** Ideal for use with low power angle grinders; grind joint welds with ease; can be used for intermittent light grinding, facing and bevelling work



Model No.	Mfg. No.	D" x T" x A	Size	Grade	Max RPM	Price /Each
VV103	08-N-453	4 1/2 x 3/32 x 7/8	A-36-PIPE	13 300	7.30	
VV104	08-N-503	5 x 3/32 x 7/8	A-36-PIPE	12 200	7.95	
VV380	08-N-603	6 x 3/32 x 7/8	A-36-PIPE	10 200	9.80	
VV106	08-N-703	7 x 3/32 x 7/8	A-36-PIPE	8 600	10.80	
VV385	08-N-454	4 1/2 x 5/32 x 7/8	A-36-PIPE	13 300	7.30	
VV386	08-N-504	5 x 5/32 x 7/8	A-36-PIPE	12 200	7.95	
VV105	08-N-604	6 x 5/32 x 7/8	A-20-PIPE	10 200	11.40	
VV107	08-N-704	7 x 5/32 x 7/8	A-20-PIPE	8 600	13.00	
VV381	08-N-452	4 1/2 x 1/8 x 7/8	A-36-PIPE	13 300	7.30	
VV382	08-N-502	5 x 1/8 x 7/8	A-36-PIPE	12 200	7.95	
VV383	08-N-602	6 x 1/8 x 7/8	A-36-PIPE	10 200	9.80	
VV384	08-N-702	7 x 1/8 x 7/8	A-36-PIPE	8 600	11.40	

D x T x A: Diameter x Thickness x Arbor Size

ANGLE GRINDERS WITH TRIGGER GRIP

- Trigger grip handle provides better control, reach and leverage
- Debris baffles protect internal components by deflecting damaging debris out of the airflow at the intake vents
- External brush doors reduces service time by providing easy access to brushes
- Includes: Side handle, spanner wrench and type 27 guard
- Wheel Diameter: 5"
- Voltage: 120 V
- Amps: 11 A
- No Load RPM: 11 000
- Spindle Size: 5/8"
- Tool Weight: 5.6 lbs.

Model No. TLZ810
Mfg. No. 6121-31A
Price/Each \$209.00



HEAVY-DUTY ANGLE GRINDERS

- High power-to-weight ratio for greater efficiency and reduced user fatigue
- External brush doors for easy servicing
- Sealed ball and roller bearings for extended motor life
- Includes: Grinding wheel, wrench, keyless adjustable guard and two position side handle
- Wheel Diameter: 5"
- Voltage: 120 V
- Amps: 12 A
- No Load RPM: 10 000
- Spindle Size: 5/8"
- Tool Weight: 7.4 lbs.

Model No. VE980
Mfg. No. DW831
Price/Each \$165.00



AURORA
TOOLS

Celebrating
15
YEARS

EXCEEDING EXPECTATIONS

BENCH GRINDING WHEELS

Typical Applications

- Offhand deburring and sharpening of parts and tools



GEMINI

- Quality, grey aluminum oxide for metal general purpose applications and sharp, green silicon carbide for nonferrous applications
- Each wheel contains nested bushings, accommodates a wide variety of standard arbor sizes
- Economical prices; ideal for small job shops and numerous applications
- All wheels supplied with bushings



NORTON

Model No.	Mfg. No.	Size D" x T" x A"	Grit	Max RPM	Price /Each
ALUMINUM OXIDE WHEELS FOR STEEL APPLICATION					
NS320	36132	6 x 1/2 x 1	Coarse	4140	27.00
NS321	36131	6 x 1/2 x 1	Medium	4140	27.00
NS322	36133	6 x 1/2 x 1	Fine	4140	27.00
NS323	88245	6 x 3/4 x 1	Coarse	4140	31.50
NS324	88240	6 x 3/4 x 1	Medium	4140	31.50
NS325	88235	6 x 3/4 x 1	Fine	4140	31.50
NS326	88260	6 x 1 x 1	Coarse	3600	36.50
NS327	88255	6 x 1 x 1	Medium	3600	36.50
NS328	88250	6 x 1 x 1	Fine	3600	36.50
NS329	88275	7 x 1 x 1	Coarse	3600	44.50
NS330	88270	7 x 1 x 1	Medium	3600	44.50
NS331	88265	7 x 1 x 1	Fine	3600	44.50
NS332	88278	8 x 3/4 x 1	Coarse	3600	46.30
NS333	88277	8 x 3/4 x 1	Medium	3600	46.30
NS334	42317	8 x 3/4 x 1	Fine	3600	46.30
NS335	44454	8 x 1 x 1	Very coarse	3600	54.60
NS336	88286	8 x 1 x 1	Coarse	3600	54.60
NS337	88285	8 x 1 x 1	Medium	3600	54.60
NS338	88280	8 x 1 x 1	Fine	3600	54.60
NS339	60788	10 x 1 x 1	Very coarse	2485	86.70
NS340	88295	10 x 1 x 1	Coarse	2485	86.70
NS341	88290	10 x 1 x 1	Medium	2485	86.70
NS342	60350	10 x 1 x 1	Fine	2485	86.70
NS343	61250	10 x 1 1/4 x 1 1/4	Coarse	2485	101.00
NS344	61251	10 x 1 1/4 x 1 1/4	Medium	2485	101.00
NS345	61393	10 x 1 1/2 x 1 1/4	Coarse	2485	120.00
NS346	61395	10 x 1 1/2 x 1 1/4	Medium	2485	120.00
NS347	63052	12 x 1 1/2 x 1 1/2	Coarse	2070	164.00
NS348	63053	12 x 1 1/2 x 1 1/2	Medium	2070	164.00
NS349	63054	12 x 2 x 1 1/2	Very coarse	2070	214.00
NS350	63055	12 x 2 x 1 1/2	Coarse	2070	214.00
NS351	63056	12 x 2 x 1 1/2	Medium	2070	214.00

SILICON CARBIDE WHEELS FOR NON-STEEL APPLICATIONS

NS352	36571	6 x 1/2 x 1	Medium	4140	40.80
NS353	36572	6 x 1/2 x 1	Fine	4140	40.80
NS354	36573	6 x 1/2 x 1	Extra-fine	4140	40.80
NS355	37190	6 x 3/4 x 1	Medium	4140	48.60
NS356	37191	6 x 3/4 x 1	Fine	4140	48.60
NS357	37192	6 x 3/4 x 1	Extra-fine	4140	48.60
NS358	37187	6 x 1 x 1	Medium	3600	56.20
NS359	37193	6 x 1 x 1	Fine	3600	56.20
NS360	37194	6 x 1 x 1	Extra-fine	3600	56.20
NS361	42300	7 x 1 x 1	Medium	3600	70.10
NS362	42301	7 x 1 x 1	Fine	3600	70.10
NS363	42302	7 x 1 x 1	Extra-fine	3600	70.10
NS364	44087	8 x 1 x 1	Medium	3600	84.00
NS365	44534	8 x 1 x 1	Fine	3600	84.00
NS366	44535	8 x 1 x 1	Extra-fine	3600	84.00
NS367	44536	10 x 1 x 1 1/4	Medium	2485	136.00
NS368	60366	10 x 1 x 1 1/4	Fine	2485	136.00
NS369	63359	12 x 2 x 1 1/4	Medium	2070	351.00
NS370	63360	12 x 2 x 1 1/4	Fine	2070	351.00

Arbor bushings

These size bushings shipped free of charge with your Gemini wheel order

Wheel Diameter	Wheel Centre Hole	1/2"	5/8"	3/4"	7/8"	1"	1 1/4"
6", 7"	1"
8"	1"
10"	1 1/4"
12" x 1"	1 1/4"
12" x 2"	1 1/4"
12"	1 1/2"

BENCH & PEDESTAL GRINDING WHEELS

- For general purpose grinding work on bench and pedestal grinders
- Grits 24 and 36 for fast and rough grinding
- Grit 46 for intermediate requirements
- Grits 60 and 80 for a finer finish work
- All 6", 7", 8" and 10" wheels are supplied with nested reducer bushings to fit on 1", 3/4" and 1/2" shafts



Model No.	Mfg. No.	Size D" x T" x A"	Grit	Max RPM	Price /Each
VE775	12-E-324	6 x 3/4 x 1	36 Coarse	4100	43.40
VE776	12-E-325	6 x 3/4 x 1	46 Medium	4100	43.40
YB806	12-E-328	6 x 3/4 x 1	80 Fine	4100	43.40
VE777	12-E-344	6 x 1 x 1	36 Coarse	4100	51.90
VE778	12-E-345	6 x 1 x 1	46 Medium	4100	51.90
VE779	12-E-348	6 x 1 x 1	80 Fine	4100	51.90
VE780	12-E-444	7 x 1 x 1	36 Coarse	3600	64.40
VE781	12-E-447	7 x 1 x 1	80 Fine	3600	64.40
VE783	12-E-533	8 x 7/8 x 1	24 Coarse	3600	76.10
VE784	12-E-537	8 x 7/8 x 1	60 Fine	3600	76.10
VE785	12-E-543	8 x 1 x 1	24 Coarse	3600	77.80
VE786	12-E-545	8 x 1 x 1	46 Medium	3600	77.80
VE787	12-E-547	8 x 1 x 1	60 Fine	3600	77.80
VE788	12-E-553	8 x 1 1/4 x 1	24 Coarse	3600	92.50
VE789	12-E-557	8 x 1 1/4 x 1	60 Fine	3600	96.20
VE790	12-E-643	10 x 1 x 1	24 Coarse	3600	112.00
VE791	12-E-647	10 x 1 x 1	60 Fine	3600	112.00
YC465	12-E-657	10 x 1 1/4 x 1	60 Fine	3600	127.00

D x T x A: Diameter x Thickness x Arbor Size

10" BENCH GRINDERS

- 14 A, 110 V, single phase
- Wheel diameter: 10"
- 1720 RPM
- Weight: 80 lbs.
- Includes: Removable wheel covers, plastic eye shields and medium and coarse grinding wheels



Model No. TZ815
Mfg. No. KC-1090
Price/Each \$460.00



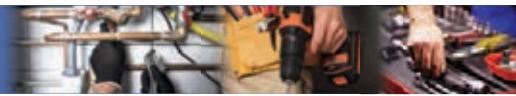

FLAP DISCS

Typical Applications

- Stock removal
- Deburring
- Blending welds
- Edge chamfering
- Rust removal
- Cleaning and finishing

769F QUICK CHANGE FLAP DISC

- Contains 3M precision-shaped grain, which cuts faster and lasts longer than conventional abrasive grain
- Individual flaps break down, exposing fresh mineral to deliver consistent cut rate for the life of the disc



Model No.	Mfg. No.	Grit	Size D" x A"	Abrasive Material	Max RPM	Price /Each
TYPE 27						
NV670	AB05903	40+	4-1/2 x 7/8"	Ceramic	13 300	5.75
NV648	AB05904	60+	4-1/2 x 7/8"	Ceramic	13 300	5.75
NV660	AB05905	80+	4-1/2 x 7/8"	Ceramic	13 300	5.75
NV659	AB05924	120+	4-1/2 x 7/8"	Ceramic	13 300	5.75
NV658	AB05915	40+	5 x 7/8"	Ceramic	12 000	7.68
NV653	AB05918	60+	5 x 7/8"	Ceramic	12 000	7.68
NV662	AB05919	80+	5 x 7/8"	Ceramic	12 000	7.68
NV651	AB05928	120+	5 x 7/8"	Ceramic	12 000	7.68
NV645	AB05940	40+	7 x 5/8"-11	Aluminum Oxide, Ceramic	8600	15.88
NV657	AB05941	60+	7 x 5/8"-11	Aluminum Oxide, Ceramic	8600	15.88
NV666	AB05942	80+	7 x 5/8"-11	Aluminum Oxide, Ceramic	8600	15.88
NV668	AB05909	40+	7 x 7/8"	Aluminum Oxide, Ceramic	8600	11.24
NV655	AB05910	60+	7 x 7/8"	Aluminum Oxide, Ceramic	8600	11.24
NV664	AB05911	80+	7 x 7/8"	Aluminum Oxide, Ceramic	8600	11.24
NV649	AB05926	120+	7 x 7/8"	Aluminum Oxide, Ceramic	8600	11.24

Model No.	Mfg. No.	Grit	Size D" x A"	Abrasive Material	Max RPM	Price /Each
TYPE 29						
NV654	AB05906	40+	4-1/2 x 7/8"	Ceramic	13 300	5.75
NV643	AB05907	60+	4-1/2 x 7/8"	Ceramic	13 300	5.75
NV652	AB05908	80+	4-1/2 x 7/8"	Ceramic	13 300	5.75
NV656	AB05925	120+	4-1/2 x 7/8"	Ceramic	13 300	5.75
NV647	AB05916	40+	5 x 7/8"	Ceramic	12 000	7.68
NV663	AB05917	60+	5 x 7/8"	Ceramic	12 000	7.68
NV625	AB05920	80+	5 x 7/8"	Ceramic	12 000	7.68
NV665	AB05929	120+	5 x 7/8"	Ceramic	12 000	7.68
NV661	AB05943	40+	7 x 5/8"-11	Aluminum Oxide, Ceramic	8600	15.88
NV646	AB05944	60+	7 x 5/8"-11	Aluminum Oxide, Ceramic	8600	15.88
NV644	AB05912	40+	7 x 7/8"	Aluminum Oxide, Ceramic	8600	11.24
NV669	AB05913	60+	7 x 7/8"	Aluminum Oxide, Ceramic	8600	11.24
NV650	AB05914	80+	7 x 7/8"	Aluminum Oxide, Ceramic	8600	11.24
NV667	AB05927	120+	7 x 7/8"	Aluminum Oxide, Ceramic	8600	11.24

POWERBLEND™ TRM QC TRIMMABLE FLAP DISC

- Premium high performance zirconia alumina grain blend ensures fast, cool cutting and extra-long life on steel and stainless steel
- The 5/8-11 "Quick Change" arbor increases productivity by reducing time spent on wheel change outs
- Type 27 wheel shape offers the most contact area to create a smooth, professional finish quickly and easily
- Trimmable backing pad for extended disc life
- Optimal performance when operated at an angle between 0° and 15°
- Abrasive Material: Zirconia Alumina



Model No.	Mfg. No.	Grit	Size D" x A"	Price /Each
UAV980	503565	4-1/2 x 5/8"-11	Z60	16.30
UAV981	503575	5 x 5/8"-11	Z60	20.40

D x A: Diameter x Arbor Size

QUICK TRIM SG BLAZE R980P – TYPE 27

- Latest-generation ceramic alumina abrasive grain and improved supersize grinding aid
- New orange, plastic back plate material
- Easily trimmable, the plastic wears away as the flap discs grind
- Durable Y-wt polyester flaps significantly improve life, grain retention, and fray resistance
- 1-step grinding and finishing
- Ideal for: Stock removal, edge chamfering, weld blending, deburring/deflashing, cleaning/finishing
- Best/highest productivity on stainless steel, titanium, and super alloys



Model No.	Mfg. No.	Size D" x A"	Grit	Max RPM	Price /Each
NR954	66254400253	4 1/2 x 7/8"	40	13 300	9.79
NR955	66254400254	4 1/2 x 7/8"	60	13 300	9.79
NR956	66254400255	4 1/2 x 7/8"	80	13 300	9.79
NR957	66254400256	4 1/2 x 7/8"	120	13 300	9.79
NR958	66254400262	5 x 7/8"	40	12 000	12.30
NR959	66254400264	5 x 7/8"	60	12 000	12.30
NR960	66254400265	5 x 7/8"	80	12 000	12.30
NR961	66254400519	5 x 7/8"	120	12 000	12.30
NR966	66254461059	7 x 7/8"	40	8600	19.00
NR967	66254461060	7 x 7/8"	60	8600	19.00
NR968	66254461061	7 x 7/8"	80	8600	19.00
NR969	66254461063	7 x 7/8"	120	8600	19.00
NR950	66254400257	4 1/2 x 5/8"-11	40	13 300	12.10
NR951	66254400258	4 1/2 x 5/8"-11	60	13 300	12.10
NR952	66254400259	4 1/2 x 5/8"-11	80	13 300	12.10
NR953	66254400261	4 1/2 x 5/8"-11	120	13 300	12.10
NR962	66254461066	7 x 5/8"-11	40	8600	23.70
NR963	66254461067	7 x 5/8"-11	60	8600	23.70
NR964	66254461068	7 x 5/8"-11	80	8600	23.70
NR965	66254461069	7 x 5/8"-11	120	8600	23.70

CUBITRON™ II 967A

- Ideal for a wide range of low to medium-high pressure applications
- Used for paint prep and stainless steel fabric where finish and gouge resistance are important
- Safe on stainless steel, carbon steel, aluminum and non-ferrous metals
- Grinding aid helps keep product cool on heat-sensitive metals
- All discs have Y-weight poly-cotton backing



Model No.	Mfg. No.	Size D" x A"	Grit	Max RPM	Price /Each
TYPE 27					
NU325	051141-55605	4 1/2 x 7/8"	40+	13 300	9.84
NU326	051141-55606	4 1/2 x 7/8"	60+	13 300	9.84
NU327	051141-55607	4 1/2 x 7/8"	80+	13 300	9.84
NU345	051125-86715	5 x 7/8"	40+	12 000	10.80
NU348	051125-86718	5 x 7/8"	60+	12 000	10.80
NU349	051125-86719	5 x 7/8"	80+	12 000	10.80
NU328	051141-55611	7 x 7/8"	40+	8600	19.28
NU329	051141-55612	7 x 7/8"	60+	8600	19.28
NU330	051141-55613	7 x 7/8"	80+	8600	19.28
TYPE 29					
NU331	051141-55623	4 1/2 x 7/8"	40+	13 300	9.84
NU332	051141-55624	4 1/2 x 7/8"	60+	13 300	9.84
NU333	051141-55625	4 1/2 x 7/8"	80+	13 300	9.84
NU346	051125-86716	5 x 7/8"	40+	12 000	10.80
NU347	051125-86717	5 x 7/8"	60+	12 000	10.80
NU350	051125-86720	5 x 7/8"	80+	12 000	10.80
NU334	051141-55629	7 x 7/8"	40+	8600	19.28
NU335	051141-55630	7 x 7/8"	60+	8600	19.28
NU336	051141-55631	7 x 7/8"	80+	8600	19.28

NEON R766 ALUMINUM OXIDE

- Great for difficult-to-grind material such as aluminum, brass, bronze, stainless, carbon steel and titanium
- Good-performing, economically priced, general purpose discs
- Longer life and faster cut rate
- High-strength, lightweight & absorbs vibration
- Plastic wears away as disc grinds, allowing for full use of flap
- **Type 27 flat face:** High flap density, flexible plastic back discs
- **Type 29 conical shape:** Standard flap density

NORTON



Model No.	Mfg. No.	Size D" x A"	Grit	Price /Each
TYPE 27				
NO083	66623399062	4 1/2 x 7/8	36	7.81
NO084	66623399063	4 1/2 x 7/8	40	7.81
NO085	66623399064	4 1/2 x 7/8	60	7.81
NO086	66623399212	5 x 7/8	40	7.85
NO087	66623399213	5 x 7/8	60	7.85
TYPE 29				
NO096	66623399175	4 1/2 x 7/8	120	6.51

NORTON METAL R828

- Quality zirconia alumina abrasive
- Strong engineered blend of X-wt cotton and Y-weight dark blue polyester flaps offers higher cut rate, longer life, and greater wear resistance
- Durable, fiberglass back offers strength, lightweight and absorbs vibration
- Available in both Type 29 conical for hard-to-grind materials and Type 27 flat for softer materials

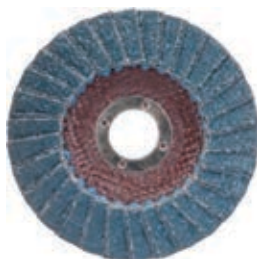

NORTON

Model No.	Mfg. No.	Size D" x A"	Grit	Max RPM	Price /Each
NORTON METAL TYPE 29 - FIBREGLASS PLATE					
NR148	66254419963	4 1/2 x 7/8	36	13 300	5.10
NR149	66254419978	4 1/2 x 7/8	40	13 300	5.10
NR150	66254419984	4 1/2 x 7/8	60	13 300	5.10
NR151	66254419987	4 1/2 x 7/8	80	13 300	5.10
NR152	66254419998	5 x 7/8	36	12 000	5.25
NR153	66254420001	5 x 7/8	40	12 000	5.25
NR154	66254420002	5 x 7/8	60	12 000	5.25
NR155	66254420003	5 x 7/8	80	12 000	5.25
NR157	66254420006	7 x 7/8	40	8600	11.10

POWERBLEND™ TRIMMABLE FLAP DISC

- These premium high performance zirconia grain discs ensure fast, cool cutting action and extra long life on steel and stainless steel
- Exceptional durability - outlasts traditional resin fibre discs up to 25 times
- The raised hub and polymer backing allows the operator to "trim" away the backing as the outside contact area of the abrasive flap is worn away
- The special polymer backing will not contaminate the work piece
- Ideal for a wide range of metal fabricating and finishing operations
- Abrasive Material: Zirconia Alumina
- Type: 29



JET

Model No.	Mfg. No.	Size D" x A"	Grit	Max RPM	Price /Each
UAV979	503423	5 x 7/8	240	12 250	11.50

D x A: Diameter x Arbor Size

ENDURO-FLEX™

The one step finishing disc

- One-step finishing discs not only meet but surpass the challenges that the metal fabricating and finishing industry faces daily
- Ultra sharp and refined zirconium grain stays sharper longer to remove more material faster
- Special top coat continuously cools and lubricates the disc for smooth, vibration-free grinding and sanding from start to finish
- **With Spin-On arbor:** Will not smear or contaminate the work piece; patented backing has now even more reinforcing ribs for added safety; packing can be trimmed down easily for a customized feel
- **With 7/8" arbor:** Quiet and vibration-free grinding; complete control and total operator comfort; will not smear or contaminate the work piece; flexible backing wears down without the nuisance dust often associated with fiberglass backed discs
- Always use flange model **UG580**



WALTER
Surface Technologies

Model No.	Mfg. No.	Size D" x A"	Grit	Max RPM	Price /Each
SPIN-ON ARBOR					
BZ653	06-B-454	4 1/2 x 5/8"-11	40	13 300	17.50
BZ654	06-B-456	4 1/2 x 5/8"-11	60	13 300	17.50
BZ655	06-B-458	4 1/2 x 5/8"-11	80	13 300	17.50
BZ656	06-B-462	4 1/2 x 5/8"-11	120	13 300	17.50
BZ657	06-B-504	5 x 5/8"-11	40	12 200	20.50
BZ658	06-B-506	5 x 5/8"-11	60	12 200	20.50
BZ659	06-B-508	5 x 5/8"-11	80	12 200	20.50
BZ660	06-B-512	5 x 5/8"-11	120	12 200	20.50
BZ661	06-B-604	6 x 5/8"-11	40	10 200	24.50
BZ662	06-B-606	6 x 5/8"-11	60	10 200	24.50
BZ663	06-B-608	6 x 5/8"-11	80	10 200	24.50
BZ664	06-B-612	6 x 5/8"-11	120	10 200	24.50
7/8" ARBOR					
TE229	15-R-454	4 1/2 x 7/8"	40	13 300	19.10
TE230	15-R-456	4 1/2 x 7/8"	60	13 300	19.10
TE231	15-R-458	4 1/2 x 7/8"	80	13 300	19.10
TE232	15-R-462	4 1/2 x 7/8"	120	13 300	19.10
TE233	15-R-504	5 x 7/8"	40	12 200	22.20
TE234	15-R-506	5 x 7/8"	60	12 200	22.20
TE235	15-R-508	5 x 7/8"	80	12 200	22.20
TE236	15-R-512	5 x 7/8"	120	12 200	22.20
TE237	15-R-704	7 x 7/8"	40	8600	38.70
TE239	15-R-708	7 x 7/8"	80	8600	38.70
TE240	15-R-712	7 x 7/8"	120	8600	38.70

STANDARD 2 IN 1 - TYPE 29

- Standard aggressive fiber backed Zirconium
- High removal rate
- For use on steel & stainless steel
- Material: Zirconium



TYROLIT

Model No.	Mfg. No.	Size D" x A"	Grit	Max RPM	Price /Each
NU423	572473	4 1/2 x 7/8	40	13 300	4.34
NU424	454393	4 1/2 x 7/8	60	13 300	4.34
NU425	455312	4 1/2 x 7/8	80	13 300	4.34
NU426	824385	5 x 7/8	40	12 250	5.01
NU427	455303	5 x 7/8	60	12 250	5.01
NU428	458587	5 x 7/8	80	12 250	5.01

ABRASIVES



CERABOND FLAP DISC

- Easy-Trim plastic backing
- Can be used on steel and stainless steel
- Ideal for weld removal, edge work and finishing applications
- Abrasive Material: Ceramic
- Type: 27



Model No.	Mfg. No.	Grit	Size D" x A"	Price /Each
NV268	34315841	40	4-1/2 x 7/8	7.73
NV269	34315842	60	4-1/2 x 7/8	7.73
NV270	34315843	80	4-1/2 x 7/8	7.73
NV271	34315845	40	5 x 7/8	10.40
NV272	34315846	60	5 x 7/8	9.99
NV273	34315847	80	5 x 7/8	9.99

FLAP DISC

- For demanding grinding applications on different stainless steel grades
- Maximum stock removal on the workpiece thanks to ceramic grain
- Top size coating allows for cool grinding and prevents discolouration of the workpiece
- Even surface finish thanks to the self-sharpening characteristic of the abrasive grain over the entire lifetime of the disc
- Abrasive Material: Ceramic
- Type: 27



Model No.	Mfg. No.	Grit	Size D" x A"	Price /Each
TCT367	34464928	40	4-1/2 x 5/8"-11	8.11
TCT368	34464929	60	4-1/2 x 5/8"-11	8.11
TCT369	34464930	80	4-1/2 x 5/8"-11	8.11
TCT370	34464931	40	4-1/2 x 5/8"-11	10.50
TCT371	34464932	60	5 x 5/8"-11	10.50
TCT372	34464933	80	5 x 5/8"-11	10.50

FLAP DISC

- Ideal for weld removal and edge work
- Used on steel, stainless steel, and aluminum
- Trimmable plastic back
- Abrasive Material: Zirconium
- Type: 27



Model No.	Mfg. No.	Grit	Size D" x A"	Max. RPM	Price /Each
NV013	34299592	40	4-1/2 x 7/8	13 300	9.05
NV014	34299593	60	4-1/2 x 7/8	13 300	9.05
NV015	34299594	80	4-1/2 x 7/8	13 300	9.05
NV016	34299595	40	5 x 7/8	12250	11.30
NV017	34299596	60	5 x 7/8	12250	11.30
NV018	34299597	80	5 x 7/8	12250	11.30

TWIN FLAP DISC

- For steel and stainless steel
- Double flap arrangement for maximum lifetime
- Ceramic grain for highest stock removal rate
- Reduced thermal load
- Abrasive Material: Ceramic, Zirconia Alumina
- Type: 27



Model No.	Mfg. No.	Grit	Size D" x A"	Price /Each
TCT355	34474190	40	4-1/2 x 7/8	8.82
TCT356	34474211	60	4-1/2 x 7/8	8.82
TCT357	34474212	40	5 x 7/8	10.90
TCT358	34474213	60	5 x 7/8	10.90

FLAP DISC

- Ideal for blending sharp corners, heavy, and fillet welds
- High-performance flap disc optimized for use on low powered angle grinders
- Trimmable backing extends disc life
- Abrasive Material: Zirconia Alumina
- Type 27



Model No.	Mfg. No.	Arbor Hole Size"	Diameter"	Grit	Max RPM	Price /Each
NV019	15W454	7/8	4-1/2	40	13 300	9.15
NV020	15W456	7/8	4-1/2	60	13 300	9.15
NV021	15W458	7/8	4-1/2	80	13 300	9.15
NV022	15W462	7/8	4-1/2	120	13 300	9.15
NV023	15W504	7/8	5	40	12 200	9.95
NV024	15W506	7/8	5	60	12 200	9.95
NV025	15W508	7/8	5	80	12 200	9.95
NV026	15W512	7/8	5	120	12 200	9.95
NV027	15W604	7/8	6	40	10 200	13.40
NV028	15W606	7/8	6	60	10 200	13.40
NV029	15W608	7/8	6	80	10 200	13.40
NV030	15W612	7/8	6	120	10 200	13.40
NV031	15W704	7/8	7	40	8600	21.30
NV032	15W706	7/8	7	60	8600	21.30
NV033	15W708	7/8	7	80	8600	21.30
NV034	15W712	7/8	7	120	8600	21.30

D x A: Diameter x Arbor Size

LONG LIFE C-TRIM FLAP DISC

- Designed for heavy-duty use on steel and stainless steel
- Trimmable plastic backing
- Fe, s, and Cl free
- Type: 29



Model No.	Mfg. No.	Diameter"	Grit	Max RPM	Price /Each
7/8" ARBOR, TYPE 29, ZIRCONIUM					
NU780	34239191	4-1/2	40	13 300	8.82
NU781	34239192	4-1/2	60	13 300	8.82
NU584	34239193	4-1/2	80	13 300	8.82
NU585	34239194	4-1/2	120	13 300	8.82
NU784	34239195	5	40	12 250	10.90
NU785	34239196	5	60	12 250	10.90
NU582	34239197	5	80	12 250	10.90
NU581	34239198	5	120	12 250	10.90
5/8"-11 ARBOR, TYPE 27, ZIRCONIA ALUMINA					
TCT359	34464900	4-1/2	40	-	8.82
TCT360	34464921	4-1/2	60	-	8.82
TCT361	34464922	4-1/2	80	-	8.82
TCT362	34464923	4-1/2	120	-	8.82
TCT364	34464925	5	60	-	10.90
TCT365	34464926	5	80	-	10.90
TCT366	34464927	5	120	-	10.90

ENDURO-FLEX™ STAINLESS

- With Eco-Trim™ backing made from natural and sustainable plant fibres this backing can easily be trimmed
- Heat absorbent, high-tech material ensures cooler grinding
- Flap discs contain no fibreglass, no mineral fibres and no epoxy resin
- Feature an ultra resistant built-in threaded arbor for quick and easy disc changes
- A new raised hub fits all standard angle grinder back flanges
- **With Spin-On arbor:** FE free abrasive cloth; consistent finish without any discoloration; cool cutting will not load up or glaze; superior performance on all heat sensitive metals
- **With 7/8" arbor:** A small, universal grinding angle ensures optimal abrasive contact with the work piece for quiet, vibration-free grinding, complete control and total operator comfort



Model No.	Mfg. No.	Size D" x A"	Grit	Max RPM	Price /Each
SPIN-ON ARBOR					
BZ665	06-F-454	4 1/2 x 5/8"-11	40	13 300	18.50
BZ666	06-F-456	4 1/2 x 5/8"-11	60	13 300	18.50
BZ667	06-F-458	4 1/2 x 5/8"-11	80	13 300	18.50
BZ668	06-F-462	4 1/2 x 5/8"-11	120	13 300	18.50
BZ669	06-F-504	5 x 5/8"-11	40	12 200	22.50
BZ670	06-F-506	5 x 5/8"-11	60	12 200	24.30
BZ671	06-F-508	5 x 5/8"-11	80	12 200	22.50
BZ672	06-F-512	5 x 5/8"-11	120	12 200	22.50
BZ673	06-F-604	6 x 5/8"-11	40	10 200	26.50
BZ674	06-F-606	6 x 5/8"-11	60	10 200	26.50
BZ675	06-F-608	6 x 5/8"-11	80	10 200	26.50
BZ676	06-F-612	6 x 5/8"-11	120	10 200	29.00

Model No.	Mfg. No.	Size D" x A"	Grit	Max RPM	Price /Each
7/8" ARBOR					
TE241	15-Q-454	4 1/2 x 7/8	40	13 300	20.00
TE242	15-Q-456	4 1/2 x 7/8	60	13 300	20.00
TE243	15-Q-458	4 1/2 x 7/8	80	13 300	20.00
TE244	15-Q-462	4 1/2 x 7/8	120	13 300	20.00
TE245	15-Q-504	5 x 7/8	40	12 200	24.30
TE246	15-Q-506	5 x 7/8	60	12 200	24.30
TE247	15-Q-508	5 x 7/8	80	12 200	24.30
TE248	15-Q-512	5 x 7/8	120	12 200	24.30
TE249	15-Q-704	7 x 7/8	40	8 600	42.70
TE250	15-Q-706	7 x 7/8	60	8 600	42.70
TE251	15-Q-708	7 x 7/8	80	8 600	42.70
TE252	15-Q-712	7 x 7/8	120	8 600	42.70

FLAP WHEELS

Typical Applications

- Metal fabrication
- Blending welds
- Deburring
- Cleaning and finishing

Conformable to most shapes

Designed to deliver a consistent finish with a uniform rate of cut, flap wheels wear away, continually exposing fresh abrasive. Conformable to most shapes, they are available in coarse to fine grit.

MANDREL MOUNTED FLAP WHEELS

- Mandrel mounted high performance
- Designed with the 1/4" mandrel as a integral part of the wheel
- More aggressive and works great in heavy stock removal operations
- A very durable, long lasting mini flap wheel



MERIT

Model No.	D" x T" x S"	Grit	Max RPM	Price /Each
BQ700	1 x 5/8 x 1/4	40	30 000	6.14
BQ696	1 x 5/8 x 1/4	60	30 000	6.14
BQ697	1 x 5/8 x 1/4	80	30 000	6.14
BQ698	1 x 5/8 x 1/4	120	30 000	6.14
BQ571	1 x 5/8 x 1/4	180	30 000	6.14
BQ699	1 x 5/8 x 1/4	240	30 000	6.14
BQ567	1 x 1 x 1/4	40	30 000	6.45
BQ730	1 x 1 x 1/4	60	30 000	6.45
BQ731	1 x 1 x 1/4	80	30 000	6.45
BQ732	1 x 1 x 1/4	120	30 000	6.45
BQ733	1 x 1 x 1/4	180	30 000	6.45
BQ701	1 x 1 x 1/4	240	30 000	6.45
BQ734	1 x 1 x 1/4	320	30 000	6.45
BQ736	1 3/8 x 5/8 x 1/4	60	30 000	6.14
BQ737	1 3/8 x 5/8 x 1/4	80	30 000	6.14
BQ738	1 3/8 x 5/8 x 1/4	120	30 000	6.14
BQ739	1 3/8 x 5/8 x 1/4	180	30 000	6.14
BQ740	1 3/8 x 5/8 x 1/4	240	30 000	6.14
BQ677	1 1/2 x 1 x 1/4	40	25 000	8.19
BQ741	1 1/2 x 1 x 1/4	60	25 000	8.19
BQ707	1 1/2 x 1 x 1/4	80	25 000	8.19
BQ708	1 1/2 x 1 x 1/4	120	25 000	8.19
BQ742	1 1/2 x 1 x 1/4	180	25 000	8.19
BQ613	1 1/2 x 1 x 1/4	240	25 000	8.19

Model No.	D" x T" x S"	Grit	Max RPM	Price /Each
BQ710	2 x 3/4 x 1/4	40	25 000	9.24
BQ711	2 x 3/4 x 1/4	60	25 000	9.24
BQ712	2 x 3/4 x 1/4	80	25 000	9.24
BQ713	2 x 3/4 x 1/4	120	25 000	9.24
BQ714	2 x 3/4 x 1/4	180	25 000	9.24
BQ754	2 x 1 x 1/4	40	25 000	10.50
NP723	2 x 1 x 1/4	50	25 000	11.50
BQ748	2 x 1 x 1/4	60	25 000	10.50
BQ749	2 x 1 x 1/4	80	25 000	10.50
BQ750	2 x 1 x 1/4	120	25 000	10.50
BQ751	2 x 1 x 1/4	180	25 000	10.50
BQ752	2 x 1 x 1/4	240	25 000	10.50
BQ753	2 x 1 x 1/4	320	25 000	10.50
BQ716	2 x 1 1/2 x 1/4	40	25 000	12.00
BQ755	2 x 1 1/2 x 1/4	60	25 000	12.00
BQ756	2 x 1 1/2 x 1/4	80	25 000	12.00
BQ757	2 x 1 1/2 x 1/4	120	25 000	12.00
BQ760	2 1/2 x 1 x 1/4	40	20 000	11.80
BQ761	2 1/2 x 1 x 1/4	60	20 000	11.80
BQ762	2 1/2 x 1 x 1/4	80	20 000	11.80
BQ763	2 1/2 x 1 x 1/4	120	20 000	11.80
BQ764	2 1/2 x 1 x 1/4	180	20 000	11.80
BQ847	2 1/2 x 1 x 1/4	240	20 000	11.80
BQ765	2 1/2 x 1 x 1/4	320	20 000	11.80

Model No.	D" x T" x S"	Grit	Max RPM	Price /Each
BQ766	2 1/2 x 1 1/2 x 1/4	60	20 000	13.50
BQ767	2 1/2 x 1 1/2 x 1/4	80	20 000	13.50
BQ768	2 1/2 x 1 1/2 x 1/4	120	20 000	13.50
BQ770	3 x 3/4 x 1/4	60	20 000	11.80
BQ771	3 x 3/4 x 1/4	80	20 000	11.80
BQ775	3 x 1 x 1/4	40	20 000	12.90
BQ773	3 x 1 x 1/4	60	20 000	12.90
BQ774	3 x 1 x 1/4	80	20 000	12.90
BQ722	3 x 1 x 1/4	120	20 000	12.90
BQ723	3 x 1 x 1/4	180	20 000	12.90
BQ685	3 x 1 x 1/4	240	20 000	12.90
BQ686	3 x 1 x 1/4	320	20 000	12.90
BQ776	3 x 2 x 1/4	40	12 000	22.30
BQ724	3 x 2 x 1/4	60	12 000	22.30
BQ725	3 x 2 x 1/4	80	12 000	22.30
BQ726	3 x 2 x 1/4	120	12 000	22.30
BQ727	3 x 2 x 1/4	180	12 000	22.30

D x T x S: Diameter x Thickness x Shank

ABRASIVES



BENCH MOUNTED FLAP WHEELS

- Mounted on bench grinder applies light scratch pattern to stainless steel

MERIT

Model No.	D" x T" x A"	Size	Grit	Max RPM	Price /Each
BQ268	5 x 1 1/2 x 5/8	40	12000	36.60	
BQ270	5 x 1 1/2 x 5/8	60	12000	37.60	
BQ271	5 x 1 1/2 x 5/8	80	12000	40.10	
BQ272	5 x 1 1/2 x 5/8	120	12000	43.50	
BQ276	5 x 1 1/2 x 5/8	320	12000	47.50	
BQ302	6 x 1/2 x 1	40	6000	54.30	
BQ303	6 x 1/2 x 1	60	6000	57.20	
BQ305	6 x 1/2 x 1	120	6000	58.40	
BQ280	6 x 1/2 x 1	150	6000	63.10	
BQ306	6 x 1/2 x 1	180	6000	63.40	
BQ308	6 x 1 x 1	40	6000	40.70	
BQ310	6 x 1 x 1	60	6000	41.70	
BQ311	6 x 1 x 1	80	6000	44.60	
BQ312	6 x 1 x 1	120	6000	48.30	
BQ313	6 x 1 x 1	150	6000	51.40	
BQ314	6 x 1 x 1	180	6000	52.80	
BQ315	6 x 1 x 1	240	6000	52.80	

Model No.	D" x T" x A"	Size	Grit	Max RPM	Price /Each
BQ317	6 x 1 1/2 x 1	40	6000	45.70	
BQ319	6 x 1 1/2 x 1	60	6000	46.90	
BQ321	6 x 1 1/2 x 1	120	6000	54.30	
BQ324	6 x 1 1/2 x 1	240	6000	64.90	
BQ325	6 x 1 1/2 x 1	320	6000	59.30	
BQ328	6 x 2 x 1	60	6000	69.80	
BQ329	6 x 2 x 1	80	6000	74.10	
BQ330	6 x 2 x 1	120	6000	81.10	
BQ332	6 x 2 x 1	180	6000	88.50	
BQ333	6 x 2 x 1	240	6000	97.50	
BQ334	6 x 2 x 1	320	6000	88.50	
BQ337	6 x 3 x 1	60	6000	102.00	
BQ338	6 x 3 x 1	80	6000	108.00	
BQ339	6 x 3 x 1	120	6000	119.00	
BQ340	6 x 3 x 1	180	6000	136.00	



Model No.	D" x T" x A"	Size	Grit	Max RPM	Price /Each
BQ342	8 x 1 x 1	40	4500	73.80	
BQ344	8 x 1 x 1	60	4500	75.50	
BQ345	8 x 1 x 1	80	4500	81.30	
BQ346	8 x 1 x 1	120	4500	89.00	
BQ347	8 x 1 x 1	180	4500	96.00	
BQ350	8 x 2 x 1	40	4500	112.00	
BQ353	8 x 2 x 1	80	4500	121.00	
BQ355	8 x 2 x 1	180	4500	150.00	
BQ357	8 x 2 x 1	320	4500	154.00	
BQ281	10 x 1 x 13/4	40	4000	113.00	
BQ360	10 x 1 x 13/4	80	4000	127.00	
BQ361	10 x 1 x 13/4	120	4000	141.00	
BQ364	10 x 1 x 13/4	320	4000	157.00	

COOLCUT™ FLAP WHEELS

These flap wheels are made of the highest industrial quality abrasive cloth and have an optimal number of flaps that are securely bonded and balanced around the hub for highest quality finishing. They are ideal for general purpose blending, shaping and deburring and will give a consistent and uniform grained satin finish in no time.



Model No.	Mfg. No.	D" x T" x A"	Size	Grit	Max RPM	Price /Each
BZ950	15-F-056	1 x 3/8 x 1/4	60	30000	10.00	
BZ951	15-F-058	1 x 3/8 x 1/4	80	30000	10.00	
BZ952	15-F-062	1 x 3/8 x 1/4	120	30000	10.00	
BZ953	15-F-156	1 x 1 x 1/4	60	30000	9.05	
BZ954	15-F-158	1 x 1 x 1/4	80	30000	9.05	
BZ955	15-F-162	1 x 1 x 1/4	120	30000	9.05	
YC398	15-F-006	1 1/2 x 3/8 x 1/4	60	25000	10.40	
UG072	15-F-008	1 1/2 x 3/8 x 1/4	80	25000	10.40	
YC402	15-F-012	1 1/2 x 3/8 x 1/4	120	25000	10.40	
UG073	15-F-106	1 1/2 x 1 x 1/4	60	25000	10.70	
UG074	15-F-108	1 1/2 x 1 x 1/4	80	25000	10.70	
UG075	15-F-112	1 1/2 x 1 x 1/4	120	25000	10.70	
UG076	15-F-124	1 1/2 x 1 x 1/4	240	25000	10.70	

Model No.	Mfg. No.	D" x T" x A"	Size	Grit	Max RPM	Price /Each
YB811	15-F-206	2 x 3/8 x 1/4	60	25000	11.80	
UG077	15-F-208	2 x 3/8 x 1/4	80	25000	11.80	
UG078	15-F-212	2 x 3/8 x 1/4	120	25000	11.80	
YC035	15-F-306	2 x 1 x 1/4	60	25000	11.80	
UG079	15-F-308	2 x 1 x 1/4	80	25000	11.80	
UG080	15-F-312	2 x 1 x 1/4	120	25000	11.80	
UG081	15-F-324	2 x 1 x 1/4	240	25000	11.80	
YC036	15-F-506	2 1/2 x 1 1/2 x 1/4	60	20000	18.20	
UG084	15-F-508	2 1/2 x 1 1/2 x 1/4	80	20000	18.20	
UG085	15-F-512	2 1/2 x 1 1/2 x 1/4	120	20000	18.20	
UG086	15-F-524	2 1/2 x 1 1/2 x 1/4	240	20000	18.20	
UG089	15-F-706	3 x 1 x 1/4	60	15000	18.20	
UG090	15-F-708	3 x 1 x 1/4	80	15000	18.20	
UG091	15-F-712	3 x 1 x 1/4	120	15000	18.20	
UG092	15-F-808	3 x 1 1/2 x 1/4	80	15000	23.50	
UG093	15-F-812	3 x 1 1/2 x 1/4	120	15000	23.50	
UG094	15-F-824	3 x 1 1/2 x 1/4	240	15000	23.50	
YC448	15-F-906	3 x 2 x 1/4	60	11000	25.50	
UG095	15-F-908	3 x 2 x 1/4	80	11000	25.50	
YC449	15-F-912	3 x 2 x 1/4	120	11000	25.50	

D x T x A: Diameter x Thickness x Arbor Size

CUBITRON™ II VITRIFIED GRINDING WHEEL 92VC

- Diameter: 17-7/10"
- Thickness: 1"
- Arbor Size: 8"
- Type: T20

Model No. NYS15
Mfg. No. 7100181614
Price/Each \$1290.44



MOUNTED FLAP WHEEL

- Made of high quality abrasive cloth ideal for general purpose sanding, blending, shaping, cleaning, and deburring on curved, irregular and other hard to reach surfaces
- Mounted on 1/4" spindle for use with drills and die grinders
- Diameter: 3" • Grit: A80
- Thickness: 2" • Arbor Hole Size: 1/4"
- Max. Speed: 12 000 RPM

Model No. AUW002
Mfg. No. 560343
Price/Each \$24.00



BRISTLE DISCS

Bristle discs are ideal for safely cleaning and stripping a wide variety of substances off of metal. The discs will easily cut through hardened enamel, paint, thick dried adhesives, and layers of corrosion, without destroying the underlying material or compromising safety with dangerous flying wires.

In addition, bristle discs do not clog up with substances being removed, and give consistent finishes throughout the life of the discs.

All bristle discs are colour coded by grade and are made of nylon embedded with abrasive to create an abrasive action. Each disc is flexible and easily conforms to contours and tight corners and angles.

ROLOC™ BRISTLE DISCS

- Uniform concentration of mineral throughout the flexible abrasive filled bristles
- Fast cut rate and long performance life for removal of rust, coatings, and flashing
- Roloc™ attachment method for quick and easy disc changes
- All discs feature a 5/8" trim length and are embedded with Regalite™ abrasive mineral



Model No.	Size"	Trim Type	Grit	Colour	Max. RPM	Price /Each
BP106	1	Straight	50	Green	30 000	7.37
BP107	1	Straight	80	Yellow	30 000	7.37
BP105	1	Straight	120	White	30 000	7.37
BP109	2	Tapered	50	Green	25 000	11.86
BP110	2	Tapered	80	Yellow	25 000	11.86
BP108	2	Tapered	120	White	25 000	11.86
BP112	3	Tapered	50	Green	18 000	17.45
BP113	3	Tapered	80	Yellow	18 000	17.45
BP111	3	Tapered	120	White	18 000	17.45

ROLOC™ RADIAL BRISTLE DISCS

- Same characteristics as the Roloc™ bristle discs, but in a radial format
- Roloc™ radial bristle discs come in 3" diameters and have a maximum operating RPM of 25 000



Model No.	Grit	Colour	Price /Each
BP103	50	Green	12.79
BP104	80	Yellow	12.79
BP102	120	White	12.79



ROLOC™ DISC HOLDERS

- Rubber Roloc™ back-up pads are offered in different sizes and degrees of hardness for varying grinding applications
- All Roloc™ disc holders are threaded and require model BP013 1/4", threaded shaft

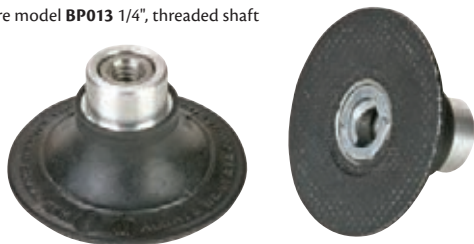

Model No.	Size"	Density	Max. RPM	Price /Each
BP007	1	Medium	30 000	24.30
BP011	2	Soft	20 000	29.25
BP008	2	Medium	25 000	31.92
BP005	2	Hard	25 000	29.25
BP003	2	Extra hard	25 000	35.42
BP012	3	Soft	15 000	35.70
BP009	3	Medium	18 000	35.70
BP006	3	Hard	20 000	35.70
BP004	3	Extra hard	20 000	39.25

ROLOC™ THREADED SHAFT

Model No. BP013 Price/Each \$5.63

RADIAL BRISTLE DISCS

- All discs are very flexible for deburring, cleaning, or finishing intricate or tiny areas
- Ideal for hi-tech housings and components, medical products, cleaning marks off of precision parts and creating satin, and higher, finishes on hard and soft metals



Priced per Package

Model No.	Size"	Shank"	Grit	Colour	Max. RPM	Qty /Pack	Price /Pack
BP096	9/16	1/16	120X	White	30 000	48	78.72
BP097	9/16	1/16	P220X	Red	30 000	48	78.72
BP098	9/16	1/16	P400X	Blue	30 000	48	78.72
BP091	3/4	1/16	80X	Yellow	30 000	48	85.44
BP089	3/4	1/16	P220X	Red	30 000	48	85.44
BP090	3/4	1/16	P400X	Blue	30 000	192	341.76
BP092	3/4	1/16	Pumice	Pink	30 000	48	85.44
BP083	1	1/8	36X	Dark brown	30 000	24	48.72
BP084	1	1/8	50X	Green	30 000	24	48.72
BP085	1	1/8	80X	Yellow	30 000	24	48.72
BP082	1	1/8	120X	White	30 000	24	48.72
BP087	3	3/8	50	Green	25 000	10	127.90
BP088	3	3/8	80	Yellow	25 000	10	127.90

RADIAL BRISTLE BRUSHES FOR BENCH GRINDERS

- Radial bristle brushes have the same characteristics as the other 3M bristle brushes, but come in a convenient 6" size bench grinders
- Each brush comes with its own adapter
- Radial bristle brushes take the place of conventional wire wheels, on bench grinders, for general maintenance and production work
- Nylon bristles eliminate dangerous flying wires



Model No.	Size"	Grit	Colour	Max. RPM	Price /Each
BP093	6	36X	Dark brown	10 000	71.36
BP094	6	50X	Green	10 000	71.36
BP095	6	80X	Yellow	10 000	71.36

RADIAL BRISTLE DISCS FOR RIGHT ANGLE GRINDERS

- 4 1/2" bristle discs with 5/8"-11 threaded hub
- Same safety and efficiency benefits as other bristle discs but in a right angle grinder configuration
- Ideal for cleaning, delaminating, removing rust and oxidation, and deburring a variety of hard and soft metals and plastics
- All discs have a maximum operating speed of 12 000 RPM



Model No.	Size"	Grit	Colour	Price /Each
VV392	4 1/2	36	Brown	45.39
BP079	4 1/2	50	Green	45.39
BP080	4 1/2	80	Yellow	45.39
BP078	4 1/2	120	White	45.39



FIBRE DISCS

Typical Applications

- Material removal
- Weld grinding and blending
- Light deburring and finishing

ZIRCONIA ALUMINA FIBRE DISCS

- Durable zirconia alumina abrasive with a heavy fibre backing
- Superior product for heavy weld and metal grinding
- Cool grinding action that reduces glazing and loading
- Excellent for stainless steel applications



MERIT CERAMIC DISCS

- High performance ceramic alumina abrasive on heavy fibre backing
- Economical choice for heavy stock removal



MERIT

Model No.	Mfg. No.	D"	Size x A"	Grit	Price /Each
BZ560	66623353315	4 1/2	x 7/8	24	2.09
BZ561	66623353316	4 1/2	x 7/8	36	1.98
BZ562	66623353318	4 1/2	x 7/8	50	2.09
BZ563	66623353319	4 1/2	x 7/8	60	1.67
BZ564	66623353320	4 1/2	x 7/8	80	1.54
BZ577	66623357290	5	x 7/8	24	2.51
BZ579	66623357292	5	x 7/8	50	2.09
BZ580	66623357293	5	x 7/8	60	1.98
BZ581	66623357294	5	x 7/8	80	1.99
BZ582	66623357295	7	x 7/8	24	3.69
BZ583	66623357296	7	x 7/8	36	3.39
BZ584	66623357297	7	x 7/8	50	3.14
BZ585	66623357298	7	x 7/8	60	3.56
BZ586	66623357299	7	x 7/8	80	3.35

MERIT

Model No.	Mfg. No.	D"	Size x A"	Grit	Price /Each
BZ573	66623355601	4 1/2	x 7/8	24	2.50
BZ574	66623355602	4 1/2	x 7/8	36	2.42
BZ576	66623355604	4 1/2	x 7/8	60	2.08
NS489	66623365598	4 1/2	x 7/8	80	1.79
BZ569	66623355597	5	x 7/8	24	3.01
BZ570	66623355598	5	x 7/8	36	2.74
BZ571	66623355599	5	x 7/8	50	2.50
BZ572	66623355600	5	x 7/8	60	2.25
NS494	66623366015	5	x 7/8	80	2.07
BZ565	66623355578	7	x 7/8	24	4.74
BZ566	66623355594	7	x 7/8	36	4.57
BZ567	66623355595	7	x 7/8	50	4.41
BZ568	66623355596	7	x 7/8	60	4.28
NS499	66623365600	7	x 7/8	80	3.70

NORTON METAL F240 DISCS

- Quality aluminum oxide grain on heavy fibre backing
- Good for small job around the shop and general purpose applications



NORTON

Model No.	Mfg. No.	D"	Size x A"	Grit	Price /Each
BQ035	66623353309	4 1/2	x 7/8	24	0.94
BQ036	66623353306	4 1/2	x 7/8	36	0.90
BQ037	66623353310	4 1/2	x 7/8	50	0.90
BQ038	66623353311	4 1/2	x 7/8	60	0.85
BQ039	66623353312	4 1/2	x 7/8	80	0.79
BQ040	66623353313	4 1/2	x 7/8	100	0.76
BQ041	66623353314	4 1/2	x 7/8	120	0.76
BQ042	66623357276	5	x 7/8	24	1.08
BQ043	66623357277	5	x 7/8	36	1.05
BQ044	66623357278	5	x 7/8	50	0.99
BQ045	66623357279	5	x 7/8	60	0.97
BQ046	66623357280	5	x 7/8	80	0.93
BQ047	66623357281	5	x 7/8	100	0.93
BQ048	66623357282	5	x 7/8	120	0.90
BQ049	66623357283	7	x 7/8	24	1.81
BQ050	66623357284	7	x 7/8	36	1.76
BQ051	66623357285	7	x 7/8	50	1.61
BQ052	66623357286	7	x 7/8	60	1.53
BQ053	66623357287	7	x 7/8	80	1.48
BQ054	66623357288	7	x 7/8	100	1.41
BQ055	66623357289	7	x 7/8	120	1.37

AIR COOLED RUBBER BACK UP PADS

- Designed for medium to heavy grinding applications
- Slotted aluminum hub design draws cool air behind the disc
- Curved ribs on the rubber face force heat away from the disc and back-up pad
- Cooler cutting action reduces disc loading and increases grinding life
- All pads have 5/8"-11 threaded female hub for mounting



Model No.	Mfg. No.	Description	Max RPM	Price /Each
BZ056	08834195006	4 1/2" back up pad	11 000	30.80
BZ053	08834195002	5" back up pad	10 000	36.90
BZ054	08834195003	7" back up pad	8 500	50.70
BZ052	08834195000	Disc pad nut 5/8"-11	-	9.17
BV731	08834192776	Spanner wrench fits 5/8" and 3/8"	-	12.90

Control spills with confidence



ZENITH
Safety Products

D x A: Diameter x Arbor Size

COOLCUT™ XX

- Featuring cyclone technology, exclusive high tech blend of abrasive grains, bond and cooling agents
- Impressive removal rate
- Work equally well in steel, stainless steel and aluminum



Model No.	Mfg. No.	Size"	Grit	Price /Each
VV437	15-X-453	4 1/2	36	3.10
VV438	15-X-455	4 1/2	50	2.85
VV439	15-X-456	4 1/2	60	2.85
VV440	15-X-458	4 1/2	80	2.65
VV441	15-X-460	4 1/2	100	2.65
VV442	15-X-462	4 1/2	120	2.65
VV443	15-X-503	5	36	3.40
VV444	15-X-505	5	50	3.20
VV445	15-X-506	5	60	3.20
VV446	15-X-508	5	80	3.00
VV447	15-X-510	5	100	3.00
VV448	15-X-512	5	120	3.00
VV449	15-X-703	7	36	5.75
VV450	15-X-705	7	50	4.75
VV451	15-X-706	7	60	4.75
VV452	15-X-708	7	80	4.60
VV453	15-X-710	7	100	4.60
VV454	15-X-712	7	120	4.60

COOLCUT™

- For general purpose sanding, light weld removal, surface cleaning and finishing
- High removal rate, cool cutting



COOLCUT

Model No.	Mfg. No.	D"	Size x	A"	Grit	Price /Each
UG017	15-C-452	4 1/2	x	7/8	24	1.55
BZ797	15-C-453	4 1/2	x	7/8	36	1.45
YB809	15-C-454	4 1/2	x	7/8	40	1.45
BZ798	15-C-455	4 1/2	x	7/8	50	1.35
UG018	15-C-456	4 1/2	x	7/8	60	1.35
UG019	15-C-458	4 1/2	x	7/8	80	1.20
UG020	15-C-460	4 1/2	x	7/8	100	1.20
UG022	15-C-502	5	x	7/8	24	1.65
BZ799	15-C-503	5	x	7/8	36	1.55
UG023	15-C-504	5	x	7/8	40	1.55
BZ800	15-C-505	5	x	7/8	50	1.45
UG024	15-C-506	5	x	7/8	60	1.45
UG025	15-C-508	5	x	7/8	80	1.35
UG026	15-C-510	5	x	7/8	100	1.35
UG027	15-C-512	5	x	7/8	120	1.35
UG034	15-C-702	7	x	7/8	24	3.10
UG035	15-C-703	7	x	7/8	36	2.95
UG036	15-C-705	7	x	7/8	50	2.85
UG037	15-C-706	7	x	7/8	60	2.69
UG038	15-C-708	7	x	7/8	80	2.60
UG039	15-C-710	7	x	7/8	100	2.60
UG040	15-C-712	7	x	7/8	120	2.60

D x A: Diameter x Arbor Size

TOPCUT™

- For the toughest weld removal, grinding and blending applications
- Blue zirconium abrasive grain to remove more material faster
- High strength heat resistant bond for longest disc life



Model No.	Mfg. No.	D"	Size x	A"	Grit	Price /Each
UG134	15-P-452	4 1/2	x	7/8	24	2.40
UG135	15-P-453	4 1/2	x	7/8	36	2.30
UG137	15-P-502	5	x	7/8	24	2.50
UG140	15-P-702	7	x	7/8	24	3.95
UG141	15-P-703	7	x	7/8	36	3.80

ACCESSORIES



BACKING PAD ASSEMBLIES (5/8"-11 THREAD)

High quality impact resistant plastic with excellent heat dissipation characteristics; individually packaged, one clamping nut included



Model No.	For sanding disc diameters"	Price /Each
VE827	4 1/2	16.60
UG060	5	18.20
UG062	6	26.60
UG055	7	27.70

TURBO ACTION BACKING PADS (5/8"-11 THREAD)

Special saucer shaped backing pad with ribbed backing, assures a continuous stream of air between pad and disc for cool operation and long disc life; complete with 5/8"-11 clamping nut



Model No.	Description	Dia."	Price/Each
TAV092	Standard Pad, Black	4 1/2	27.70
TAV086	Turbo Action Backing Pads	5	31.70
TAV071	Turbo Action Backing Pads	6	43.00
UG131	Turbo Action Backing Pads	7	47.30
UG132	Soft pad, White	7	47.30

ABRASIVES

3M™ 787C FIBRE DISC

- Ideal for use on stainless steel and non-ferrous metals
- Requires less pressure than a conventional ceramic disc
- Abrasive Material: Ceramic



Model No.	Size			Grit	Price /Each
	D"	x	A"		
NV037	4 1/2	x	7/8	36	2.52
NV039	4 1/2	x	7/8	60	2.23
NV042	4 1/2	x	7/8	80	2.10
NV045	4 1/2	x	7/8	120	2.10
NV038	5	x	7/8	36	2.87
NV040	5	x	7/8	60	2.56
NV043	5	x	7/8	80	2.39
NV046	5	x	7/8	120	2.39
NV716	7	x	7/8	36	3.73
NV041	7	x	7/8	60	3.61
NV044	7	x	7/8	80	3.40
NV047	7	x	7/8	120	3.40

381C ALUMINUM OXIDE FIBRE DISCS

- General purpose disc for weld removal, grinding and blending
- Aluminum oxide
- Resin bonded for heat resistance



Model No.	Size			Grit	Price /Each
	D"	x	A"		
BP244	4 1/2	x	7/8	80	3.75
BP246	5	x	7/8	80	3.82
BP247	7	x	7/8	80	5.38

ACCESSORIES

- **Disc Pad Hubs:** Plastic hubs with 5/8"-11 metal insert; use with 3M disc pad face plates
- **Disc Retainer Nuts:** For use with all 3M disc pad face plates, disc pads and 3M disc pad hubs; nuts have 5/8"-11 threaded arbor hole in three depths to accommodate grinder shaft lengths
- **Disc Pad Face Plates:** Backup plates for fibre discs 3M disc pad face plates are colour coded by density; ribbed plates result in cooler running discs; use harder face plates for heavier stock removal applications



BP212



NS715



BP219



Model No.	Size"	Price/Each
DISC PAD HUBS		
BP212	2 1/2	79.70
BP213	4 1/2	80.49
DISC RETAINER NUTS		
BP219	5/8	9.01
BP217	1/2	9.01
BP218	3/8	9.01

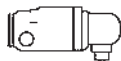

- Disc Pad Hub
- Disc Pad Face Plate
- Fibre Disc
- Disc Retainer Nut

DISC PAD FACE PLATES

Model No.	Size"	Max. RPM	Hardness - Colour	Price /Each
NS715	4 1/2	13 300	Medium - Grey	36.73
BP188	5	12 000	Medium - Grey	49.25
BP187	5	12 000	Hard - Black	49.25
BP190	5	12 000	Extra Hard - Red	49.25
BP192	7	8 600	Medium - Grey	71.18
BP191	7	8 600	Hard - Black	71.18
BP194	7	8 600	Extra Hard - Red	71.18

POWERFLEX SEMI-FLEXIBLE DISC

- Specially designed for grinding and finishing concrete, stone, hard building materials and fiberglass
- Made from extremely sharp silicon carbide grains for fast cutting and long wheel life
- Manufactured by attaching multiple layers of silicone carbide to a semi-flexible fibre backing
- Spiral grooves in the abrasive coating provides quick clearing of ground-off stock
- Multiple cooling holes reduce the build-up of heat during grinding operations, greatly extending the life of the disc
- The type 29 convex profile helps prevent gouging of the work piece and reduces operator fatigue by making it easier to maintain correct grinding angle
- Mount to angle grinders using standard resin fibre disc back-up pads and nuts
- Max. RPM: 12 200
- Type: 29



Model No.	Mfg. No.	Size			Grit	Price /Each
		D"	x	A"		
UAV959	500221	5	x	7/8	C16	9.44

CANADA'S LEADING MATERIAL HANDLING SUPPLIER

D x A: Diameter x Arbor Size

CUBITRON™ II FIBRE DISC

- To be used with right angle grinders
- 3M Precision Shaped Ceramic Grain yields higher cut rates and cooler cut while completing more parts per disc than conventional fibre discs
- Disc life is significantly longer, completing more parts per disc and requiring fewer disc changes
- These discs lasts up to two times longer than other ceramic abrasives – wears evenly, runs cool and optimizes mineral breakdown
- Stiff fiber backing and a strong resin bond provide durability and tear-resistance for heavyweight applications such as high-pressure weld grinding and beveling
- Attachment Type: TN



3M

Model No.	Mfg. No.	Diameter"	Grit	Max. RPM	Price /Each
NY514	7010326768	4 1/2	80	13 300	5.73
NY511	AB27644	7	80	8600	5.40

FIBRE DISC 782C

- Rapidly cuts carbon steel
- 3M Precision Shaped Ceramic Grain yields higher cut rates while completing more parts per disc than conventional discs
- Long-lasting abrasive helps reduce cost
- Stiff fiber backing and strong resin bond provide durability and tear-resistance
- Advanced abrasive technology makes it an excellent choice for tough applications including weld removal, blending and finish refinement
- Abrasive Material: Ceramic
- For Use With: Right Angle Grinders
- Attachment Type: TN
- Coat Type: Closed Coat
- Bond Type: Resin
- Hole Configuration: TN450E
- Colour: Maroon



3M

Model No.	Mfg. No.	Diameter"	Grit	Max. RPM	Price /Each
NY516	AB89613	4-1/2	80+	13 300	4.10

QUICK-CHANGE FIBRE DISC

- To be used with right angle grinders
- Rapidly cuts hard-to-grind metals like stainless steel and high nickel alloys
- 3M Precision Shaped Ceramic Grain yields higher cut rates and cooler cut while completing more parts per disc than conventional fibre discs
- Grinding aid minimizes grinding temperatures for heat-sensitive alloys
- Stiff fiber backing and strong resin bond provide durability and tear-resistance
- Diameter: 7"
- Abrasive Material: Ceramic Grain
- Attachment Type: TN



3M

Model No.	Mfg. No.	Diameter"	Grit	Max. RPM	Price /Each
NY510	AB89660	7	120	8600	5.34

SCOTCH-BRITE™ LIGHT GRINDING & BLENDING DISC

- Non-woven disc grinds and blends in a single step
- 3M ceramic aluminum oxide cuts fast and remain consistent over the life of the disc
- Scotch-Brite™ material won't melt on hot welds, allowing blending without waiting
- Attachment Type: TN



3M

Priced per Case

Model No.	Mfg. No.	Diameter"	Grit	Max. RPM	Qty /Case	Price /Each
NY495	SB60348	4-1/2"	Heavy-Duty Coarse	13 300	50	469.00
NY499	SB60350	5"	Heavy-Duty Coarse	12 000	50	350.00
NY496	SB60336	5-7/8"	Heavy-Duty Coarse	10 000	50	346.50
NY498	SB60345	7"	Heavy-Duty Coarse	6 000	25	299.75
NY500	SM19722	7"	Heavy-Duty Coarse	8 600	25	309.25
NY497	SB60347	7-7/8"	Heavy-Duty Coarse	6 000	25	299.75
NY501	SB60349	4-1/2"	Super-Duty Coarse	13 300	50	469.00
NY503	SB60343	5"	Super-Duty Coarse	10 000	50	346.50
NY505	SB60351	5"	Super-Duty Coarse	12 000	50	350.00
NY502	SB60341	5-7/8"	Super-Duty Coarse	10 000	50	346.50
NY504	SM15210	7"	Super-Duty Coarse	6 000	25	342.50
NY506	SM15208	7"	Super-Duty Coarse	8 600	25	308.75

CLOTH BACK SANDING DISC

- These cloth discs are ideal for grinding, blending, rust and scale removal, and deburring on all types of metal
- The tough, cloth backing on these discs resists tearing and along with quality resin bonding agents and aluminum oxide grains, provides a product that performs well
- Compatible with all roll-on (type "R") mounting systems
- The quick change roll-on system makes changing discs easy and fast, saving time and increasing productivity
- Mount: R
- Abrasive Material: Aluminum Oxide



JET

Model No.	Mfg. No.	Diameter"	Grit	Max. RPM	Price /Each
NY517	502152	3	240	20 000	1.62

BUFF & BLEND HP DISC

- Tough HP material is stiffer and more tear-resistant than GP material and is well-suited for edge deburring and metal removal
- Open web is load resistant, limiting buildup of debris that can clog the abrasive center hole discs come in a range of medium to large sizes to meet many different project specifications
- Aluminum Oxide cuts sharp, helps produce a consistent scratch pattern, and works well on ferrous and non-ferrous metals
- Red discs contain aluminum oxide, very fine (VFN) grade abrasive
- Pliable open web removes burrs and surface contaminants without gouging the substrate
- Diameter: 6"
- Grit: VFN
- Abrasive Material: Aluminum Oxide
- Qty/Pkg.: 10

Model No. AUW245
Mfg. No. 7000121897
Price/Package \$6.40

3M





SPEED-LOK TS & TR DISCS

Typical Applications

- Light to medium pressure grinding
- Blending, levelling and finishing applications
- For use on contours or flat surfaces

Features & benefits

Speed-Lok fastener, allows quick, tool-free disc changes allow for more grinding time
Twist on and twist off in 2 1/2 turns, disc locks securely to back-up pad, but is easily removed

NORTON SG BLAZE R980P CLOTH DISCS

- SG ceramic grain, provides coolest cut and significantly faster cut rates
- Improved resin bond system and durable backing offers greater durability and longest life on tough applications and stainless steel, and edge-fray resistance
- Polyester Y-wt backing, 3-ply laminate discs (yellow backing) more aggressive; ideal when durability and long life are required



Size"	Grit	TS (Type II) Discs			TR (Type III) Discs		
		Model No.	Mfg. No.	Price /Each	Model No.	Mfg. No.	Price /Each
1 1/2	36	NS547	66261162307	1.30	NS559	66261162308	1.30
1 1/2	50	NS548	66261162309	1.14	NS560	66261162310	1.14
1 1/2	60	NS549	66261162311	1.21	NS561	66261162312	1.21
1 1/2	80	NS550	66261162313	1.21	NS562	66261162314	1.21
2	36	NS551	66261162317	1.90	NS563	66261162318	1.90
2	50	NS552	66261162319	1.81	NS564	66261162320	1.81
2	60	NS553	66261162321	1.65	NS565	66261162322	1.65
2	80	NS554	66261162323	1.65	NS566	66261162324	1.65
3	36	NS555	66261162327	2.39	NS567	66261162328	2.39
3	50	NS556	66261162329	2.31	NS568	66261162330	2.31
3	60	NS557	66261162331	2.19	NS569	66261162332	2.19
3	80	NS558	66261162333	2.19	NS570	66261162334	2.19

MERIT ZIRC PLUS R801 CLOTH DISCS

- Self-sharpening, zirconia alumina abrasive, cooler cut, longer life
- Heavy Y-wt backing, two-ply construction, extended durability and reduced edge-wear
- For grinding and deburring stainless steel



Size"	Grit	TS (Type II) Discs			TR (Type III) Discs		
		Model No.	Mfg. No.	Price /Each	Model No.	Mfg. No.	Price /Each
1 1/2	60	BR818	08834167061	1.01	BR842	08834167103	1.01
1 1/2	80	BR819	08834167062	1.01	BR843	08834167104	1.01
2	36	BQ023	08834167065	1.65	BR845	08834167107	1.65
2	50	BQ025	08834165583	1.56	BR847	08834167109	1.56
2	60	BQ026	08834167068	1.48	BR848	08834167110	1.48
2	80	BQ027	08834167069	1.48	BR849	08834167111	1.48
3	36	BQ029	08834167072	2.31	BR851	08834167114	2.31
3	50	BQ031	08834167074	2.19	BR853	08834167116	2.19
3	60	BQ032	08834167075	2.08	BR854	08834167117	2.08
3	80	BQ033	08834167076	2.02	BR855	08834167118	2.02

MERIT ALO RESIN BOND CLOTH DISCS

- Premium aluminum oxide abrasive
- Long life
- Heavy-weight cloth construction
- Excellent durability
- X-wt cotton backing
- Ideal for aggressive stock removal applications
- Resistant to heat



Size"	Grit	TS (Type II) Discs			TR (Type III) Discs		
		Model No.	Mfg. No.	Price /Each	Model No.	Mfg. No.	Price /Each
1-1/2	36	N0045	69957399626	0.65	-	-	-
1-1/2	40	N0046	69957399627	0.65	N0066	69957399695	0.65
1-1/2	50	N0047	69957399628	0.65	-	-	-
1-1/2	60	N0048	69957399629	0.65	-	-	-
1-1/2	80	N0049	69957399630	0.65	N0067	69957399698	0.65
1-1/2	100	N0050	69957399631	0.65	-	-	-
1-1/2	120	N0051	69957399632	0.65	N0068	69957399700	0.65
2	36	N0052	69957399638	0.93	N0069	69957399706	0.93
2	40	N0053	69957399639	0.93	N0070	69957399707	0.93
2	50	N0054	69957399640	0.93	N0071	69957399708	0.93
2	60	N0055	69957399641	0.93	N0072	69957399709	0.93
2	80	N0056	69957399642	0.93	N0073	69957399710	0.93
2	100	N0057	69957399643	0.93	N0074	69957399711	0.93
2	120	N0058	69957399644	0.93	N0075	69957399712	0.93
3	36	N0059	69957399650	1.36	N0076	69957399718	1.36
3	40	N0060	69957399651	1.36	N0077	69957399719	1.36
3	50	N0061	69957399652	1.36	N0078	69957399720	1.36
3	60	N0062	69957399653	1.36	N0079	69957399721	1.36
3	80	N0063	69957399654	1.36	N0080	69957399722	1.36
3	100	N0064	69957399655	1.36	N0081	69957399723	1.36
3	120	N0065	69957399656	1.36	N0082	69957399724	1.36

BACK UP PADS



Description	Max RPM	TS (Type II)			TR (Type III)		
		Model No.	Mfg. No.	Price /Each	Model No.	Mfg. No.	Price /Each
1 1/2" Medium	30000	BR283	08834164146	18.40	-	-	-
1 1/2" Hard	30000	BR434	08834164622	18.40	-	-	-
2" Medium	30000	BR284	08834164198	20.40	BR469	08834164922	20.20
2" Hard	30000	BR435	08834164624	20.20	BR439	08834164643	20.20
3" Medium	20000	BR281	08834164113	22.70	BR475	08834164949	22.70
3" Hard	20000	BR164	08834161626	22.40	BR272	08834164036	22.40

MOVING YOU FORWARD



361F DISCS

- General purpose grinding, blending and deburring on all metals
- Heavy-duty cloth backing



ROLOC™

Model No.	Size"	Grit	Price /Each
BP336	2	24	1.56
BP338	2	36	1.46
BP340	2	50	1.37
BP342	2	60	1.30
BP344	2	80	1.27
BP346	2	P100	1.27
BP348	2	P120	1.27
BP350	2	P150	1.27
BP352	2	P180	1.27
BP353	2	P240	1.27
BP337	3	24	2.00
BP339	3	36	1.85
BP341	3	50	1.74
BP343	3	60	1.69
BP345	3	80	1.65
BP347	3	P100	1.65
BP349	3	P120	1.65
BP351	3	P150	1.65
BP354	3	P240	1.65



ROLOC™ TSM

Model No.	Size"	Grit	Price /Each
BP326	2	36	1.87
BP328	2	60	1.68
BP332	2	P100	1.63
BP335	3	P120	2.11

ROLOC™ DISC PADS

Rubber back-up pads are available in different diameters and degrees of hardness for varying grinding applications. Pads are internally threaded to receive any standard 1/4"-20 thread shaft.



Model No.	Size"	Hardness	Max. RPM	Price /Each
BP008	2	Medium	25 000	31.92
BP005	2	Hard	25 000	29.25
BP009	3	Medium	18 000	35.70
BP006	3	Hard	20 000	35.70

ROLOC™ TSM DISC PADS

For use with Roloc™ TSM grinding discs and screw on abrasive discs.



Model No.	Size"	Hardness	Max. RPM	Price /Each
BP517	2	Medium	25 000	41.27
BP516	2	Hard	25 000	43.16
BP518	3	Hard	20 000	50.87

1/4" THREADED SHAFTS

Needed with all Roloc™ disc pads.

Model No.	Size"	Hardness	Price /Each
BP013	1/4 x 1/4	Thread	5.63

ALUMINUM OXIDE 2 PLY DISCS

- Best disc for general purpose grinding, deburring and blending on ferrous metals

Features

- Variety of Quick Change fastening systems
- Multiple layers of backing

Benefits

- Instant disc changes
- Disc is centered
- Smooth running
- Works well on flat or contour surfaces
- Aggressive stock removal
- Greater productivity

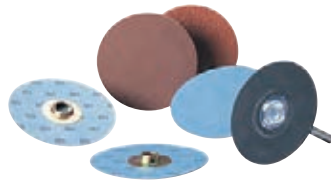

SOCATT® DISCS

Model No.	Size"	Grit	Price /Each
VU392	2	24	1.70
VU394	2	40	1.52
VU396	2	60	1.42

Model No.	Size"	Grit	Price /Each
VU398	2	100	1.38
VU401	2	180	1.25
VU405	3	36	2.00

HOLDER PADS

- With mandrel



Model No.	Dia."	Density	Price /Each
FOR SMALL DIAMETER SOCATT® DISCS			
VU601	2	Soft	28.18
VU602	2	Medium	27.04
VU603	2	Firm	32.21
VU605	3	Medium	31.26
VU606	3	Firm	37.23
FOR SMALL DIAMETER LOCKIT® DISCS			
VU611	2	Medium	27.04
VU612	2	Firm	32.21
VU613	3	Soft	34.31
VU614	3	Medium	31.26

MATRIX
INDUSTRIAL PRODUCTS

Maintain the ideal temperature in your workplace



PSA & HOOK & LOOP PAPER DISCS

Typical Applications

- Preparing primed and painted surfaces for finishing
- Stripping primer and paint
- Sanding of plastic and fibreglass
- Light weld blending and deburring
- Bare wood sanding
- Finishing metal of all types

NO-FIL ADALOX A275 DISCS

- Premium P-graded, heat-treated aluminum oxide abrasive, superior life fast cut rate, consistent finish
- Unique fibre-reinforced, B-wt latex-saturated backing, 50-60% improvement in tears strength and can be used wet
- Water-based stearate, non-pigmented, No-Fil coating, provides maximum load resistance and extended life; no colour transfer to work
- The PSA adhesive is protected from air-borne contaminants
- Hook and loop are reusable discs that reduce waste



RESIN FIBRE SANDING DISC

- Zirconia Alumina is a well established, high performance grain and is popular where productivity and life are the important factors
- This very sharp, tough grain offers long life and aggressive cool cutting action
- Excellent for heavy weld and metal grinding of steel and stainless steel materials
- Ideal for medium to heavy pressure grinding
- Use with resin fibre disc back-up pads
- Arbor Size: 7/8"



Model No.	Mfg. No.	Size"	Grit	Price /Each
-----------	----------	-------	------	-------------

HOOK & LOOP PAPER DISCS				
NZ005	66261131549	5	P80	0.96
NZ006	66261131548	5	P100	0.87
NZ007	66261131547	5	P120	0.87
NZ008	66261131546	5	P150	0.87
NZ009	66261131545	5	P180	0.87
NZ010	66261131544	5	P220	0.87
NZ011	66261131543	5	P240	0.87
NZ012	66261131542	5	P280	0.87
NZ013	66261131541	5	P320	0.87
NZ014	66261131539	5	P400	0.87
NZ015	66261131538	5	P500	0.87
NZ016	66261131537	5	P600	1.00
NZ017	66261131536	5	P800	1.00
NZ021	6626113566	6	P80	1.41
NZ022	6626113565	6	P100	1.24
NZ023	6626113564	6	P120	1.24
NZ024	6626113563	6	P150	1.24
NZ025	6626113562	6	P180	1.24
NZ026	6626113561	6	P220	1.24
NZ027	6626113560	6	P240	1.24
NZ028	6626113559	6	P280	1.24
NZ029	6626113558	6	P320	1.24
NZ030	6626113556	6	P400	1.24
NZ031	6626113555	6	P500	1.24
NZ032	6626113554	6	P600	1.24
NZ033	6626113553	6	P800	1.24

STICK & SAND PAPER DISCS				
NS025	66261131464	5	P80	75.30
NS675	66261131463	5	P100	69.50
NS030	66261131462	5	P120	69.50
NS029	66261131461	5	P150	69.50
NS028	66261131460	5	P180	69.50
NS027	66261131459	5	P220	69.50
NS026	66261131458	5	P240	69.50
NS676	66261131457	5	P280	69.50
NS677	66261131456	5	P320	69.50
NS678	66261131454	5	P400	69.50
NS679	66261131453	5	P500	69.50
NS680	66261131452	5	P600	69.50
NS681	66261131451	5	P800	69.50
NS018	66261131481	6	P80	107.00
NS019	66261131480	6	P100	98.30
NS020	66261131479	6	P120	98.30
NS682	66261131478	6	P150	98.30
NS021	66261131477	6	P180	98.30
NS022	66261131476	6	P220	98.30
NS023	66261131475	6	P240	98.30
NS683	66261131474	6	P280	98.30
NS024	66261131473	6	P320	98.30
NZ001	66261131471	6	P400	98.30
NZ002	66261131470	6	P500	98.30
NZ003	66261131469	6	P600	98.30
NZ004	66261131468	6	P800	98.30

Model No.	Mfg. No.	Size"	Grit	Price /Each
-----------	----------	-------	------	-------------

UAV978	502527	7	Z24	3.90
--------	--------	---	-----	------

GOLD RESERVE A296 PAPER H&L VACUUM DISC

- P-graded premium aluminum oxide abrasive produces a quick, cool cut and a more consistent surface finish
- Water-based, non-loading (No-Fil) stearate coating and vacuum holes minimize clogging and maximize dust extraction and disc life
- Strong C-weight high latex/paper backing resists tearing while staying conformable and flexible
- Good choice for medium grit sanding and finishing on primed or painted surfaces, wood, composites, fibreglass, aluminum and metals; the hook-and-loop backing means quick and easy disc changes and vacuum holes maximize dust extraction and life
- Backing Weight: C-Weight
- Qty/Pkg.: 50

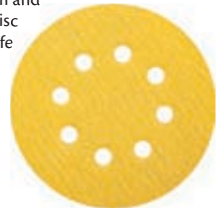

Model No.	Mfg. No.	Size"	Grit	Price /Each
-----------	----------	-------	------	-------------

NY449	66261183918	5	120	29.60
NY450	63642506225	6	240	31.30
NY451	66623307114	5	320	25.50

RIBBED DISC PAD FACE PLATE

- One-piece design for added convenience
- Extra-hard face plate designed to get the most out of your coarse grade fibre discs
- Ribbed face plate designed to increase unit pressure
- Low-profile design will fit most tools and guards
- Spacers allow for easy height adjustment
- Simple one-piece design means a lower price, fewer lost parts, and easier ordering than two-piece face plate and disc hub
- Compatible with TN quick-change attachment systems
- Threaded design allows for easy, secure attachment to tool
- For Disc Type: Cubitron™ II Fibre Discs



Model No.	Mfg. No.	Diameter	Max. RPM	Price /Each
-----------	----------	----------	----------	-------------

NY512	AB88655	4-1/2"	13 300	32.39
NY513	AB88657	7"	8600	47.10

CUBITRON™ II STIKIT™ 732U PAPER DISC ROLL

- For best results, use with 3M® Elite Orbital Sanders
- 3M® precision-shaped ceramic grain technology provides fast cut and long life
- Ideal for a wide variety of substrates and applications focused primarily on stock removal
- 3M® Stikit™ attachment makes changing discs fast and easy
- Convenient disc rolls eliminate the need to remove disc liners from individual discs
- Diameter: 6"
- Abrasive Material: Ceramic
- Backing Weight: C-Weight
- Max. RPM: 10000
- Colour: Purple
- Qty/Roll: 50



Model No.	Mfg. No.	Grit	Price /Each
NV721	AB86836	80	218.35
NV742	AB86837	120	179.49
NV736	AB87067	180	179.49
NV760	AB87101	220	179.49

BACK UP PADS FOR PSA & HOOK AND LOOP PAPER DISCS

- Available with PSA or hook and loop faces, both are shock resistant and have a fibreglass backing plate with a riveted 5/16"-24 threaded shank for added strength and increased heat resistance
- Low profile pads, soft density utilizes 1/2" thick foam for fine finish sanding and offer moderate conformability and medium density has 1/2" thick urethane foam for intermediate and finish sanding



Model No.	Mfg No.	Description	Max RPM	Price /Each
NR940	63642506126	5" PSA Soft Low Profile	15 000	45.60
NR941	63642506131	5" PSA Medium Low Profile	15 000	27.80
NR943	63642506129	5" NorGrip Soft Low Profile	15 000	48.90
NZ049	63642506135	5" NorGrip Medium Low Profile	15 000	30.40
NR945	63642506127	6" PSA Soft Low Profile	15 000	48.60
NR946	63642506133	6" PSA Medium Low Profile	15 000	48.60
NR948	63642506130	6" NorGrip Soft Low Profile	15 000	60.50
NR947	63642506137	6" NorGrip Medium Low Profile	15 000	60.50

236U STIKIT™ DISC ROLLS

- Aluminum oxide C-wt paper
- Strong paper backing provides durability and increase cut rate
- Open coat minimizes loading
- Discs for paint, primer, wood, metal, plastic and fibreglass
- 100 discs per roll, no holes



Model No.	Mfg. No.	Size"	Grade	Price /Each
NX291	AB86488	5	P80	60.27
NX282	AB86489	5	P100	60.27
NX283	AB88700	5	P120	60.27
NX284	AB86490	5	P150	60.27
NX285	AB86492	5	P180	60.27
NX286	AB86493	5	P220	60.27
NX287	AB86494	5	P240	60.27
NX289	AB86496	5	P400	60.27
NX290	AB86497	5	P500	60.27
NX301	AB86468	6	P80	79.90
NX292	AB86469	6	P100	79.90
NX293	AB86470	6	P120	79.90
NX294	AB86471	6	P150	79.90
NX295	AB86472	6	P180	79.90
NX296	AB86473	6	P220	79.90
NX297	AB86474	6	P240	79.90
NX298	AB86475	6	P320	79.90
NX299	AB86476	6	P400	79.90
NX300	AB86477	6	P500	79.90

STIKIT™ DISC PADS

- Provides excellent disc adhesion yet allows quick, easy removal
- Has medium density foam and a 45° tapered edge for flexibility
- Lightweight and shock-resistant with blue vinyl face
- Use with dual action and random orbital sanders; maximum RPM of 10000



Model No.	Dimensions	For use with	Price /Each
BP215	5" x 3/4" x 5/16"-24 Ext	5" Stikit™ Discs	33.26
BP216	6" x 3/4" x 5/16"-24 Ext	6" Stikit™ Discs	87.99

LARGE DIAMETER CLOTH PSA DISCS

Typical Applications

- Used on stationary disc machines
- For dimensioning
- For finishing metal workpieces
- Pressure sensitive adhesive offers fast, convenient mounting
- Made without centre holes for full-face usage

NORZON PLUS R821P DISCS

- Self-sharpening, zirconia alumina abrasive, offers cooler cut and extended life
- Heavy Y-wt backing, is durable, reduced edge wear
- Ideal for grinding and deburring stainless steel



Model No.	Mfg. No.	Size"	Grit	Price /Each
NZ057	66261138318	12	24	21.50
NZ058	66261138319	12	36	20.40
NZ059	66261138320	12	40	19.00
NZ060	66261138321	12	50	17.80
NZ061	66261138322	12	60	16.70
NZ062	66261138323	12	80	15.50

METALITE R228 DISCS

- Premium aluminum oxide abrasive
- Long life
- Heavy, X-wt cotton backing
- Durable
- Ideal for aggressive stock removal applications
- Resistant to heat



Model No.	Mfg. No.	Size"	Grit	Price /Each
NZ077	66261136635	12	36	12.30
NZ078	66261136630	12	40	11.60
NZ079	66261136625	12	50	11.00
NZ080	66261136620	12	60	10.30
NZ081	66261136615	12	80	9.67
NZ082	66261136614	12	100	9.17
NZ083	66261136613	12	120	9.17

ABRASIVES



CUBITRON™ II HOOKIT™ CLEAN SANDING FILM DISC 775L

- To be used with random orbital sanders
- Revolutionary 3M Precision Shaped Ceramic Grain technology provides fast cut and long life
- Cuts up to 2x as fast and lasts up to 6x as long as conventional abrasives
- Film backing for greater tear-resistance and edge retention
- Ideal for a broad range of applications focused primarily on stock removal and are effective on a wide variety of substrates, including metals, composites, gelcoat and whitewood
- 3M™ Hookit™ Attachment makes changing discs fast and easy
- The triangular shaped ceramic mineral is designed to slice through the substrate, rather than gouging or 'plowing' like conventional abrasives
- Backing Weight: 3 mils
- Attachment Type: Hook & Loop
- Bond Type: Resin
- Coat Type: Open Coat

NV465



NV734

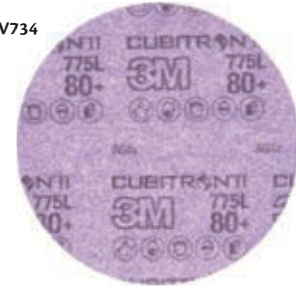

Model No.	Mfg. No.	Size"	Grit	Hole Configuration	Price /Each
NV465	AB86822	5	80	500LG	1.64
NV466	AB86823	5	120	500LG	1.36
NV457*	AB64258	5	150	500LG	68.00
NV458*	AB64264	5	180	500LG	68.00
NV467	AB64270	5	220	500LG	1.36
NV459*	AB47097	5	240	500LG	68.00
NV468	AB47081	5	320	500LG	1.36
NV460*	AB05058	5	400	500LG	68.00
NV734	AB86818	5	80	500X	1.36
NV754	AB86819	5	120	500X	1.14
NV461*	AB87026	5	150	500X	57.00
NV748	AB64263	5	180	500X	1.14
NV462*	AB64269	5	220	500X	57.00
NV463*	AB47095	5	240	500X	57.00
NV759	AB47080	5	320	500X	1.14
NV464*	AB05055	5	400	500X	57.00

Model No.	Mfg. No.	Size"	Grit	Hole Configuration	Price /Each
NY202	AB86824	6	80	600LG	2.31
NY203	AB86825	6	120	600LG	1.92
NY205	AB64259	6	150	600LG	1.92
NY761	AB64265	6	180	600LG	1.92
NY204	AB64271	6	220	600LG	1.92
NY207	AB47098	6	240	600LG	1.92
NY206	AB47082	6	320	600LG	1.92
NY208	AB05059	6	400	600LG	1.92
NU579	AB86820	6	80	600Z	1.91
NU576	AB86821	6	120	600Z	1.61
NV703	AB87041	6	150	600Z	1.61
NU577	AB87040	6	180	600Z	1.61
NV192	AB87089	6	220	600Z	1.61
NV691	AB47096	6	240	600Z	1.61
NV193	AB47099	6	320	600Z	1.61
NV693	AB05056	6	400	600Z	1.61

*Priced per package of 50

KLETON



CANADA'S LEADING MATERIAL HANDLING SUPPLIER

FILE BELTS

Typical Applications

- Light weld removal and blending
- Shape and contour sanding
- Surface preparation prior to coating and plating
- Removing cutting tool marks from moulds and dies
- General clean-up and finishing



NORTON SG BLAZE R980P BELTS

- SG ceramic abrasive grain lasts 50% to 200% longer on mild and carbon steel, stainless, cobalt, chrome, inconel and titanium
- Cuts 20% faster than the current generation of grinding belts, longer belt life, better metal integrity
- Improved Y-wt polyester waterproof cloth backing, significantly improved belt life due to better grain adhesion
- Improved resin bond system, improved grain-retention, cooler cutting during the life of the belt



NORTON

Model No.	Mfg. No.	W"	Size x	L"	Grit	Price /Each
NR091	69957398018	1/2	x	12	40	2.74
NR092	69957698019	1/2	x	12	60	2.65
NR093	69957398020	1/2	x	12	80	2.59
NR094	69957398021	1/2	x	18	40	2.97
NR095	69957398022	1/2	x	18	60	2.82
NR096	69957398023	1/2	x	18	80	2.70
NR097	69957398024	1/2	x	24	40	3.30
NR098	69957398025	1/2	x	24	60	3.07
NR099	69957398026	1/2	x	24	80	2.82
NR100	69957398027	3/4	x	18	40	3.34
NR101	69957398028	3/4	x	18	60	3.14
NR102	69957398029	3/4	x	18	80	2.93

NORZON PLUS R823P BELTS

- Premium, self-sharpening zirconia alumina abrasive
- Aggressive, rapid cut rate, strong grain adhesion, longer life
- Waterproof for use on a broad range of materials
- Strong X-wt polyester backing, for moderate to heavy pressure applications
- Ideal on stainless steel



NORTON

Model No.	Mfg. No.	W"	Size x	L"	Grit	Price /Each
NZ178	78072728745	1/2	x	12	60	1.57
NZ179	78072728744	1/2	x	12	80	1.37
NZ180	78072728742	1/2	x	12	120	1.10
NZ181	78072728569	1/2	x	18	60	1.61
NZ182	78072728568	1/2	x	18	80	1.57
NZ183	78072728567	1/2	x	18	120	1.24
NZ184	78072728564	1/2	x	24	60	1.65
NZ185	78072728566	1/2	x	24	80	1.61
NZ187	78072728565	1/2	x	24	120	1.50
NZ188	78072709590	3/4	x	18	60	1.88
NZ189	78072758953	3/4	x	18	80	1.79
NZ194	78072728583	1	x	30	60	3.36
NZ195	78072728582	1	x	30	80	3.11

METALITE R228 BELTS

- Aluminum oxide abrasive
- Aggressive cutting; resistant to heat
- Strong X-wt rayon backing
- For metal and wood



NORTON

Model No.	Mfg. No.	W"	Size x	L"	Grit	Price /Each
NV700	78072732112	3/8	x	13	Coarse, P60	1.07
NV701	78072771323	3/8	x	13	Coarse, P80	0.97
NZ410	78072727557	1/2	x	12	40	1.07
NZ411	78072727555	1/2	x	12	60	1.07
NZ412	78072727554	1/2	x	12	80	0.97
NZ414	78072727552	1/2	x	12	120	0.87
NZ415	78072727561	1/2	x	18	40	1.10
NZ416	78072727560	1/2	x	18	60	1.08
NZ417	78072727559	1/2	x	18	80	1.07
NZ418	78072727558	1/2	x	18	120	0.97
NZ419	78072727568	1/2	x	24	40	1.14
NZ421	78072727566	1/2	x	24	60	1.14
NZ422	78072727565	1/2	x	24	80	1.08
NZ423	78072727564	1/2	x	24	120	1.14
NZ424	78072727573	3/4	x	20-1/2	40	1.42
NZ425	78072727571	3/4	x	20-1/2	60	1.39
NZ426	78072727570	3/4	x	20-1/2	80	1.31
NZ427	78072727569	3/4	x	20-1/2"	100	1.27
NZ428	78072727575	3/4	x	20-1/2	120	1.27
NZ429	78072727579	1	x	30	80	2.16
NZ430	78072727577	1	x	30	120	2.37

PORTABLE BELTS

Typical Applications

- Grinding and finishing of all metals
- Blending of welds
- Sanding and finishing of wood
- Glass seaming and polishing

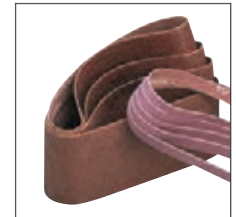

METALITE R228 BELTS

- Aluminum oxide abrasive
- Aggressive cutting; resistant to heat
- Strong X-wt cotton backing
- For metal and wood

NORTON

Model No.	Mfg. No.	W"	Size x	L"	Grit	Price /Each
NZ283	78072727927	3	x	21	40	3.25
NZ284	78072727926	3	x	21	50	3.13
NZ285	78072727925	3	x	21	60	3.04
NZ286	78072727924	3	x	21	80	2.90
NZ287	78072727923	3	x	21	100	2.77
NZ288	78072727922	3	x	21	120	2.77
NZ289	78072781847	3	x	24	36	3.70
NZ290	78072727937	3	x	24	40	3.47
NZ291	78072727936	3	x	24	50	3.30
NZ292	78072727935	3	x	24	60	3.25
NZ293	78072727934	3	x	24	80	3.11
NZ294	78072727933	3	x	24	100	2.97
NZ295	78072727932	3	x	24	120	2.97
NZ302	78072780438	4	x	24	36	6.25
NZ303	78072727947	4	x	24	40	5.61
NZ304	78072727946	4	x	24	50	5.42
NZ305	78072727945	4	x	24	60	5.25
NZ306	78072727944	4	x	24	80	4.94
NZ307	78072727943	4	x	24	100	4.77
NZ308	78072727942	4	x	24	120	4.77

ABRASIVES



CLOTH BELT 767F

- Delivers long-lasting high performance and versatility at a value price
- Contains 3M Precision-Shaped Grain
- Proven to outperform traditional alumina zirconia coated abrasives
- This belt is a YF-Weight polyester backing that excels in medium to high pressure applications on carbon and mild steel, stainless steel, and other substrates
- Abrasive Material: Ceramic



Model No.	Mfg. No.	Grit	Width	Length	Price /Each
NY479	AB73079	36+	3"	132"	26.61
NY454	AB72606	60	3"	132"	22.42
NY455	AB73649	80	3"	132"	22.42
NY456	AB73656	120	3"	132"	20.02

777F CLOTH BELT

- 3M™ ceramic aluminum oxide grain blend surpasses aluminum oxide abrasives in cut-rate
- Durable ceramic/aluminum oxide blend extends belt life, producing more parts per belt and requiring fewer belt changes
- Heavyweight polyester backing supports high-pressure, tough applications and can be run wet or dry
- Contains a grinding aid to reduce heat and increase performance when used stainless steel and other exotic metals
- Long life
- Fast cutting



Model No.	Mfg. No.	Grit	Width	Length	Price /Each
NU341	AB84409	40	1/2"	18"	3.84
NU338	AB80551	60	1/2"	18"	3.54
NU337	AB80232	80	1/2"	18"	3.54
NU340	AB84304	120	1/2"	18"	3.43
NU359	AM39061	180	1/2"	18"	5.36

CUBITRON™ II 984F ABRASIVE BELT

- To be used with back stands, bench top motors, centreless grinders, cylindrical grinders, disc sanders, edge sanders, file belt sanders, inline sanders, manual back stands, pressure assist back stands and wide belt sanders
- 3M® precision-shaped ceramic grain continuously fractures into sharp points that cut exceptionally fast, helping increase productivity
- Engineered to run cooler, reducing metal discolouration/oxidation and the chance of heat related stress cracks
- 3M® precision-shaped ceramic grain requires less pressure, which means less operator fatigue
- YF-weight backing excels in medium to high-pressure stainless steel, cobalt chrome and nickel alloy applications
- Abrasive Material: Ceramic
- Backing Weight: YF-Weight
- Backing Material: Polyester
- Colour: Orange



Model No.	Mfg. No.	Grit	Width	Length	Price /Each
NU310	AB27511	36	1/2"	18"	5.30
NU323	AB55041	60	1/2"	18"	5.10
NV720	AB55064	36	3/4"	18"	5.81
NV747	AM39679	36	1"	18"	7.72
NU324	AB55048	80	1/2"	18"	4.99
NV717	AB27512	36	1/2"	24"	5.68
NV731	AB55031	60	1/2"	24"	5.41
NV739	AB55054	80	1/2"	24"	5.24

CLOTH BELT 241D

- Tube-shaped band fits inner and outer contours to remove parting lines, imperfections and burrs
- X-weight cloth backing withstands heavy sanding and grinding
- Resin bond withstands high heat and pressure
- Tough aluminum oxide abrasive mineral cuts fast and performs well on many substrates
- Abrasive Material: Aluminum Oxide



Model No.	Mfg. No.	Grit	Width	Length	Price /Each
BP033	AB66616	36	3"	24"	5.21
BP034	AB66604	40	3"	24"	4.98
BP035	AB66617	50	3"	24"	4.60
BP037	AB66611	80	3"	24"	3.88
BP031	AB66607	100	3"	24"	3.62
BP032	AB66608	120	3"	24"	3.62
BP043	AB66610	P60	4"	24"	7.57
BP044	AB66611	P80	4"	24"	6.49

SCOTCH-BRITE™ DURABLE FLEX BELT

- Tough, non-woven belt is effective for deburring, blending and cleaning
- Higher flexibility resists "chunking" and performs well on belt sanders with small contact wheels
- Low-stretch backing provides aggressive conditioning capability
- Provides controlled cut to eliminate gouging and leaves a burr free finish
- Abrasive Material: Aluminum Oxide



Priced per Case

Model No.	Mfg. No.	Grit	Width	Length	Qty /Case	Price /Each
NY486	SB64467	Fine	1/2"	18"	20	252.38
NY487	SB64468	Fine	1/2"	24"	20	336.51
NY488	SB64470	Fine	3-1/2"	15-1/2"	10	536.68
NY490	SB64458	Medium	1/2"	18"	20	252.38
NY489	SB64457	Medium	1/2"	12"	20	168.25
NY491	SB64459	Medium	1/2"	24"	20	336.51
NY494	SB64460	Medium	3/4"	18"	20	378.57
NY493	SB64462	Medium	3"	132"	5	738.94
NY492	SB64461	Medium	3-1/2"	15-1/2"	10	536.68
NY481	SB64474	Coarse	1/2"	12"	20	168.25
NY482	SB64475	Coarse	1/2"	18"	20	252.38
NY483	SB64476	Coarse	1/2"	24"	20	336.51
NY485	SB64477	Coarse	3/4"	18"	20	378.57
NY484	SB64478	Coarse	3-1/2"	15-1/2"	10	536.68

TAKING THE STRESS OUT OF SPILLS

ZENITH
Safety Products



STATIONARY BELTS

Typical Applications

- Benchstand and backstand belts
- Grinding and deburring of all metals
- Heavy stock removal
- Blending, dimensioning and shaping
- Polishing

NORZON PLUS R823P BELTS

- Premium self-sharpening zirconia alumina abrasive, aggressive, rapid cut rate
- Strong X-wt polyester backing; waterproof, greater flexibility, ideal for heavy pressure applications



NORTON

Model No.	Mfg. No.	W"	Size x L"	Grit	Price /Each
NZ196	78072728596	1	x 42	60	3.39
NZ197	78072728594	1	x 42	80	3.22
NZ198	78072728592	1	x 42	100	3.04
NZ199	78072728590	1	x 42	120	3.04
NZ200	78072728586	1	x 42	180	3.04
NZ215	78072728827	4	x 36	60	9.01
NZ217	78072728821	4	x 36	120	7.91
NZ218	78072728937	6	x 48	60	15.20
NZ219	78072728935	6	x 48	80	13.70
NZ220	78072728933	6	x 48	100	13.30
NZ221	78072728931	6	x 48	120	13.30

METALITE R228 BELTS

- Aluminum oxide abrasive
- For a wide range of metalworking applications
- Strong X-wt cotton backing, aggressive cutting/resistant to heat



NORTON

Model No.	Mfg. No.	W"	Size x L"	Grit	Price /Each
NZ309	78072720910	1	x 42	40	2.94
NZ310	78072720905	1	x 42	50	2.90
NZ311	78072720900	1	x 42	60	2.85
NZ312	78072720895	1	x 42	80	2.70
NZ313	78072720890	1	x 42	100	2.64
NZ314	78072720885	1	x 42	120	2.64
NZ315	78072720880	1	x 42	150	2.64
NZ316	78072720875	1	x 42	180	2.64
NZ317	78072720871	1	x 42	220	2.64
NZ318	78072720870	1	x 42	240	2.64
NZ319	78072720865	1	x 42	320	2.64
NZ354	78072722110	4	x 36	36	7.87
NZ355	78072722105	4	x 36	40	10.40
NZ356	78072722100	4	x 36	50	10.00
NZ357	78072722095	4	x 36	60	9.61
NZ358	78072722090	4	x 36	80	9.16
NZ359	78072722085	4	x 36	100	8.93
NZ360	78072722080	4	x 36	120	8.93
NZ361	78072722079	4	x 36	150	6.48
NZ362	78072722075	4	x 36	180	6.48
NZ363	78072722071	4	x 36	320	6.48
NZ372	78072722585	6	x 48	40	18.50
NZ373	78072722580	6	x 48	50	17.70
NZ374	78072722575	6	x 48	60	17.00
NZ375	78072722570	6	x 48	80	12.40
NZ376	78072722565	6	x 48	100	15.70
NZ377	78072722560	6	x 48	120	15.70
NZ378	78072722555	6	x 48	150	12.00
NZ379	78072722550	6	x 48	180	12.00
NZ380	78072722546	6	x 48	220	12.00
NZ381	78072722545	6	x 48	240	12.00
NZ382	78072722543	6	x 48	320	12.00

SPIRAL BANDS

Typical Applications

- Deburring
- Polishing
- Surface preparation

Features & benefits

- Spiral construction avoids shadow marks and provides smooth cutting action
- Achieve close tolerances when finishing curved or contoured areas

SPIRAL BANDS

- Aluminum oxide resin bond



NORTON

Model No.	Mfg. No.	Size"	Grit	Price Each
BZ251	08834196068	1/2 x 1/2	60	110.00
BZ288	08834196179	1/2 x 1/2	80	72.40
BZ252	08834196069	1/2 x 1/2	120	72.40
BZ307	08834196212	1/2 x 1	60	77.00
BZ309	08834196215	1/2 x 1	80	77.00
BZ305	08834196210	1/2 x 1	120	119.00
BZ401	08834196554	3/4 x 1	60	90.80
BZ328	08834196249	3/4 x 1	80	90.80
BZ244	08834196057	3/4 x 1	120	136.00
BZ257	08834196074	1 x 1	80	84.70
BZ278	08834196167	1 x 1	100	124.00
BZ286	08834196177	1 x 1	120	84.70
BZ247	08834196060	1 x 1 1/2	60	98.50
BZ274	08834196162	1 x 1 1/2	80	98.50
BZ443	08834196677	1 x 1 1/2	120	139.00
BZ289	08834196181	2 x 2	80	229.00
BZ298	08834196193	2 x 2	100	219.00
BZ412	08834196585	2 x 2	120	229.00
BZ296	08834196188	3 x 3	60	285.00
BZ272	08834196159	3 x 3	80	285.00
BZ407	08834196572	3 x 3	120	379.00

CLOTH BELT 241D

- Tube-shaped band fits inner and outer contours to remove parting lines, imperfections and burrs
- X-weight cloth backing withstands heavy sanding and grinding
- Resin bond withstands high heat and pressure
- Tough aluminum oxide abrasive mineral cuts fast and performs well on many substrates
- Abrasive Material: Aluminum Oxide



3M

Model No.	Mfg. No.	Size"	Grit	Price /Each
BP054	AB66625	6 x 48	36	18.17
BP055	AB66629	6 x 48	40	17.43
BP056	AB66630	6 x 48	50	16.11
BP057	AB66631	6 x 48	60	16.31
BP058	AB66634	6 x 48	80	14.80
BP053	AB66636	6 x 48	120	13.93



SHOP CLOTH ROLLS

Typical Applications

- Polishing lathe turnings, rolls and cylinders
- Light deburring
- Blending machine tool marks
- Removing rust and scale
- Fine sanding and polishing

METALITE K225 CLOTH SHOP ROLLS

- For general purpose metalworking applications
- Premium P-graded aluminum oxide abrasive produces greater cut rate
- Flexible J-wt cotton backing offers superior conformability to complex surfaces and better finishes
- Advanced full resin bond system offers exceptional grain adhesion for longer life



314D PROFESSIONAL CLOTH SHEETS

- Cleaning metal prior to soldering or welding
- Repairing and blending metal finishes and removing stamping marks
- Fine sanding and polishing
- Removing rust, scale and other contaminants
- Hand or machine deburring



Model No.	Mfg. No.	Grit	Price /Each
1" X 50 YARD			
NS204	66261058716	40	45.40
NS205	66261127728	50	45.20
NS206	66261127729	60	44.40
NS212	66261126276	80	46.50
NS213	66261126275	100	45.00
NS214	66261126274	120	45.00
NS215	66261126273	150	45.00
NZ846	66261126270	240	45.00
NZ847	66261126268	320	45.00
NZ887	66261126267	400	45.00
1 1/2" X 50 YARD			
NZ888	66261058715	40	64.50
NZ890	66261127731	60	62.00
NZ891	66261126288	80	65.10
NZ892	66261126287	100	62.90
NZ893	66261126286	120	62.90

Model No.	Mfg. No.	Grit	Price /Each
1 1/2" X 50 YARD			
NZ894	66261126285	150	62.90
NZ951	66261126284	180	62.90
NZ953	66261126282	240	62.90
NZ955	66261126280	320	62.90
NZ957	66261126279	400	62.90
2" X 50 YARD			
NZ959	66261058714	40	83.70
NZ995	66261127732	50	83.00
NZ996	66261127733	60	81.40
NS048	66261126299	80	82.80
NZ997	66261126298	100	80.00
NS049	66261126297	120	80.00
NS050	66261126296	150	80.00
NS051	66261126295	180	80.00
NZ998	66261126293	240	80.00
NZ999	66261126291	320	80.00
NR001	66261126290	400	80.00

9" X 11" SHEETS

Model No.	Mfg. No.	Grit	Price /Each
BP672	60333	50X	1.91
BP673	60334	60X	1.79
BP671	60342	80J	1.57
BP664	60343	100J	1.51
BP665	60344	120J	1.51
BP666	60345	150J	1.51
BP667	60346	180J	1.51
BP668	60347	220J	1.51
BP669	60348	240J	1.51
BP670	60349	280J	1.51

ROLLS

Model No.	Mfg. No.	Grit	Price /Each
1" X 50 YARD			
BP660	60326	50X	37.00
BP662	60325	60X	34.87
BP657	60686	80J	30.57
BP643	60687	100J	28.83
BP645	60688	120J	28.83
BP647	60689	150J	28.83
BP649	60690	180J	28.83
BP651	60691	220J	28.83
BP653	60692	240J	28.83
BP655	60693	280J	28.83

ROLLS

Model No.	Mfg. No.	Grit	Price /Each
1 1/2" X 50 YARD ROLLS			
BP624	60327	50X	55.47
BP625	60328	60X	52.32
BP623	60697	80J	45.90
BP616	60698	100J	43.03
BP617	60699	120J	43.03
BP618	60700	150J	43.03
BP619	60701	180J	43.03
BP620	60702	220J	43.03
BP621	60703	240J	43.03
BP622	60704	280J	43.03
2" X 50 YARD ROLLS			
BP659	60329	40X	79.54
BP661	60330	50X	73.92
BP663	60331	60X	69.71
BP658	60708	80J	61.12
BP644	60709	100J	57.38
BP646	60710	120J	57.38
BP648	60711	150J	57.38
BP650	60712	180J	57.38
BP652	60713	220J	57.38
BP654	60714	240J	57.38
BP656	60715	280J	57.38

R243 HANDY SANDING ROLL

- Quality P-graded aluminum oxide abrasive grain delivers fast cut rate and consistent finish on metals
- Smooth, flexible backing provides superior conformability to complex surfaces and better finishes
- Advanced full resin bond system provides exceptional grain adhesion for longer life on aluminum, fiberglass, composites, hard woods and soft woods
- Used for polishing lathe turnings, rolls and cylinders, light deburring, blending machine tool marks, removing rust and scale, and fine sanding and polishing
- Abrasive Material: Aluminum Oxide
- Backing Weight: J-Weight
- Backing Type: Cloth
- Length of Roll: 150'



Model No.	Mfg. No.	Grit	Width"	Price /Each
NV106	66261136178	60	1	32.40
NV107	66261136179	80	1	27.20
NV108	66261136180	100	1	26.30
NV109	66261136181	120	1	26.30
UAJ256	66261136182	150	1	26.30
NV110	66261136186	180	1	26.30
NV111	66261136187	240	1	26.30
NV112	66261136188	320	1	26.30
NV266	66261136192	80	1-1/2	38.00
NV113	66261136195	120	1-1/2	36.80
NV442	66261136196	150	1-1/2	36.80
NV353	66261136199	180	1-1/2	36.80
NV145	66261136201	320	1-1/2	36.80

Model No.	Mfg. No.	Grit	Width"	Price /Each
NV114	66261136203	60	2	57.50
NV115	66261136204	80	2	48.30
NV116	66261136205	100	2	46.80
NV117	66261136206	120	2	46.80
NV141	66261136207	150	2	46.80
NV118	66261136208	180	2	46.80
NV119	66261136209	240	2	46.80
NV120	66261136210	320	2	46.80
NV144	66261136211	400	2	46.80

SANDPAPER, CLOTH SHEETS

Typical Applications

- Scouring and light deburring
- Scale and rust removal
- Blending machine tool marks
- Fine sanding and polishing

METALITE K225 9" X 11" SHEETS

- Premium P-graded aluminum oxide abrasive
- Advanced full resin bond system offers exceptional grain adhesion for longer life
- Flexible J-wt cotton backing, for superior conformability to complex surfaces and better finishes



NORTON

Model No.	Mfg. No.	Grit	Price /Each
NR103	66261058713	40	2.44
NR104	66261101862	50	2.25
NR105	66261101861	60	2.08
NZ455	66261126340	80	1.81
NZ456	66261126339	100	1.65
NZ457	66261126338	120	1.65
NZ458	66261126337	150	1.65
NZ459	66261126336	180	1.65
NZ460	66261126335	220	1.65
NZ461	66261126334	240	1.65
NZ462	66261126333	280	1.65
NZ463	66261126332	320	1.65
NZ464	66261126331	400	1.65
NZ465	66261126330	600	1.65

SANDPAPER, PAPER SHEETS

Typical Applications

- Light duty, metal sanding
- Primer sanding, defect removal from painted surfaces
- Filler sanding
- Sanding and finishing of composites and fibreglass
- Bare wood sanding
- Sanding between sealer coats

NO-FIL ADALOX A275 9" X 11" SHEETS

- Premium P-graded, heat-treated aluminum oxide abrasive
- Unique fibre-reinforced, B-wt latex-saturated backing, can be used wet
- Water-based serrated, non-pigmented, No-Fil coating, provides maximum load resistance and extended life; no colour transfer to work



NORTON

Model No.	Mfg. No.	Grit	Price /Each
NZ431	66261131634	80	1.34
NZ432	66261131633	100	1.22
NZ433	66261131632	120	1.22
NZ434	66261131631	150	1.22
NZ435	66261131630	180	1.22
NZ436	66261131629	220	1.22
NZ437	66261131628	240	1.22
NZ438	66261131627	280	1.22
NZ439	66261131626	320	1.22
NZ440	66261131624	400	1.22
NZ441	66261131623	500	1.22
NZ442	66261131622	600	1.22
NZ443	66261131621	800	1.22

BLUE-BAK T414 WATERPROOF 9" X 11" SHEETS

- Sharp silicon carbide abrasive, exceptional finishes in wet applications
- Strong resin bond, longer life in wet applications
- High strength B-wt waterproof paper backing, extremely flexible
- Environmentally stable; resists humidity-caused curling

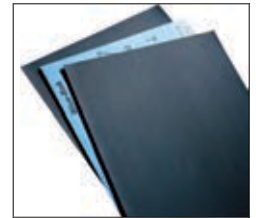

NORTON

Model No.	Mfg. No.	Grit	Price /Each
NZ447	66261139367	220	1.41
NZ448	66261139366	240	1.41
NZ449	66261139365	280	1.41
NZ450	66261139364	320	1.41
NZ451	66261139363	360	1.41
NZ452	66261139362	400	1.41
NZ453	66261139361	500	1.41
NZ454	66261139360	600	1.41

NO-FILL DURITE A475 9" X 11" SHEETS

- P-graded silicon carbide abrasive offers easy penetration of the hardest surfaces
- Water-based stearate, non-pigmented, no-fill coating resists loading for longer usable product life, no color transfer to work
- Fibre-reinforced latex paper backing provides flexibility and resistance to tearing
- Ideal choice for gel coats, hard composite substrates, abrasion-resistant coatings and woodworking application



NORTON

Model No.	Mfg. No.	Grit	Price /Each
NR856	66254487393	P80-B	1.11
NR857	66254487394	P100-B	0.99
NR858	66254487395	P120-B	0.99
NR859	66254487396	P150-B	0.99
NR860	66254487397	P180-B	0.99
NR861	66254487398	P220-B	0.99
NR862	66254487399	P240-B	0.99
NR863	66254487400	P320-B	0.99

GARNET A511 9" X 11" SHEETS

- Natural garnet grain
- Excellent for soft woods, consistent finishes, A-weight paper
- Designed for heavy-duty to light-duty hand and machine sanding



NORTON

Model No.	Mfg. No.	Grit	Price /Each
NR114	66261101505	80	1.01
NR115	66261101500	100	0.85
NR116	66261101495	120	0.85
NR117	66261101490	150	0.85
NR118	66261101489	180	0.85
NR119	66261101488	220	0.85



HAND PADS

Typical Applications

- Light to heavy duty cleaning
- Deburring
- Blending
- Polishing
- Finishing

Features & benefits

- Made of a nonwoven nylon web impregnated with abrasive grain and resin
- A variety of abrasives, grit sizes and backing materials provides an extensive and superior product offering
- Can be used instead of steel wool
- Non-loading, non-rusting, waterproof and solvent resistant

SCOTCH-BRITE™ HAND PADS

- Excellent products for hand finishing, polishing, cleaning, blending, deburring of wood, metals and composites
- Ideal for wood finishing, paint preparation and general cleaning
- 6" x 9" sheets
- Can be used dry or with water or solvents



Model No.	Type of Pad	Colour	Finish	Price /Each
BP486	Heavy-duty	Tan	Coarse	4.82
BP482	Blending	Grey	Medium	3.26
BP484	General purpose	Maroon	Very Fine	1.56
BP492	Ultra fine	Light Grey	Ultra fine	1.57
BP488	Cleaning	White	Cleaning	2.13
NC871	General purpose #96	Green	Scouring	1.30

SCOTCH-BRITE™ PRODUCTION HAND PADS

- Higher rate of cut, longer life and better finish
- Use on aluminum, stainless steel, plastics, wood and fiberglass
- Ideal for paint preparations, surface blending and scuffing
- Comes in 6" x 9" pads which tear easily into 4 1/2" x 6" sheets

Model No. BP490
Price/Each \$1.87



BEAR-TEX HAND PADS

- Flexible, gentle action and resilient construction
- Conform to work surface and easily remove flashing or burrs without affecting dimension of work piece
- Non-loading, non-rusting, constant supply of new cutting edges, no workpiece contamination



NORTON

Model No.	Colour	Description	Abrasive	Grit	Qty /Pkg.	Price /Each
NZ811	White	Light-Duty Cleaning Pad	Non-Abrasive	-	60	1.87
NZ812	Grey	Clean and Finish Pad	Silicon Carbide	Ultra Fine	60	1.67
NZ813	Light Green	Food Pro Pad	Aluminum Oxide	Very Fine	60	0.71
NS046	Dark Tan	Heavy-Duty Pad	Aluminum Oxide	Medium	40	4.30
NZ814	Grey	Metal Blend Pad	Silicon Carbide	Medium	40	2.79
NS045	Maroon	General Purpose Pad	Aluminum Oxide	Very Fine	60	1.65
NZ815	Grey	Final Shine Pad	Silicon Carbide	Micro Fine	60	1.67
NZ816	Maroon	Long Life Pad	Aluminum Oxide	Very Fine	60	1.67
NZ817	Green	Scouring Pad	Aluminum Oxide	Very Fine	60	1.67
NZ818	Maroon	General Purpose Perforated Pad	Aluminum Oxide	Very Fine	60	1.74
NZ820	-	Hand Pad Holder	-	-	10	8.01

SCOTCH-BRITE™ SHEET ROLLS

- Tough, highly flexible, sharp cutting abrasive
- High flexibility makes for easy cleaning and finishing surfaces by hand
- 8" x 4" sheets come packaged in rolls of 60 sheets
- Purple colour sheets provide a Very Fine finish, and grey sheets provide an Ultra Fine finish

Model No. BP001
Very Fine Roll
Price/Each \$75.87

Model No. BP002
Ultra Fine Roll
Price/Each \$75.87



SANDING SPONGES

- Sponges form perfectly to corners, contours and flat surfaces
- Can be used on all surfaces, from wood, metal and plastic, to coated or painted surfaces
- Sponges are all 4 1/2" x 5 1/2" in size and have a soft sponge in the centre



Model No.	Grit	Qty Price /Each
BP629	Medium	5.08
BP628	Fine	5.08
BP630	Super Fine	5.08

HAND PADS

- Non-woven, synthetic fibres, bonded together with specially formulated resins and impregnated throughout the web with mineral grain creating an open, three dimensional structure
- Designed for light duty cleaning, polishing, scuffing, finishing and for heavy duty paint, rust and corrosion removal
- Can be used for dry scuffing and finishing or may be used with water or chemical solvents
- Flexible and strong
- 6" x 9"

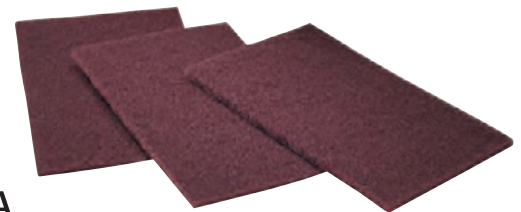

AURORA
TOOLS

Model No.	Description	Finish	Qty /Pkg	Qty Price /Each
NU022	Tan heavy duty	Coarse	10	2.39
NU023	Green industrial	Scouring	20	1.14
NU024	Maroon GP	Medium	20	1.14
NU025	Grey ultra fine	Ultra-fine	20	1.34
NU026	White non-abrasive	Non-abrasive	20	1.23

ROLLS

Typical Applications

- Light deburring
- Cleaning
- Finishing
- Applying decorative finishes

Features & benefits

- Rolls may be cut for use in jitterbug sanding or on hand sanding applications
- Rolls have the durability for indexing machine applications

CLEAN & STRIP

Typical Applications

- Removal of paint and epoxy coating, surface rust and residue, corrosion, light weld splatter, dirt, mill scale and other similar surface contaminants
- Surface prep before coatings are applied
- Surface prep before welding; cleaning and conditioning afterwards
- Applying fine finishes

Features & benefits

- A web of strong synthetic fibres and quality abrasive, bonded together by a smear-resistant adhesive for cleaning, conditioning, and finishing a multitude of materials, quickly and easily with little loading

SCOTCH-BRITE™ CLEAN & FINISH ROLLS

- Used for final hand cleaning, blending and finishing
- Can be cut to desired length for oscillating sanders



Model No.	Mfg. No.	Size	Colour	Finish	Price /Each
BP604	00264	4" x 30'	Maroon	Medium	150.75
BP612	00274	6" x 30'	Maroon	Medium	225.43
BP603	00265	4" x 30'	Maroon	Fine	113.89
BP611	00275	6" x 30'	Maroon	Fine	163.76
BP605	00266	4" x 30'	Maroon	Very fine	94.18
BP609	00270	4" x 30'	Grey	Very fine	96.06
BP613	00276	6" x 30'	Maroon	Very fine	139.09
BP608	69006	4" x 30'	Grey	Ultra fine	94.18
BP607	69009	4" x 30'	Grey	Super fine	94.18
BP606	69010	4" x 30'	White	Cleaning	94.18

MINI-MANDRELS

- Use with 1" x 1 1/2" Scotch-Brite™ material to fit tight areas
- Mandrel is 2 7/8" long with a 1/4" shank

Model No. **BP504**
Price/Each \$27.55



CUT 'N POLISH ROLLS

- Outlast and outperform emery cloth and utility rolls around angles, corners, odd shapes, and inside/outside diameters
- Used for general cleaning, deburring odd shapes and stropping pipe prior to soldering or welding
- Tan colour and medium finish

Model No. **BP614** 1" x 30' Roll
Price/Each \$59.62

Model No. **BP615** 2" x 30' Roll
Price/Each \$114.40



BEAR-TEX FAST CUT ROLLS

- Premium aluminum oxide grain provides clean cutting and long lasting
- Fast initial cut, less pressure needed
- Improved base adhesion, improved cut rate



Model No.	Colour	Grit	Size	Price /Each
NZ821	Tan	Medium	4" x 30'	192.00
NZ822	Maroon	Very Fine	4" x 30'	77.10
NZ823	Grey	Very Fine	4" x 30'	73.50

BEAR-TEX

Rapid strip discs and depressed center wheels

- Open web constructions provides fast cutting action with very little loading
- Follow difficult part profiles, easy cleaning of uneven surfaces
- Thick, strong, synthetic fibres and extra coarse grit
- Quick cleaning and conditioning of surfaces
- Silicon carbide abrasive, extra coarse
- Ideal for surface preparation, conditioning and cleaning, removal of rust, paint, weld splatter, etc.



Model No.	Size"	Max RPM	Qty /Pkg.	Price /Each
TYPE 1 - BEAR-TEX RAPID STRIP WHEELS				
NZ842	4 x 1/4	8000	25	16.80
NZ843	4 x 1/2	8000	25	16.80
NZ844	6 x 1/2	5500	15	27.20
TYPE 27 - BEAR-TEX RAPID STRIP CLEANING DISCS				
NS047	4 1/2 x 7/8	11000	10	19.00
NS136	7 x 7/8	8000	10	30.10

SCOTCH-BRITE™ CLEAN & STRIP DISCS (SILICON CARBIDE - EXTRA COARSE)

- Tough open web ideal for weld cleaning, paint and coatings removal
- Faster and safer than wire brushes



Model No.	Dia."	Max. RPM	Price /Each
BP252	4 x 1/2	6000	14.55
BP254	6 x 1/2	4000	23.23
BP255	8 x 1/2	3000	36.33

MANDRELS

- Furnished complete with washers to fit available disc sizes

Model No.	Mfg. No.	Size"	Price /Each
BP502	933	2	12.57
BP503	934	3 1/16	41.87





SURFACE BLENDING

Typical Applications

- Removing surface defects
- Removing light edge burrs, parting lines or flashing
- Removing rust, oxides, corrosion, paints and scale
- Cleaning molds
- Blending mill marks, tool marks, uneven edges and coated abrasive finish

Features & benefits

- Discs and belts perform well under a wide range of applications: from removing engine gaskets, and deburring of aluminum and steel, to finishing nickel alloy turbine blades

SCOTCH-BRITE™ COATING REMOVAL DISCS

Made for right angle tools from aggressive clean and strip web. Non-loading design ideal for removing rust and coatings.

- Hook and loop backing easily attaches to 3M disc pad holder
- Silicon carbide - extra coarse



Model No.	Dia."	Grit	Max. RPM	Price /Each
BP272	4 1/2	Extra coarse	12 000	19.22
BP274	5	Extra coarse	10 000	21.19
BP275	7	Extra coarse	6 000	35.60

HOOK & LOOP SCOTCH-BRITE™ SURFACE CONDITIONING DISCS

Scotch-Brite™ surface conditioning discs are best for finishing, cleaning and light deburring on flat metal surfaces. Attach and remove easily to 3M hook & loop back up pads.

Used with the

following hand tools:

- Right angle
- Random orbital
- Dual action



Model No.	Dia."	Grit	Colour	Max. RPM	Price /Each
BP357	2	Coarse	Brown	23 000	1.78
BP359	2	Medium	Maroon	23 000	1.78
BP363	3	Coarse	Brown	20 000	3.64
BP376	4	Coarse	Brown	13 000	4.67
BP380	4	Very Fine	Blue	13 000	4.54
BP369	4 1/2	Coarse	Brown	13 000	5.66
BP371	4 1/2	Medium	Maroon	13 000	4.94
BP381	5	Coarse	Brown	10 000	6.39
BP383	5	Medium	Maroon	10 000	5.30
BP390	7	Medium	Maroon	6 000	8.21

HOOK & LOOP DISC PAD HOLDERS

For use with 3M Scotch-Brite™ surface conditioning and coating removal discs.



Model No.	Size"	Shank	Max. RPM	Price /Each
SHANK MOUNTED DISC PAD HOLDERS				
BP207	2	1/4"	23 000	13.62
BP208	3	1/4"	20 000	17.35
BP209	4	1/4"	13 000	19.17
BP206	5	5/16"-24	10 000	55.62
HUB MOUNTED DISC PAD HOLDERS				
BP199	4	5/8"-11	13 000	54.47
BP201	4 1/2	5/8"-11	13 000	54.47
BP202	5	5/8"-11	10 000	54.47
BP204	7	5/8"-11	6 000	54.47



BP206



BP199

SCOTCH-BRITE™ DISCS

Premium Scotch-Brite™ surface conditioning non-woven web provides a burr-free decorative finish.

Removes grind marks, rust and coatings.



Model No.	Dia."	Grit	Colour	Price /Each
ROLOC™				
BP396	2	Coarse	Brown	1.68
BP397	2	Medium	Maroon	1.68
BP398	2	Very Fine	Blue	1.68
BP400	3	Coarse	Brown	3.13
BP401	3	Medium	Maroon	3.13
BP403	3	Very Fine	Blue	3.13
ROLOC™ TSM				
BP404	2	Coarse	Brown	2.07
BP405	2	Medium	Maroon	2.07
BP406	2	Very Fine	Blue	2.07
BP407	3	Coarse	Brown	4.14
BP408	3	Medium	Maroon	4.14
BP409	3	Very Fine	Blue	4.14

ROLOC™ DISC PADS

Rubber back-up pads are available in different diameters and degrees of hardness for varying grinding applications. Pads are internally threaded to receive any standard 1/4"-20 thread shaft.



Model No.	Size"	Max. RPM	Hardness	Price /Each
BP008	2	25 000	Medium	31.92
BP005	2	25 000	Hard	29.25
BP009	3	18 000	Medium	35.70
BP006	3	20 000	Hard	35.70

ROLOC™ TSM DISC PADS

For use with Roloc™ TSM grinding discs and screw on abrasive discs.



Model No.	Size"	Max. RPM	Hardness	Price /Each
BP517	2	25 000	Medium	41.27
BP516	2	25 000	Hard	43.16
BP518	3	20 000	Hard	50.87

1/4" THREADED SHAFTS

- Needed with all Roloc™ disc pads

Model No. BP013 Price/Each \$5.63

BUFF & BLEND® PRODUCTS

These products are made from an open structure of non-woven fibres impregnated with abrasive particles held together by resin to form a loose webbing. Buff & Blend® products are designed for light duty removal of rust, oxidation and coatings (including paint), without affecting the base material. They are not intended for use on sharp edges or burrs.

GP MATERIAL

- Flexible and conformable
- GP provides a high rate of cut



SURFACE CONDITIONING DISCS

These products provide a more compact structure of non-woven fibres than Buff & Blend® products. Surface conditioning products have a woven fabric (Scrim) imbedded in the nylon structure to provide additional strength and durability for edge work, deburring and efficient blending of all metal types.

FE MATERIAL

- High initial and extended rate of cut
- Very flexible with high edge durability
- Effective on both flat and contoured surfaces



SOCATT® DISCS

Model No.	Size"	Grit	Price /Each
VU676	2	Medium	2.23
VU677	2	Fine	2.09
VU678	2	Very Fine	2.11
VU679	3	Medium	3.68
VU680	3	Fine	3.31
VU681	3	Very Fine	3.31

LOCKIT® DISCS

Model No.	Size"	Grit	Price /Each
VU685	2	Medium	2.24
VU686	2	Fine	2.11
VU687	2	Very Fine	2.21

HP MATERIAL

- Durable and aggressive
- Recommended starting point for deburring applications

Model No.	Size"	Grit	Price /Each
VU697	6 x 1/2	Very Fine	5.83
VU705	8 x 1/2	Very Fine	9.03

SOCATT® DISCS

Model No.	Size"	Grit	Price /Each
NP136	2	Coarse	2.47
NW105	2	Medium	2.47
NP137	2	Very Fine	2.51
NW104	3	Coarse	4.72
NP131	3	Medium	4.72
NP132	3	Very Fine	4.72

LOCKIT® DISCS

Model No.	Size"	Grit	Price /Each
NP138	2	Coarse	2.51
NP139	2	Medium	2.51
NP140	2	Very Fine	2.51
NP133	3	Coarse	4.72
NP134	3	Medium	4.72
NP135	3	Very Fine	4.72

SCOTCH-BRITE EXL™ ROLOC™ UNITIZED WHEELS

- Strong, efficient products for edge deburring and finishing
- Used with 3M Roloc® holder pads on a straight shaft or right angle tool



Model No.	Grit	Finish	Size"	Max. RPM	Price /Each
NW069	6A	Medium	2	22 100	7.50
NW070	2A	Medium	2	22 100	6.24
NW071	2S	Fine	2	22 100	6.24
NW072	6A	Medium	3	15 100	13.22
NW073	2A	Medium	3	15 100	11.01
NW074	2S	Fine	3	15 100	11.04

HOLDER PADS

- With mandrel



FOR SMALL DIAMETER SOCATT® DISCS

Model No.	Dia."	Density	Price /Each
VU601	2	Soft	28.18
VU602	2	Medium	27.04
VU603	2	Firm	32.21
VU605	3	Medium	31.26
VU606	3	Firm	37.23

FOR SMALL DIAMETER LOCKIT® DISCS

Model No.	Dia."	Density	Price /Each
VU611	2	Medium	27.04
VU612	2	Firm	32.21
VU613	3	Soft	34.31
VU614	3	Medium	31.26

COMBI WHEELS

- Made of alternating flaps of coated abrasive and Scotch-Brite™ web
- Aggressive cuts and fine finishes



Model No.	Grit	Size"	Max. RPM	Price /Each
NW066	80	3 x 13/4 x 1/4	8000	49.38
NW067	P120	3 x 13/4 x 1/4	8000	51.61
NW068	P180	3 x 13/4 x 1/4	8500	49.38

ABRASIVES

SCOTCH-BRITE™ SURFACE CONDITIONING FILE BELTS

Premium Scotch-Brite™ surface conditioning non-woven web.

Designed for:

- Cleaning
- Finishing
- Light deburring

Recommended Operating Speeds:

Generally, low speeds are recommended for generating very uniform satin finishes, finishing aluminum alloys without lubricants, and woodworking applications. Higher speeds are recommended when removing imperfections prior to buffing. High belt speed will result in faster cut along with finer finishes.



Application	Recommended SFPM*
Decorative finishing	500-3000
Wood sanding	1200-2700
Deburring	5000-6500

Application	Recommended SFPM*
Cleaning and conditioning	2000-5000
Oxide removal	4500-6500

*Surface feet per minute

SCOTCH-BRITE™ FLAP BRUSHES

- Heavy duty brush excellent for removing handling marks and surface imperfections
- Available on 1/4" shaft (CPFB-S) or Roloc+ attachment system (CPFB-R)



CPFB-R & CPFB-S

Model No.	Size"	Max. RPM	Grit	Price /Each
NW061	2 x 1 x 1/4	12000	Medium	26.37
BP446	3 x 1 3/4 x 1/4	8500	Medium	47.64

CFFB-R & CFFB-S

- Ideal for decorative finishes and light deburring applications
- Available on 1/4" shaft (CFFB-S) or Roloc+ attachment system (CFFB-R)

Model No.	Size"	Max. RPM	Grit	Price /Each
BP442	3 x 1 3/4 x 1/4	8500	Coarse	47.42



Model No.	Size"	Colour	Finish	Price /Each
BP069	1/4 x 24	Blue	Very fine	6.81
BP068	1/4 x 24	Maroon	Medium	6.81
BP067	1/4 x 24	Brown	Coarse	6.81
BP063	1/2 x 18	Blue	Very fine	10.20
BP062	1/2 x 18	Maroon	Medium	10.20
BP061	1/2 x 18	Brown	Coarse	10.21
BP066	1/2 x 24	Blue	Very fine	13.61
BP065	1/2 x 24	Maroon	Medium	13.61
BP064	1/2 x 24	Brown	Coarse	13.62
BP076	3/4 x 18	Blue	Very fine	15.31
BP075	3/4 x 18	Maroon	Medium	15.31
BP074	3/4 x 18	Brown	Coarse	15.33
BP073	3 x 24	Maroon	Medium	57.60
BP071	3 1/2 x 15	Maroon	Medium	43.40
BP070	3 1/2 x 15	Brown	Coarse	43.40

POLISHING & BUFFING WHEEL COMPOUNDS

For use with buffing wheels. All bars are: 2" x 2" x 10" except jewelers rouge: 1 1/4" x 1 1/4" x 6".



Model No.	Bar Type	Description	Price /Each
TT143	Black	Coarse, fast cutting bar for removal of rust and scale from iron and steel	33.30
TT144	Brown Tripoli	General purpose bar for buffing brass and aluminum	45.00
TT149	Green	For fine stainless steel and other metals, general purpose	38.50
TT218	White Rouge Finishing	Provides a bright luster to stainless steel, aluminum, iron, chrome and nickel surfaces	33.90
TT219	Red Jewelers Rouge	Enhances luster of buffed precious metals, gold, sterling, silver, platinum etc.	34.50
TT220	General Purpose	All round general purpose buffing compound	33.90

Stay safe & work confidently with



DEBURRING & MULTI-FINISHING WHEELS

Typical Applications

- Burr and flashing removal
- Surface roughness reduction
- Blending weld areas on stainless steel
- Blending scratch patterns
- Weld polishing
- Removing rust and oxides
- Applying decorative finishes including antique patterns

Features & benefits

- Formed by wrapping and bonding web material impregnated with abrasive grain and resin around a center core
- Offers a wide range of uses from heavy burr removal to cleaning rust and oxides

SCOTCH-BRITE™ MULTI-FINISHING WHEELS

Produces uniform grain finishes on stainless steel and other metals.

- Highly conformable
- Tough enough to finish edges and welds



Model No.	Grit	Finish	Size"	Max. RPM	Price /Each
BP715	25	Coarse	6 x 1 x 1	6000	87.50
BP717	25	Medium	6 x 1 x 1	6000	87.50
BP718	25	Coarse	6 x 2 x 1	6000	136.32
BP720	25	Medium	6 x 2 x 1	6000	136.32
BP721	25	Coarse	8 x 1 x 3	4500	121.87
BP723	25	Medium	8 x 1 x 3	4500	124.29

SCOTCH-BRITE™ EXL DEBURRING WHEELS

Use to clean, finish, blend, deburr or polish all types of metals, composites and glass.



Model No.	Grit	Finish	Size"	Max. RPM	Price /Each
BP694	8A	Medium	6 x 1/2 x 1	6000	94.49
BP695	8S	Fine	6 x 1/2 x 1	6000	94.50
BP696	9S	Fine	6 x 1/2 x 1	6000	94.50
BP690	8A	Medium	6 x 1 x 1	6000	125.30
BP692	8S	Fine	6 x 1 x 1	6000	125.30
BP693	9S	Fine	6 x 1 x 1	6000	125.30
BP697	8A	Medium	8 x 1 x 3	4500	160.16
BP698	8S	Fine	8 x 1 x 3	4500	160.16
BP700	9S	Fine	8 x 1 x 3	4500	160.16
BP704	8A	Medium	8 x 2 x 3	4500	272.77
BP705	8S	Fine	8 x 2 x 3	4500	272.77
BP706	9S	Fine	8 x 2 x 3	4500	272.77

SCOTCH-BRITE™ EXL UNITIZED DEBURRING WHEELS

Excellent for deburring and polishing a wide range of metals, plastics and composites.

- Cool running allows more pressure to be applied
- Cleaner than buffs and compounds
- Eliminate danger of loose-flying wires



Model No.	Grit	Finish	Size"	Max RPM	Price /Each
BP737	2A	Medium	1 x 1 x 3/16	25 100	6.62
BP738	2S	Fine	1 x 1 x 3/16	30 100	6.62
BP739	6A	Medium	1 x 1 x 3/16	35 100	7.01
BP741	8A	Coarse	1 x 1 x 3/16	35 100	7.98
BP742	8A	Medium	1 x 1 x 3/16	35 100	7.98
BP743	2A	Medium	3 x 1/4 x 3/8	12 100	11.73
BP744	2S	Fine	3 x 1/4 x 3/8	12 100	10.69
BP745	4A	Fine	3 x 1/4 x 3/8	18 100	11.68
BP746	6A	Medium	3 x 1/4 x 3/8	18 100	12.73
BP747	6S	Fine	3 x 1/4 x 3/8	18 100	12.73
BP748	8A	Coarse	3 x 1/4 x 3/8	18 100	14.06
BP749	8A	Medium	3 x 1/4 x 3/8	18 100	14.06

SCOTCH-BRITE™ HIGH STRENGTH DISCS (ALUMINUM OXIDE)

- Very conformable discs
- Ideal for light deburring, cleaning and finishing



Model No.	Dia."	Grade	Max. RPM	Price /Each
NW051	6 x 1/4	Very Fine	4000	4.46
NW052	6 x 1/2	Medium	4000	8.82
NW053	6 x 1/2	Very Fine	4000	4.46
NW054	8 x 1/2	Medium	3000	13.51

SCOTCH-BRITE™ CUT & POLISH WHEELS

Heavy-duty wheels for aggressive blending and finishing.

- Produce uniform results quickly and easily
- Replace rubber bonded wheels, set-up wheels and lap wheels



WHEEL ACCESSORIES

Flange Adaptor No. 5: For use with 6" wheels. Telescoping wheel adaptors 1" and 1/2" wide to reduce 1" wheel cores to fit 5/8". Must be used with side flanges.



Model No.	Size"	Price /Each
NW081	1 x 1 x 1/2	43.50

MANDRELS

Designed for use with Scotch-Brite™ unitized wheels.

Model No.	Size"	Max RPM	Price /Each
BP505	2 1/16 x 1/4 x 3/4	22 200	13.26
NW076	1 3/4 x 1/4 x 1/2	35 200	18.15
BP508	1 3/4 x 1/4	18 200	43.00



ABRASIVES

CURVED HANDLE SCRATCH BRUSHES



BZ606

Model No.	Length of brush"	O.A. Length"	Description	Wire Rows	Trim Length"	Price /Each
BZ970	6	13 11/16	Stainless Steel	3 x 19	1 1/8	9.29
BZ606	6	13 11/16	Steel	3 x 19	1 1/8	4.59
NP248*	6	13 11/16	Steel	3 x 19	1 1/8	7.39
BZ607**	6	13 11/16	Steel	4 x 19	1 1/8	7.09

*With scraper ** Heavy-duty

CURVED-HANDLE SCRATCH BRUSHES

- Durable hardwood handles that have a smooth finish for extra comfort



TC065



Model No.	Brush Width"	Brush Length"	O.A. Length"	Fill Material	Wire Rows	Trim Length"	Price /Each
TC065	15/16	6	14	Steel	3 x 19	1 1/8	6.39
TC068	15/16	6	14	Stainless Steel	3 x 19	1 1/8	12.90
TT167	15/16	6	14	Brass	3 x 19	1 1/8	13.50
TC066	1 1/8	6	14	Steel	4 x 19	1 1/8	7.59
TT170	1 1/8	6	14	Stainless Steel	4 x 19	1 1/8	13.90
TT169	1 1/8	6	14	Brass	4 x 19	1 1/8	15.90

SHOE HANDLE SCRATCH BRUSHES

- Durable hardwood handles that have a smooth finish for extra comfort
- Brush Width: 1 1/16"



TC067



Model No.	Brush Length"	O.A. Length"	Fill Material	Wire Rows	Trim Length"	Price /Each
TC067	5 1/4	10	Steel	5 x 13	1 1/8	6.19
TC074	5 1/4	10	Stainless Steel	5 x 13	1 1/8	14.50
TT168	5 1/4	10	Brass	5 x 13	1 1/8	17.50

SCRATCH BRUSHES WITH SCRAPER

- Durable hardwood handles that have a smooth finish for extra comfort
- Hang-up hole for easy storage



NUS40



Model No.	Brush Width"	Brush Length"	O.A. Length"	Fill Material	Wire Rows	Trim Length"	Price /Each
STRAIGHT HANDLE							
TT171	1 1/2	5 1/2	11 3/8	Steel	5 x 13	1 1/8	17.90
CURVED HANDLE							
NUS40	15/16	5 3/4	13	Steel	3 x 19	1	8.09
NUS42	2	4	20	Stainless Steel	3 x 10	1	39.50

FLAT WIRE BUTCHER BLOCK BRUSHES

- Flat wire butcher block that offers a more aggressive scrub than round wire counterparts
- Durable hardwood block



NUS48



Model No.	Brush Width"	Brush Length"	O.A. Length"	Fill Material	Wire Rows	Trim Length"	Price /Each
NUS46*	4	8 1/2	9	Flat Steel Wire	8 x 12	1 1/8	47.90
NUS48	2 5/8	7	7 5/8	Flat Steel Wire	5 x 10	1	31.50

* Comes with a wood handle

ROUND WIRE BUTCHER BLOCK BRUSHES

- Round wire butcher block that offers a gentler scrub than flat wire counterparts
- Durable hardwood block
- Brush Width: 2 1/2"



Model No.	Brush Length"	O.A. Length"	Fill Material	Wire Rows	Trim Length"	Price /Each
NW102	7	7 1/4	Steel	6 x 19	1 1/8	11.50

INDUSTRIAL-DUTY SCRATCH BRUSHES

- Wood handle
- Choice of carbon or stainless steel bristles



NT607

NT609

NT615



Model No.	Length of Brush"	O.A. Length"	Wire Bristles	Rows	Trim Length"	Price /Each
LONG HANDLE BRUSHES						
NT607	5 3/4	13 3/4	Carbon Steel	3 x 19	1	3.60
NT608	5 3/4	13 3/4	Carbon Steel	4 x 19	1	4.25
NT611	5 3/4	13 3/4	Stainless Steel	3 x 19	1	5.50
NT612	6	10 1/4	Stainless Steel	4 x 19	1	5.95
SHOE HANDLE BRUSHES						
NT609	5 1/4	10 1/2	Carbon Steel	3 x 16	1	3.20
NT610	5 1/4	10 1/2	Carbon Steel	4 x 16	1	3.50
NT613	5	10 1/2	Stainless Steel	3 x 16	1	5.95
NT614	5	10 1/4	Stainless Steel	4 x 16	1	6.40
"TOOTHBRUSH" CLEANING BRUSH						
NT615	1 1/2	7 3/4	Stainless Steel	3 x 7	1/2	1.60

PRO COUNTER DUSTERS

- Sturdy, light-weight brushing tools
- Recommended for dusting and chip removal
- Can be used wet or dry, will not load

OSBORN

JACKSONLEA



BZ986

Model No.	Length of brush"	Description	Trim Length"	Price /Each
BZ986	8	Black Tampico	2 1/2	10.50
NP243	8	Light Blue Polypro	2 1/2	9.79

V-GROOVE LONG HANDLE SCRATCH BRUSHES

- Designed for use in hard-to-reach areas that require a narrow face

OSBORN

JACKSONLEA



BZ985

Model No.	Description	Wire Rows	Trim Length"	Price /Each
BZ985	Stainless Steel	3 x 14	1 1/2	12.90
NP245	Steel	3 x 14	1 1/2	8.09

STRAIGHT HANDLE SCRATCH BRUSHES W/SCRAPER



BZ979

OSBORN

JACKSONLEA

Model No.	Length of brush"	O.A. Length"	Wire Rows	Trim Length"	Price /Each
BZ979	5 1/2	11 3/8	4 x 11	1 5/8	12.50

SMALL CLEANING SCRATCH BRUSHES

- Fill Diameter: 0.006"
- Brush Width: 3/4"

OSBORN

JACKSONLEA



TC070

Model No.	Brush Length"	O.A. Length"	Fill Material	Wire Rows	Trim Length"	Price /Each
WOOD						
TC070	1 1/2	7 3/4	Stainless Steel	3 x 7	1/2	5.19
TC073	1 1/2	7 3/4	Brass	3 x 7	1/2	5.59
NU537	1 1/2	7 3/4	Nylon	3 x 7	1/2	5.19
PLASTIC						
NU538	1 1/2	7 3/4	Stainless Steel	3 x 7	1/2	5.49
NU539	1 1/2	7 3/4	Brass	3 x 7	1/2	4.39
ANGLED BACK						
NP247	1 7/16	7 3/4	Brass	3 x 7	7/16	4.69
NP250	1 7/16	7 3/4	Polypro	3 x 7	7/16	5.29
BZ976	1 7/16	7 3/4	Stainless Steel	3 x 7	7/16	3.09
NP249	1 7/16	7 3/4	Steel	3 x 7	7/16	3.49
CURVED BACK						
NP255	2 1/2	8 5/8	Brass	2 x 9	5/8	4.39
NP256	2 1/2	8 5/8	Stainless	2 x 9	5/8	4.49

V-TRIM SMALL HANDLE SCRATCH BRUSHES



BZ982

OSBORN

JACKSONLEA

Model No.	Description	Length of brush"	O.A. Length"	Wire Rows	Trim Length"	Price /Each
NP246	Steel	1 1/2	7 7/8	3 x 7	1/2	8.19
NP244	Stainless Steel	1 1/2	7 7/8	3 x 7	1/2	9.29
BZ982	Brass	1 1/2	7 7/8	3 x 7	1/2	8.19

MATRIX
INDUSTRIAL PRODUCTS

Maintain the ideal temperature in your workplace

ABRASIVES

ECONOMY BRUSHES

- An economic alternative to the high-value Osborn® brand
- Geared toward light industrial and DIY users
- Selected from the fastest movers in the Osborn® line to provide a complete selection of quick-turning products
- Standard arbor sizes or shanks
- Power brushes with plain arbor holes come packaged with adapters for common drive sizes
- High-speed thread adapters are included in the Osborn® economy line to fit most threaded drives
- All power brushes are display packaged

OSBORN®

JACKSONLEA



CRIMPED WIRE WHEEL BRUSHES - NARROW FACE INCLUDES 1/2" AND 5/8" ADAPTERS

Model No.	Mfg. No.	Brush Dia."	Arbor Hole"	Fill Dia."	Type	Face Width"	Max. RPM	Price /Each
NU096	99009	6	2	0.014	Steel	5/8	6000	15.90
NU097	99010	8	2	0.014	Steel	5/8	4500	23.50



CRIMPED WIRE WHEEL BRUSHES - WIDE FACE INCLUDES 1/2" AND 5/8" ADAPTERS

Model No.	Mfg. No.	Brush Dia."	Arbor Hole"	Fill Dia."	Type	Face Width"	Max. RPM	Price /Each
NU103	99022	6	2	0.014	Steel	1 1/4	6000	30.50
NU104	99023	8	2	0.014	Steel	1 1/2	4500	56.90



CRIMPED WIRE WHEEL BRUSHES - MEDIUM FACE INCLUDES 1/2" AND 5/8" ADAPTERS

Model No.	Mfg. No.	Brush Dia."	Arbor Hole"	Fill Dia."	Type	Face Width"	Max. RPM	Price /Each
NU098	99012	6	2	0.008	Steel	3/4	6000	30.50
NU099	99015	6	2	0.014	Steel	3/4	6000	21.50
NU100	99016	7	2	0.014	Steel	3/4	6000	31.50
NU101	99013	8	2	0.008	Steel	3/4	6000	42.90
NU102	99017	8	2	0.014	Steel	3/4	4500	30.10



HIGH SPEED STRINGER BEAD KNOT WIRE WHEEL BRUSH

Model No.	Mfg. No.	Brush Dia."	Arbor Hole"	Fill Dia."	Type	Face Width"	Max. RPM	Price /Each
NU105	99083	5	5/8-11	0.02	Steel	3/16	12000	21.90
NU106	99089	6	5/8-11	0.02	Stainless	1/4	12000	51.50
NU107	99084	6	5/8-11	0.02	Steel	1/4	12000	17.50
NU108	99086	6 1/2"	5/8-11	0.02	Steel	3/16	12000	17.90



KNOT WIRE END BRUSH

Model No.	Mfg. No.	Brush Dia."	Fill Dia."	Stem Dia."	Type	Max. RPM	Price /Each
NU109	99098	3/4	0.014	1/4	Steel	20000	10.90
NU110	99099	3/4	0.02	1/4	Steel	20000	8.09
NU111	99100	1	0.012	1/4	Steel	20000	12.50
NU112	99101	1	0.014	1/4	Steel	20000	9.19
NU113	99102	1	0.02	1/4	Steel	20000	8.89
NU114	99103	1	0.014	1/4	Stainless	20000	20.90

ATB™ NYLON ABRASIVE COMPOSITE FLEXIBLE WHEEL BRUSHES

- Brushes with long trim and moderate density offer long brush life, less filament breakage and uniform distribution of filaments
- Maximum RPM: 3600
- Ideal for applications requiring a high degree of conformability
- **Applications:** Turbine blades, indexable cutting tool inserts, cam shafts, machined parts, and edge radiusing

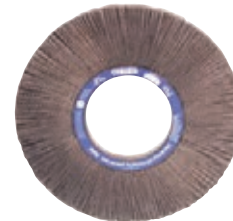

OSBORN®

JACKSONLEA

Model No.	Brush Dia."	Grit	Filament Diameter (mm)	Arbor Hole"	Face Width"	Trim Length"	Price /Each
NT733	6	80	0.04	2	1	1 1/4	86.90
NT735	6	120	0.028	2	1	1 1/4	86.90
NT736	6	120	0.04	2	1	1 1/4	86.90
NT737	6	180	0.035	2	1	1 1/4	90.50
NT738	6	320	0.022	2	1	1 1/4	90.50
NT740	8	80	0.04	1 1/4	1	2 1/4	135.00
NT741	8	120	0.04	1 1/4	1	2 1/4	135.00
NT742	8	180	0.035	1 1/4	1	2 1/4	135.00
NT743	8	320	0.022	1 1/4	1	2 1/4	135.00

END BRUSHES

Especially suited for use on portable air and electric tools, CNC and robotic equipment, the end brush is designed for work where space limitations are a factor. In most applications, higher speeds (up to 25 000 RPM) are required for effective brushing action. Osborn® end brush fill materials include carbon and stainless steels, brass, natural fibre, abrasive nylon, and TY® elastomer encapsulated wire.

OD - OUTSIDE DIAMETER

Standard Osborn® end brushes are made with outside diameters from 3/16" through 3". For larger surfaces or "surround" applications, multiple brushes may be clustered. As a guide, add 1/8" to brush O.D. to get overall O.D.

T - TRIM LENGTH

Shorter brush section provides stiffness and faster cutting. Longer filaments have more flexibility for irregular surfaces.

OAL - OVERALL LENGTH

Distance from end of brush part to end of shank.

S - SHANK DIAMETER

All standard end brushes have 1/4" diameter shank. Miniature end brushes have 1/8" diameter shank.



CRIMPED WIRE END BRUSHES

- Engineered to operate at high speeds
- **Applications:** Rubber and Plastic Mold Cleaning/Cleaning Pipe I.D./Removing Rust, Weld Scale and Spatter/Cleaning Castings/Burr Removal/Rubber Flash Removal/Carbon Removal/Spot Facing/Cleaning and Finishing Recessed Areas



CRIMPED WIRE END BRUSHES

- Ideal for flash, scale, rust, corrosion and paint removal
- Softer impact and more flexible than knotted brushes
- Great tool for polishing, edge blending and surface preparation
- Efficient, light cleaning of small hard-to-reach surface areas



WITH 1/4" SHANK

Model No.	Brush Dia."	O.A. Length"	Wire Gauge"	Trim Length"	Max RPM	Price /Each
STEEL						
BX374	1/2	2 3/4	0.0104	1	25 000	9.39
BX375	1/2	2 3/4	0.02	1	25 000	9.09
BX378	3/4	2 3/4	0.02	1	20 000	13.90
STAINLESS						
BX359	1/2	2 3/4	0.0104	1	25 000	15.90
BX360	1/2	2 3/4	0.014	1	25 000	13.90

Model No.	Brush Dia."	Fill Dia."	Shank Size"	Fill Length"	Max RPM	Price /Each
STEEL						
NU447	1/2	0.005	1/4	1	20 000	17.50
TT316	1/2	0.014	1/4	1	20 000	16.50
NU451	1	0.005	1/4	1	20 000	28.90
TT317	1	0.014	1/4	1	20 000	21.50
STAINLESS						
TC135	3/4	0.014	1/4	1	20 000	18.50
NU452	1	0.005	1/4	1	20 000	45.90

KNOT WIRE END BRUSHES

- Ideal for flash, scale, rust, corrosion and paint removal
- Great tool to reach into holes and hard to reach areas
- More aggressive brushing action than crimped brushes
- Low flexibility knotted wire for high impact brushing



KNOT WIRE END BRUSHES

Rugged brushing tools designed with the finest wire to offer efficient usage for a wide variety of tough cleaning and maintenance applications; can be used on CNC equipment. Available with steel, stainless steel and brass wire. Certain styles are available in clamshell packaging.

- **Applications:** Spot Cleaning or Facing/Removal of Slag, Rust or Scale/Cleaning Pipe I.D./Deburring or Flash Removal/Cleaning of Dies, Moulds and Tooling/Pipeline Cleaning



Model No.	Brush Dia."	Fill Dia."	Shank Size"	Fill Length"	Max RPM	Price /Each
STEEL						
NU456	1/2	0.014	1/4	1	22 000	37.90
NU457	3/4	0.014	1/4	1	22 000	38.90
MLP989	1	0.012	1/4	1	25 000	27.50
TT300	1	0.014	1/4	1	25 000	25.90
TC134	1	0.020	1/4	1	25 000	26.50
STAINLESS						
NU453	1	0.012	1/4	1	25 000	46.90
NU454	1	0.014	1/4	1	25 000	51.50
NU455	1	0.020	1/4	1	25 000	51.50

Model No.	Brush Dia."	O.A. Length"	Wire Gauge"	Trim Length"	Max RPM	Price /Each
STEEL						
BX350	1/2	2 3/4	0.014	1 1/8	22 000	21.50
BX353	3/4	2 3/4	0.014	1 1/8	20 000	20.90
BX357	1	2 3/4	0.014	1	20 000	23.50
STAINLESS						
BX481	1/2	2 3/4	0.014	1 1/8	22 000	20.90
BX484	3/4	2 3/4	0.014	1 1/8	20 000	23.50
BX487	1	2 3/4	0.014	1	20 000	28.90

SCUF-GUARD COATED BRUSHES

- Made with a durable elastomer layer on the cup to help prevent accidental scratches or markings on the work surface during operation
- Stainless steel wire



Model No.	Brush Dia."	Brush Length"	O.A. Length"	Fill Dia."	Trim Length"	Max RPM	Price /Each
BX364	1/2	1 1/8	2 3/4	0.006	1 1/8	22 000	36.90
BX366	1/2	1 1/8	2 3/4	0.014	1 1/8	22 000	30.50
BX367	3/4	1 1/8	2 3/4	0.006	1 1/8	20 000	41.90
BX369	3/4	1 1/8	2 3/4	0.014	1 1/8	20 000	31.50
BX370	1	1	2 3/4	0.006	1 1/8	20 000	51.50
BX372	1	1	2 3/4	0.014	1	20 000	41.50



AH - ARBOR HOLE

Osborn® brushes are made with a variety of standard sizes which can easily be adapted to fit any standard spindle.

OD - OUTSIDE DIAMETER

Standard Osborn® wheel brushes are made with outside diameters from about one inch to almost two feet. Generally, the largest diameter that suits your work space and machine speed will be most efficient.

ID - INSIDE DIAMETER

Assuming a fixed O.D., increasing the I.D. produces a stiffer, less flexible brush.

T - TRIM LENGTH

Shorter trim makes a stiff, fast cutting brush. Longer trim makes a more flexible brush for irregular surfaces.

F - FACE WIDTH

Standard face widths range from extremely narrow to several inches wide. Many styles can be mounted in multiple.

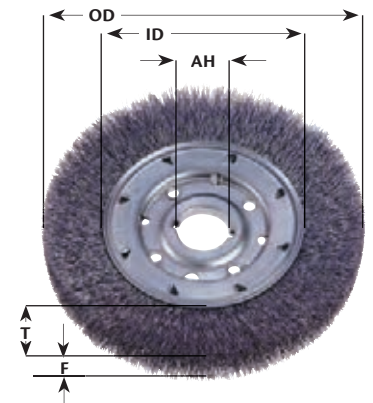

CRIMPED WIRE WHEEL BRUSHES

- Can be mounted horizontally or vertically
- Highly flexible, ideal for light to medium duty surface preparation on irregular surface
- Offered a variety of style from aggressive material removal to surface conditioning and polishing

NARROW FACE

- More flexible than the wide and medium style
- Can be mounted in multiples
- To be used with a straight grinder, a bench/pedestal grinder or a right angle grinder
- **Application:** Deburring and cleaning narrow areas, producing antique finishes, rust and paint removal



Model No.	Brush Dia."	Arbor Hole"	Wire Gauge"	Trim Length"	Face Width"	Max RPM	Price /Each
STEEL							
BW882	6	1 1/4	0.014	1 1/8	5/8	6000	33.90
BW886	8	1 1/4	0.014	1 1/2	5/8	4500	46.90
BW888	10	1 1/4	0.014	2 1/2	5/8	3600	60.90
STAINLESS							
BW899	6	1 1/4	0.014	1 1/8	5/8	6000	68.90
BW900	8	1 1/4	0.014	3/4	1/2	4500	83.50

WIDE FACE

- Maximum wire density and aggression, providing fast, efficient brushing on production work and general maintenance job
- To be used with a bench/pedestal grinder
- **Application:** Deburring, rust removal, surface finishing and cleaning



Model No.	Brush Dia."	Arbor Hole"	Wire Gauge"	Trim Length"	Face Width"	Max RPM	Price /Each
STEEL							
BW968	6	2	0.0118	1	1 1/4	6000	109.00
BW980	8	2	0.0118	1 1/2	1 1/2	4500	145.00
BW983	10	2	0.0118	2 1/8	2	3600	265.00

CRIMPED WIRE WHEEL BRUSH WITH 1/4" SHANK

- Uniform dense fill
- Can be used of hand or on a drill press for internal and external cleaning and deburring
- **Application:** Rust, scale, paint, dirt and weld spatter removal



Model No.	Brush Dia."	Shank Dia."	Wire Gauge"	Trim Length"	Max RPM	Price /Each
STEEL						
BW737	1 1/2	1/4	0.008	0.281	25 000	14.50
BW743	2	1/4	0.014	0.438	25 000	16.50
BW753	3	1/4	0.014	0.75	25 000	16.50
STAINLESS						
BW741	1 1/2	1/4	0.012	0.281	25 000	18.90
BW746	2	1/4	0.014	0.438	25 000	26.50
BW756	3	1/4	0.014	0.75	25 000	31.90



MEDIUM FACE

- Greater fill density and more aggressive brushing action
- Can be adaptable to multiple mounting for brushing wider areas
- To be used with a bench/pedestal grinder
- **Application:** Edge blending, deburring, rust removal, surface finishing and cleaning



Model No.	Brush Dia."	Arbor Hole"	Wire Gauge"	Trim Length"	Face Width"	Max RPM	Price /Each
STEEL							
BW996	6	2	0.0118	1	7/8	6000	54.90
BX006	8	2	0.0118	1 1/2	5/8	4500	77.90
BX022	10	2	0.0118	2	1 1/4	3600	129.00
STAINLESS							
BX038	8	2	0.0118	1 1/2	5/8	4500	129.00

CENTERING BUSHINGS

- Use only one
- For use with Osborn® brushes only



Model No.	Fits AH"	Reduces to"	Price /Each
BY231	1/2	1/4	0.75
BY232	1/2	3/8	0.75
BY234	5/8	3/8	0.75
BY233	5/8	1/2	0.75

SMALL DIAMETER CRIMPED WIRE WHEEL BRUSH

- Specially designed for effective brushing operations on internal surfaces and other hard to reach areas
- Can be mounted singly or in multiples, directly onto the shaft of a portable tool
- To be used with: straight grinder, right angle air die grinder, die grinder, drill.
- **Applications:** Deburring, ID cleaning, rust, scale, carbon and corrosion removal



Model No.	Brush Dia."	Arbor Hole"	Wire Gauge"	Trim Length"	Face Width"	Max RPM	Price /Each
STEEL							
BB458	1 1/2	3/8	0.014	3/8	7/32	20 000	7.99
BB470	2	1/2	0.014	1/2	1/4	20 000	9.89
BW680	3	1/2	0.014	1	1/4	20 000	12.50
STAINLESS							
BB440	2	1/2	0.014	1/2	1/4	20 000	13.50
BW700	3	1/2	0.014	1	1/4	20 000	19.50

KNOT WIRE WHEEL BRUSHES

- The individual knot wire tufts of a knot wheel provide minimal flexibility for more aggressive brushing action
- Rugged knot-type construction provides high brush flexibility, more uniform results, maximum safety and efficient operation at high speeds
- Brushes larger than 6" should be mounted on stationary tables; those 6" and smaller can be mounted to stationary installations or attached to portable tools

STANDARD TWIST KNOT

- Aggressive, high impact action for severe application,
- To be used with straight grinders, bench and pedestal grinder or right angle grinder



STRINGER BEAD

- Tighter knot, fit into more recessed area
- To be used with straight grinders or right angle grinder



There are other wheel sizes, wire sizes & arbor sizes available for all brush types.

Different materials are also available.

STRINGER BEAD

- Small width allows this brush to be used in recessed area such as welding junctions
- **Application:** Cleaning stringer bead welds



OSBORN
JACKSONLEA

Model No.	Brush Dia."	Arbor Hole	Wire Gauge"	Trim Length"	Face Width"	Max RPM	Price /Each
STEEL							
BX338	4 7/8	5/8"-11NC	0.02	1	3/16	12 000	27.90
BX161	6 1/2	5/8"-11NC	0.02	1 1/4	3/16	12 000	45.50
STAINLESS							
BX270	4 7/8	5/8"-11NC	0.02	1	3/16	12 000	51.50
BX273	6 1/2	5/8"-11NC	0.02	1 1/4	3/16	12 000	70.50

HIGH SPEED STEEL SMALL GRINDER, STRINGER BEAD

- Works aggressively, smoothly and efficiently on air or portable power tools
- **Application:** Bead scale removal

OSBORN
JACKSONLEA



Model No.	Brush Dia."	Arbor Hole	Colour	Wire Gauge"	Trim Length"	Max RPM	Price /Each
STEEL							
BX288	4	5/8"-11NC	Steel	0.02	7/8	20 000	26.90
STAINLESS STEEL							
BX311	4	5/8"-11NC	Steel	0.02	7/8	20 000	42.90

STANDARD TWIST KNOT WITH 1/4" SHANK

- Designed to operate at high speeds
- **Applications:** Maintenance and metal surface cleaning

OSBORN
JACKSONLEA



Model No.	Brush Dia."	Wire Gauge"	Trim Length"	Max RPM	Price /Each
STEEL					
BX193	3	0.014	5/8	25 000	32.90
BX196	4	0.014	7/8	20 000	34.50
STAINLESS					
BX195	3	0.014	5/8	25 000	56.90
BX198	4	0.014	7/8	20 000	59.50

STANDARD TWIST KNOT

- **Application:** Removal of rubber flash, paint slag, scale, rust, surface contamination, weld cleaning, blending, finishing, deburring, descaling, pipeline cleaning and general cleaning

OSBORN
JACKSONLEA



Model No.	Brush Dia."	Arbor Hole	Wire Gauge"	Trim Length"	Face Width"	Max RPM	Price /Each
STEEL							
BX125	4	3/8"	0.014	7/8	5/16	20 000	40.50
BX137	6	5/8"-11NC	0.025	1 1/2	1/2	9 000	38.50
BX144	8	5/8"	0.025	1 11/16	5/8	8 500	75.90
STAINLESS							
BX202	4	3/8"	0.014	7/8	5/16	20 000	59.50
BX272	6	5/8"-11NC	0.025	1 1/2	1/2	9 000	69.50

STANDARD TWIST KNOT HIGH SPEED STEEL SMALL GRINDER

- Works aggressively, smoothly and efficiently on air or portable power tools
- **Applications:** Cleans grooves, T-connections, weld beads and surface prep



OSBORN
JACKSONLEA

Model No.	Brush Dia."	Arbor Hole	Colour	Wire Gauge"	Trim Length"	Max RPM	Price /Each
STEEL							
BX305	4	5/8"-11NC	Steel	0.02	7/8	20 000	31.90
BX206	5	5/8"-11NC	Steel	0.02	1	12 000	36.90
STAINLESS							
BX299	4	5/8"-11NC	Steel	0.02	7/8	20 000	54.90
BX207	5	5/8"-11NC	Steel	0.02	1	12 000	90.90

WIRE WHEEL BRUSHES

- Narrow face for confined and hard to reach contact areas
- Low flex high impact aggressive brush action
- Perfect for expansion joints and filler welds
- For root and hot pass weld cleaning
- Customization available



FELTON BRUSHES



Model No.	Brush Dia."	Face Width"	Fill Dia."	Arbor Size	Knot Type	No. of Knots	RPM	Price /Each
STEEL								
TT265	4	3/16	0.020	5/8"-11	Stringer	32	20 000	31.90
TT271	4-7/8	3/16	0.020	5/8"-11	Stringer	48	12 500	41.90
TC019	5-7/8	3/16	0.020	5/8"-11	Stringer	48	12 500	56.90
NU438	4	1/2	0.020	5/8"-11	Standard	20	20 000	36.90
NU440	6	1/2	0.014	5/8"-11	Standard	28	9 000	62.50
NU442	8	5/8	0.014	5/8"-11	Standard	40	6 000	77.50
STAINLESS								
TT270	4	3/16	0.020	5/8"-11	Stringer	32	20 000	44.50
TT272	4-7/8	3/16	0.020	5/8"-11	Stringer	48	12 500	59.90
TT273	5-7/8	3/16	0.020	5/8"-11	Stringer	48	12 500	75.90
NU439	4	1/2	0.020	5/8"-11	Standard	20	20 000	45.76
NU441	6	1/2	0.014	5/8"-11	Standard	28	9 000	60.37
NU443	8	5/8	0.014	5/8"-11	Standard	40	6 000	78.82

ABRASIVES



KNOTTED WIRE WHEEL SAUCER BRUSHES

- More aggressive brushing action than crimped brushes
- Ideal for burr, weld scale, corrosion and paint removal
- Reaches into corners and inside edges for a more effective clean



Model No.	Brush Dia."	Face Width"	Fill Dia."	Arbor Size"	RPM	Price /Each
STEEL						
NU470	4	1/2	0.020	5/8-11	20 000	34.50
NU472	5	7/8	0.020	5/8-11	15 000	40.90
STAINLESS						
NU471	S4	1/2	0.020	5/8-11	20 000	75.50
NU473	S5	7/8	0.020	5/8-11	15 000	85.90

AH - ARBOR HOLE

Most cup brushes are available with either plain or 5/8-11NC threaded arbor holes, while a few styles feature a hexagonal opening, and smaller sizes are fitted with a 1/4" shank.

OD - OUTSIDE DIAMETER

Standard Osborn® cup brushes are made in a range of outside diameters from 2" to 9". Generally, the largest diameter that suits your work space and machine speed will be most efficient.

T - TRIM LENGTH

The length of the fill material that extends beyond the metal cup or bridle. A short trim length provides a stiff, fast-cutting brush, while a longer trim length offers flexibility for dressing irregular surfaces.

R - ROW COUNT & ALIGNMENT

Cup brushes are available with one, two, or three rows of filaments or knots. Unless otherwise identified as "Stagger Row," multiple rows are parallel. Stagger row brushes provide more aggressive action.



CRIMPED WIRE CUP BRUSHES

Designed for light and medium-duty applications on a variety of high speed air and electric tools. Offers smooth, responsive cutting action at all speeds on a variety of jobs.

WITH 1/4" SHANK - LIGHT DUTY

- Offers light duty cleaning action on air tools or electric high-speed portable tools
- All brushes have a 1/4" shank



HIGH SPEED SMALL GRINDER

- Flat brushing
- Surface prep
- Medium duty cleaning of flat surfaces and edges
- Removal of burrs
- Cleaning flat or curved surfaces
- Cleaning edges or angles
- Welding cleanup



Model No.	Brush Dia."	Arbor Hole"	Trim Length"	Max RPM	Price /Each
STEEL					
BX593	1 3/4	0.0118	1/2	13000	14.50
BX530	2 1/2	0.0104	5/8	4500	45.50
STAINLESS					
BX595	1 3/4	0.0118	3/4	13000	25.90
BX572	2 1/2	0.0104	5/8	4500	57.50

Model No.	Brush Dia."	Arbor Hole"	Wire Gauge"	Trim Length"	Max RPM	Price /Each
STEEL						
BX547	2 3/4	5/8-11NC	0.014	1	14000	25.50
BX544	2 3/4	M-10 x 1.25	0.014	1	14000	25.90
BX543	2 3/4	M-14 x 2.0	0.014	1	14000	25.90
STAINLESS						
BX574	2 3/4	5/8-11NC	0.014	1	14000	41.50

3" BRIDLED CUP BRUSHES

- Aggressive tools for fast, heavy-duty cleaning and brushing of metal surfaces
- Removes carbon build up, paint, rust, scale and other contaminants
- Knot twisted with safety control bridle, removable bridle keep the knot oriented and extends brush life



CRIMPED WIRE CUP END BRUSHES

- Removes rust, paint and scale in hard-to-reach areas
- Crimped wire for light to medium-duty applications



Model No.	Brush Dia."	Fill Dia."	Shank Size"	Max RPM	Price /Each
STEEL					
NU465	1 3/4	0.012	1/4	25 000	26.29
NU466	2 3/4	0.014	1/4	25 000	17.79



Model No.	Brush Dia."	Arbor Hole"	Wire Gauge"	Trim Length"	Max RPM	Price /Each
STEEL						
NT969	3	5/8-11NC	0.020	5/8	12 000	18.50
STAINLESS						
NT970	3	5/8-11NC	0.020	5/8	12 000	35.90

KNOT WIRE CUP BRUSHES



Osborn® knot wire cup brushes are rugged, efficient tools for fast, heavy-duty cleaning of large metal surfaces. They are specially designed for use on portable tools and are filled with special analysis Osborn® steel wire. Knot type brushes are recommended for extremely rigorous jobs.

- Removal of weld scale, rust, old paint and corrosion
- Cleaning and surface prep of metals



STEEL

Model No.	Brush Dia."	Arbor Hole"	Wire Gauge"	Row Wide	Trim Length"	Max RPM	Price /Each
BX635	4	5/8-11NC	0.02	2	1	6000	57.90
BX622	6	5/8-11NC	0.035	2	1 3/4	6000	149.00

HIGH SPEED SMALL GRINDER

- Use on portable power tools operating at high speeds, or where uniform cleaning is desired
- Designed for high productivity and long life
- Knot style offers aggressive action
- Available in crimped, knotted and heavy-duty knotted styles
- Designed for 4 1/2" and 5" grinders



Model No.	Brush Dia."	Arbor Hole"	Colour	Wire Gauge"	Trim Length"	Max RPM	Price /Each
STEEL							
BX652	2 3/4	1/2-13NC	Black	0.014	7/8	14000	31.50
BX653	2 3/4	5/8-11NC	Steel	0.014	7/8	14000	23.80
BX650	2 3/4	M-10 x 1.25	Gold	0.014	7/8	14000	31.50
BX651	2 3/4	M-10 x 1.5	Silver	0.014	7/8	14000	31.50
STAINLESS							
BX659	2 3/4	5/8-11NC	Steel	0.014	7/8	14000	37.50
BX656	2 3/4	M-10 x 1.25	Gold	0.014	7/8	14000	49.50

TWISTED TUBE BRUSHES

- For cleaning out small tubes, drill holes or any other small spaces



Model No.	Brush Dia."	Brush Length"	O.A. Length"	Fill Dia."	Price /Each
STEEL					
NU511	1/4	1 1/2	7	0.003	10.50
NU512	3/8	2	8	0.005	10.90
NU513	1/2	2	8	0.005	10.90
NU514	3/4	2 1/2	9	0.005	11.90
NU515	1	3	10	0.008	12.90
STAINLESS					
NU516	1/4	1 1/2	7	0.003	13.90
NU517	3/8	2	8	0.005	14.50
NU519	3/4	2 1/2	9	0.005	15.50
NU520	1	3	10	0.008	16.50
BRASS					
NU689	1/4	1 1/2	7	0.003	9.79
NU522	3/8	2	8	0.005	10.90
NU523	1/2	2	8	0.005	10.90
NU525	1	3	10	0.008	12.90
NYLON					
NU526	1/4	4 1/2	12	0.010	11.50
NU527	3/8	4 1/2	12	0.014	15.50
NU528	1/2	4 1/2	12	0.014	9.89
HAIR					
NU533	1/2	3 1/4	12	0.003	11.50

FLUE BRUSHES

- Mainly used for pipe, boiler tube and flue cleaning
- Filled with round carbon steel wires
- Comes with a 1/4" NPT fitting



Model No.	Brush Dia."	Brush Length"	O.A. Length"	Flue Dia."	Fill Dia."	Price /Each
NU496	1/2	4	7 1/2	3/4	0.012	23.50
NU497	5/8	4	7 1/2	7/8	0.012	24.50
NU498	3/4	4	7 1/2	1	0.012	24.90
NU499	7/8	4	7 1/2	1 1/8	0.012	25.50
NU500	1	4	7 1/2	1 1/4	0.012	25.50
NU501	1 1/4	4	7 1/2	1 1/2	0.012	27.50
NU503	1 3/4	4	7 1/2	2 1/4	0.012	25.50
NU393	2	4	7 1/2	2 1/4	0.012	26.90
NU504	2 1/4	4	7 1/2	2 1/2	0.012	23.90
NU506	2 3/4	4	7 1/2	3	0.012	27.50
NU507	3	4	7 1/2	3 1/4	0.012	27.90
NU508	3 1/4	4	7 1/2	3 1/2	0.012	28.50
NU509	3 1/2	4	7 1/2	3 3/4	0.012	28.90
NU510	3 3/4	4	7 1/2	4	0.012	30.50

KNOTTED WIRE WHEEL CUP BRUSHES

- Strong and effective for heavy duty cleaning
- Top-quality USA steel
- Removes weld scale, rust, old paint and corrosion
- Designed for the most rugged jobs



Model No.	Brush Dia."	Fill Length"	Fill Dia."	Arbor Size"	Flared Dia.	RPM	Price /Each
STEEL							
NU445	2 3/4	1	0.020	5/8-11	3	14000	49.90
TT306	3 1/2	1	0.020	5/8-11	3 3/4	12500	80.50
TT287	4	1 1/4	0.020	5/8-11	4 1/4	9000	75.50
NU446	5	1 3/8	0.020	5/8-11	5 1/4	7000	98.50

CUTTING TOOLS

SOLID CARBIDE BURRS - 1/4" SHANK

SC90 DOUBLE CUT

- 1/4" shank
- Double cut
- Ideal for extra tough materials
- Excellent control allows for clean finish



OVAL SHAPE

Model No.	Mfg. No.	No.	Head Dia."	Flute Length"	Price /Each
TBM290	SC90064	SE-11	3/16	5/16	20.50
BL301	SC90065	SE-1	1/4	3/8	20.50
BL302	SC90066	SE-3	3/8	5/8	24.50
BL303	SC90067	SE-5	1/2	7/8	35.90
BL304	SC90068	SE-6	5/8	1	49.90
BL305	SC90069	SE-7	3/4	1	67.50



TREE SHAPE - WITH RADIUS END

Model No.	Mfg. No.	No.	Head Dia."	Flute Length"	Price /Each
BL306	SC90070	SF-11	1/8	1/2	18.90
BL307	SC90071	SF-1	1/4	5/8	18.90
BL308	SC90072	SF-3	3/8	3/4	24.50
BL309	SC90073	SF-4	7/16	1	33.50
BL310	SC90074	SF-5	1/2	1	35.90
BL311	SC90075	SF-13	1/2	3/4	35.90
BL312	SC90076	SF-6	5/8	1	49.50
BL313	SC90077	SF-7	3/4	1	64.90
BL314	SC90078	SF-14	3/4	1 1/4	81.50
BL315	SC90079	SF-15	3/4	1 1/2	95.50



TREE SHAPE - POINTED END

Model No.	Mfg. No.	No.	Head Dia."	Flute Length"	Price /Each
BL316	SC90080	SG-1	1/4	5/8	18.90
BL317	SC90081	SG-2	5/16	3/4	23.50
BL318	SC90082	SG-3	3/8	3/4	25.90
BL319	SC90083	SG-5	1/2	1	34.90
BL320	SC90084	SG-13	1/2	3/4	34.90
BL321	SC90085	SG-6	5/8	1	48.90
BL322	SC90086	SG-7	3/4	1	64.90
TBM291	SC90087	SG-15	3/4	1 1/2	95.50



FLAME SHAPE

Model No.	Mfg. No.	No.	Head Dia."	Flute Length"	Price /Each
BL323	SC90088	SH-1	1/4	5/8	22.50
BL324	SC90089	SH-2	5/16	3/4	25.50
BL325	SC90090	SH-5	1/2	1 1/4	51.50
BL326	SC90091	SH-6	5/8	1 7/16	71.50
BL327	SC90092	SH-7	3/4	1 5/8	90.50



60° CONE SHAPE

Model No.	Mfg. No.	No.	Head Dia."	Flute Length"	Price /Each
BL328	SC90093	SI-1	1/4	3/16	16.90
BL329	SC90094	SI-3	3/8	5/16	21.90
BL330	SC90095	SI-5	1/2	7/16	26.90
BL331	SC90096	SI-6	5/8	9/16	35.90
BL332	SC90097	SI-7	3/4	11/16	46.90
BL333	SC90098	SI-9	1	15/16	86.50



90° CONE SHAPE

Model No.	Mfg. No.	No.	Head Dia."	Flute Length"	Price /Each
BL334	SC90099	SK-1	1/4	1/8	16.90
BL335	SC90100	SK-3	3/8	3/16	21.90
BL336	SC90101	SK-5	1/2	1/4	26.90
BL337	SC90102	SK-6	5/8	5/16	35.90
BL338	SC90103	SK-7	3/4	3/8	46.90
BL339	SC90104	SK-9	1	1/2	74.90

SOLID CARBIDE BURRS - 1/4" SHANK

SC90 DOUBLE CUT



TAPER - RADIUS END - 14°

Model No.	Mfg. No.	No.	Head Dia."	Flute Length"	Price /Each
BL340	SC90105	SL-1	1/4	5/8	19.90
BL341	SC90106	SL-2	5/16	7/8	25.90
TBM292	SC90107	SL-3	3/8	1 1/16	30.90
BL342	SC90108	SL-4	1/2	1 1/8	37.50
BL343	SC90109	SL-5	5/8	1 3/16	67.50
BL344	SC90110	SL-6	5/8	1 5/16	73.90
BL345	SC90111	SL-7	3/4	1 1/2	97.50

CONE SHAPE



Model No.	Mfg. No.	No.	Head Dia."	Flute Length"	Price /Each
BL346	SC90112	SM-1	1/4	1/2	18.50
BL347	SC90113	SM-2	1/4	3/4	19.90
BL348	SC90114	SM-3	1/4	1	20.90
BL349	SC90115	SM-4	3/8	5/8	30.90
BL350	SC90116	SM-5	1/2	7/8	38.90
BL351	SC90117	SM-6	5/8	1	51.50



INVERTED CONE SHAPE

Model No.	Mfg. No.	No.	Head Dia."	Flute Length"	Price /Each
BL352	SC90118	SN-1	1/4	5/16	16.90
BL353	SC90119	SN-2	3/8	3/8	21.90
BL354	SC90120	SN-4	1/2	1/2	26.90
BL355	SC90121	SN-6	5/8	3/4	37.90
BL356	SC90122	SN-7	3/4	5/8	55.90

CLARKSON OSBORN

8 PIECE SOLID CARBIDE BURR SET - 1/4" SHANK

Model No.
BL445
Mfg. No.
SC90801
Price/Each
\$349.00



KIT CONTAINS:

No.	Head Dia."	Flute Length"
SA-5	1/2	1
SC-3	3/8	3/4
SC-5	1/2	1
SD-5	1/2	7/16
SE-3	3/8	3/4
SF-5	1/2	1
SG-3	3/8	3/4
SL-4	1/2	1 1/8

SOLID CARBIDE BURRS - 1/4" SHANK

SC90 DOUBLE CUT

- 1/4" shank
- Double cut
- Ideal for extra tough materials
- Excellent control allows for clean finish



CYLINDER SHAPE

Model No.	Mfg. No.	No.	Head Dia."	Flute Length"	Price /Each
BL240	SC90002	SA-12	1/8	5/8	15.90
BL241	SC90003	SA-13	5/32	5/8	15.90
BL242	SC90004	SA-14	3/16	5/8	15.90
BL243	SC90005	SA-1	1/4	5/8	15.90
BL244	SC90006	SA-1L	1/4	1	22.90
BL245	SC90007	SA-2	5/16	3/4	20.50
BL246	SC90008	SA-3	3/8	3/4	22.50
BL247	SC90009	SA-3L	3/8	1	26.50
BL248	SC90010	SA-3X	3/8	1 1/2	29.50
BL249	SC90011	SA-4	7/16	1	31.90
BL250	SC90012	SA-5	1/2	1	34.50
BL251	SC90013	SA-6	5/8	1	43.50
BL252	SC90014	SA-7	3/4	1	64.90
BL253	SC90015	SA-15	3/4	1/2	58.90
BL254	SC90016	SA-16	3/4	3/4	64.90
BL255	SC90017	SA-8	7/8	1	81.50
BL256	SC90018	SA-9	1	1	90.50

CYLINDER SHAPE WITH END CUT



Model No.	Mfg. No.	No.	Head Dia."	Flute Length"	Price /Each
BL258	SC90020	SB-12	1/8	5/8	17.50
BL259	SC90021	SB-13	5/32	5/8	17.50
BL260	SC90022	SB-14	3/16	5/8	17.50
BL261	SC90023	SB-1	1/4	5/8	17.50
BL262	SC90024	SB-1L	1/4	1	25.50
BL263	SC90025	SB-2	5/16	3/4	22.90
BL264	SC90026	SB-3	3/8	3/4	24.50
BL265	SC90027	SB-3L	3/8	1	28.90
BL266	SC90028	SB-3X	3/8	1 1/2	30.50
BL267	SC90029	SB-4	7/16	1	35.50
BL268	SC90030	SB-5	1/2	1	37.90
BL269	SC90031	SB-6	5/8	1	47.90
BL270	SC90032	SB-7	3/4	1	71.50
BL271	SC90033	SB-15	3/4	1/2	64.90
BL272	SC90034	SB-16	3/4	3/4	71.50
BL273	SC90035	SB-8	7/8	1	94.90
BL274	SC90036	SB-9	1	1	99.50

SOLID CARBIDE BURRS - 1/4" X 6" LONG SHANK

SC90 DOUBLE CUT

- 6" overall length
- 1/4" shank
- Double cut
- Ideal for extra tough materials
- Excellent control allows for clean finish



CYLINDER SHAPE

Model No.	Mfg. No.	No.	Head Dia."	Flute Length"	Price/Each
BL422	SC90601	SA-1L6	1/4	1/2	21.50
BL423	SC90602	SA-3L6	3/8	3/4	27.90
BL424	SC90603	SA-5L6	1/2	1	36.90



CYLINDER SHAPE WITH RADIUS END

Model No.	Mfg. No.	No.	Head Dia."	Flute Length"	Price/Each
BL425	SC90604	SC-1L6	1/4	1/2	25.90
BL426	SC90605	SC-3L6	3/8	3/4	34.50
BL427	SC90606	SC-5L6	1/2	1	53.90



BALL SHAPE

Model No.	Mfg. No.	No.	Head Dia."	Flute Length"	Price/Each
BL428	SC90607	SD-1L6	1/4	3/16	23.90
BL429	SC90608	SD-3L6	3/8	5/16	28.50
BL430	SC90609	SD-5L6	1/2	7/16	38.50



OVAL SHAPE

Model No.	Mfg. No.	No.	Head Dia."	Flute Length"	Price/Each
BL431	SC90610	SE-1L6	1/4	3/8	28.50
BL432	SC90611	SE-3L6	3/8	5/8	34.50
BL433	SC90612	SE-5L6	1/2	7/8	50.50

CYLINDER SHAPE WITH RADIUS END

Model No.	Mfg. No.	No.	Head Dia."	Flute Length"	Price /Each
BL275	SC90037	SC-11	1/8	1/2	18.50
BL276	SC90038	SC-12	1/8	5/8	18.50
BL277	SC90039	SC-3	5/32	5/8	18.50
BL278	SC90040	SC-14	3/16	5/8	18.50
BL279	SC90041	SC-1	1/4	5/8	18.50
BL280	SC90042	SC-1L	1/4	1	24.90
BL281	SC90043	SC-2	5/16	3/4	22.50
BL282	SC90044	SC-3	3/8	3/4	24.50
BL283	SC90045	SC-3L	3/8	1	28.90
BL284	SC90046	SC-3X	3/8	1 1/2	31.90
BL285	SC90047	SC-4	7/16	1	35.50
BL286	SC90048	SC-5	1/2	1	38.90
BL287	SC90049	SC-6	5/8	1	48.90
BL288	SC90050	SC-7	3/4	1	69.90
TBM293	SC90051	SC-15	3/4	1/2	63.50
BL289	SC90052	SC-16	3/4	3/4	69.90
BL290	SC90053	SC-9	1	1	109.00

CLARKSON OSBORN



BALL SHAPE

Model No.	Mfg. No.	No.	Head Dia."	Flute Length"	Price /Each
BL291	SC90054	SD-11	1/8	3/32	16.90
BL292	SC90055	SD-14	3/16	1/8	16.90
BL293	SC90056	SD-1	1/4	3/16	16.90
BL294	SC90057	SD-2	5/16	1/4	18.50
BL295	SC90058	SD-3	3/8	5/16	20.50
BL296	SC90059	SD-4	7/16	3/8	17.50
BL297	SC90060	SD-5	1/2	7/16	27.50
BL298	SC90061	SD-6	5/8	9/16	33.90
BL299	SC90062	SD-7	3/4	11/16	46.90
BL300	SC90063	SD-9	1	15/16	79.90

CLARKSON OSBORN



TREE SHAPE - RADIUS END

Model No.	Mfg. No.	No.	Head Dia."	Flute Length"	Price/Each
BL434	SC90613	SF-1L6	1/4	1/2	26.90
BL435	SC90614	SF-3L6	3/8	3/4	33.90
BL436	SC90615	SF-5L6	1/2	1	49.90



TREE SHAPE - POINTED END

Model No.	Mfg. No.	No.	Head Dia."	Flute Length"	Price/Each
BL437	SC90616	SG-1L6	1/4	1/2	26.90
BL438	SC90617	SG-3L6	3/8	3/4	35.90
BL439	SC90618	SG-5L6	1/2	1	48.90



FLAME SHAPE

Model No.	Mfg. No.	No.	Head Dia."	Flute Length"	Price/Each
BL440	SC90619	SH-2L6	5/16	3/4	35.50
BL441	SC90620	SH-5L6	1/2	1 1/4	71.90



14° DEGREE TAPER - RADIUS END

Model No.	Mfg. No.	No.	Head Dia."	Flute Length"	Price/Each
BL442	SC90621	SL-1L6	1/4	5/8	27.50
BL443	SC90622	SL-3L6	3/8	1 1/16	42.90
BL444	SC90623	SL-4L6	1/2	1 1/8	52.50

CUTTING TOOLS

STEP DRILL BIT SET

- Dual-flute design provides greater speed and control means a jam-free performance
- Rapid Strike™ Tip creates fast, accurate starts and generates less heat
- **Includes:**
 - #4 Step drill bit (3/16" - 7/8" by 1/16")
 - #2 Step drill bit (3/16" - 1/2" by 1/16")
 - #1 Step drill bit (1/8" - 1/2" by 1/32")



Model No.	Mfg. No.	No. of Pieces	Material	Price /Each
TYE901	48-89-9221	3	High Speed Steel	185.00

STEP DRILL BIT SET

- Dual-flute design provides greater speed and control means a jam-free performance
- Rapid Strike™ Tip creates fast, accurate starts and generates less heat
- **Includes:**
 - (1) #7 Step drill bit (7/8" single hole)
 - (1) #4 Step drill bit (3/16" - 7/8" by 1/16")
 - (1) #12 Step drill bit (7/8" - 1-3/8")
 - (1) #1 Step drill bit (1/8" - 1/2" by 1/32")
 - (1) Carrying case



Model No.	Mfg. No.	No. of Pieces	Material	Price /Each
TYE903	48-89-9223	4	High Speed Steel	255.00

STEP DRILL BIT SET

- Dual-flute design provides greater speed and control means a jam-free performance
- Rapid Strike™ Tip creates fast, accurate starts and generates less heat
- **Includes:**
 - (1) #9 Step drill bit (7/8" & 1-1/8"),
 - (1) #8 Step drill bit (1/2" - 1" by 1/16")
 - (1) #7 Step drill bit (7/8" single hole)
 - (1) #6 Step drill bit (3/8" - 1/2" by 1/16")
 - (1) #4 Step drill bit (3/16" - 7/8" by 1/16")
 - (1) #1 Step drill bit (1/8" - 1/2" by 1/32")
 - (1) Carrying case



Model No.	Mfg. No.	No. of Pieces	Material	Price /Each
TYE904	48-89-9224	6	High Speed Steel	465.00

SHOCKWAVE™ IMPACT DUTY™ STEP DRILL BIT SET

- **Includes:**
 - #1 Shockwave™ Impact Duty™ drill bit,
 - #2 Shockwave™ Impact Duty™ drill bit,
 - #4 Shockwave™ Impact Duty™ drill bit



Model No.	Mfg. No.	No. of Pieces	Material	Price /Each
TCR722	48-89-9254	3	Titanium	215.00

COMBINED DRILLS & COUNTERSINKS

- Solid carbide 10% cobalt
- Right-hand cut
- Each drill has 2 hole diameters
- 118° angle point
- 60° countersink angle
- Bright finish

CLARKSON  OSBORN



Applications:
Designed to produce accurate centre holes in components which require machining between centres.

Model No.	Size No.	Small Dia.™	Large Dia.™	Overall Length™	Price /Each
BK813	00	1/32	1/8	1 1/2	23.50
BK820	0	0.025	1/8	1 1/2	25.90
BK814	1	3/64	1/8	1 1/2	21.90
BK815	2	5/64	3/16	1 7/8	33.90
BK816	3	7/64	1/4	2	38.50
BK817	4	1/8	5/16	2 1/8	52.50
BK818	5	3/16	7/16	2 3/4	98.90
BK819	6	7/32	1/2	3"	115.00

MULTI-STEP DRILL BIT SET

 **WALTER**
Surface Technologies

- Special AlCrN coating provides additional toughness and wear-resistance to prolong tooling life
- 2 wide, cylindrical flutes eliminate chip build-up for faster drilling and produce holes with minimum vibration or distortion
- Each shank has three flats for easy mounting
- Perfect for cutting or enlarging holes in sheet material
- Special bronze SST heat and surface treatment
- **Includes:**
 - (1) 13 step from 1/8" to 1/2"
 - (1) 12 step from 3/16" to 7/8"
 - (1) 10 step from 1/4" to 1-3/8"



Model No.	Mfg. No.	No. of Pieces	Material	Price /Each
TC0443	01W951	3	High Speed Steel	335.00

STEP DRILLS

- High speed steel
- Bright finish

CLARKSON  OSBORN

Applications:
Stepped cone design provides better control of hole sizes in materials up to 1/8" thick. One step drill does job of up to 13 different size drills. Holes are automatically deburred by cutting edge of next larger size. Ideal for sheet metal and hole-enlarging work.

TJZ800



Model No.	Description	Price/Each
TJZ800	Step drill 3-piece set – contains #1, #2 and #3 step drills in plastic case	105.00

Model No.	Size No.	# of holes	Range from - to	Increments	Price /Each
TJZ795	1	13	1/8 to 1/2	1/32	27.90
TJZ796	2	6	3/16 to 1/2	1/16	25.90
TJZ797	3	9	1/4 to 3/4	1/16	46.50
TJZ798	4	12	3/16 to 7/8	1/16	31.90
TJZ799	5	10	1/4 to 1 3/8	1/8	63.90

STEP DRILL BIT

- Flute Type: Straight



TYE890



TYE900



Model No.	Mfg. No.	Description	Shank Size™	Min. Drill Size™	Max. Drill Size™	Price /Each
TYE890	48-89-9201	#1	1/4	1/8	1/2	46.50
TYE893	48-89-9204	#4	3/8	7/8	3/16	72.50
TYE894	48-89-9205	#5	3/8	1/4	1-3/8	105.00
TYE898	48-89-9209	#9	3/8	7/8	1-1/8	84.50
TYE900	48-89-9212	#12	3/8	7/8	1-3/8	98.50

JOBBER LENGTH – HIGH SPEED STEEL

BLACK & GOLD

- Industrial-duty
- Straight shank, 2-flute design
- Right hand cutting direction
- 135° split point, self-centering eliminates walking
- Two-tone treatment increases resistance to abrasion and chip flow

Applications:

General purpose and heavy drilling operations. Ideal for ferrous metals: steel, cast iron, ferrous metals and alloys, non-metallic material.

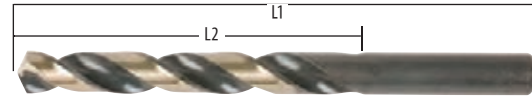

Model No.	Fractional Size"	Decimal Size"	L2"	L1"	Price /Each
QD657	1/64	0.0156	3/16	13/16	3.29
QD658	1/32	0.0312	13/32	13/16	2.09
QD659	3/64	0.0469	7/8	1 7/8	1.99
QD660	1/16	0.0625	7/8	1 7/8	1.99
QD661	5/64	0.0781	1	2	1.99
QD662	3/32	0.0938	1 1/4	2 1/4	1.99
QD663	7/64	0.1094	1 1/2	2 5/8	2.19
QD664	1/8	0.1250	1 5/8	2 3/4	2.59
QD665	9/64	0.1406	1 3/4	2 7/8	2.59
QD666	5/32	0.1562	2	3 1/8	2.69
QD667	11/64	0.1719	2 1/8	3 1/4	2.99
QD668	3/16	0.1875	2 5/16	3 1/2	3.29
QD669	13/64	0.2031	2 7/16	3 5/8	3.79
QD670	7/32	0.2188	2 1/2	3 3/4	4.29
QD671	15/64	0.2344	2 5/8	3 7/8	4.49
QD672	1/4	0.2500	2 3/4	4	4.79
QD673	17/64	0.2656	2 7/8	4 1/8	5.79
QD674	9/32	0.2812	2 15/16	4 1/4	5.89
QD675	19/64	0.2969	3 1/16	4 3/8	6.79
QD676	5/16	0.3125	2 3/16	4 1/2	7.49
QD677	21/64	0.3281	3 5/16	4 5/8	8.29
QD678	11/32	0.3438	3 7/16	4 3/4	9.29
QD679	23/64	0.3594	3 1/2	4 7/8	10.50

Model No.	Wire Ga. Size	Decimal Size"	L2"	L1"	Price /Each
BF675	80	0.0135	5/32	3/4	3.89
BF674	79	0.0145	5/32	3/4	3.89
BF673	78	0.0160	3/16	13/16	3.29
BF672	77	0.0180	3/16	13/16	3.29
BF671	76	0.0200	1/4	7/8	3.29
BF670	75	0.0210	9/32	15/16	3.29
BF669	74	0.0225	9/32	15/16	3.29
BF668	73	0.0240	5/16	1	3.29
BF667	72	0.0250	5/16	1	3.29
BF666	71	0.0260	5/16	1	3.29
BF665	70	0.0280	11/32	1 1/8	2.99
BF664	69	0.0292	11/32	1 1/8	2.99
BF663	68	0.0310	13/32	1 3/16	2.49
BF662	67	0.0320	13/32	1 3/16	2.49
BF661	66	0.0330	13/32	1 3/16	2.49
QD721	65	0.0350	7/16	1 1/4	2.49
BF660	64	0.0360	7/16	1 1/4	2.49
BF659	63	0.0370	7/16	1 1/4	2.49
BF658	62	0.0380	15/32	1 5/16	2.49
BF657	61	0.0390	15/32	1 5/16	2.49
BF656	60	0.0400	11/16	1 5/8	2.49
BF655	59	0.0410	11/16	1 5/8	2.49
BF654	58	0.0420	11/16	1 5/8	2.49
BF653	57	0.0430	3/4	1 3/4	2.49
BF652	56	0.0465	3/4	1 3/4	2.39
BF651	55	0.0520	7/8	1 7/8	2.39
BF650	54	0.0550	7/8	1 7/8	2.39
BF649	53	0.0595	7/8	1 7/8	2.29
BF648	52	0.0635	7/8	1 7/8	2.29
QD720	51	0.0670	1	2	2.29
BF647	50	0.0700	1	2	2.29
QD719	49	0.0730	1	2	2.29
BF646	48	0.0760	1	2	2.29
QD718	47	0.0785	1	2	2.29
BF645	46	0.0810	1 1/8	2 1/8	2.29
BF644	45	0.0820	1 1/8	2 1/8	2.29
BF643	44	0.0860	1 1/8	2 1/8	2.29
QD717	43	0.0890	1 1/4	2 1/4	2.29
QD716	42	0.0935	1 1/4	2 1/4	2.29
BF642	41	0.0960	1 3/8	2 3/8	2.39

Model No.	Letter Size	Decimal Size"	L2"	L1"	Price /Each
BF603	A	0.2340	2 5/8	3 7/8	4.89
BF604	B	0.2380	2 3/4	4	5.09
BF605	C	0.2420	2 3/4	4	5.09
BF606	D	0.2460	2 3/4	4	5.09
-	E	0.2500	2 3/4	4	-
BF608	F	0.2570	2 7/8	4 1/8	5.89
BF609	G	0.2610	2 7/8	4 1/8	6.19
BF610	H	0.2660	2 7/8	4 1/8	6.19
BF611	I	0.2720	2 7/8	4 1/8	6.19
BF612	J	0.2770	2 7/8	4 1/8	6.49
BF613	K	0.2810	2 15/16	4 1/4	6.79
BF614	L	0.2900	2 15/16	4 1/4	7.29
BF615	M	0.2950	3 1/16	4 3/8	7.69

Model No.	Fractional Size"	Decimal Size"	L2"	L1"	Price /Each
QD680	3/8	0.3750	3 5/8	5	9.89
QD681	25/64	0.3906	3 3/4	5 1/8	11.90
QD682	13/32	0.4062	3 7/8	5 1/4	12.50
QD683	27/64	0.4219	3 15/16	5 3/8	13.90
QD684	7/16	0.4375	4 1/16	5 1/2	14.50
QD685	29/64	0.4531	4 3/16	5 5/8	16.90
QD686	15/32	0.4688	4 5/16	5 3/4	17.50
QD687	31/64	0.4844	4 3/8	5 7/8	17.90
QD688	1/2	0.5000	4 1/2	6	17.50
BF590	33/64	0.5156	4 13/16	6 5/8	26.90
BF591	17/32	0.5313	4 13/16	6 5/8	25.90
BF592	35/64	0.5469	4 13/16	6 5/8	33.90
BF593	9/16	0.5625	4 13/16	6 5/8	35.90
BF594	37/64	0.5781	4 13/16	6 5/8	38.90
BF595	19/32	0.5938	5 3/16	7 1/8	51.50
BF596	39/64	0.6094	5 3/16	7 1/8	48.50
BF597	5/8	0.6250	5 3/16	7 1/8	48.50
BF598	41/64	0.6406	5 3/16	7 1/8	49.90
BF599	21/32	0.6563	5 3/16	7 1/8	58.50
BF600	43/64	0.6719	5 5/8	7 5/8	59.90
BF601	11/16	0.6875	5 5/8	7 5/8	62.50
BF602	3/4	0.7500	5 1/2	8 1/16	62.50

Model No.	Wire Ga. Size	Decimal Size"	L2"	L1"	Price /Each
BF641	40	0.0980	1 3/8	2 3/8	2.39
QD715	39	0.0995	1 3/8	2 3/8	2.39
BF640	38	0.1015	1 7/16	2 1/2	2.39
BF639	37	0.1040	1 7/16	2 1/2	2.39
QD714	36	0.1065	1 7/16	2 1/2	2.39
QD713	35	0.1100	1 1/2	2 5/8	2.39
BF638	34	0.1110	1 1/2	2 5/8	2.39
BF637	33	0.1130	1 1/2	2 5/8	2.39
QD712	32	0.1160	1 5/8	2 3/4	2.39
QD711	31	0.1200	1 5/8	2 3/4	2.39
QD709	29	0.1360	1 3/4	2 7/8	2.39
BF636	28	0.1405	1 3/4	2 7/8	2.39
BF635	27	0.1440	1 7/8	3	2.59
QD708	26	0.1470	1 7/8	3	2.59
QD707	25	0.1495	1 7/8	3	2.59
QD706	24	0.1520	2	3 1/8	2.79
QD705	23	0.1540	2	3 1/8	2.79
QD704	22	0.1570	2	3 1/8	2.79
QD703	21	0.1590	2 1/8	3 1/4	2.89
QD702	20	0.1610	2 1/8	3 1/4	2.99
BF634	19	0.1660	2 1/8	3 1/4	2.99
QD701	18	0.1695	2 1/8	3 1/4	2.99
BF633	17	0.1730	2 3/16	3 3/8	3.39
QD700	16	0.1770	2 3/16	3 3/8	3.39
QD699	15	0.1800	2 3/16	3 3/8	3.49
QD698	14	0.1820	2 3/16	3 3/8	3.49
QD697	13	0.1850	2 5/16	3 1/2	3.49
QD696	12	0.1890	2 5/16	3 1/2	3.79
QD695	11	0.1910	2 5/16	3 1/2	3.79
QD694	10	0.1935	2 7/16	3 5/8	3.79
BF632	9	0.1960	2 7/16	3 5/8	3.79
BF631	8	0.1990	2 7/16	3 5/8	3.79
QD693	7	0.2010	2 7/16	3 5/8	3.79
BF630	6	0.2040	2 1/2	3 3/4	4.29
BF629	5	0.2055	2 1/2	3 3/4	4.29
QD692	4	0.2090	2 1/2	3 3/4	4.29
QD691	3	0.2130	2 1/2	3 3/4	4.29
BF628	2	0.2210	2 5/8	3 7/8	4.79
BF627	1	0.2280	2 5/8	3 7/8	4.79

Model No.	Letter Size	Decimal Size"	L2"	L1"	Price /Each
QD689	N	0.3020	3 1/16	4 3/8	7.99
BF616	O	0.3160	3 3/16	4 1/2	8.09
BF617	P	0.3230	3 5/16	4 5/8	8.79
BF618	Q	0.3320	3 7/16	4 3/4	9.19
BF619	R	0.3390	3 7/16	4 3/4	9.59
QD690	S	0.3480	3 1/2	4 7/8	10.50
BF620	T	0.3580	3 1/2	4 7/8	10.90
BF621	U	0.3680	3 5/8	5	11.90
BF622	V	0.3770	3 5/8	5	12.50
BF623	W	0.3860	3 3/4	5 1/8	12.90
BF624	X	0.3970	3 3/4	5 1/8	14.50
BF625	Y	0.4040	3 7/8	5 1/4	15.90
BF626	Z	0.4130	3 7/8	5 1/4	16.50

CUTTING TOOLS

JOBBER LENGTH – COBALT

- M42 cobalt provides wear and heat resistance
- Straight shank , 2 flute design
- Right hand cutting direction
- 135° split point, self-centring eliminates walking
- Bright finish

Applications

For general purpose drilling to heavy-duty operations in high tensile strength steel and alloys, stainless steels and other ferrous metals.

CLARKSON OSBORN



Model No.	Fractional Size"	Decimal Size"	L2"	L1"	Price /Each
BG098	1/64	0.0156	3/16	13/16	7.29
BG099	1/32	0.0312	13/32	13/16	5.79
BG100	3/64	0.0469	5/8	1 1/2	4.49
BG101	1/16	0.0625	25/32	1 11/16	4.39
BG102	5/64	0.0781	15/16	1 15/16	5.99
BG103	3/32	0.0938	13/16	2 1/4	3.89
BG104	7/64	0.1094	15/16	2 13/32	3.99
BG105	1/8	0.1250	17/16	2 9/16	4.09
QD740	9/64	0.1406	1 17/32	2 3/4	5.19
BG106	5/32	0.1562	1 11/16	2 15/16	5.19
BG107	11/64	0.1719	1 27/32	3 5/32	6.09
BG108	3/16	0.1875	2 1/16	3 3/8	6.49
BG109	13/64	0.2031	2 1/16	3 3/8	6.89
BG110	7/32	0.2188	2 1/4	3 21/32	7.09
BG111	15/64	0.2344	2 1/4	3 21/32	7.99
BG112	1/4	0.2500	2 1/2	3 31/32	8.79

Model No.	Fractional Size"	Decimal Size"	L2"	L1"	Price /Each
BG113	17/64	0.2656	2 23/32	4 9/32	10.50
BG114	9/32	0.2812	2 23/32	4 9/32	11.50
BG115	19/64	0.2969	2 15/16	4 19/32	12.90
BG116	5/16	0.3125	2 15/16	4 19/32	14.50
BG117	21/64	0.3281	2 15/16	4 19/32	15.90
QD741	11/32	0.3438	3 3/16	4 29/32	17.90
BG118	23/64	0.3594	3 3/16	4 29/32	19.50
BG119	3/8	0.3750	3 7/16	5 1/4	20.90
BG120	25/64	0.3906	3 7/16	5 1/4	21.90
BG121	13/32	0.4062	3 7/16	5 1/4	22.90
BG122	27/64	0.4219	3 11/16	5 9/32	24.90
QD742	7/16	0.4375	3 11/16	5 9/32	26.90
BG123	29/64	0.4531	3 11/16	5 9/32	38.50
BG124	15/32	0.4688	3 31/32	5 15/16	31.50
BG125	31/64	0.4844	3 31/32	5 15/16	33.50
BG126	1/2	0.5000	3 31/32	5 15/16	35.50

Model No.	Letter Size	Decimal Size"	L2"	L1"	Price /Each
BG127	A	0.2340	2 5/8	3 7/8	10.50
BG128	B	0.2380	2 3/4	4	11.90
BG129	C	0.2420	2 3/4	4	11.90
BG130	D	0.2460	2 3/4	4	13.50
BG112	E	0.2500	2 1/2	3 31/32	8.79
BG131	F	0.2570	2 7/8	4 1/8	11.90
BG132	G	0.2610	2 7/8	4 1/8	11.90
BG133	H	0.2660	2 7/8	4 1/8	13.50
BG134	I	0.2720	2 7/8	4 1/8	12.50
BG135	J	0.2770	2 7/8	4 1/8	13.50
BG136	K	0.2810	2 15/16	4 1/4	13.50
BG137	L	0.2900	2 15/16	4 1/4	14.90
BG138	M	0.2950	3 1/16	4 3/8	15.90

Model No.	Letter Size	Decimal Size"	L2"	L1"	Price /Each
BG139	N	0.3020	3 1/16	4 3/8	15.90
BG140	O	0.3160	3 3/16	4 1/2	17.50
BG141	P	0.3230	3 5/16	4 5/8	18.90
BG142	Q	0.3320	3 7/16	4 3/4	19.50
BG143	R	0.3390	3 7/16	4 3/4	19.50
BG144	S	0.3480	3 1/2	4 7/8	23.90
BG145	T	0.3580	3 1/2	4 7/8	23.90
BG146	U	0.3680	3 5/8	5	23.90
BG147	V	0.3770	3 5/8	5	26.50
BG148	W	0.3860	3 3/4	5 1/8	26.50
BG149	X	0.3970	3 3/4	5 1/8	26.50
BG150	Y	0.4040	3 7/8	5 1/4	27.90
BG151	Z	0.4130	3 7/8	5 1/4	30.50

Model No.	Wire Gauge Size	Decimal Size"	L2"	L1"	Price /Each
BG211	60	0.0400	15/32	1 5/16	4.89
BG210	59	0.0410	15/32	1 5/16	4.89
BG209	58	0.0420	9/16	1 7/16	4.89
BG208	57	0.0430	9/16	1 7/16	4.89
BG207	56	0.0465	5/8	1 1/2	4.89
BG206	55	0.0520	5/8	1 1/2	4.29
BG205	54	0.0550	11/16	1 9/16	4.29
BG204	53	0.0595	25/32	1 11/16	4.29
BG203	52	0.0635	25/32	1 11/16	3.99
BG202	51	0.0670	7/8	1 13/16	3.99
BG201	50	0.0700	7/8	1 13/16	3.99
BG200	49	0.0730	7/8	1 13/16	3.99
BG199	48	0.0760	15/16	1 15/16	3.99
BG198	47	0.0785	15/16	1 15/16	3.99
BG197	46	0.0810	15/16	1 15/16	3.99
BG196	45	0.0820	15/16	1 15/16	3.99
BG195	44	0.0860	1 1/16	2 3/32	3.99
BG194	43	0.0890	1 1/16	2 3/32	3.99
BG193	42	0.0935	1 3/16	2 1/4	3.99
BG192	41	0.0960	1 3/16	2 1/4	4.09
BG191	40	0.0980	1 3/16	2 1/4	4.09
BG190	39	0.0995	1 3/16	2 1/4	4.09
BG189	38	0.1015	1 3/16	2 1/4	4.09
BG188	37	0.1040	1 3/16	2 1/4	4.39
BG187	36	0.1065	1 5/16	2 13/32	4.39
BG186	35	0.1100	1 5/16	2 13/32	4.39
BG185	34	0.1110	1 5/16	2 13/32	4.39
BG184	33	0.1130	1 5/16	2 13/32	4.39
BG183	32	0.1160	1 5/16	2 13/32	4.69
BG182	31	0.1200	1 7/16	2 9/16	4.69

Model No.	Wire Gauge Size	Decimal Size"	L2"	L1"	Price /Each
BG181	30	0.1285	1 7/16	2 9/16	4.79
BG180	29	0.1360	1 17/32	2 3/4	4.99
BG179	28	0.1405	1 17/32	2 3/4	5.29
BG178	27	0.1440	1 17/32	2 3/4	5.59
BG177	26	0.1470	1 17/32	2 3/4	5.59
BG176	25	0.1495	1 11/16	2 15/16	5.59
BG175	24	0.1520	1 11/16	2 15/16	6.19
BG174	23	0.1540	1 11/16	2 15/16	6.19
BG173	22	0.1570	1 11/16	2 15/16	6.19
BG172	21	0.1590	1 11/16	2 15/16	6.19
BG171	20	0.1610	1 11/16	2 15/16	6.19
BG170	19	0.1660	1 11/16	2 15/16	6.19
BG169	18	0.1695	1 27/32	3 5/32	6.39
BG168	17	0.1730	1 27/32	3 5/32	6.99
BG167	16	0.1770	1 27/32	3 5/32	7.19
BG166	15	0.1800	1 27/32	3 5/32	7.69
BG165	14	0.1820	1 27/32	3 5/32	7.69
BG164	13	0.1850	1 27/32	3 5/32	7.69
BG163	12	0.1890	2 1/16	3 3/8	7.99
BG162	11	0.1910	2 1/16	3 3/8	7.99
BG161	10	0.1935	2 1/16	3 3/8	7.99
BG160	9	0.1960	2 1/16	3 3/8	7.99
BG159	8	0.1990	2 1/16	3 3/8	7.99
BG158	7	0.2010	2 1/16	3 3/8	7.99
BG157	6	0.2040	2 1/16	3 3/8	10.50
BG156	5	0.2055	2 1/16	3 3/8	10.50
BG155	4	0.2090	2 1/4	3 21/32	10.50
BG154	3	0.2130	2 1/4	3 21/32	10.50
BG153	2	0.2210	2 1/4	3 21/32	10.90
BG152	1	0.2280	2 1/4	3 21/32	10.90

JOBBER LENGTH – COBALT (CONT'D)

Model No.	Size mm	DEC	L2 mm	L1 mm	Price /Each
BI021	1.00	0.0394	12.0	34.0	7.69
BI022	1.50	0.0591	18.0	40.0	5.89
BI023	1.60	0.0630	20.0	43.0	8.49
BI024	1.70	0.0669	20.0	43.0	8.29
BI025	1.80	0.0709	22.0	46.0	8.09
BI026	1.90	0.0748	22.0	46.0	7.99
BI027	2.00	0.0787	24.0	49.0	5.19
BI028	2.10	0.0827	24.0	49.0	7.79
BI029	2.20	0.0866	27.0	53.0	7.69
BI030	2.25	0.0886	27.0	53.0	7.69
BI031	2.30	0.0906	27.0	53.0	7.69
BI032	2.40	0.0945	30.0	57.0	7.59
BI033	2.50	0.0984	30.0	57.0	5.09
BI034	2.60	0.1024	30.0	57.0	7.69
BI035	2.70	0.1063	33.0	61.0	7.79
BI036	2.80	0.1102	33.0	61.0	7.79
BI037	2.90	0.1142	33.0	61.0	7.89
BI038	3.00	0.1181	33.0	61.0	5.39
BI039	3.10	0.1220	36.0	65.0	8.19
BI040	3.20	0.1260	36.0	65.0	8.29
BI041	3.30	0.1299	36.0	65.0	5.59
BI042	3.40	0.1339	39.0	70.0	8.59
BI043	3.50	0.1378	39.0	70.0	5.89
BI044	3.60	0.1417	39.0	70.0	8.99
BI045	3.70	0.1457	39.0	70.0	9.09
BI046	3.75	0.1476	39.0	70.0	10.90
BI047	3.80	0.1496	43.0	75.0	9.29
BI048	3.90	0.1535	43.0	75.0	9.59
BI049	4.00	0.1575	43.0	75.0	6.49
BI050	4.10	0.1614	43.0	75.0	9.99
BI051	4.20	0.1654	43.0	75.0	10.50
BI052	4.25	0.1673	43.0	75.0	10.50
BI053	4.30	0.1693	47.0	80.0	10.50
BI054	4.40	0.1732	47.0	80.0	10.90
BI055	4.50	0.1772	47.0	80.0	7.39
BI056	4.60	0.1811	47.0	80.0	11.50
BI057	4.70	0.1850	47.0	80.0	11.90
BI058	4.80	0.1890	52.0	86.0	11.90
BI059	4.90	0.1929	52.0	86.0	12.50
BI060	5.00	0.1969	52.0	86.0	8.29

Model No.	Size mm	DEC	L2 mm	L1 mm	Price /Each
BI061	5.10	0.2008	52.0	86.0	12.90
BI062	5.20	0.2047	52.0	86.0	13.50
BI063	5.30	0.2087	52.0	86.0	13.90
BI064	5.40	0.2126	57.0	93.0	13.90
BI065	5.50	0.2165	57.0	93.0	9.59
BI066	5.60	0.2205	57.0	93.0	14.90
BI067	5.70	0.2244	57.0	93.0	15.50
TBL002	5.80	0.2283	57.0	93.0	15.90
TBL003	5.90	0.2323	57.0	93.0	15.90
BI068	6.00	0.2362	57.0	93.0	10.90
BI069	6.10	0.2402	63.0	101.0	16.90
BI070	6.20	0.2441	63.0	101.0	17.50
BI071	6.30	0.2480	63.0	101.0	18.50
BI072	6.40	0.2520	63.0	101.0	18.50
BI073	6.50	0.2559	63.0	101.0	12.50
BI074	6.60	0.2598	63.0	101.0	19.50
TBL004	6.70	0.2638	63.0	101.0	19.90
BI075	6.80	0.2677	69.0	109.0	20.50
BI076	6.90	0.2717	69.0	109.0	20.50
BI077	7.00	0.2756	69.0	109.0	14.50
TBL005	7.10	0.2795	69.0	109.0	21.90
BI078	7.20	0.2835	69.0	109.0	22.90
BI079	7.30	0.2874	69.0	109.0	23.50
BI080	7.40	0.2913	69.0	109.0	23.90
BI081	7.50	0.2953	69.0	109.0	16.50
BI082	7.60	0.2992	75.0	117.0	24.90
BI083	7.70	0.3031	75.0	117.0	25.50
BI084	7.80	0.3071	75.0	117.0	25.90
BI085	7.90	0.3110	75.0	117.0	26.90
BI086	8.00	0.3150	75.0	117.0	18.50
BI087	8.10	0.3189	75.0	117.0	28.50
BI088	8.20	0.3228	75.0	117.0	29.50
BI089	8.30	0.3268	75.0	117.0	29.90
BI090	8.40	0.3307	75.0	117.0	30.50
BI091	8.50	0.3346	75.0	117.0	20.50
BI092	8.60	0.3386	81.0	125.0	31.90
BI093	8.70	0.3425	81.0	125.0	32.90
BI094	8.80	0.3465	81.0	125.0	33.50
BI095	8.90	0.3504	81.0	125.0	33.90
BI096	9.00	0.3543	81.0	125.0	23.90

Model No.	Size mm	DEC	L2 mm	L1 mm	Price /Each
BI097	9.10	0.3583	81.0	125.0	35.90
BI098	9.20	0.3622	81.0	125.0	36.90
BI099	9.30	0.3661	81.0	125.0	37.90
BI100	9.40	0.3701	81.0	125.0	38.50
BI101	9.50	0.3740	81.0	125.0	25.90
TBL006	9.60	0.3780	87.0	133.0	39.90
BI102	9.70	0.3819	87.0	133.0	40.90
BI103	9.80	0.3858	87.0	133.0	42.50
BI104	9.90	0.3898	87.0	133.0	43.50
BI105	10.00	0.3937	87.0	133.0	29.50
BI106	10.10	0.3976	87.0	133.0	48.50
BI107	10.20	0.4016	87.0	133.0	46.50
BI108	10.30	0.4055	87.0	133.0	48.50
BI109	10.40	0.4094	87.0	133.0	50.50
BI110	10.50	0.4134	87.0	133.0	49.50
BI111	10.60	0.4173	87.0	133.0	57.50
BI112	10.70	0.4213	94.0	142.0	59.90
BI113	10.80	0.4252	94.0	142.0	61.90
BI114	10.90	0.4291	94.0	142.0	64.50
BI115	11.00	0.4331	94.0	142.0	36.50
BI116	11.10	0.4370	94.0	142.0	65.50
BI117	11.20	0.4409	94.0	142.0	66.90
BI118	11.30	0.4449	94.0	142.0	67.90
BI119	11.40	0.4488	94.0	142.0	68.50
BI120	11.50	0.4528	94.0	142.0	60.50
BI121	11.60	0.4567	94.0	142.0	69.90
BI122	11.70	0.4606	94.0	142.0	70.90
BI123	11.80	0.4646	94.0	142.0	70.90
BI124	11.90	0.4685	101.0	151.0	71.50
BI125	12.00	0.4724	101.0	151.0	44.50
BI126	12.10	0.4764	101.0	151.0	75.50
BI127	12.20	0.4803	101.0	151.0	87.50
BI128	12.30	0.4843	101.0	151.0	88.90
BI129	12.40	0.4882	101.0	151.0	90.90
BI130	12.50	0.4921	101.0	151.0	73.90
BI131	13.00	0.5118	101.0	151.0	71.50
BI132	13.50	0.5315	101.0	151.0	89.50
BI133	14.00	0.5512	101.0	151.0	97.90
BI134	14.50	0.5709	114.0	169.0	105.00





JOBBER LENGTH HIGH SPEED STEEL SETS



WJ188

BLACK & GOLD MULTI APPLICATION

- Industrial duty
- Right hand 135° split point eliminates walking
- General purpose used on steels, cast iron and most non-ferrous metals
- Machine and portable drilling applications
- Two-tone black oxide and bronze finish provides ideal chip flow and resistance to abrasion
- Steel case

FRACTIONAL SETS

Model No.	Description	Size"	Price/Each
QR040	13-piece set	1/16 to 1/4 by 64ths	42.50
BG060	15-piece set	1/16 to 1/2 by 32nds	125.00
BG063	21-piece set	1/16 to 3/8 by 64ths	115.00
WJ188	29-piece set	1/16 to 1/2 by 64ths	189.00

METRIC SETS

Model No.	Description	Size mm	Price/Each
BG057	11-piece set	1.5 to 6.5 by 0.5	76.50
BG061	19-piece set	1.0 to 10.0 by 0.5	109.00
BG064	25-piece set	1.0 to 13.0 by 0.5	159.00
BG058	50-piece set	1.0 to 5.9 by 0.1	129.00
BG059	41-piece set	6.0 to 10.0 by 0.1	309.00

WIRE GAUGE & LETTER SETS

Model No.	Description	Sizes	Price/Each
BG066	60-piece set	#1 to #60	179.00
BG062	20-piece set	#61 to #80	79.50
BG065	26-piece set	Letter A to Z	245.00

CLARKSON OSBORN



QF420

HYPER

- Maintenance duty
- Right hand, 118° point
- General purpose used on steels, cast iron and most non-ferrous metals
- Machine and portable drilling applications
- Black oxide finish
- Steel case

FRACTIONAL SETS

Model No.	Description	Size"	Price/Each
BM889	13-piece set	1/16 to 1/4 by 64ths	32.50
BM890	15-piece set	1/16 to 1/2 by 32nds	68.50
BM891	21-piece set	1/16 to 3/8 by 64ths	57.50
QF420	29-piece set	1/16 to 1/2 by 64ths	105.00

WIRE GAUGE & LETTER SETS

Model No.	Description	Sizes	Price/Each
BM897	60-piece set	#1 to #60	98.50
BM892	26-piece set	Letter A to Z	139.00

JOBBER LENGTH – COBALT

- M42 cobalt provides wear and heat resistance
- Straight shank, 2 flute design
- Right hand cutting direction
- 135° split point, self-centring eliminates walking
- Bright finish

Applications

For general purpose drilling to heavy-duty operations in high tensile strength steel and alloys, stainless steels and other ferrous metals

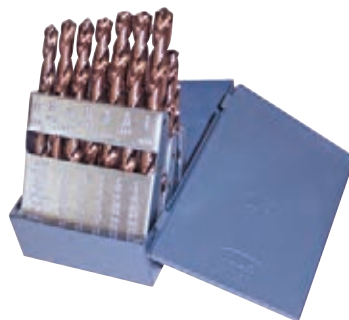

CLARKSON OSBORN

FRACTIONAL SETS

Model No.	Description	Sizes	Price/Each
BG067	15-piece set	1/16" to 1/2" by 32nds	215.00
BG069	21-piece set	1/16" to 3/8" by 64ths	199.00
BG071	29-piece set	1/16" to 1/2" by 64ths	415.00

METRIC SETS

Model No.	Description	Sizes	Price/Each
BG068	19-piece set	1.0 mm to 10.0 mm by 0.5 mm	275.00
BG070	25-piece set	1.0 mm to 13.0 mm by 0.5 mm	605.00

JOBBER LENGTH DRILL BIT SET

- Industrial-duty 29 piece drill bit set
- For use on steels, cast iron, and most non-ferrous metals
- Two-tone black oxide finish provides ideal chip flow and resistance to abrasion
- Includes: (1) Steel case, (29) Drill bits from 1/16" - 1/2" by 64ths
- No. of Pieces: 29
- Material: High Speed Steel
- Finish: Black Oxide
- Shank Type: Round

Model No. TCT047
Price/Each \$135.00

AURORA
TOOLS



JOBBER DRILLS 118°

A012 SERIES

- Low thrust design with self centering split point makes for easier penetration
- TiN coated tip increases surface hardness and improves tool life
- Material: High Speed Steel
- Point Angle: 118°
- Manufacturing Standards: ANSI
- Finish: TiN Tip and Bright Body
- Cutting Direction: Right Hand

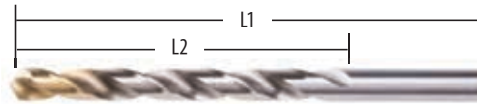

A012 SERIES - FRACTIONAL SIZE

Model No.	Fractional Size"	Decimal Size"	L2"	L1"	Price /Each
TC0714*	1/64	0.0156	3/16	3/4	3.91
TC0726*	1/32	0.0313	1/2	1-3/8	2.72
TC0739*	3/64	0.0469	3/4	1-3/4	2.72
TC0743*	1/16	0.0625	7/8	1-7/8	2.37
TC0749*	5/64	0.0781	1	2	2.37
TC0756	3/32	0.0938	1-1/4	2-1/4	2.51
TC0763	7/64	0.1094	1-1/2	2-5/8	2.67
TC0769	1/8	0.125	1-5/8	2-3/4	2.67
TC0773	9/64	0.1406	1-3/4	2-7/8	2.92
TC0779	5/32	0.1563	2	3-1/8	2.96
TC0785	11/64	0.1719	2-1/8	3-1/4	3.09
TC0791	3/16	0.1875	2-5/16	3-1/2	3.54
TC0798	13/64	0.2031	2-7/16	3-5/8	3.98
TC0803	7/32	0.2188	2-1/2	3-3/4	4.41
TC0807	15/64	0.2344	2-5/8	3-7/8	4.74
TC0811	1/4	0.25	2-3/4	4	5.08
TC0815	17/64	0.2656	2-7/8	4-1/8	6.08
TC0820	9/32	0.2813	2-15/16	4-1/4	6.31
TC0823	19/64	0.2968	3-1/16	4-3/8	7.29
TC0825	5/16	0.3125	3-3/16	4-1/2	8.11
TC0828	21/64	0.3281	3-5/16	4-5/8	8.96
TC0831	11/32	0.3437	3-7/16	4-3/4	9.98
TC0834	23/64	0.3594	3-1/2	4-7/8	11.30

*No split point or TiN tip

A012 SERIES - WIRE GAUGE SIZE

Model No.	Wire Gauge Size	Decimal Size"	L2"	L1"	Price /Each
TC0712*	80	0.0135	1/8	3/4	5.01
TC0713*	79	0.0145	1/8	3/4	5.01
TC0715*	78	0.016	3/16	7/8	5.01
TC0716*	77	0.018	3/16	7/8	3.61
TC0717*	76	0.02	3/16	7/8	3.61
TC0718*	75	0.021	1/4	1	3.61
TC0719*	74	0.0225	1/4	1	3.61
TC0720*	73	0.024	5/16	1-1/8	3.61
TC0721*	72	0.025	5/16	1-1/8	3.61
TC0722*	71	0.026	3/8	1-1/4	3.61
TC0723*	70	0.028	3/8	1-1/4	3.06
TC0724*	69	0.0292	1/2	1-3/8	3.06
TC0725*	68	0.031	1/2	1-3/8	2.77
TC0727*	67	0.032	1/2	1-3/8	2.77
TC0728*	66	0.033	1/2	1-3/8	2.77
TC0729*	65	0.035	5/8	1-1/2	2.77
TC0730*	64	0.036	5/8	1-1/2	2.77
TC0731*	63	0.037	5/8	1-1/2	2.77
TC0732*	62	0.038	5/8	1-1/2	2.77
TC0733*	61	0.039	11/16	1-5/8	2.77
TC0734*	60	0.04	11/16	1-5/8	2.72
TC0735*	59	0.041	11/16	1-5/8	2.72
TC0736*	58	0.042	11/16	1-5/8	2.72
TC0737*	57	0.043	3/4	1-3/4	2.72
TC0738*	56	0.0465	3/4	1-3/4	2.72
TC0740*	55	0.052	7/8	1-7/8	2.72
TC0741*	54	0.055	7/8	1-7/8	2.72
TC0742*	53	0.0595	7/8	1-7/8	2.72
TC0744*	52	0.0635	7/8	1-7/8	2.46
TC0745*	51	0.0669	1	2	2.46
TC0746*	50	0.07	1	2	2.46
TC0747*	49	0.073	1	2	2.46
TC0748*	48	0.076	1	2	2.46
TC0750*	47	0.0785	1	2	2.46
TC0751	46	0.081	1-1/8	2-1/8	2.51
TC0752	45	0.082	1-1/8	2-1/8	2.51
TC0753	44	0.086	1-1/8	2-1/8	2.51
TC0754	43	0.089	1-1/4	2-1/4	2.51
TC0755	42	0.0935	1-1/4	2-1/4	2.51
TC0757	41	0.096	1-3/8	2-3/8	2.51

Model No.	Fractional Size"	Decimal Size"	L2"	L1"	Price /Each
TC0836	3/8	0.375	3-5/8	5	11.60
TC0839	25/64	0.3906	3-3/4	5-1/8	13.20
TC0842	13/32	0.4063	3-7/8	5-1/4	13.60
TC0844	27/64	0.4219	3-15/16	5-3/8	15.00
TC0845	7/16	0.4375	4-1/16	5-1/2	15.60
TC0846	29/64	0.4531	4-3/16	5-5/8	17.40
TC0847	15/32	0.4687	4-5/16	5-3/4	18.60
TC0848	31/64	0.4844	4-3/8	5-7/8	19.50
TC0849	1/2	0.5	4-1/2	6	19.80
TC0850	33/64	0.5156	4-13/16	6-5/8	36.40
TC0851	17/32	0.5313	4-13/16	6-5/8	38.30
TC0852	35/64	0.5469	4-13/16	6-5/8	41.40
TC0853	9/16	0.5625	4-13/16	6-5/8	43.40
TC0854	37/64	0.5781	4-13/16	6-5/8	43.70
TC0855	19/32	0.5937	5-3/16	7-1/8	44.40
TC0856	39/64	0.6094	5-3/16	7-1/8	48.70
TC0857	5/8	0.625	5-3/16	7-1/8	47.70
TC0858	21/32	0.6563	5-3/16	7-1/8	50.70
TC0859	11/16	0.6875	5-5/8	7-5/8	57.80
TC0860	45/64	0.7031	5-5/8	7-5/8	82.40
TC0861	23/32	0.7188	5-5/8	7-5/8	87.00
TC0862	47/64	0.7344	6	8	92.30
TC0863	3/4	0.75	6	8	98.10

CUTTING TOOLS

JOBBER DRILLS (CONT'D)

A012 SERIES - LETTER SIZE

Model No.	Letter Size	Decimal Size"	L2"	L1"	Price /Each
TC0806	A	0.234	2-5/8	3-7/8	5.93
TC0808	B	0.238	2-3/4	4	5.93
TC0809	C	0.242	2-3/4	4	5.93
TC0810	D	0.246	2-3/4	4	5.93
TC0812	E	0.25	2-3/4	4	5.08
TC0813	F	0.257	2-7/8	4-1/8	6.34
TC0814	G	0.261	2-7/8	4-1/8	7.09
TC0816	H	0.266	2-7/8	4-1/8	7.09
TC0817	I	0.272	2-7/8	4-1/8	7.09
TC0818	J	0.277	2-7/8	4-1/8	7.63
TC0819	K	0.281	2-15/16	4-1/4	8.38
TC0821	L	0.29	2-15/16	4-1/4	8.38
TC0822	M	0.295	3-1/16	4-3/8	8.91

Model No.	Letter Size	Decimal Size"	L2"	L1"	Price /Each
TC0824	N	0.302	3-1/16	4-3/8	9.05
TC0826	O	0.316	3-3/16	4-1/2	9.05
TC0827	P	0.323	3-5/16	4-5/8	10.20
TC0829	Q	0.332	3-7/16	4-3/4	10.20
TC0830	R	0.339	3-7/16	4-3/4	10.90
TC0832	S	0.348	3-1/2	4-7/8	11.60
TC0833	T	0.358	3-1/2	4-7/8	13.20
TC0835	U	0.368	3-5/8	5	13.20
TC0837	V	0.377	3-5/8	5	13.60
TC0838	W	0.386	3-3/4	5-1/8	14.00
TC0840	X	0.397	3-3/4	5-1/8	16.90
TC0841	Y	0.404	3-7/8	5-1/4	19.10
TC0843	Z	0.413	3-7/8	5-1/4	20.30

JOBBER DRILLS 118°

- Material: High Speed Steel
- Point Angle: 118°
- Manufacturing Standards: ANSI
- Cutting Direction: Right Hand

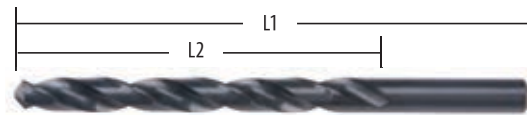

R10 SERIES - FRACTIONAL SIZE

- Steam oxide finish reduces wear and chip welding in harder ferrous materials for increased wear resistance and lubricity

Model No.	Fractional Size"	Decimal Size"	L2"	L1"	Price /Each
TDB875	1/64	0.0156	3/16	3/4	3.11
TDB876	1/32	0.0313	1/2	1-3/8	1.89
TDB877	3/64	0.0469	3/4	1-3/4	1.89
TDB878	1/16	0.0625	7/8	1-7/8	1.74
TDB879	5/64	0.0781	1	2	1.77
TC0869	3/32	0.0938	1-1/4	2-1/4	1.77
TDB881	7/64	0.1094	1-1/2	2-5/8	1.84
TDB882	1/8	0.125	1-5/8	2-3/4	1.79
TDB883	9/64	0.1406	1-3/4	2-7/8	1.99
TDB884	5/32	0.1563	2	3-1/8	2.02
TDB885	11/64	0.1719	2-1/8	3-1/4	2.21
TDB886	3/16	0.1875	2-5/16	3-1/2	2.44
MLN282	13/64	0.2031	2-7/16	3-5/8	2.71
TDB888	7/32	0.2188	2-1/2	3-3/4	3.01
TDB889	15/64	0.2344	2-5/8	3-7/8	3.26
TDB890	1/4	0.25	2-3/4	4	3.41
TDB891	17/64	0.2656	2-7/8	4-1/8	4.18
TDB892	9/32	0.2813	2-15/16	4-1/4	4.28
TDB893	19/64	0.2969	3-1/16	4-3/8	4.99
TDB894	5/16	0.3125	3-3/16	4-1/2	5.49
TDB895	21/64	0.3281	3-5/16	4-5/8	6.08
TDB896	11/32	0.3437	3-7/16	4-3/4	6.79

Model No.	Fractional Size"	Decimal Size"	L1"	L2"	Price /Each
TDB897	23/64	0.3594	3-1/2	4-7/8	7.66
TDB898	3/8	0.375	3-5/8	5	7.74
TDB899	25/64	0.3906	3-3/4	5-1/8	8.96
TDB900	13/32	0.4063	3-7/8	5-1/4	9.16
TDB901	27/64	0.4219	3-15/16	5-3/8	10.30
TDB902	7/16	0.4375	4-1/16	5-1/2	10.60
TDB903	29/64	0.4531	4-3/16	5-5/8	11.90
TDB904	15/32	0.4687	4-5/16	5-3/4	12.70
TDB905	31/64	0.4844	4-3/8	5-7/8	13.20
UU377	1/2	0.5	4-1/2	6	13.20
TDB907	33/64	0.5156	4-13/16	6-5/8	24.00
TDB908	17/32	0.5313	4-13/16	6-5/8	24.70
TDB909	35/64	0.5469	4-13/16	6-5/8	27.20
TDB910	9/16	0.5625	4-13/16	6-5/8	28.10
TC0900	37/64	0.5781	4-13/16	6-5/8	29.40
TDB912	19/32	0.5937	5-3/16	7-1/8	29.40
TDB913	39/64	0.6094	5-3/16	7-1/8	31.50
TDB915	41/64	0.6406	5-3/16	7-1/8	34.90
TDB916	21/32	0.6563	5-3/16	7-1/8	36.50
TDB917	43/64	0.6719	5-5/8	7-5/8	39.40
TC0907	11/16	0.6875	5-5/8	7-5/8	39.40

R10P SERIES - FRACTIONAL SIZE

- Bright finish improves chip flow in soft or non-ferrous materials

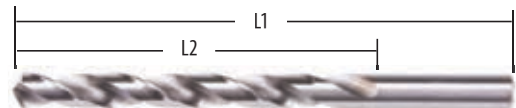

Model No.	Fractional Size"	Decimal Size"	L2"	L1"	Price /Each
TC0908	1/64	0.0156	3/16	3/4	4.36
TC0909	1/32	0.0313	1/2	1-3/8	2.66
TC0910	3/64	0.0469	3/4	1-3/4	2.66
TC0911	1/16	0.0625	7/8	1-7/8	2.44
TC0912	5/64	0.0781	1	2	2.47
TC0913	3/32	0.0938	1-1/4	2-1/4	2.47
TC0914	7/64	0.1094	1-1/2	2-5/8	2.59
TC0915	1/8	0.125	1-5/8	2-3/4	2.51
TC0916	9/64	0.1406	1-3/4	2-7/8	2.79
TC0917	5/32	0.1563	2	3-1/8	2.84
TC0918	11/64	0.1719	2-1/8	3-1/4	3.09
TC0919	3/16	0.1875	2-5/16	3-1/2	3.42
TC0920	13/64	0.2031	2-7/16	3-5/8	3.79
TC0921	7/32	0.2188	2-1/2	3-3/4	4.23
TC0922	15/64	0.2344	2-5/8	3-7/8	4.58
TC0923	1/4	0.25	2-3/4	4	4.76
TC0924	17/64	0.2656	2-7/8	4-1/8	5.81
TC0925	9/32	0.2813	2-15/16	4-1/4	5.99
TC0926	19/64	0.2969	3-1/16	4-3/8	6.98
TC0927	5/16	0.3125	3-3/16	4-1/2	7.68
TC0928	21/64	0.3281	3-5/16	4-5/8	8.50
TC0929	11/32	0.3437	3-7/16	4-3/4	9.51

Model No.	Fractional Size"	Decimal Size"	L2"	L1"	Price /Each
TC0930	23/64	0.3594	3-1/2	4-7/8	10.80
TC0931	3/8	0.375	3-5/8	5	10.90
TC0932	25/64	0.3906	3-3/4	5-1/8	12.60
TC0933	13/32	0.4063	3-7/8	5-1/4	12.90
TC0934	27/64	0.4219	3-15/16	5-3/8	14.40
TC0935	7/16	0.4375	4-1/16	5-1/2	14.90
TC0936	29/64	0.4531	4-3/16	5-5/8	16.60
TC0937	15/32	0.4687	4-5/16	5-3/4	17.70
TC0938	31/64	0.4844	4-3/8	5-7/8	18.50
TC0939	1/2	0.5	4-1/2	6	18.50
TC0940	33/64	0.5156	4-13/16	6-5/8	33.60
TC0941	17/32	0.5313	4-13/16	6-5/8	34.60
TC0942	35/64	0.5469	4-13/16	6-5/8	38.10
TC0943	9/16	0.5625	4-13/16	6-5/8	39.30
TC0944	37/64	0.5781	4-13/16	6-5/8	40.00
TC0945	19/32	0.5937	5-3/16	7-1/8	41.20
TC0946	39/64	0.6094	5-3/16	7-1/8	44.10
TC0947	5/8	0.625	5-3/16	7-1/8	43.30
TC0948	41/64	0.6406	5-3/16	7-1/8	48.90
TC0949	21/32	0.6563	5-3/16	7-1/8	51.10
TC0950	43/64	0.6719	5-5/8	7-5/8	55.20
TC0951	11/16	0.6875	5-5/8	7-5/8	55.20

JOBBER DRILLS 118° (CONT.)

R18 SERIES - WIRE GAUGE SIZE

- Steam oxide finish reduces wear and chip welding in harder ferrous materials for increased wear resistance and lubricity

Model No.	Wire Gauge Size	Decimal Size"	L2"	L1"	Price /Each
TDD155	80	0.0135	1/8	3/4	3.14
TDD154	79	0.0145	1/8	3/4	3.14
TDD153	78	0.016	3/16	7/8	2.61
TDD152	77	0.018	3/16	7/8	2.61
TDD151	76	0.02	3/16	7/8	2.61
TDD150	75	0.021	1/4	1	2.61
TDD149	74	0.0225	1/4	1	2.61
TDD148	73	0.024	5/16	1-1/8	2.61
TDD147	72	0.025	5/16	1-1/8	2.61
TCP013	71	0.026	3/8	1-1/4	2.61
TDD145	70	0.028	3/8	1-1/4	2.11
TDD144	69	0.0292	1/2	1-3/8	2.11
TDD143	68	0.031	1/2	1-3/8	1.92
TDD142	67	0.032	1/2	1-3/8	1.92
TDD141	66	0.033	1/2	1-3/8	1.92
TDD140	65	0.035	5/8	1-1/2	1.92
TCP020	64	0.036	5/8	1-1/2	1.92
TDD138	63	0.037	5/8	1-1/2	1.92
TDD137	62	0.038	5/8	1-1/2	1.92
TDD136	61	0.039	11/16	1-5/8	1.92
TDD135	60	0.04	11/16	1-5/8	1.87
TDD134	59	0.041	11/16	1-5/8	1.87
TDD133	58	0.042	11/16	1-5/8	1.87
TDD132	57	0.043	3/4	1-3/4	1.87
TDD131	56	0.0465	3/4	1-3/4	1.87
TDD130	55	0.052	7/8	1-7/8	1.87
TDD129	54	0.055	7/8	1-7/8	1.87
TDD128	53	0.0595	7/8	1-7/8	1.87
TDD127	52	0.0635	7/8	1-7/8	1.77
TDD126	51	0.067	1	2	1.77
TDD125	50	0.07	1	2	1.77
TDD124	49	0.073	1	2	1.77
TDD123	48	0.076	1	2	1.77
TDD122	47	0.0785	1	2	1.77
TDD121	46	0.081	1-1/8	2-1/8	1.77
TDD120	45	0.082	1-1/8	2-1/8	1.77
TDD119	44	0.086	1-1/8	2-1/8	1.77
TDD118	43	0.089	1-1/4	2-1/4	1.77
TDD117	42	0.0935	1-1/4	2-1/4	1.77
TDD116	41	0.096	1-3/8	2-3/8	1.74

R18P SERIES - WIRE GAUGE SIZE

- Bright finish improves chip flow in soft or non-ferrous materials

Model No.	Wire Gauge Size	Decimal Size"	L2"	L1"	Price /Each
TCP084	97	0.0059	1/16	3/4	22.90
TCP085	96	0.0063	1/16	3/4	22.90
TCP086	95	0.0067	1/16	3/4	20.70
TCP087	94	0.0071	1/16	3/4	20.70
TCP088	93	0.0075	1/16	3/4	14.40
TCP089	92	0.0079	1/16	3/4	14.40
TCP090	91	0.0083	5/64	3/4	14.40
TCP091	90	0.0087	5/64	3/4	14.40
TCP092	89	0.0091	5/64	3/4	14.40
TCP093	88	0.0095	5/64	3/4	14.40
TCP094	87	0.01	5/64	3/4	11.40
TCP095	86	0.0105	3/32	3/4	11.40
TCP096	85	0.011	3/32	3/4	10.30
TCP097	84	0.0115	3/32	3/4	10.30
TCP098	83	0.012	3/32	3/4	10.30
TCP099	82	0.0125	3/32	3/4	8.91
TCP100	81	0.013	3/32	3/4	8.91
TCP101	80	0.0135	1/8	3/4	4.41
TCP102	79	0.0145	1/8	3/4	4.41
TCP103	78	0.016	3/16	7/8	3.66
TCP104	77	0.018	3/16	7/8	3.66
TCP105	76	0.02	3/16	7/8	3.66
TCP106	75	0.021	1/4	1	3.66
TCP107	74	0.0225	1/4	1	3.66
TCP108	73	0.024	5/16	1-1/8	3.66
TCP109	72	0.025	5/16	1-1/8	3.66
TCP110	71	0.026	3/8	1-1/4	3.66
TCP111	70	0.028	3/8	1-1/4	2.94

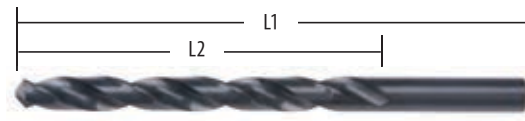

Model No.	Wire Gauge Size	Decimal Size"	L2"	L1"	Price /Each
TDD115	40	0.098	1-3/8	2-3/8	1.74
TDD114	39	0.0995	1-3/8	2-3/8	1.77
TDD113	38	0.1015	1-7/16	2-1/2	1.77
TDD112	37	0.104	1-7/16	2-1/2	1.77
TDD111	36	0.1065	1-7/16	2-1/2	1.74
TDD110	35	0.11	1-1/2	2-5/8	1.77
TDD109	34	0.111	1-1/2	2-5/8	1.77
TDD108	33	0.113	1-1/2	2-5/8	1.77
TDD107	32	0.116	1-5/8	2-3/4	1.77
TDD106	31	0.12	1-5/8	2-3/4	1.77
TDD105	30	0.1285	1-5/8	2-3/4	1.79
TDD104	29	0.136	1-3/4	2-7/8	1.79
TO075	28	0.1405	1-3/4	2-7/8	1.81
TDD102	27	0.144	1-7/8	3	1.94
TDD101	26	0.147	1-7/8	3	1.96
TDD100	25	0.1495	1-7/8	3	1.94
TDD099	24	0.152	2	3-1/8	2.06
TDD098	23	0.154	2	3-1/8	2.06
TDD097	22	0.157	2	3-1/8	2.06
TDD096	21	0.159	2-1/8	3-1/4	2.02
TDD095	20	0.161	2-1/8	3-1/4	2.21
TDD094	19	0.166	2-1/8	3-1/4	2.21
TDD093	18	0.1695	2-1/8	3-1/4	2.22
TDD092	17	0.173	2-3/16	3-3/8	2.66
TDD091	16	0.177	2-3/16	3-3/8	2.66
TDD090	15	0.18	2-3/16	3-3/8	2.66
TDD089	14	0.182	2-3/16	3-3/8	2.66
TDD088	13	0.185	2-5/16	3-1/2	2.66
TDD087	12	0.189	2-5/16	3-1/2	2.72
TDD086	11	0.191	2-5/16	3-1/2	2.71
TDD085	10	0.1935	2-7/16	3-5/8	2.91
TDD084	9	0.196	2-7/16	3-5/8	2.94
TDD083	8	0.199	2-7/16	3-5/8	2.94
TDD082	7	0.201	2-7/16	3-5/8	2.89
TDD081	6	0.204	2-1/2	3-3/4	3.34
TDD080	5	0.2055	2-1/2	3-3/4	3.34
TDD079	4	0.209	2-1/2	3-3/4	3.34
TDD078	3	0.213	2-1/2	3-3/4	3.31
TDD077	2	0.221	2-5/8	3-7/8	3.66
TDD076	1	0.228	2-5/8	3-7/8	3.64

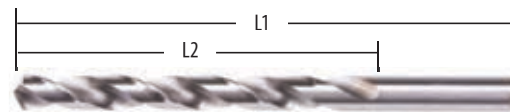

CUTTING TOOLS



R18P SERIES - WIRE GAUGE SIZE (CONT.)

Model No.	Wire Gauge Size	Decimal Size"	L2"	L1"	Price /Each
TCP140	41	0.096	1-3/8	2-3/8	2.47
TCP141	40	0.098	1-3/8	2-3/8	2.44
TCP142	39	0.0995	1-3/8	2-3/8	2.47
TCP143	38	0.1015	1-7/16	2-1/2	2.47
TCP144	37	0.104	1-7/16	2-1/2	2.47
TCP145	36	0.1065	1-7/16	2-1/2	2.44
TCP146	35	0.11	1-1/2	2-5/8	2.47
TCP147	34	0.111	1-1/2	2-5/8	2.47
TCP148	33	0.113	1-1/2	2-5/8	2.47
TCP149	32	0.116	1-5/8	2-3/4	2.47
TCP150	31	0.12	1-5/8	2-3/4	2.47
TCP151	30	0.1285	1-5/8	2-3/4	2.49
TCP152	29	0.136	1-3/4	2-7/8	2.49
TCP153	28	0.1405	1-3/4	2-7/8	2.54
TCP154	27	0.144	1-7/8	3	2.72
TCP155	26	0.147	1-7/8	3	2.74
TCP156	25	0.1495	1-7/8	3	2.72
TCP157	24	0.152	2	3-1/8	2.87
TCP158	23	0.154	2	3-1/8	2.87
TCP159	22	0.157	2	3-1/8	2.87
TCP160	21	0.159	2-1/8	3-1/4	2.84

R15 SERIES - LETTER SIZE

- Steam oxide finish reduces wear and chip welding in harder ferrous materials for increased wear resistance and lubricity

Model No.	Letter Size	Decimal Size"	L2"	L1"	Price /Each
TC0952	A	0.234	2-5/8	3-7/8	4.13
TC0953	B	0.2374	2-3/4	4	4.13
TC0954	C	0.2421	2-3/4	4	4.13
TC0955	D	0.2461	2-3/4	4	4.13
TC0957	F	0.2571	2-7/8	4-1/8	4.41
TC0958	G	0.261	2-7/8	4-1/8	4.94
TC0959	H	0.2661	2-7/8	4-1/8	4.94
TC0960	I	0.272	2-7/8	4-1/8	4.94
TC0961	J	0.2772	2-7/8	4-1/8	5.29
TC0962	K	0.2811	2-15/16	4-1/4	5.86
TC0963	L	0.2902	2-15/16	4-1/4	5.86
TC0964	M	0.2949	3-1/16	4-3/8	6.18
TC0965	N	0.302	3-1/16	4-3/8	6.18
TC0966	O	0.3161	3-3/16	4-1/2	6.26
TC0967	P	0.3228	3-5/16	4-5/8	7.13
TC0968	Q	0.3319	3-7/16	4-3/4	7.13
TC0969	R	0.339	3-7/16	4-3/4	7.54
TC0970	S	0.348	3-1/2	4-7/8	8.03
TC0971	T	0.358	3-1/2	4-7/8	9.13
TC0972	U	0.368	3-5/8	5	9.13
TC0973	V	0.3772	3-5/8	5	9.36
TC0974	W	0.3858	3-3/4	5-1/8	9.71
TC0975	X	0.3969	3-3/4	5-1/8	11.80
TC0976	Y	0.4039	3-7/8	5-1/4	13.20
TC0977	Z	0.413	3-7/8	5-1/4	14.10

JOBBER DRILLS 135°

- Low thrust design and self-centering split point makes for easier penetration
- Unique surface treatment for improved wear resistance in hard ferrous alloys
- Material: High Speed Steel • Point Angle: 135°
- Manufacturing Standards: ANSI
- Finish: Purple and Bronze • Cutting Direction: Right Hand

HX10 SERIES - FRACTIONAL SIZE

Model No.	Fractional Size"	Decimal Size"	L2"	L1"	Price /Each
TDE104	1/16	0.0625	7/8	1-7/8	2.57
TDE105	5/64	0.0781	1	2	2.57
TDE106	3/32	0.0938	1-1/4	2-1/4	2.57
TDE107	7/64	0.1094	1-1/2	2-5/8	2.72
TDE108	1/8	0.125	1-5/8	2-3/4	2.72
TDE109	9/64	0.1406	1-3/4	2-7/8	2.94
TDE110	5/32	0.1563	2	3-1/8	3.01
TDE111	11/64	0.1719	2-1/8	3.25	3.26
TDE112	3/16	0.1875	2-5/16	3-1/2	3.64
TDE113	13/64	0.2031	2-7/16	3-5/8	3.98
TDE114	7/32	0.2188	2-1/2	3-3/4	4.43
TDE115	15/64	0.2344	2-5/8	3-7/8	4.79
TDE116	1/4	0.25	2-3/4	4	5.09
TDE117	17/64	0.2656	2-7/8	4-1/8	6.13
TDE118	9/32	0.2813	2-15/16	4-1/4	6.31

Model No.	Wire Gauge Size	Decimal Size"	L2"	L1"	Price /Each
TCP161	20	0.161	2-1/8	3-1/4	3.07
TCP162	19	0.166	2-1/8	3-1/4	3.07
TCP163	18	0.1695	2-1/8	3-1/4	3.11
TCP164	17	0.173	2-3/16	3-3/8	3.72
TCP165	16	0.177	2-3/16	3-3/8	3.72
TCP166	15	0.18	2-3/16	3-3/8	3.72
TCP167	14	0.182	2-3/16	3-3/8	3.72
TCP168	13	0.185	2-5/16	3-1/2	3.72
TCP169	12	0.189	2-5/16	3-1/2	3.82
TCP170	11	0.191	2-5/16	3-1/2	3.79
TCP171	10	0.1935	2-7/16	3-5/8	4.06
TCP172	9	0.196	2-7/16	3-5/8	4.13
TCP173	8	0.199	2-7/16	3-5/8	4.13
TCP174	7	0.201	2-7/16	3-5/8	4.04
TCP175	6	0.204	2-1/2	3-3/4	4.68
TCP176	5	0.2055	2-1/2	3-3/4	4.68
TCP177	4	0.209	2-1/2	3-3/4	4.68
TCP178	3	0.213	2-1/2	3-3/4	4.63
TCP179	2	0.221	2-5/8	3-7/8	5.13
TCP180	1	0.228	2-5/8	3-7/8	5.09

R15P SERIES - LETTER SIZE

- Bright finish improves chip flow in soft or non-ferrous materials

Model No.	Letter Size	Decimal Size"	L2"	L1"	Price /Each
TC0978	A	0.234	2-5/8	3-7/8	5.78
TC0979	B	0.2374	2-3/4	4	5.78
TC0980	C	0.2421	2-3/4	4	5.78
TC0981	D	0.2461	2-3/4	4	5.78
TC0982	E	0.25	2-3/4	4	5.39
TC0983	F	0.2571	2-7/8	4-1/8	6.16
TC0984	G	0.261	2-7/8	4-1/8	6.93
TC0985	H	0.2661	2-7/8	4-1/8	6.93
TC0986	I	0.272	2-7/8	4-1/8	6.93
TC0987	J	0.2772	2-7/8	4-1/8	7.41
TC0988	K	0.2811	2-15/16	4-1/4	8.21
TC0989	L	0.2902	2-15/16	4-1/4	8.21
TC0990	M	0.2949	3-1/16	4-3/8	8.65
TC0991	N	0.302	3-1/16	4-3/8	8.65
TC0992	O	0.3161	3-3/16	4-1/2	8.76
TC0993	P	0.3228	3-5/16	4-5/8	9.98
TC0994	Q	0.3319	3-7/16	4-3/4	9.98
TC0995	R	0.339	3-7/16	4-3/4	10.60
TC0996	S	0.348	3-1/2	4-7/8	11.30
TC0997	T	0.358	3-1/2	4-7/8	12.80
TC0998	U	0.368	3-5/8	5	12.80
TC0999	V	0.3772	3-5/8	5	13.20
TC000	W	0.3858	3-3/4	5-1/8	13.60
TC001	X	0.3969	3-3/4	5-1/8	16.40
TC002	Y	0.4039	3-7/8	5-1/4	18.50
TC003	Z	0.413	3-7/8	5-1/4	19.70

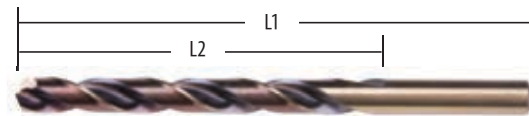

Model No.	Fractional Size"	Decimal Size"	L2"	L1"	Price /Each
TDE119	19/64	0.2969	3-1/16	4-3/8	7.29
TDE120	5/16	0.3125	3-3/16	4-1/2	8.06
TDE121	21/64	0.3281	3-5/16	4-5/8	9.00
TDE122	11/32	0.3437	3-7/16	4-3/4	10.10
TDE123	23/64	0.3594	3-1/2	4-7/8	11.30
TDE124	3/8	0.375	3-5/8	5	11.50
TDE125	25/64	0.3906	3-3/4	5-1/8	13.20
TDE126	13/32	0.4063	3-7/8	5-1/4	13.60
TDE127	27/64	0.4219	3-15/16	5-3/8	15.10
TDE128	7/16	0.4375	4-1/16	5-1/2	15.60
TDE129	29/64	0.4531	4-3/16	5-5/8	17.50
TDE130	15/32	0.4687	4-5/16	5-3/4	18.50
TDE131	31/64	0.4844	4-3/8	5-7/8	19.60
TDE132	1/2	0.5	4-1/2	6	19.70

JOBBER DRILLS 135° (CONT.)

HX18 SERIES - WIRE GAUGE SIZE

Model No.	Wire Gauge Size	Decimal Size"	L2"	L1"	Price /Each
TCP237	52	0.0635	7/8	1-7/8	2.57
TCP238	51	0.067	1	2	2.57
TCP239	50	0.07	1	2	2.57
TCP240	49	0.073	1	2	2.57
TCP241	48	0.076	1	2	2.57
TCP242	47	0.0785	1	2	2.57
TCP243	46	0.081	1-1/8	2-1/8	2.57
TCP244	45	0.082	1-1/8	2-1/8	2.57
TCP245	44	0.086	1-1/8	2-1/8	2.57
TCP246	43	0.089	1-1/4	2-1/4	2.57
TCP247	42	0.0935	1-1/4	2-1/4	2.57
TCP248	41	0.096	1-3/8	2-3/8	2.57
TCP249	40	0.098	1-3/8	2-3/8	2.57
TCP250	39	0.0995	1-3/8	2-3/8	2.57
TCP251	38	0.1015	1-7/16	2-1/2	2.57
TCP252	37	0.104	1-7/16	2-1/2	2.57
TCP253	36	0.1065	1-7/16	2-1/2	2.57
TCP254	35	0.11	1-1/2	2-5/8	2.57
TCP255	34	0.111	1-1/2	2-5/8	2.57
TCP256	33	0.113	1-1/2	2-5/8	2.57
TCP257	32	0.116	1-5/8	2-3/4	2.57
TCP258	31	0.12	1-5/8	2-3/4	2.57
TCP259	30	0.1285	1-5/8	2-3/4	2.61
TCP260	29	0.136	1-3/4	2-7/8	2.61
TCP261	28	0.1405	1-3/4	2-7/8	2.62
TCP262	27	0.144	1-7/8	3	2.84

HX15 SERIES - LETTER SIZE

Model No.	Letter Size	Decimal Size"	L2"	L1"	Price /Each
TCP211	A	0.234	2-5/8	3-7/8	6.16
TCP212	B	0.2374	2-3/4	4	6.16
TCP213	C	0.2421	2-3/4	4	6.16
TCP214	D	0.2461	2-3/4	4	6.16
TDE116	E	0.25	2-3/4	4	5.09
TCP216	F	0.2571	2-7/8	4-1/8	6.51
TCP217	G	0.261	2-7/8	4-1/8	7.36
TCP218	H	0.2661	2-7/8	4-1/8	7.36
TCP219	I	0.272	2-7/8	4-1/8	7.36
TCP220	J	0.2772	2-7/8	4-1/8	7.86
TCP221	K	0.2811	2-15/16	4-1/4	8.68
TCP222	L	0.2902	2-15/16	4-1/4	8.68
TCP223	M	0.2949	3-1/16	4-3/8	9.20

Model No.	Wire Gauge Size	Decimal Size"	L2"	L1"	Price /Each
TCP263	26	0.147	1-7/8	3	2.89
TCP264	25	0.1495	1-7/8	3	2.84
TCP265	24	0.152	2	3-1/8	2.94
TCP266	23	0.154	2	3-1/8	2.94
TCP267	22	0.157	2	3-1/8	3.01
TCP268	21	0.159	2-1/8	3-1/4	2.96
TCP269	20	0.161	2-1/8	3-1/4	3.24
TCP270	19	0.166	2-1/8	3-1/4	3.24
TCP271	18	0.1695	2-1/8	3-1/4	3.26
TCP272	17	0.173	2-3/16	3-3/8	3.94
TCP273	16	0.177	2-3/16	3-3/8	3.94
TCP274	15	0.18	2-3/16	3-3/8	3.94
TCP275	14	0.182	2-3/16	3-3/8	3.94
TCP276	13	0.185	2-5/16	3-1/2	3.94
TCP277	12	0.189	2-5/16	3-1/2	4.04
TCP278	11	0.191	2-5/16	3-1/2	4.01
TCP279	10	0.1935	2-7/16	3-5/8	4.33
TCP280	9	0.196	2-7/16	3-5/8	4.38
TCP281	8	0.199	2-7/16	3-5/8	4.38
TCP282	7	0.201	2-7/16	3-5/8	4.33
TCP283	6	0.204	2-1/2	3-3/4	4.94
TCP284	5	0.2055	2-1/2	3-3/4	4.94
TCP285	4	0.209	2-1/2	3-3/4	4.94
TCP286	3	0.213	2-1/2	3-3/4	4.89
TCP287	2	0.221	2-5/8	3-7/8	5.44
TCP288	1	0.228	2-5/8	3-7/8	5.39

Model No.	Letter Size	Decimal Size"	L2"	L1"	Price /Each
TCP224	N	0.302	3-1/16	4-3/8	9.20
TCP225	O	0.3161	3-3/16	4-1/2	9.31
TCP226	P	0.3228	3-5/16	4-5/8	10.50
TCP227	Q	0.3319	3-7/16	4-3/4	10.50
TCP228	R	0.339	3-7/16	4-3/4	11.30
TCP229	S	0.348	3-1/2	4-7/8	12.00
TCP230	T	0.358	3-1/2	4-7/8	13.60
TCP231	U	0.368	3-5/8	5	13.60
TCP232	V	0.3772	3-5/8	5	14.00
TCP233	W	0.3858	3-3/4	5-1/8	14.40
TCP234	X	0.3969	3-3/4	5-1/8	17.50
TCP235	Y	0.4039	3-7/8	5-1/4	19.70
TCP236	Z	0.413	3-7/8	5-1/4	21.00

JOBBER DRILL SETS

A097 SERIES

- TiN coated tip that increases surface hardness and improves tool life
- Low thrust design with self centering split point that makes for easier penetration
- Material: High Speed Steel
- Manufacturing Standards: ANSI
- Point Angle: 118°
- Cutting Direction: Right Hand
- Case Included

Note: Sizes 47 to 60 and 1/16" to 5/64" have no split point or TiN tip



TCP405

Model No.	No. of Pieces	Sizes	Price /Each
TCP405	29	1/16" to 1/2" by 1/64"	263.00
TCP407	13	1/16" to 1/4" by 1/64"	54.70
TCP408	60	1 to 60	203.00
TCP409	26	A to Z	286.00

JOBBER DRILL SETS

C29HX10 SERIES

- Unique surface treatment for improved wear resistance in hard ferrous alloys
- Low thrust design and self-centering split point makes for easier penetration
- Material: High Speed Steel
- Manufacturing Standards: ANSI
- Point Angle: 135°
- Finish: Purple and Gold
- Cutting Direction: Right Hand
- Case Included



Model No.	No. of Pieces	Sizes	Price /Each
TCP404	29	1/16" to 1/2" by 1/64"	274.00

CUTTING TOOLS

TAP & DRILL SETS

18 PC BLUE WIZARD

- Premium high speed steel
- Metal case



CLARKSON OSBORN

NC (National Coarse) Model No. BG080 contains		NF (National Fine) Model No. BG078 contains		Metric Model No. BG079 contains	
Tap	Drill	Tap	Drill	Tap mm	Drill mm
#6-32	#36	#6-40	#33	2.5 x .45	2.05
#8-32	#29	#8-36	#29	3.0 x .5	2.5
#10-32	#21	#10-32	#21	3.5 x .6	2.9
#12-24	#16	#12-28	#15	4.0 x .7	3.3
1/4-20	#7	1/4-28	#3	5.0 x .8	4.2
5/16-18	F	5/16-24	#1	6.0 x 1	5
3/8-16	5/16	3/8"-24	Q	8.0 x 1.25	6.7
7/16-14	U	7/16	25/64	10.0 x 1.5	8.5
1/2-13	27/64	1/2-20	29/64	12 x 1.75	10
Price/Each \$209.00		Price/Each \$209.00		Price/Each \$245.00	

PIPE TAPS

- High speed steel, ground threads
- Square drive shank
- Right hand cutting direction

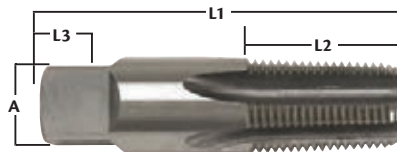

CLARKSON OSBORN

WARWICK NPT (NATIONAL PIPE THREAD) TAPS

Applications:

For tapping tapered pipe threads. This is the most common of all pipe tap styles. The tapered thread form creates a pressure-tight joint when used with a sealant.

Model No.	NPT Size	L2"	L1"	L3"	A"	Flutes	Price /Each
BD944	1/16-27	11/16	2 1/8	3/8	0.234	3	29.90
QD610	1/8-27	3/4	2 1/8	3/8	0.328	3	29.90
QD611	1/4-18	1 1/16	2 7/16	7/16	0.421	5	36.90
QD612	3/8-18	1 1/16	2 9/16	1/2	0.531	5	46.90
BD946	1/2-14	1 3/8	3 1/8	5/8	0.515	5	69.90
BD947	3/4-14	1 3/8	3 1/4	11/16	0.679	5	105.00
BD948	1-11.5	1 3/4	3 3/4	13/16	0.843	5	155.00
BD949	1 1/4-11.5	1 3/4	4	15/16	0.984	7	245.00
BD950	1 1/2-11.5	1 3/4	4 1/4	1	1.125	7	295.00
BD951	2-11.5	1 3/4	4 1/2	1 1/8	1.406	7	369.00

WARWICK NPTF (DRYSEAL NATIONAL PIPE THREAD) TAPS

HSS taper pipe taps are designed for tapping ferrous and non-ferrous fittings used to connect pipes carrying fluids or gases and other places where very tight fits are needed. NPTF taper thread pipe taps do not require sealants. Dryseal is attained by metal to metal contact.

Model No.	NPT Size	L2"	L1"	L3"	A"	Flutes	Price /Each
BD961	1/16-27	11/16	2 1/8	3/8	0.234	3	73.50
BD962	1/8-27	3/4	2 1/8	3/8	0.328	3	72.50
BD963	1/4-18	1 1/16	2 7/16	7/16	0.421	5	77.50
BD964	3/8-18	1 1/16	2 9/16	1/2	0.531	5	115.00
BD965	1/2-14	1 3/8	3 1/8	5/8	0.515	5	135.00
BD966	3/4-14	1 3/8	3 1/4	11/16	0.679	5	169.00
BD967	1-11.5	1 3/4	3 3/4	13/16	0.843	5	295.00
BD968	1 1/4-11.5	1 3/4	4	15/16	0.984	7	459.00

WARWICK NPTI (INTERRUPTED NATIONAL PIPE THREAD) TAPS

Application:

HSS interrupted thread pipe taps are designed for tapping soft or tough stringy metals that tend to load threads with chips. Interrupted thread pipe taps start with a few full threads and then have every other thread removed along the thread helix to provide more chip space, better lubrication, and to reduce drag.

Model No.	NPT Size	L2"	L1"	L3"	A"	Flutes	Price /Each
BD952	1/8-27	3/4	2 1/8	3/8	0.328	3	66.90
BD953	1/4-18	1 1/16	2 7/16	7/16	0.421	5	73.50
BD954	3/8-18	1 1/16	2 9/16	1/2	0.531	5	93.50
BD955	1/2-14	1 3/8	3 1/8	5/8	0.515	5	149.00
BD956	3/4-14	1 3/8	3 1/4	11/16	0.679	5	165.00
BD957	1-11.5	1 3/4	3 3/4	13/16	0.843	5	325.00
BD958	1 1/4-11.5	1 3/4	4	15/16	0.984	7	435.00
BD959	1 1/2-11.5	1 3/4	4 1/4	1	1.125	7	535.00
BD960	2-11.5	1 3/4	4 1/2	1 1/8	1.406	7	795.00

WARWICK NPTS (STRAIGHT NATIONAL PIPE THREAD) TAPS

Application:

HSS straight thread pipe taps (NPTS) are designed for tapping holes or couplings for low pressure work that will adjust at assembly to the taper of external threads. A sealant must be used to secure a pressure-tight joint.

Model No.	NPT Size	L2"	L1"	L3"	A"	Flutes	Price /Each
BD969	1/8-27	3/4	2 1/8	3/8	0.328	4	47.50
BD970	1/4-18	1 1/16	2 7/16	7/16	0.421	4	65.90
BD971	3/8-18	1 1/16	2 9/16	1/2	0.531	4	105.00
BD972	1/2-14	1 3/8	3 1/8	5/8	0.515	4	139.00
BD973	3/4-14	1 3/8	3 1/4	11/16	0.679	4	195.00
BD974	1-11.5	1 3/4	3 3/4	13/16	0.843	6	365.00

HAND TAPS

- High speed steel ground thread
- Square drive shank
- Right hand cutting direction, straight flute
- Available in taper, plug, bottoming and sets
- Bright finish

Applications:

Taps cut a thread on the inside surface of a hole, creating a female surface which functions like a nut. Well suited for a variety of ferrous & non-ferrous materials.

Taper

Used in through-holes and for starting threads.

Used in through-holes and in blind holes with space at the bottom for chip accumulation.

Used in blind holes where threads must come as close to the hole's bottom as possible

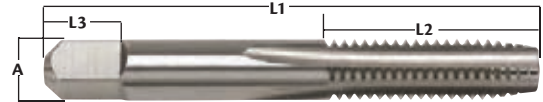

Plug

Bottoming

MACHINE SCREW SIZES - NC NATIONAL COARSE
NF NATIONAL FINE

Fractional Size	Taper Model No.	Plug Model No.	Bottoming Model No.	Price /Each	L2"	L1"	L3"	A"	Flutes	Set of 3 taps		
										Model No.	Price /Each	
0-80	NF	BL964	BL965	BL966	26.50	3/8	1 5/8	3/16	0.110	3	BL963	79.50
1-64	NC	BL968	BL969	BL970	25.90	7/16	1 11/16	3/16	0.110	2	BL967	76.90
1-72	NF	BM005	BM006	BM007	25.90	7/16	1 11/16	3/16	0.110	3	BM004	76.90
2-56	NC	BL972	BL973	BL974	21.90	1/2	1 3/4	3/16	0.110	3	BL971	65.50
2-64	NF	BM009	BM010	BM011	21.90	1/2	1 3/4	3/16	0.110	3	BM008	65.50
3-48	NC	BL976	BL977	BL978	16.50	9/16	1 13/16	3/16	0.110	3	BL975	48.50
3-56	NF	BM013	BM014	BM015	16.50	9/16	1 13/16	3/16	0.110	3	BM012	48.50
4-40	NC	BL980	BL981	BL982	13.50	5/8	1 7/8	3/16	0.110	3	BL979	39.90
4-48	NF	BM017	BM018	BM019	13.50	5/8	1 7/8	3/16	0.110	3	BM016	39.90
5-40	NC	BL984	BL985	BL986	13.50	11/16	1 15/16	3/16	0.110	3	BL983	39.90
5-44	NF	BM021	BM022	BM023	13.50	11/16	1 15/16	3/16	0.110	3	BM020	39.90
6-32	NC	BL988	BL989	BL990	10.50	11/16	2	3/16	0.110	3	BL987	30.50
6-40	NF	BM025	BM026	BM027	10.50	11/16	2	3/16	0.110	3	BM024	30.50
8-32	NC	BL992	BL993	BL994	10.50	3/4	2 1/8	1/4	0.131	4	BL991	30.50
8-36	NF	BM029	BM030	BM031	10.50	3/4	2 1/8	1/4	0.131	4	BM028	30.50
10-24	NC	BL996	BL997	BL998	10.90	7/8	2 3/8	1/4	0.152	4	BL995	32.90
10-32	NF	BM033	BM034	BM035	10.90	7/8	2 3/8	1/4	0.152	4	BM032	32.90
12-24	NC	BM001	BM002	BM003	11.50	15/16	2 3/8	9/32	0.165	4	BL999	33.90
12-28	NF	BM037	BM038	BM039	11.50	15/16	2 3/8	9/32	0.165	4	BM036	33.90

FRACTIONAL SIZES - NC NATIONAL COARSE
NF NATIONAL FINE

Fractional Size	Taper Model No.	Plug Model No.	Bottoming Model No.	Price /Each	L2"	L1"	L3"	A"	Flutes	Set of all 3 taps		
										Model No.	Price /Each	
1/4-20	NC	BL843	BL844	BL845	10.90	1	2 1/2	5/16	0.191	4	BL842	32.50
1/4-28	NF	BL905	BL906	BL907	10.90	1	2 1/2	5/16	0.191	4	BL904	32.50
5/16-18	NC	BL847	BL848	BL849	13.50	1 1/8	2 23/32	3/8	0.238	4	QE252	40.50
5/16-24	NF	BL909	BL910	BL911	13.50	1 1/8	2 23/32	3/8	0.238	4	BL908	40.50
3/8-16	NC	BL851	BL852	BL853	15.50	1 1/4	2 15/16	7/16	0.286	4	BL850	45.50
3/8-24	NF	BL912	BL913	BL914	15.50	1 1/4	2 15/16	7/16	0.286	4	VE890	45.50
7/16-14	NC	BL855	BL856	BL857	25.90	1 7/16	3 5/32	13/32	0.242	4	BL854	78.50
7/16-20	NF	BL916	BL917	BL918	25.90	1 7/16	3 5/32	13/32	0.242	4	BL915	78.50
1/2-13	NC	BL859	BL860	BL861	26.90	1 21/32	3 3/8	7/16	0.275	4	BL858	80.90
1/2-20	NF	BL920	BL921	BL922	26.90	1 21/32	3 3/8	7/16	0.275	4	BL919	80.90
9/16-12	NC	BL863	BL864	BL865	44.90	1 21/32	3 19/32	1/2	0.322	4	BL862	139.00
9/16-18	NF	BL924	BL925	BL926	44.90	1 21/32	3 19/32	1/2	0.322	4	BL923	139.00
5/8-11	NC	QE253	BL867	BL868	54.90	1 13/16	3 13/16	9/16	0.360	4	BL866	165.00
5/8-18	NF	BL928	BL929	BL930	54.90	1 13/16	3 13/16	9/16	0.360	4	BL927	165.00
3/4-10	NC	VE860	BL870	BL871	75.90	2	4 1/4	11/16	0.442	4	BL869	229.00
3/4-16	NF	BL932	BL933	BL934	75.90	2	4 1/4	11/16	0.442	4	BL931	229.00
7/8-9	NC	BL873	BL874	BL875	125.00	2 7/32	4 11/16	3/4	0.523	4	BL872	369.00
7/8-14	NF	BL936	BL937	BL938	119.00	2 7/32	4 11/16	3/4	0.523	4	BL935	359.00
1-8	NC	BL877	BL878	BL879	145.00	2 1/2	5 1/8	13/16	0.600	4	BL876	425.00
1-12	NF	BL940	BL941	BL942	165.00	2 1/2	5 1/8	13/16	0.600	4	BL939	489.00
1-14	NS	BL960	BL961	BL962	145.00	2 1/2	5 1/8	13/16	0.600	4	BL959	425.00
1 1/8-7	NC	QE254	BL882	BL883	185.00	2 9/16	5 7/16	7/8	0.672	4	BL880	549.00
1 1/8-12	NF	BL944	BL945	BL946	209.00	2 9/16	5 7/16	7/8	0.672	4	BL943	619.00
1 1/4-7	NC	BL885	BL886	BL887	245.00	2 9/16	5 3/4	1	0.766	4	BL884	729.00
1 1/4-12	NF	BL948	BL949	BL950	245.00	2 9/16	5 3/4	1	0.766	4	BL947	729.00
1 3/8-6	NC	BL889	BL890	BL891	305.00	3	6 1/16	1 1/16	0.831	4	BL888	915.00
1 3/8-12	NF	BL952	BL953	BL954	305.00	3	6 1/16	1 1/16	0.831	4	BL951	915.00
1 1/2-6	NC	BL893	BL894	BL895	355.00	3	6 3/8	1 1/8	0.925	4	BL892	1055.00
1 1/2-12	NE	BL956	BL957	BL958	355.00	3	6 3/8	1 1/8	0.925	4	BL955	1055.00
1 3/4-5	NC	BL897	BL898	BL899	519.00	3 3/16	7	1 1/4	1.072	6	BL896	1555.00
2-4.5	NC	BL901	BL902	BL903	575.00	3 9/16	7 5/8	1 3/8	1.233	6	BL900	1725.00

CUTTING TOOLS

HAND TAPS (CONT'D)

METRIC COARSE SIZES

Size	Taper Model No.	Plug Model No.	Bottoming Model No.	Price /Each	L2 mm	L1 mm	L3 mm	A mm	Flutes	Set of 3 taps	
										Model No.	Price /Each
M2 x 0.4	BM185	BM186	BM187	23.50	8.0	41.0	4.0	2.00	3	BM184	70.50
M2.2 x 0.45	BM182	BM183	TBM075	24.50	9.5	44.5	5.0	2.24	3	BM181	72.90
M2.5 x 0.45	BM189	BM190	BM191	16.90	9.5	44.5	5.0	2.24	3	BM188	50.90
M3 x 0.5	BM193	BM194	BM195	13.90	15.0	48.0	5.0	2.50	3	BM192	41.50
M3.5 x 0.6	BM197	BM198	BM199	10.90	17.0	50.0	5.0	2.80	3	BM196	32.90
M4 x 0.7	BM201	BM202	BM203	10.90	17.0	53.0	6.0	3.15	3	BM200	32.90
M4.5 x 0.75	BM205	BM206	BM207	15.50	17.0	53.0	6.0	3.55	3	BM204	45.90
M5 x 0.8	BM209	BM210	BM211	12.50	16.0	58.0	7.0	4.00	3	BM208	35.90
M6 x 1	BM213	BM214	BM215	12.50	19.0	66.0	8.0	5.00	3	BM212	37.50
M7 x 1	BM217	BM218	BM219	13.50	19.0	66.0	8.0	5.60	4	BM216	39.90
M8 x 1.25	BM221	BM222	BM223	13.50	22.0	72.0	9.0	6.30	4	BM220	39.90
M9 x 1.25	BM225	BM226	BM227	16.90	22.0	72.0	10.0	7.10	4	BM224	49.90
M10 x 1.5	BM229	BM230	BM231	24.90	24.0	80.0	11.0	8.00	4	BM228	74.90
M11 x 1.5	BM233	BM234	BM235	24.90	25.0	85.0	9.0	6.30	4	BM232	74.90
M12 x 1.75	BM237	BM238	BM239	28.50	19.0	89.0	10.0	7.10	4	BM236	84.90
M14 x 2	BM241	BM242	BM243	43.50	30.0	95.0	12.0	9.00	4	BM240	135.00
M16 x 2	BM245	BM246	BM247	53.50	32.0	102.0	13.0	10.00	4	BM244	165.00
M18 x 2.5	BM249	BM250	BM251	73.50	37.0	112.0	14.0	11.20	4	BM248	225.00
M20 x 2.5	BM253	BM254	BM255	105.00	37.0	112.0	14.0	11.20	4	BM252	305.00
M22 x 2.5	BM257	BM258	BM259	119.00	38.0	118.0	16.0	12.50	4	BM256	355.00
M24 x 3	BM261	BM262	BM263	139.00	45.0	130.0	18.0	14.00	4	BM260	405.00
M27 x 3	BM265	BM266	BM267	185.00	45.0	135.0	20.0	16.00	4	BM264	545.00
M30 x 3.5	BM269	BM270	BM271	199.00	48.0	138.0	20.0	16.00	4	BM268	589.00
M33 x 3.5	BM273	BM274	BM275	265.00	51.0	151.0	22.0	18.00	4	BM272	795.00
M36 x 4	BM277	BM278	BM279	295.00	57.0	162.0	24.0	20.00	4	BM276	879.00
M39 x 4	BM280	BM281	BM282	355.00	60.0	170.0	26.0	22.40	4	TBM083	1065.00
M42 x 4.5	BM284	BM285	BM286	415.00	60.0	170.0	26.0	22.40	6	BM283	1239.00
M45 x 4.5	TBM067	BM287	BM288	555.00	67.0	187.0	28.0	25.00	6	TBM084	1665.00
M48 x 5	TBM068	BM289	BM290	619.00	67.0	187.0	28.0	25.00	6	TBM085	1855.00
M52 x 5	TBM069	BM291	BM292	779.00	70.0	200.0	31.0	28.00	6	TBM086	2329.00
M56 x 5.5	TBM070	BM293	BM294	1055.00	70.0	200.0	31.0	28.00	6	TBM087	3159.00

METRIC FINE SIZES

Size	Taper Model No.	Plug Model No.	Bottoming Model No.	Price /Each	L2 mm	L1 mm	L3 mm	A mm	Flutes	Set of 3 taps	
										Model No.	Price/Each
MF3 x 0.35	BM296	BM297	BM298	28.50	15.0	48.0	5.0	2.50	3	BM295	85.50
MF3.5 x 0.35	BM299	BM300	BM301	29.90	17.0	50.0	5.0	2.80	3	TBM088	89.50
MF4 x 0.5	BM303	BM304	BM305	28.50	17.0	53.0	6.0	3.15	3	BM302	85.90
MF4.5 x 0.5	BM307	BM308	BM309	31.90	17.0	53.0	6.0	3.55	3	BM306	95.50
MF5 x 0.5	BM311	BM312	BM313	28.50	16.0	58.0	7.0	4.00	3	BM310	85.90
MF6 x 0.5	BM315	BM316	BM317	69.90	19.0	66.0	8.0	5.00	3	BM314	209.00
MF6 x 0.75	BM319	BM320	BM321	28.50	19.0	66.0	8.0	5.00	3	BM318	85.90
MF7 x 0.75	BM323	BM324	BM325	31.90	19.0	66.0	8.0	5.60	4	BM322	95.50
MF8 x 0.5	BM328	BM329	BM330	75.90	19.0	69.0	9.0	6.30	4	BM327	229.00
MF8 x 0.75	BM332	BM333	BM334	34.90	22.0	72.0	9.0	6.30	4	BM331	109.00
MF8 x 1	BM335	BM336	BM337	29.90	22.0	72.0	9.0	6.30	4	BM326	89.50
MF9 x 1	BM338	BM339	BM340	69.90	22.0	72.0	10.0	7.10	4	BM341	209.00
MF10 x 0.75	BM345	BM346	BM347	69.90	24.0	80.0	11.0	8.00	4	BM344	209.00
MF10 x 1	BM348	BM349	BM350	43.50	24.0	80.0	11.0	8.00	4	BM342	135.00
MF10 x 1.25	BM351	BM352	BM353	41.90	24.0	80.0	11.0	8.00	4	BM343	125.00
MF11 x 0.75	BM355	BM356	BM357	85.90	22.0	82.0	9.0	6.30	4	BM354	259.00
MF11 x 1	BM359	BM360	BM361	85.90	22.0	82.0	9.0	6.30	4	BM358	259.00
MF12 x 1	BM363	BM364	BM365	83.50	29.0	89.0	10.0	7.10	4	BM362	255.00
MF12 x 1.25	BM367	BM368	BM369	54.90	29.0	89.0	10.0	7.10	4	BM366	165.00
MF12 x 1.5	BM371	BM372	BM373	54.90	29.0	89.0	10.0	7.10	4	BM370	165.00
MF14 x 1	BM375	BM376	BM377	92.50	30.0	95.0	12.0	9.00	4	BM374	279.00
MF14 x 1.25	BM379	BM380	BM381	62.50	30.0	95.0	12.0	9.00	4	BM378	189.00
MF14 x 1.5	BM383	BM384	BM385	60.50	30.0	95.0	12.0	9.00	4	BM382	185.00
MF16 x 1	BM387	BM388	BM389	105.00	32.0	102.0	13.0	10.00	4	BM386	305.00
MF16 x 1.5	BM391	BM392	BM393	67.90	32.0	102.0	13.0	10.00	4	BM390	205.00
MF18.0 x 1	BM395	BM396	BM397	129.00	37.0	112.0	14.0	11.20	4	BM394	389.00
MF18 x 1.5	BM399	BM400	BM401	93.90	37.0	112.0	14.0	11.20	4	BM398	285.00
MF18 x 2	BM403	BM404	BM405	129.00	37.0	112.0	14.0	11.20	4	BM402	389.00
MF20 x 1	BM407	BM408	BM409	149.00	37.0	112.0	14.0	11.20	4	BM406	445.00
MF20 x 1.5	BM411	BM412	BM413	115.00	37.0	112.0	14.0	11.20	4	BM410	345.00
MF20 x 2	BM415	BM416	BM417	149.00	37.0	112.0	14.0	11.20	4	BM414	445.00
MF22 x 1.5	BM419	BM420	BM421	129.00	38.0	118.0	16.0	12.50	4	BM418	389.00
MF22 x 2	BM423	BM424	BM425	145.00	38.0	118.0	16.0	12.50	4	BM422	429.00
MF24 x 1.5	BM427	BM428	BM429	189.00	45.0	130.0	18.0	14.00	4	BM426	559.00
MF24 x 2	BM431	BM432	BM433	165.00	45.0	130.0	18.0	14.00	4	BM430	485.00
MF25 x 1.5	BM435	BM436	BM437	155.00	35.0	120.0	18.0	14.00	4	BM434	465.00
MF27 x 2	BM439	BM440	BM441	239.00	37.0	127.0	20.0	16.00	4	BM438	715.00
MF30 x 1.5	BM443	BM444	BM445	309.00	37.0	127.0	20.0	16.00	4	BM442	925.00
MF30 x 2	BM447	BM448	BM449	265.00	37.0	127.0	20.0	16.00	4	BM446	795.00
MF32 x 1.5	TBM076	BM451	TBM079	309.00	37.0	137.0	22.0	18.00	4	BM450	925.00
MF40 x 1.5	TBM077	TBM078	TBM080	489.00	39.0	149.0	26.0	22.40	4	TBM089	1465.00

HAND TAPS

- Versatile tap that can be used for both hand or machine tapping in a wide variety of materials
- Bright finish improves chip flow in soft or non-ferrous materials
- Material: High Speed Steel
- Manufacturing Standards: ANSI
- Cutting Direction: Right Hand
- **1500-1500S series:** Fractional sizes
- **1528-1528S series:** Machine screw sizes

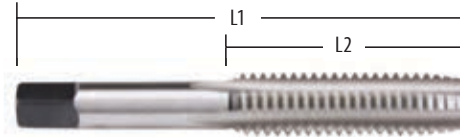

Note: Sizes 0-80 through 3/8"-24 have a male centre on the thread end
 Sizes 7/16"-14 through 1-1/2"-12 have a female centre/flat end

UNION BUTTERFIELD®

0-80	Unified Fine	2	5/16	1-5/8	H1	TCQ219	TCQ277	TCQ361	23.50	TCQ441	70.10
0-80	Unified Fine	2	5/16	1-5/8	H2	-	TCQ278	TCQ362	23.50	-	-
1-64	Unified Coarse	2	3/8	1-11/16	H1	TCQ220	TCQ279	TCQ363	21.90	TCQ442	65.40
1-72	Unified Fine	2	3/8	1-11/16	H1	TCQ221	TCQ280	TCQ364	21.90	TCQ443	65.40
2-56	Unified Coarse	2	7/16	1-3/4	H2	-	TCQ281	TCQ365	20.50	-	-
2-56	Unified Coarse	3	7/16	1-3/4	H1	TCQ222	TCQ282	TCQ366	20.50	-	-
2-56	Unified Coarse	3	7/16	1-3/4	H2	TCQ223	TCQ283	TCQ367	19.20	TCQ444	57.70
2-64	Unified Fine	3	7/16	1-3/4	H2	-	-	-	-	TCQ445	61.40
3-48	Unified Coarse	2	1/2	1-13/16	H2	-	TCQ284	-	16.30	-	-
3-48	Unified Coarse	3	1/2	1-13/16	H2	TCQ224	TCQ285	TCQ368	14.50	TCQ446	43.30
3-56	Unified Fine	3	1/2	1-13/16	H2	TCQ225	TCQ286	TCQ369	16.30	TCQ447	48.70
4-40	Unified Coarse	2	9/16	1-7/8	H2	-	TCQ287	TCQ370	12.90	-	-
4-40	Unified Coarse	3	9/16	1-7/8	H1	TCQ226	TCQ288	TCQ371	12.90	-	-
4-40	Unified Coarse	3	9/16	1-7/8	H2	TCQ227	TCQ289	TCQ372	12.00	TCQ448	35.90
4-48	Unified Fine	3	9/16	1-7/8	H2	TCQ228	TCQ290	TCQ373	12.90	TCQ449	38.50
4-36	Unified Special	3	9/16	1-7/8	H2	-	-	-	-	TCQ450	34.50
5-40	Unified Coarse	3	5/8	1-15/16	H2	TCQ229	TCQ291	TCQ374	12.00	TCQ451	35.90
5-44	Unified Fine	3	5/8	1-15/16	H2	TCQ230	TCQ292	TCQ375	12.90	TCQ452	38.50
6-32	Unified Coarse	2	11/16	2	H2	-	TCQ293	TCQ376	11.20	-	-
6-32	Unified Coarse	2	11/16	2	H3	-	TCQ294	TCQ377	9.63	-	-
6-32	Unified Coarse	3	11/16	2	H1	TCQ231	TCQ295	TCQ378	11.20	-	-
6-32	Unified Coarse	3	11/16	2	H2	TCQ232	TCQ296	-	9.63	-	-
6-32	Unified Coarse	3	11/16	2	H3	TCQ233	TCQ297	TCQ380	9.11	TCQ454	27.50
6-40	Unified Fine	3	11/16	2	H2	TCQ234	TCQ298	TCQ381	9.63	TCQ455	28.90
8-32	Unified Coarse	2	3/4	2-1/8	H2	-	TCQ299	TCQ382	11.20	-	-
8-32	Unified Coarse	2	3/4	2-1/8	H3	-	TCQ300	TCQ383	9.63	-	-
8-32	Unified Coarse	3	3/4	2-1/8	H2	-	TCQ301	TCQ384	11.20	-	-
8-32	Unified Coarse	3	3/4	2-1/8	H3	-	TCQ302	TCQ385	9.63	-	-
8-32	Unified Coarse	4	3/4	2-1/8	H1	-	TCQ303	-	11.20	-	-
8-32	Unified Coarse	4	3/4	2-1/8	H2	TCQ235	TCQ304	TCQ386	9.63	TCQ456	28.90
8-32	Unified Coarse	4	3/4	2-1/8	H3	TCQ236	TCQ305	TCQ387	9.35	TCQ457	28.10
8-36	Unified Fine	4	3/4	2-1/8	H2	TCQ237	TCQ306	TCQ388	9.63	TCQ458	28.90
10-24	Unified Coarse	2	7/8	2-3/8	H2	-	TCQ307	TCQ389	11.20	-	-
10-24	Unified Coarse	2	7/8	2-3/8	H3	-	TCQ308	TCQ390	9.90	-	-
10-24	Unified Coarse	3	7/8	2-3/8	H2	-	TCQ309	-	11.20	-	-
10-24	Unified Coarse	3	7/8	2-3/8	H3	-	TCQ310	TCQ391	9.90	-	-
10-24	Unified Coarse	4	7/8	2-3/8	H1	-	TCQ311	-	9.90	-	-
10-24	Unified Coarse	4	7/8	2-3/8	H2	TCQ238	TCQ312	TCQ392	9.90	TCQ459	29.70
10-24	Unified Coarse	4	7/8	2-3/8	H3	TCQ239	TCQ313	TCQ393	9.90	TCQ460	29.70
10-32	Unified Fine	2	7/8	2-3/8	H2	-	TCQ314	TCQ394	11.20	-	-
10-32	Unified Fine	2	7/8	2-3/8	H3	-	TCQ315	TCQ395	9.90	-	-
10-32	Unified Fine	3	7/8	2-3/8	H2	-	TCQ316	TCQ396	11.20	-	-
10-32	Unified Fine	3	7/8	2-3/8	H3	-	TCQ317	TCQ397	9.90	-	-
10-32	Unified Fine	4	7/8	2-3/8	H2	TCQ240	TCQ318	TCQ398	9.90	TCQ461	29.70
10-32	Unified Fine	4	7/8	2-3/8	H3	TCQ241	TCQ319	TCQ399	9.90	TCQ462	29.70
12-24	Unified Coarse	4	15/16	2-3/8	H3	TCQ242	TCQ320	TCQ400	10.30	TCQ463	30.50
12-28	Unified Fine	4	15/16	2-3/8	H3	TCQ243	TCQ321	TCQ401	11.20	TCQ464	33.80
1/4"-20	Unified Coarse	4	1	2-1/2	H1	TCQ244	TCQ322	TCQ402	13.00	-	-
1/4"-20	Unified Coarse	4	1	2-1/2	H2	TCQ245	TCQ323	TCQ403	12.40	-	-
1/4"-20	Unified Coarse	4	1	2-1/2	H3	TCQ246	TCQ324	TCQ404	10.50	TCQ465	31.30
1/4"-20	Unified Coarse	4	1	2-1/2	H5	-	TCQ325	TCQ405	12.40	-	-
1/4"-28	Unified Fine	4	1	2-1/2	H2	-	TCQ326	TCQ406	13.00	-	-
1/4"-28	Unified Fine	4	1	2-1/2	H3	TCQ247	TCQ327	TCQ407	10.50	TCQ466	31.30
1/4"-28	Unified Fine	4	1	2-1/2	H5	-	TCQ328	TCQ408	13.00	-	-
5/16"-18	Unified Coarse	4	1-1/8	2-23/32	H2	TCQ248	TCQ329	TCQ409	14.30	-	-
5/16"-18	Unified Coarse	4	1-1/8	2-23/32	H3	TCQ249	TCQ330	TCQ410	12.70	TCQ467	37.80
5/16"-24	Unified Fine	4	1-1/8	2-23/32	H3	TCQ250	TCQ331	TCQ411	12.70	TCQ468	37.80
3/8"-16	Unified Coarse	4	1-1/4	2-15/16	H2	TCQ251	TCQ332	TCQ412	16.30	-	-
3/8"-16	Unified Coarse	4	1-1/4	2-15/16	H3	TCQ252	TCQ333	TCQ413	14.30	TCQ469	43.00
3/8"-24	Unified Fine	4	1-1/4	2-15/16	H3	TCQ253	TCQ335	TCQ415	14.30	TCQ470	43.00
7/16"-14	Unified Coarse	4	1-7/16	3-5/32	H3	TCQ254	TCQ336	TCQ416	24.70	TCQ471	74.20
7/16"-20	Unified Fine	4	1-7/16	3-5/32	H3	TCQ255	TCQ337	TCQ417	24.70	TCQ472	74.20
1/2"-13	Unified Coarse	4	1-21/32	3-3/8	H2	-	TCQ338	TCQ418	32.00	-	-
1/2"-13	Unified Coarse	4	1-21/32	3-3/8	H3	TCQ256	TCQ339	TCQ419	25.70	TCQ473	77.10
1/2"-13	Unified Coarse	4	1-21/32	3-3/8	H5	-	TCQ340	TCQ420	32.00	-	-
1/2"-20	Unified Fine	4	1-21/32	3-3/8	H3	TCQ257	TCQ341	TCQ421	29.60	TCQ474	88.20
9/16"-12	Unified Coarse	4	1-21/32	3-19/32	H3	TCQ258	TCQ342	TCQ422	43.50	TCQ475	131.00

CUTTING TOOLS

HAND TAPS (CONT.)

Thread Size	Thread Form	No. of Flutes	L2"	L1"	Limits	Taper Model No.	Plug Model No.	Bottoming Model No.	Price /Each	Sets	Price /Each
9/16"-18	Unified Fine	4	1-21/32	3-19/32	H3	TCQ259	TCQ343	TCQ423	43.50	TCQ476	131.00
5/8"-11	Unified Coarse	4	1-13/16	3-13/16	H3	TCQ260	TCQ344	TCQ424	52.40	TCQ477	158.00
5/8"-18	Unified Fine	4	1-13/16	3-13/16	H3	TCQ261	TCQ345	TCQ425	52.40	TCQ478	158.00
3/4"-10	Unified Coarse	4	2	4-1/4	H3	TCQ262	TCQ346	TCQ426	74.20	TCQ481	222.00
3/4"-16	Unified Fine	4	2	4-1/4	H3	TCQ263	TCQ347	TCQ427	74.20	TCQ482	222.00
7/8"-9	Unified Coarse	4	2-7/32	4-11/16	H4	TCQ264	TCQ348	TCQ428	102.00	TCQ483	306.00
7/8"-14	Unified Fine	4	2-7/32	4-11/16	H4	TCQ265	TCQ349	TCQ429	102.00	TCQ484	306.00
1"-8	Unified Coarse	4	2-1/2	5-1/8	H4	TCQ266	TCQ350	TCQ430	137.00	TCQ485	408.00
1"-12	Unified Fine	4	2-1/2	5-1/8	H4	TCQ267	TCQ351	TCQ431	138.00	TCQ486	413.00
1"-14	Unified Special	4	2-1/2	5-1/8	H4	TCQ268	TCQ352	TCQ432	137.00	TCQ487	375.00
1-1/8"-7	Unified Coarse	4	2-9/16	5-7/16	H4	TCQ269	TCQ353	TCQ433	218.00	TCQ488	652.00
1-1/8"-12	Unified Fine	4	2-9/16	5-7/16	H4	TCQ270	TCQ354	TCQ434	236.00	TCQ489	705.00
1-1/4"-7	Unified Coarse	4	2-9/16	5-3/4	H4	TCQ271	TCQ355	TCQ435	287.00	TCQ490	860.00
1-1/4"-12	Unified Fine	6	2-9/16	5-3/4	H4	TCQ272	TCQ356	TCQ436	293.00	TCQ491	874.00
1-3/8"-6	Unified Coarse	4	3	6-1/16	H4	TCQ273	TCQ357	TCQ437	362.00	TCQ492	1083.00
1-3/8"-12	Unified Fine	6	3	6-1/16	H4	TCQ274	TCQ358	TCQ438	367.00	TCQ493	1096.00
1-1/2"-6	Unified Coarse	4	3	6-3/8	H4	TCQ275	TCQ359	TCQ439	419.00	TCQ494	1254.00
1-1/2"-12	Unified Fine	6	3	6-3/8	H4	TCQ276	TCQ360	TCQ440	426.00	TCQ495	1278.00

HAND TAPS

E500 SERIES

- Versatile tap that can be used for both hand or machine tapping in a wide variety of materials
- Bright finish improves chip flow in soft or non-ferrous materials
- Material: High Speed Steel
- Manufacturing Standards: ISO 529
- Tolerance: 6H
- Cutting Direction: Right Hand



Note: ISO shank and square dimensions require metric holders

Thread Size	Thread Form	No. of Flutes	L2 mm	L1 mm	Taper Model No.	Plug Model No.	Bottoming Model No.	Price /Each	Sets	Price /Each
M1 x 0.25	Metric Coarse	2	4.5	38	TCQ069	TCQ111	TCQ153	104.00	-	-
M1.2 x 0.25	Metric Coarse	2	4.5	38	TCQ070	TCQ112	TCQ154	88.30	-	-
M1.4 x 0.3	Metric Coarse	2	6	40	TCQ071	TCQ113	TCQ155	69.20	-	-
M1.6 x 0.35	Metric Coarse	2	8	41	TCQ072	TCQ114	TCQ156	39.70	TCQ197	120.00
M1.7 x 0.35	Metric Coarse	2	8	41	TCQ073	TCQ115	TCQ157	47.30	TCQ198	142.00
M1.8 x 0.35	Metric Coarse	2	8	41	TCQ074	TCQ116	TCQ158	46.80	-	-
M2 x 0.4	Metric Coarse	3	8	41	TCQ078	TCQ120	TCQ162	30.40	TCQ202	91.40
M2 x 0.45	Metric Coarse	3	8	41	TCQ079	TCQ121	TCQ163	79.70	-	-
M2.2 x 0.45	Metric Coarse	3	9.5	44.5	TCQ080	TCQ122	TCQ164	39.20	-	-
M2.3 x 0.45	Metric Coarse	3	9.5	44.5	TCQ081	TCQ123	TCQ165	36.50	-	-
M2.5 x 0.45	Metric Coarse	3	9.5	44.5	TCQ082	TCQ124	TCQ166	29.60	TCQ203	87.70
M2.6 x 0.45	Metric Coarse	3	9.5	44.5	TCQ083	TCQ125	TCQ167	38.70	-	-
M3 x 0.5	Metric Coarse	3	12.5	48	TCQ084	TCQ126	TCQ168	14.30	TCQ204	42.60
M3 x 0.6	Metric Coarse	3	12.5	48	TCQ085	TCQ127	TCQ169	27.10	-	-
M3.5 x 0.6	Metric Coarse	3	14	50	TCQ086	TCQ128	TCQ170	12.90	TCQ205	38.70
M4 x 0.7	Metric Coarse	3	14	53	TCQ087	TCQ129	TCQ171	12.90	TCQ206	38.70
M4 x 0.75	Metric Coarse	3	14	53	TCQ088	TCQ130	TCQ172	26.50	-	-
M4.5 x 0.75	Metric Coarse	3	9.5	53	TCQ089	TCQ131	TCQ173	12.90	TCQ207	38.70
M5 x 0.8	Metric Coarse	3	11	58	TCQ090	TCQ132	TCQ174	12.90	TCQ208	38.70
M5 x 0.9	Metric Coarse	3	11	58	TCQ091	TCQ133	TCQ175	28.40	-	-
M5.5 x 0.9	Metric Coarse	3	12	62	TCQ092	TCQ134	TCQ176	13.90	-	-
M6 x 1	Metric Coarse	3	13	66	TCQ093	TCQ135	TCQ177	13.70	TCQ209	41.00
M7 x 1	Metric Coarse	3	13	66	TCQ094	TCQ136	TCQ178	15.00	TCQ210	44.50
M8 x 1.25	Metric Coarse	3	16	72	TCQ095	TCQ137	TCQ179	15.00	TCQ211	44.50
M9 x 1.25	Metric Coarse	3	16	72	TCQ096	TCQ138	TCQ180	19.30	TCQ212	57.90
M10 x 1.5	Metric Coarse	3	18	80	TCQ075	TCQ117	TCQ159	28.00	TCQ199	84.00
M11 x 1.5	Metric Coarse	3	19	85	TCQ076	TCQ118	TCQ160	28.00	TCQ200	84.00
M12 x 1.75	Metric Coarse	3	22	89	TCQ077	TCQ119	TCQ161	32.90	TCQ201	98.20
M14 x 2	Metric Coarse	4	24	95	TCQ097	TCQ139	TCQ181	49.00	TCQ213	148.00
M16 x 2	Metric Coarse	4	24	102	TCQ098	TCQ140	TCQ182	59.90	TCQ214	180.00
M18 x 2.5	Metric Coarse	4	29	112	TCQ099	TCQ141	TCQ183	79.70	TCQ215	242.00
M20 x 2.5	Metric Coarse	4	29	112	TCQ100	TCQ142	TCQ184	110.00	TCQ216	329.00
M22 x 2.5	Metric Coarse	4	29	118	TCQ101	TCQ143	TCQ185	121.00	TCQ217	362.00
M24 x 3	Metric Coarse	4	35	130	TCQ102	TCQ144	TCQ186	147.00	TCQ218	439.00
M27 x 3	Metric Coarse	4	35	135	TCQ103	TCQ145	TCQ187	260.00	-	-
M30 x 3.5	Metric Coarse	4	41	138	TCQ104	TCQ146	TCQ188	341.00	-	-
M33 x 3.5	Metric Coarse	4	41	151	TCQ105	TCQ147	TCQ189	445.00	-	-
M36 x 4	Metric Coarse	4	47	162	TCQ106	TCQ148	TCQ190	497.00	-	-
M39 x 4	Metric Coarse	4	47	170	TCQ107	TCQ149	TCQ191	547.00	-	-
M42 x 4.5	Metric Coarse	6	53	170	TCQ108	TCQ150	TCQ192	696.00	-	-
M45 x 4.5	Metric Coarse	6	54	187	TCQ109	TCQ151	TCQ193	952.00	-	-
M48 x 5	Metric Coarse	6	60	187	TCQ110	TCQ152	TCQ194	1015.00	-	-
M52 x 5	Metric Coarse	6	60	200	-	-	TCQ195	1158.00	-	-
M56 x 5.5	Metric Coarse	6	60	200	-	-	TCQ196	1269.00	-	-

WIZARD SPIRAL POINT MACHINE TAPS - NC & NF

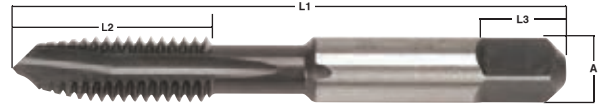

CLARKSON  **OSBORN**

Size	Thread Form	L2"	L1"	L3"	A"	Flutes	Blue Wizard Model No.	Mfg. No.	Price /Each	White Wizard Model No.	Mfg. No.	Price /Each	Gold Wizard Model No.	Mfg. No.	Price /Each
0-80	NF	3/8	1 5/8	3/16	0.110	2	BF370	CT72100	39.50	-	-	-	TBM048	CT79100	51.90
1-64	NC	7/16	1 11/16	3/16	0.110	2	BF367	CT72001	38.90	-	-	-	TBM049	CT79001	51.90
1-72	NF	7/16	1 11/16	3/16	0.110	2	BF371	CT72101	39.50	-	-	-	TBM050	CT79101	51.90
2-56	NC	1/2	1 3/4	3/16	0.110	2	BF368	CT72002	25.50	-	-	-	BF544	CT79002	34.90
2-64	NF	1/2	1 3/4	3/16	0.110	2	BF372	CT72102	25.50	-	-	-	TBM051	CT79102	34.90
3-48	NC	9/16	1 13/16	3/16	0.110	2	BF369	CT72003	22.90	-	-	-	TBM052	CT79003	34.90
3-56	NF	9/16	1 13/16	3/16	0.110	2	BF373	CT72103	22.90	-	-	-	TBM053	CT79103	34.90
4-40	NC	5/8	1 7/8	3/16	0.110	2	QD614	CT72004	20.90	BF390	CT73004	24.90	TBM054	CT79004	32.90
4-48	NF	5/8	1 7/8	3/16	0.110	2	BF374	CT72104	20.90	BF400	CT73104	24.90	BF550	CT79104	32.90
5-40	NC	11/16	1 15/16	3/16	0.110	2	QD615	CT72005	20.90	BF391	CT73005	24.90	BF545	CT79005	32.90
5-44	NF	11/16	1 15/16	3/16	0.110	2	BF375	CT72105	20.90	BF401	CT73105	24.90	BF551	CT79105	32.90
6-32	NC	11/16	2	3/16	0.110	2	QD616	CT72006	14.50	BF392	CT73006	19.90	BF546	CT79006	25.50
6-40	NF	11/16	2	3/16	0.110	2	BF376	CT72106	13.90	BF402	CT73106	19.90	TBM055	CT79106	25.50
8-32	NC	3/4	2 1/8	1/4	0.131	2	QD617	CT72008	14.50	BF393	CT73008	20.90	BF547	CT79008	25.50
8-36	NF	3/4	2 1/8	1/4	0.131	2	BF377	CT72108	13.90	BF403	CT73108	20.90	TBM056	CT79108	25.50
10-24	NC	11/16	2 3/8	1/4	0.152	2	QD618	CT72010	14.50	BF394	CT73010	20.90	BF548	CT79010	25.50
10-32	NF	11/16	2 3/8	1/4	0.152	2	-	-	-	BF404	CT73110	20.90	BF552	CT79110	25.50
12-24	NC	11/16	2 3/8	9/32	0.165	2	QD619	CT72012	18.50	BF395	CT73012	22.90	BF549	CT79012	30.50
12-28	NF	11/16	2 3/8	9/32	0.165	2	QD621	CT72120	18.50	BF405	CT73120	22.90	TBM057	CT79120	30.50
1/4-20	NC	13/16	2 1/2	5/16	0.191	2	QD622	CT72404	14.90	BF406	CT73404	19.50	BF553	CT79404	26.50
1/4-28	NF	13/16	2 1/2	5/16	0.191	2	QD631	CT72504	14.90	BF416	CT73504	19.50	BF561	CT79504	26.50
5/16-18	NC	7/8	2 23/32	3/8	0.238	3	QD623	CT72405	15.90	BF407	CT73405	27.50	BF554	CT79405	34.90
5/16-24	NF	7/8	2 23/32	3/8	0.238	3	QD632	CT72505	15.90	BF417	CT73505	27.50	BF562	CT79505	34.90
3/8-16	NC	1	2 15/16	7/16	0.286	3	QD624	CT72406	21.50	BF408	CT73406	27.50	BF555	CT79406	40.50
3/8-24	NF	1	2 15/16	7/16	0.286	3	QD633	CT72506	21.50	BF418	CT73506	27.50	BF563	CT79506	40.50
7/16-14	NC	1 1/16	3 5/32	13/32	0.242	3	QD625	CT72407	30.50	BF409	CT73407	37.90	BF556	CT79407	52.50
7/16-20	NF	1 1/16	3 5/32	13/32	0.242	3	QD634	CT72507	30.50	BF419	CT73507	37.90	BF564	CT79507	52.50
1/2-13	NC	1 3/16	3 3/8	7/16	0.275	3	QD626	CT72408	31.50	BF410	CT73408	39.90	BF557	CT79408	55.50
1/2-20	NF	1 3/16	3 3/8	7/16	0.275	3	QD635	CT72508	31.50	BF420	CT73508	39.90	BF565	CT79508	55.50
9/16-12	NC	1 3/16	3 19/32	1/2	0.322	3	-	-	-	BF411	CT73409	75.50	BF558	CT79409	79.90
9/16-18	NF	1 3/16	3 19/32	1/2	0.322	3	QR181	CT72509	54.90	BF421	CT73509	75.50	BF566	CT79509	79.90
5/8-11	NC	1 3/8	3 13/16	9/16	0.360	3	QD627	CT72410	61.90	BF412	CT73410	81.50	BF559	CT79410	96.50
5/8-18	NF	1 3/8	3 13/16	9/16	0.360	3	QD636	CT72510	66.90	BF422	CT73510	48.50	TBM058	CT79510	96.50
3/4-10	NC	1 7/16	4 1/4	11/16	0.442	3	QD628	CT72412	87.50	BF413	CT73412	105.00	TBM059	CT79412	139.00
3/4-16	NF	1 7/16	4 1/4	11/16	0.442	3	QD637	CT72512	79.50	BF423	CT73512	89.90	BF567	CT79512	139.00
7/8-9	NC	1 5/8	4 11/16	3/4	0.523	3	QD629	CT72414	109.00	BF414	CT73414	135.00	TBM060	CT79414	169.00
7/8-14	NF	1 5/8	4 11/16	3/4	0.523	3	QR186	CT72514	109.00	BF424	CT73514	135.00	TBM061	CT79514	169.00
1-8	NC	1 3/4	5 1/8	13/16	0.600	4	QD630	CT72416	139.00	BF415	CT73416	169.00	BF560	CT79416	199.00
1-12	NF	1 3/4	5 1/8	13/16	0.600	4	QR161	CT72516	139.00	BF425	CT73516	169.00	TBM062	CT79516	199.00

WIZARD SPIRAL POINT MACHINE TAPS - METRIC

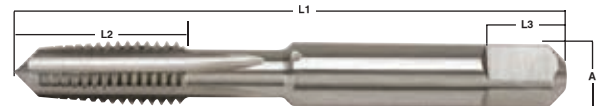

CLARKSON  **OSBORN**

Size	L2 mm	L1 mm	L3 mm	A mm	Flutes	Blue Wizard Model No.	Mfg. No.	Price /Each	Gold Wizard Model No.	Mfg. No.	Price /Each
M2.0 x 0.40	8.0	41.0	4.0	2.00	3	BF350	CT71020	29.90	TBM035	CT78020	42.50
M2.5 x 0.45	9.5	44.5	5.0	2.24	3	BF351	CT71025	24.90	TBM036	CT78025	37.50
M3.0 x 0.50	15.0	48.0	5.0	2.50	3	QR162	CT71030	19.50	BF535	CT78030	31.50
M3.5 x 0.60	17.0	50.0	5.0	2.80	3	QR163	CT71035	19.50	TBM037	CT78035	31.50
M4.0 x 0.70	17.0	53.0	6.0	3.15	3	QR164	CT71040	15.90	BF536	CT78040	28.50
M4.5 x 0.75	17.0	53.0	6.0	3.55	3	BF352	CT71045	21.50	TBM038	CT78045	33.90
M5.0 x 0.80	16.0	58.0	7.0	4.00	3	QR165	CT71050	17.90	BF537	CT78050	30.50
M6.0 x 1.00	19.0	66.0	8.0	5.00	3	QR166	CT71060	18.50	BF538	CT78060	30.90
M7.0 x 1.00	19.0	66.0	8.0	5.60	3	BF353	CT71070	23.90	TBM039	CT78070	43.90
M8.0 x 1.25	22.0	72.0	9.0	6.30	3	QR167	CT71080	19.90	BF539	CT78080	40.50
M10.0 x 1.50	24.0	80.0	11.0	8.00	3	QR168	CT71100	27.50	BF540	CT78100	52.50
M12.0 x 1.75	29.0	89.0	10.0	7.10	3	QR101	CT71120	43.90	BF541	CT78120	69.50
M14.0 x 2.00	30.0	95.0	12.0	9.00	3	QR172	CT71140	56.50	BF542	CT78140	83.90
M16.0 x 2.00	32.0	102.0	13.0	10.00	3	QR112	CT71160	69.90	BF543	CT78160	119.00
M18.0 x 2.50	37.0	112.0	14.0	11.20	3	BF354	CT71180	94.90	TBM040	CT78180	145.00
M20.0 x 2.50	37.0	112.0	14.0	11.20	3	QR160	CT71200	125.00	TBM041	CT78200	189.00
M22.0 x 2.50	38.0	118.0	16.0	12.50	3	BF355	CT71220	145.00	TBM042	CT78220	215.00
M24.0 x 3.00	45.0	130.0	18.0	14.00	3	QR183	CT71240	165.00	TBM043	CT78240	235.00

CUTTING TOOLS



SPIRAL POINT TAPS

- Material: High Speed Cobalt
- Manufacturing Standards: ANSI
- Cutting Direction: Right Hand
- Chamfer Type: Plug
- Tolerance: 3B

EO25 & EO35 SERIES - BRIGHT FLUTE & BRONZE BODY FINISH

- Premium substrate for through hole tapping in tough or abrasive materials
- Bronze oxide body and shank reduces rust and corrosion
- Bright finish flutes improve chip flow in soft or non-ferrous materials

Note: Reinforced shanks: Sizes 6-32 to 3/8"-24
Reduced shanks: Sizes 7/16"-14 to 1"-14



Model No.	Thread Size	Thread Form	No. of Flutes	L2"	L1"	Limits	Price /Each
TCP825	6-32	Unified Coarse	2	0.2610	2	H2	15.20
TCP868	6-40	Unified Fine	2	0.261	2	H2	17.10
TCP826	8-32	Unified Coarse	2	0.2484	2-1/8	H2	15.20
TCP869	8-36	Unified Fine	2	0.2484	2-1/8	H2	17.10
TCP827	10-24	Unified Coarse	2	0.4303	2-3/8	H3	15.20
TCP870	10-32	Unified Fine	3	0.4303	2-3/8	H2	15.20
TCP828	12-24	Unified Coarse	3	0.4173	2-3/8	H3	17.10
TCP829	1/4"-20	Unified Coarse	2	0.5075	2-1/2	H3	15.20
TCP830	1/4"-20	Unified Coarse	3	0.5075	2-1/2	H3	15.20
TCP871	1/4"-28	Unified Fine	2	0.5075	2-1/2	H3	15.20
TCP872	1/4"-28	Unified Fine	3	0.5075	2-1/2	H3	15.20
TCP831	5/16"-18	Unified Coarse	2	0.5939	2-23/32	H3	16.50
TCP832	5/16"-18	Unified Coarse	3	0.5939	2-23/32	H3	16.50
TCP873	5/16"-24	Unified Fine	2	0.5939	2-23/32	H3	16.50
TCP874	5/16"-24	Unified Fine	3	0.5939	2-23/32	H3	16.50
TCP833	3/8"-16	Unified Coarse	2	0.602	2-15/16	H3	19.60
TCP834	3/8"-16	Unified Coarse	3	0.602	2-15/16	H3	19.60
TCP875	3/8"-24	Unified Fine	3	0.602	2-15/16	H3	19.60

Model No.	Thread Size	Thread Form	No. of Flutes	L2"	L1"	Limits	Price /Each
TCP876	3/8"-24	Unified Fine	2	0.602	2-15/16	H3	19.60
TCP835	7/16"-14	Unified Coarse	3	0.9055	3-5/32	H3	32.90
TCP877	7/16"-20	Unified Fine	3	0.9055	3-5/32	H3	32.90
TCP836	1/2"-13	Unified Coarse	3	0.9055	3-3/8	H3	33.70
TCP837	1/2"-13	Unified Coarse	3	0.9055	3-3/8	H3	33.70
TCP878	1/2"-20	Unified Fine	3	0.9055	3-3/8	H3	38.70
TCP879	1/2"-20	Unified Fine	3	0.9055	3-3/8	H3	38.70
TCP838	9/16"-12	Unified Coarse	3	0.9843	3-19/32	H3	65.90
TCP880	9/16"-18	Unified Fine	3	0.9843	3-19/32	H3	65.90
TCP839	5/8"-11	Unified Coarse	3	0.9843	3-13/16	H3	74.20
TCP881	5/8"-18	Unified Fine	3	0.9843	3-13/16	H3	78.60
TCP840	3/4"-10	Unified Coarse	3	1.1614	4-1/4	H4	107.00
TCP882	3/4"-16	Unified Fine	3	1.1614	4-1/4	H3	112.00
TCP841	7/8"-9	Unified Coarse	2	1.1614	4-11/16	H4	146.00
TCP883	7/8"-14	Unified Fine	3	1.1614	4-11/16	H4	146.00
TCP842	1"-8	Unified Coarse	2	1.3976	5-1/8	H4	181.00
TCP884	1"-14	Unified Fine	2	1.3976	5-1/8	H4	186.00

EO26 & EO36 SERIES - STEAM OXIDE FINISH

- Premium substrate with steam oxide surface treatment reduces wear and prevents chip welding in abrasive or harder ferrous materials

Note: Reinforced Shanks: Sizes 2-56 to 3/8"-24
Reduced Shanks: Sizes 7/16"-14 to 1"-14



Model No.	Thread Size	Thread Form	No. of Flutes	L2"	L1"	Limits	Price /Each
TCP843	2-56	Unified Coarse	2	0.314	1-3/4	H2	29.70
TCP844	4-40	Unified Coarse	2	0.6091	1-7/8	H2	18.50
TCP845	5-40	Unified Coarse	2	0.7404	1-15/16	H2	18.50
TCP846	6-32	Unified Coarse	2	0.261	2	H2	15.20
TCP847	8-32	Unified Coarse	2	0.2484	2-1/8	H2	15.20
TCP848	10-24	Unified Coarse	2	0.4303	2-3/8	H3	15.20
TCP885	10-32	Unified Fine	2	0.4303	2-3/8	H2	15.20
TCP849	12-24	Unified Coarse	3	0.4173	2-3/8	H3	17.10
TCP886	12-28	Unified Fine	2	0.4173	2-3/8	H3	16.40
TCP850	1/4"-20	Unified Coarse	3	0.5075	2-1/2	H3	15.20
TCP851*	1/4"-20	Unified Coarse	3	0.5075	2-1/2	H11	15.10
TCP852	1/4"-20	Unified Coarse	3	0.5075	2-1/2	H3	15.20
TCP887	1/4"-28	Unified Fine	2	0.5075	2-1/2	H3	15.20
TCP888	1/4"-28	Unified Fine	3	0.5075	2-1/2	H3	15.20
TCP853	5/16"-18	Unified Coarse	3	0.5939	2-23/32	H3	16.50
TCP854*	5/16"-18	Unified Coarse	2	0.5939	2-23/32	H11	16.50
TCP855	5/16"-18	Unified Coarse	3	0.5939	2-23/32	H3	16.50
TCP889	5/16"-24	Unified Fine	2	0.5939	2-23/32	H3	15.90
TCP890	5/16"-24	Unified Fine	3	0.5939	2-23/32	H3	15.90
TCP856	3/8"-16	Unified Coarse	3	0.602	2-15/16	H3	19.60
TCP857*	3/8"-16	Unified Coarse	3	0.602	2-15/16	H11	19.60

* Tolerance: Oversize +0.005", not 3B

Model No.	Thread Size	Thread Form	No. of Flutes	L2"	L1"	Limits	Price /Each
TCP858	3/8"-16	Unified Coarse	3	0.602	2-15/16	H3	19.60
TCP891	3/8"-24	Unified Fine	2	0.602	2-15/16	H3	19.60
TCP892	7/16"-20	Unified Fine	3	0.9055	3-5/32	H3	32.90
TCP860	1/2"-13	Unified Coarse	3	0.9055	3-3/8	H3	33.70
TCP861*	1/2"-13	Unified Coarse	3	0.9055	3-3/8	H11	33.70
TCP862	1/2"-13	Unified Coarse	3	0.9055	3-3/8	H3	33.70
TCP893	1/2"-20	Unified Fine	3	0.9055	3-3/8	H3	38.70
TCP894	1/2"-20	Unified Fine	2	0.9055	3-3/8	H3	38.70
TCP863	9/16"-12	Unified Coarse	3	0.9843	3-19/32	H3	65.90
TCP895	9/16"-18	Unified Fine	3	0.9843	3-19/32	H3	65.90
TCP864*	5/8"-11	Unified Coarse	3	0.9843	3-13/16	H11	74.20
TCP865	5/8"-11	Unified Coarse	3	0.9843	3-13/16	H3	74.20
TCP896	5/8"-18	Unified Fine	3	0.9843	3-13/16	H3	78.60
TCP866	3/4"-10	Unified Coarse	2	1.1614	4-1/4	H4	107.00
TCP897	3/4"-16	Unified Fine	3	1.1614	4-1/4	H3	112.00
TCP867	7/8"-9	Unified Coarse	2	1.1614	4-11/16	H4	146.00
TCP898	7/8"-14	Unified Fine	3	1.1614	4-11/16	H4	146.00
TCP899	1"-12	Unified Fine	3	1.3976	5-1/8	H4	181.00
TCP900	1"-14	Unified Fine	3	1.3976	5-1/8	H4	186.00



SPIRAL FLUTE TAPS 45°

- Material: High Speed Cobalt
- Manufacturing Standards: ANSI
- Chamfer Type: Semi-Bottoming
- Tolerance: 3B
- Cutting Direction: Right Hand

EO27 & EO37 SERIES - BRIGHT FLUTES & BRONZE OXIDE BODY FINISH

- Premium substrate for blind hole tapping in tough or abrasive materials
- Bronze oxide body and shank reduces rust and corrosion
- Bright finish flutes improve chip flow in soft and non-ferrous materials

Model No.	Thread Size	Thread Form	No. of Flutes	L2"	L1"	Limits	Price /Each
TCQ017	6-32	Unified Coarse	3	0.261	2	H2	28.60
TCQ018	8-32	Unified Coarse	3	0.2484	2-1/8	H2	28.60
TCQ019	10-24	Unified Coarse	3	0.265	2-3/8	H3	28.60
TCQ047	10-32	Unified Fine	3	0.265	2-3/8	H2	28.60
TCQ020	12-24	Unified Coarse	3	0.252	2-3/8	H3	30.90
TCQ021	1/4"-20	Unified Coarse	3	0.3937	2-1/2	H3	32.40
TCQ048	1/4"-28	Unified Fine	3	0.3937	2-1/2	H3	32.40
TCQ022	5/16"-18	Unified Coarse	3	0.4567	2-23/32	H3	40.10
TCQ049	5/16"-24	Unified Fine	3	0.4567	2-23/32	H3	40.10
TCQ023	3/8"-16	Unified Coarse	3	0.5315	2-15/16	H3	46.20
TCQ050	3/8"-24	Unified Fine	3	0.5315	2-15/16	H3	46.20
TCQ024	7/16"-14	Unified Coarse	3	0.6299	3-5/32	H3	69.00
TCQ051	7/16"-20	Unified Fine	3	0.6299	3-5/32	H3	69.00

EO28 & EO38 SERIES - STEAM OXIDE FINISH

- Premium substrate with steam oxide surface treatment reduces wear and prevents chip welding in abrasive or harder ferrous materials

Note: Reinforced shanks: Sizes 4-40 to 3/8"-24
Reduced shanks: Sizes 7/16"-14 to 1"-14

Model No.	Thread Size	Thread Form	No. of Flutes	L2"	L1"	Limits	Price /Each
TCQ031	4-40	Unified Coarse	3	0.6091	1-7/8	H2	30.50
TCQ032	5-40	Unified Coarse	3	0.7404	1-15/16	H2	30.50
TCQ033	6-32	Unified Coarse	3	0.261	2	H2	28.60
TCQ034	8-32	Unified Coarse	3	0.2484	2-1/8	H2	28.60
TCQ035	10-24	Unified Coarse	3	0.265	2-3/8	H3	28.60
TCQ058	10-32	Unified Fine	3	0.265	2-3/8	H2	28.60
TCQ036	12-24	Unified Coarse	3	0.252	2-3/8	H3	30.90
TCQ037	1/4"-20	Unified Coarse	3	0.3937	2-1/2	H3	32.40
TCQ059	1/4"-28	Unified Fine	3	0.3937	2-1/2	H3	32.40
TCQ038	5/16"-18	Unified Coarse	3	0.4567	2-23/32	H3	40.10
TCQ060	5/16"-24	Unified Fine	3	0.4567	2-23/32	H3	40.10
TCQ039	3/8"-16	Unified Coarse	3	0.5315	2-15/16	H3	46.20
TCQ061	3/8"-24	Unified Fine	3	0.5315	2-15/16	H3	46.20
TCQ040	7/16"-14	Unified Coarse	3	0.6299	3-5/32	H3	69.00

SPIRAL FLUTE TAP 45°

- Material: High Speed Cobalt
- Manufacturing Standards: ISO 529
- Helix Angle: 45°
- Cutting Direction: Right Hand
- Chamfer Type: Semi-Bottoming
- Tolerance: 6H

Note: ISO shank and square dimensions require metric holders

EO02 SERIES - BRIGHT FLUTE & BRONZE OXIDE BODY FINISH

- Premium substrate for blind hole tapping in tough or abrasive materials
- Bronze oxide body and shank reduces rust and corrosion
- Bright finish flutes improve chip flow in soft and non-ferrous materials

Note: Reinforced shanks: Sizes M2 x 0.4 to M10 x 1.5
Reduced shanks: Sizes M12 x 1.75 to M24 x 3

Model No.	Thread Size	Thread Form	No. of Flutes	L2 mm	L1 mm	Limits	Price /Each
TCP968	M2 x 0.4	Metric Coarse	2	8	41	D3	55.90
TCP969	M2.5 x 0.45	Metric Coarse	2	9.5	44.5	D3	37.80
TCP970	M3 x 0.5	Metric Coarse	3	6	48	D3	25.00
TCP971	M4 x 0.7	Metric Coarse	3	7	53	D4	22.20
TCP972	M5 x 0.8	Metric Coarse	3	8	58	D4	24.70
TCP973	M6 x 1	Metric Coarse	3	10	66	D5	25.00
TCP974	M8 x 1.25	Metric Coarse	3	12	72	D5	27.80
TCP975	M10 x 1.5	Metric Coarse	3	15	80	D6	34.20

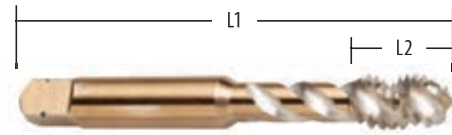

Model No.	Thread Size	Thread Form	No. of Flutes	L2"	L1"	Limits	Price /Each
TCQ025	1/2"-13	Unified Coarse	3	0.689	3-3/8	H3	81.80
TCQ052	1/2"-20	Unified Fine	3	0.689	3-3/8	H3	81.80
TCQ026	9/16"-12	Unified Coarse	3	0.7087	3-19/32	H3	137.00
TCQ053	9/16"-18	Unified Fine	3	0.7087	3-19/32	H3	137.00
TCQ027	5/8"-11	Unified Coarse	3	0.7087	3-13/16	H3	137.00
TCQ054	5/8"-18	Unified Fine	3	0.7087	3-13/16	H3	137.00
TCQ028	3/4"-10	Unified Coarse	3	0.8858	4-1/4	H4	187.00
TCQ055	3/4"-16	Unified Fine	3	0.8858	4-1/4	H3	187.00
TCQ029	7/8"-9	Unified Coarse	3	0.9843	4-11/16	H4	236.00
TCQ056	7/8"-14	Unified Fine	3	0.9843	4-11/16	H4	236.00
TCQ030	1"-8	Unified Coarse	3	1.1811	5-1/8	H4	311.00
TCQ057	1"-14	Unified Fine	3	1.1811	5-1/8	H4	311.00



Model No.	Thread Size	Thread Form	No. of Flutes	L2"	L1"	Limits	Price /Each
TCQ062	7/16"-20	Unified Fine	3	0.6299	3-5/32	H3	69.00
TCQ041	1/2"-13	Unified Coarse	3	0.689	3-3/8	H3	81.80
TCQ063	1/2"-20	Unified Fine	3	0.689	3-3/8	H3	81.80
TCQ042	9/16"-12	Unified Coarse	3	0.7087	3-19/32	H3	137.00
TCQ064	9/16"-18	Unified Fine	3	0.7087	3-19/32	H3	137.00
TCQ043	5/8"-11	Unified Coarse	3	0.7087	3-13/16	H3	137.00
TCQ065	5/8"-18	Unified Fine	3	0.7087	3-13/16	H3	137.00
TCQ044	3/4"-10	Unified Coarse	3	0.8858	4-1/4	H4	187.00
TCQ066	3/4"-16	Unified Fine	3	0.8858	4-1/4	H3	187.00
TCQ045	7/8"-9	Unified Coarse	3	0.9843	4-11/16	H4	236.00
TCQ067	7/8"-14	Unified Fine	3	0.9843	4-11/16	H4	236.00
TCQ046	1"-8	Unified Coarse	3	1.1811	5-1/8	H4	311.00
TCQ068	1"-14	Unified Fine	3	1.1811	5-1/8	H4	311.00

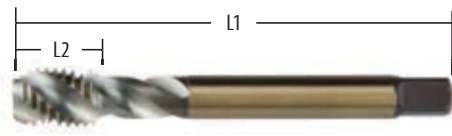

Model No.	Thread Size	Thread Form	No. of Flutes	L2 mm	L1 mm	Limits	Price /Each
TCP976	M12 x 1.75	Metric Coarse	3	16	89	D6	49.30
TCP977	M14 x 2	Metric Coarse	3	18	95	D7	75.80
TCP978	M16 x 2	Metric Coarse	4	18	102	D7	75.20
TCP979	M18 x 2.5	Metric Coarse	4	29	112	D7	122.00
TCP980	M20 x 2.5	Metric Coarse	4	29	112	D7	134.00
TCP981	M22 x 2.5	Metric Coarse	4	29	118	D8	157.00
TCP982	M24 x 3	Metric Coarse	4	35	130	D8	180.00

CUTTING TOOLS

SPIRAL FLUTE TAP 45° (CONT.)

E003 & EO13 SERIES - STEAM OXIDE FINISH

- Premium substrate with steam oxide surface treatment reduces wear and prevents chip welding in abrasive or harder ferrous materials

Note: Reinforced shanks: sizes M2 x 0.4 to M10 x 1.25
Reduced shanks: sizes M12 x 1 to M24 x 3

Model No.	Thread Size	Thread Form	No. of Flutes	L2 mm	L1 mm	Limits	Price /Each
TCP983	M2x0.4	Metric Coarse	2	8	41	D3	55.90
TCP984	M2.5x0.45	Metric Coarse	2	9.5	44.5	D3	37.80
TCP985	M3x0.5	Metric Coarse	3	6	48	D3	25.00
TCP998	M4x0.5	Metric Fine	3	7	53	D4	52.00
TCP986	M4x0.7	Metric Coarse	3	7	53	D4	22.20
TCP999	M5x0.5	Metric Fine	3	8	58	D4	45.80
TCP987	M5x0.8	Metric Coarse	3	8	58	D4	24.70
TCQ000	M6x0.5	Metric Fine	3	10	66	D5	57.30
TCQ001	M6x0.75	Metric Fine	3	10	66	D5	57.30
TCP988	M6x1	Metric Coarse	3	10	66	D5	25.00
TCQ002	M8x0.75	Metric Fine	3	12	72	D5	66.60
TCQ003	M8x1	Metric Fine	3	12	72	D5	66.60
TCP989	M8x1.25	Metric Coarse	3	12	72	D5	27.80
TCQ004	M10x1	Metric Fine	3	15	80	D6	77.80
TCQ005	M10x1.25	Metric Fine	3	15	80	D6	77.80
TCP990	M10x1.5	Metric Coarse	3	15	80	D6	34.20



Model No.	Thread Size	Thread Form	No. of Flutes	L2 mm	L1 mm	Limits	Price /Each
TCQ006	M12x1	Metric Fine	3	16	89	D6	107.00
TCQ007	M12x1.25	Metric Fine	3	16	89	D6	107.00
TCQ008	M12x1.5	Metric Fine	3	16	89	D6	107.00
TCP991	M12x1.75	Metric Coarse	3	16	89	D6	49.30
TCQ009	M14x1.5	Metric Fine	3	18	95	D7	140.00
TCP992	M14x2	Metric Coarse	3	18	95	D7	75.80
TCQ010	M16x1	Metric Fine	4	18	102	D7	161.00
TCQ011	M16x1.5	Metric Fine	4	18	102	D7	161.00
TCP993	M16x2	Metric Coarse	4	18	102	D7	75.20
TCQ012	M18x1.5	Metric Fine	4	29	112	D7	232.00
TCP994	M18x2.5	Metric Coarse	4	29	112	D7	122.00
TCQ013	M20x1.5	Metric Fine	4	29	112	D7	254.00
TCP995	M20x2.5	Metric Coarse	4	29	112	D7	134.00
TCQ014	M22x1.5	Metric Fine	4	29	112	D8	298.00
TCP996	M22x2.5	Metric Coarse	4	29	118	D8	157.00
TCP997	M24x3	Metric Coarse	4	35	130	D8	180.00

MEDIUM HOOK PIPE TAPS

E710 SERIES

- Generally used for pipe fittings and couplings in most ferrous and non-ferrous materials
- Medium hook for multi-material tapping
- Straight flute
- Material: High Speed Steel
- Thread Form: National Taper Pipe
- Manufacturing Standards: ANSI B94.9
- Finish: Bright
- Cutting Direction: Right Hand

Note: NPT threads require the use of a sealant such as teflon tape or pipe compound to ensure a tight joint

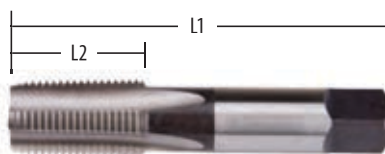

Model No.	Pipe Size	No. of Flutes	L2 mm	L1 mm	Price /Each
TCP958	1/16"-27	4	17	65	38.70
TCP959	1/8"-27	4	19	70	38.70
TCP960	1/4"-18	4	27	75	42.00
TCP961	3/8"-18	4	27	80	55.30
TCP962	1/2"-14	4	35	100	87.00
TCP963	3/4"-14	5	35	105	124.00
TCP964	1"-11.5	5	43	115	187.00
TCP965	1-1/4"-11.5	5	43	125	266.00
TCP966	1-1/2"-11.5	7	43	135	364.00
TCP967	2"-11.5	7	43	145	489.00



STRAIGHT HANDLE TAP WRENCHES

3850 SERIES

- Ideal for hand tapping
- Hardened steel jaws are opened and closed by simply twisting one hand which is knurled for side gripping



Model No.	Imperial Hand Tap Capacity"	Metric Hand Tap Capacity	Hand Reamer Capacity"	Size	Price /Each
TCP921	1/16 - 5/16	M1 - M8	1/8 - 5/16	#8	329.00
TCP923	1/4 - 3/4	M3 - M18	1/4 - 9/16	#10	430.00
TCP924	3/8 - 1	M10 - M25	3/8 - 3/4	#11	720.00
TCP926	7/8 - 1-7/8	M22 - M42	5/8 - 1-1/2	#14	963.00

M2 SAE TAP

- Made of hardened and tempered M2 High Speed Steel for fast threading and long service life
- Ideal for industrial applications (production work) as well as automotive, agri-motive and machine shop applications
- Material: High Speed Steel
- Rockwell Hardness: HRC 62-64



Model No.	Mfg. No.	Thread Size	Chamfer Type	Drill Size	Price /Each
UAV986	530219	10-24NC	Taper	#25	13.40
UAV987	530226	1/4"-20	Plug	13/64"	13.00
UAV988	530232	3/8"-16	Plug	5/16"	19.60

ALLOY PIPE TAP

- Standard hex design for threading and rethreading applications
- Type: Taper
- Rockwell Hardness: HRC 55-59



Model No.	Mfg. No.	Pipe Size	Drill Size	Price /Each
UAV989	530404	1/2"-14	45/64"	55.30
UAV990	530410	1-1/2"-11.5	1-47/64"	289.00

PREMIUM METRIC ALLOY TAP & DIE SET

- No. of Pieces: 40
- Includes: 3mm-0.50 Hex die & plug tap, 3mm-0.60, 4mm-0.70 Hex die & plug tap, 4mm-0.75 Hex die & plug tap, 5mm-0.80 Hex die & plug tap, 5mm-0.90 Hex die & plug tap, 6mm-0.75 Hex die & plug tap, 6mm-1.00 Hex die & plug tap, 7mm-0.75 Hex die & plug tap, 7mm-1.00 Hex die & plug tap, 8mm-1.00 Hex die & plug tap, 8mm-1.25 Hex die & plug tap, 10mm-1.25 Hex die & plug tap, 10mm-1.50 Hex die & plug tap, 12mm-1.50 Hex die & plug tap, 12mm-1.75 Hex die & plug tap, 1/8-27 NPT Hex die & plug tap, Adjustable long-handled tap wrench, T-handle 1/16-3/16 shank taps, Hex die stock, Slot screwdriver, Metric Pitch Gauge, Blow mould case

Model No. UAV985
Mfg. No. 530117
Price/Each \$195.00



PREMIUM SAE ALLOY TAP & DIE SET

- No. of Pieces: 40
- Includes: #4-40 Hex die and plug, #6-32 Hex die and plug, #8-32 Hex die and plug, #10-24 Hex die and plug, #10-32 Hex die and plug, #12-24 Hex die and plug, 1/4-20 Hex die and plug, 1/4-28 Hex die and plug, 5/16-18 Hex die and plug, 5/16-24 Hex die and plug, 3/8-16 Hex die and plug, 3/8-24 Hex die and plug, 7/16-14 Hex die and plug, 7/16-20 Hex die and plug, 1/2-20 Hex die and plug, 1/8-27 NPT Hex die and plug, Adjustable long-handled tap wrench, T-handle 1/16-3/16 shank taps, 1" Hex die stock, Slot screwdriver, SAE Pitch Gauge, Blow mould case

Model No. UAV984
Mfg. No. 530116
Price/Each \$195.00



JET-KUT® RATCHET TAP WRENCH

- Features a fine tooth ratcheting mechanism which adjusts on the fly for right and left-handed use
- Ratchet can be locked to transform the tool into a standard tap wrench
- Positive, left, or right ratchet with centre lock position increases performance and efficiency
- Ratcheting Mechanism offers increased performance and efficiency
- Type: Ratcheting T-Handle



Model No.	Mfg. No.	Imperial Hand Tap Capacity	Price /Each
AUW143	530991	0 - 1/4"	60.90
AUW144	530994	12 - 1/2"	79.20

BOLT BITER™ SCREW EXTRACTOR SET

- Tapered side and tip cutting edges for powerful and consistent extraction
- High strength steel provides up to 50 times longer life
- Bi-directional design loosens or tightens damaged fasteners
- Hex base design is compatible with hand and power tools
- High-visibility laser markings for easy size identification
- Compact storage solution for space-saving organization
- Black oxide coating provides superior corrosion resistance
- Compatible with fastener sizes ≤ 1/4" – 5/8" and M5-M16
- Packaging is recyclable
- No. of Pieces: 4

Model No. UAV703
Mfg. No. 84787
Price/Each \$30.10



SCREW EXTRACTORS

- Left hand rotation screw extractors
- Material: Chromium Steel



1800 SERIES

Model No.	Extractor Size	For Screw/Bolt Sizes"	For Pipe Sizes"	Overall Length"	Small End Diameter"	Shank Size"	Price /Each
TCP901	#1	3/16 - 1/4	-	2	0.054	5/32	8.71
TCP902	#2	1/4 - 5/16	-	2-3/8	0.086	3/16	8.86
TCP903	#3	5/16 - 7/16	-	2-3/4	1/8	1/4	10.90
TCP904	#4	7/16 - 9/16	-	3	11/64	5/16	11.50
TCP905	#5	9/16 - 3/4	1/8 - 1/4	3-3/8	1/4	7/16	14.70
TCP907	#7	1 - 1-3/8	1/2	4-1/8	31/64	3/4	52.00
TCP908	#8	1-3/8 - 1-3/4	3/4	4-3/8	47/64	1	70.30
TCP909	#9	1-3/4 - 2-1/8	1	4-5/8	31/32	1-1/4	122.00

1815 & 1816 SERIES

Model No.	Extractor Size	For Screw/Bolt Sizes"	For Pipe Sizes"	Price /Each
TCP914	#1 to #6	3/16 - 1	1/8 - 3/8	97.60

CUTTING TOOLS

QUIK-LOK™ FLAT BORING SETS

- 1/4" Quick-change hex shank provides quick and easy accessory changes
- Double wing spurs for easy hole formation and reduced vibration, preventing "break out"
- Patented cutting edge for easier and faster wood boring and fast chip removal which dissipates heat from the bit
- Includes: 6" universal Quik-Lok™ bit extension, 3/8", 1/2", 5/8", 3/4", 7/8", and 1-1/8" spade bits

Model No. TBO612
Price/Each \$30.50



Milwaukee

4-PIECE AUGER SETS

- Double wing spurs for clean hole cutting
- Non-stick coated flutes for faster chip ejection
- Impact rated shank
- Canvas roll-up pouch for easy storage and job site organization
- Includes: 1/2" auger bit, 3/4" auger bit, 7/8" auger bit, 1" auger bit

Model No. TBO615
Price/Each \$71.90

Milwaukee



6" SPEEDBOR FLAT BITS

- Blue-Groove point and cutting edge for faster chip removal, 4x faster than standard spade bits
- Double cutting spurs scribe the outside of the hole reducing breakout
- 10% larger shank for added durability
- Grooved hex shank prevents slipping in drill chuck or bit extension
- Fits all standard quick change chucks

IRWIN.



Diameter"	Shank Length"	Shank Size"	Model No.	Price /Each
1/4	6	1/4	TU937	4.69
5/16	6	1/4	TU938	4.69
3/8	6	1/4	TU939	4.69
7/16	6	1/4	TU940	4.69
1/2	6	1/4	TU941	4.69
9/16	6	1/4	TU942	4.99
5/8	6	1/4	TU943	5.19
11/16	6	1/4	TU944	5.19
3/4	6	1/4	TQ628	5.19
13/16	6	1/4	TQ629	5.49
7/8	6	1/4	TQ630	5.49
15/16	6	1/4	TQ631	5.79
1	6	1/4	TQ632	5.79
1-1/8	6	1/4	TQ633	8.29
1-1/4	6	1/4	TQ634	8.29
1-3/8	6	1/4	TQ635	8.29
1-1/2	6	1/4	TQ636	8.29

POWER DRILL LONG SHIP AUGER BITS

- Hollow centre flutes clear chips quickly out of holes
- Single cutter and side lip effortlessly bores holes in wood, cuts through nails without damaging the bit
- Full-length heat treatment guards against bending in heavy-duty applications and strengthens the twist where the greatest strain occurs
- Medium-fast screw point ideal for general wood boring applications
- Bit can be resharpened

IRWIN.



Diameter"	Shank Size"	Twist Length"	Overall Length"	Model No.	Price /Each
3/8	5/16 hex	12	17	TH663	37.90
7/16	5/16 hex	12	17	TH664	38.50
1/2	5/16 hex	12	17	TH665	38.90
9/16	7/16 hex	12	17	TH666	40.90
11/16	7/16 hex	12	17	TH668	45.50
3/4	7/16 hex	12	17	TH669	46.90
13/16	7/16 hex	12	17	TH670	48.90
7/8	7/16 hex	12	17	TH671	51.90
15/16	7/16 hex	12	17	TQ661	53.50
1	7/16 hex	12	17	TH673	55.90
1-1/8	7/16 hex	12	17	TH674	68.50
1-1/4	7/16 hex	12	17	TH675	78.90
1-3/8	7/16 hex	12	17	TH676	90.50
1/2	7/16 hex	12	17	TH677	95.90

SWITCHBLADE™ SELF-FEED BITS

- This innovative replaceable blade system provides maximum productivity by eliminating downtime and the cost to resharpen
- Designed for drilling holes in all types of wood for pipe, vents, gas lines, and bulk wire routing
- Aggressive feed screw design allows the bit to pull through the wood faster, resulting in faster drilling
- Replacement blades made with hardened steel increases bit life
- Size and model number engraved on each bit

Milwaukee

1-3/8" Switchblade™ Self-Feed Bits come with:

- 1-3/8" Switchblade™ self-feed bit
- 2 replaceable blades
- 2 feed screws
- 2 set screws
- One (1) hex wrench



REPLACEMENT PACKS

Dim."	Model No.	Price /Each	3 Blades		10 Blades	
			Model No.	Price /Each	Model No.	Price /Each
1-3/8	TB0301	43.60	TB0306	28.90	TB0311	61.80
1-1/2	TB0302	62.80	TB0307	29.50	TB0312	65.10
2	TB0303	74.10	TB0308	25.30	TB0313	65.80
2-1/8	TB0304	74.10	TB0309	26.60	TB0314	67.80
2-9/16	TB0305	97.90	TB0310	27.90	TB0315	84.90

NO JOB TOO TOUGH!

HOLE DOZER™ HOLE SAW



ICE HARDENED™ HOLE SAWS

Utilize a proprietary cryogenic hardening process that improves upon traditional heat treat processes. Unlike surface coatings that wear away, cryogenics harden to the core by minimizing soft metal (austenite) and creating more hard metal (martensite).

Feature and benefits:

- Ice Hardened™ for up to 50% longer life than the competition
- Optimized tooth form for up to 2x faster cutting
- Functional slots for faster plug removal
- Matrix II bi-metal teeth for greater durability



Model No.	Saw diameter Inches	mm	Price /Each	Model No.	Saw diameter Inches	mm	Price /Each	Model No.	Saw diameter Inches	mm	Price /Each	Model No.	Saw diameter Inches	mm	Price /Each
TB0108	5/8	16	11.90	TB0122	1-1/2	38	12.50	TB0136	2-9/16	65	22.50	TB0150	4-1/4	108	46.90
TB0109	11/16	17	12.90	TB0123	1-9/16	40	13.50	TB0137	2-5/8	67	22.50	TB0151	4-3/8	111	58.50
TB0110	3/4	19	11.90	TB0124	1-5/8	41	13.50	TB0138	2-3/4	70	22.50	TB0152	4-1/2	114	64.50
TB0111	13/16	21	12.90	TB0125	1-11/16	43	13.50	TB0139	2-7/8	73	22.90	TCT518	4-5/8	117	59.90
TB0112	7/8	22	11.90	TB0126	1-3/4	44	16.90	TB0140	3	76	23.90	TB0153	4-3/4	121	76.50
TB0113	15/16	24	12.90	TB0127	1-13/16	46	16.90	TB0141	3-1/8	79	23.90	TB0154	5	127	79.50
TB0114	1	25	11.90	TB0128	1-7/8	48	16.90	TB0142	3-1/4	83	23.90	TB0155	5-1/2	140	105.00
TB0115	1-1/16	27	11.90	TB0129	2	51	16.90	TB0143	3-3/8	86	23.90	TB0156	6	152	81.90
TB0116	1-1/8	29	11.90	TB0130	2-1/16	52	20.50	TB0144	3-1/2	89	23.90				
TB0117	1-3/16	30	11.90	TB0131	2-1/8	54	20.50	TB0145	3-5/8	92	27.90				
TB0118	1-1/4	32	11.90	TB0132	2-1/4	57	20.50	TB0146	3-3/4	95	31.90				
TB0119	1-5/16	33	12.90	TB0133	2-5/16	59	20.50	TB0147	3-7/8	98	27.60				
TB0120	1-3/8	35	12.50	TB0134	2-3/8	60	20.50	TB0148	4	102	32.90				
TB0121	1-7/16	37	13.50	TB0135	2-1/2	64	22.50	TB0149	4-1/8	105	37.50				

Note: See online for arbors

AURORA

TOOLS

Celebrating
15
YEARS

EXCEEDING EXPECTATIONS

CUTTING TOOLS

HOLE DOZER™ HOLE SAW KITS

Ice Hardened™ products utilize a proprietary cryogenic hardening process (harden to the core by minimizing soft metal and creating more hard metal) that improves upon traditional heat treat processes.

Features and benefits:

- Ice Hardened™ for up to 50% longer life
- Optimized tooth form for up to 2x faster cutting
- Functional slots for faster plug removal

HOLE DOZER™ GENERAL PURPOSE HOLE SAW KIT

Includes:

- Eleven (11) hole saws: 3/4", 7/8", 1", 1 1/8", 1 3/8", 1 1/2", 1 3/4", 2", 2 1/8", 2 1/4", 2 1/2"
- (1) 3/8" Hex shank arbor
- (2) 3-1/2" Pilot bits,
- (1) 1/8" Hex key,
- (1) 7/16" No-wobble arbor

Model No. TBO157
Price/Each \$219.00



HOLE DOZER™ ALL PURPOSE PROFESSIONAL HOLE SAW KIT

Includes:

- Twenty-two (22) hole saws: 3/4", 7/8", 1", 1 1/8", 1 1/4", 1 3/8", 1 1/2", 1 3/4", 2", 2 1/8", 2 1/4", 2 1/2", 2 5/8", 3", 3 1/4", 3 3/8", 3 5/8", 3 3/4", 4 1/8", 4 1/4", 4 1/2", 4 3/4"
- (1) 3/8" Hex shank arbor
- (1) 7/16" Hex shank arbor
- (1) 7/16" No-wobble arbor
- (3) 3-1/2" Pilot bits
- (1) 1/8" Hex key

Model No. TBO165
Price/Each \$509.00



10-PC ELECTRICIANS ICE HARDENED™ HOLE SAW KIT

Includes:

- Six (6) hole saws: 7/8", 1-1/8", 1 3/8", 1 3/4", 2", 2 1/2"
- (1) 3/8" Hex shank arbor
- (2) 3-1/2" Pilot bits
- (1) 1/8" Hex key
- (1) 7/16" No-wobble arbor

Model No. TBO160
Price/Each \$149.00



HOLE DOZER™ MASTER ELECTRICIAN'S HOLE SAW KIT

Includes:

- Thirteen (13) hole saws: 3/4", 7/8", 1 1/8", 1 3/8", 1 3/4", 2", 2 1/4", 2 1/2", 2 5/8", 3", 3 5/8", 4 1/8", 4 3/4"
- (1) 3/8" Small thread arbor
- (1) 7/16" Large thread arbor
- (1) 1/4" x 3-1/2" HSS Pilot bit

Model No. TBO159
Price/Each \$315.00



HOLE DOZER™ HOLE SAW KIT

Includes:

- Six (6) hole saws: 1-1/2", 2", 2-1/2", 3", 3-5/8", 4-1/4"
- (2) 3-1/2" pilot bits
- (2) Arbors (7/16" no wobble arbor, 3/8" hex shank arbor)
- (1) 1/8" hex key

Model No. TER126
Price/Each \$189.00



BIG HAWG® KITS

- Carbide teeth allow the hole saw to cut through the toughest materials, including nails, cement board, shingles, plaster and stucco
- Offers extreme life utilizing advanced carbide technology
- Ideal for nail-embedded wood and abrasive material applications

7-PC BIG HAWG™ HOLE SAW SET

- Hole Saw Size Range: 2-1/8" - 3-5/8"

Model No. TCR334
Price/Each \$195.00



10-PC BIG HAWG™ HOLE SAW SET

- Hole Saw Size Range: 2-1/8" - 4-1/4"

Model No. TCR313
Price/Each \$369.00



HIGH PERFORMANCE SUPER SAWZALL® BLADES

Matrix II high speed steel teeth with 8% cobalt. Tough bi-metal design for the fastest cutting, longest blade life available. 1/2" universal tang.



Dimensions			TPI	Recommended for Cutting	Pack of 5 Model No.	Price /Each
L" x W" x Thick"						
WOOD CUTTING BLADES						
6 x 3/4 x 0.050			6	Very fast cutting nail embedded wood and	TW181	21.50
9 x 3/4 x 0.050			6	general roughing in	TW182	27.90
12 x 3/4 x 0.050			6		TW183	31.90
WOOD, NAIL EMBEDDED WOOD & DEMOLITION						
6 x 1.0 x 0.062			5	Plunge cutting	TW185	23.90
9 x 1.0 x 0.062			5	Demolition work	TW186	40.90
12 x 1.0 x 0.062			5	Long demolition blade	TW187	36.50
PLASTER CUTTING BLADE						
5 x 3/4 x 0.050			6	Cuts forward and backward stroke	TW188	16.90
METAL CUTTING BLADES						
6 x 3/4 x 0.035			14	Metal 3/16" thru 1/4"	TW189	18.50
6 x 3/4 x 0.035			18	Metal 1/8" thru 3/16"	TW190	18.50
9 x 3/4 x 0.035			18	Metal 1/8" thru 3/16"	TW191	22.50
6 x 3/4 x 0.035			24	Metal thinner than 1/8"	TW192	18.50
4 x 3/4 x 0.035			14	Metal 3/16" thru 1/4"	TE533	13.90
9 x 3/4 x 0.035			14	Metal 3/16" thru 1/4"	TE534	22.50
12 x 3/4 x 0.035			18	Metal 1/8" thru 3/16"	TE535	27.50
ALL PURPOSE BLADES						
6 x 3/4 x 0.050			8 1/2	All Woods, Nail Embedded	TW193	18.50
8 x 3/4 x 0.050			8 1/2	Composition Material, Plastic	TW194	23.50
12 x 3/4 x 0.050			8 1/2	Non-Ferrous Metals, Cast Iron	TW195	34.90



Wood Cutting Blade



Wood, Nail Embedded Wood and Demolition



Plaster Cutting Blade



Metal Cutting Blade



All Purpose Blade



Tungsten Carbide Blade

Dimensions			Type Grit	Recommended for Cutting	Pack of 3 Model No.	Price /Each
L" x W" x Thick"						
TUNGSTEN CARBIDE BLADES						
6 x 3/4 x 0.030			Coarse	Fibreglass, ceramic tile, stone brick,	TW197	25.90
9 x 3/4 x 0.039			Coarse	Plaster and marble	TE536	32.90

DIAMOND GRIT THE TORCH™ SAWZALL® BLADES

Features and benefits:

- D6A steel body, durable 1" tall profile for straighter and cleaner cuts
- Featuring industrial diamond grit embedded in high strength nickel
- Blades last up to 30x longer and cut 2x faster than traditional carbide grit blades

Dimensions			Type Grit	Recommended for Cutting	Model No.	Price /Each
L" x W" x Thick"						
6 x 1 x 0.042			Diamond coarse	Cast iron, hard tile (grade 5), ceramic tile, plaster,	TB0299	19.90
9 x 1 x 0.042			Diamond coarse	masonry, brick, fibreglass and other abrasive materials	TB0300	22.90



SAWZALL® TORCH™ RECIPROCATING SAW BLADES

- Nitrus Carbide™ teeth

Dimensions			TPI	Recommended for Cutting	Pack of 5 Model No.	Price /Each
L" x W" x Thick"						
6 x 2 x 0.050			7	Hard cast iron, soil pipe	TCS920	109.00
9 x 2 x 0.050			7	and other thick metals	TCS921	139.00



THE TORCH™ SAWZALL® METAL-CUTTING BLADES

- Features a tooth form optimized for the longest life and maximum durability, as well as a stamped honeycomb pattern throughout the body of the blade to increase rigidity
- Material: Bi-Metal

Dimensions			TPI	Recommended for Cutting	Pack of 5 Model No.	Price /Each
L" x W" x Thick"						
9 x 1 x 0.042			18	Tough, straight cuts on metal	VF062	32.50



CUTTING TOOLS

THE TORCH™ WITH NITRUS CARBIDE™ SAWZALL® BLADE

- 3X longer life in cast iron than standard carbide blades
- 7 TPI design for fast cutting
- 1/2" universal tang
- 25% more Nitrus Carbide™ per tooth
- Ability to cut thick metals: stainless steel, black pipe, angle iron

Length"	TPI	Recommended for Cutting	Pack of 5 Model No.	Price /Each
12	7	Hard cast iron and soil pipe	UAK275	199.00



THE WRECKER™ SAWZALL® BLADE

- Nitrus Carbide™ Technology dissipates heat better than any other demolition blade
- Best blade for residential and demolition projects
- Lasts 2x longer than standard carbide teeth blades in woods, metals, and abrasives
- 6 TPI design for best material versatility
- Cuts through the widest variety of materials including wood with nails and screws, roofing material, plaster and drywall, and rigid conduit and black pipe
- Fang Tip™ design for fastest plunge cuts in woods, plaster and drywall
- Universal Tang: 1/2"

Dimensions			TPI	Qty /Pkg.	Model No.	Price /Each		
L"	W"	Thick"						
6	x	1	x	0.050	6	1	UAV616	24.50
6	x	1	x	0.050	6	3	UAV619	67.50
6	x	1	x	0.045	6	5	UAV622	135.00
9	x	1	x	0.050	6	1	UAV617	30.20
9	x	1	x	0.050	6	3	UAV620	86.30
9	x	1	x	0.050	6	5	UAV623	139.00
12	x	1	x	0.050	6	1	UAV618	38.50
12	x	1	x	0.050	6	3	UAV621	110.00
12	x	1	x	0.050	6	5	UAV624	219.00



THE TORCH™ SAWZALL® BLADES

- Optimized tooth design providing 2X more life than our previous generation
- Grid Iron™ honeycomb pattern increases blade rigidity to resist blade buckling
- Tough Neck™ ribs strengthen the blade tang and minimize breakage
- Metal-cutting blades with Double Duty Upgrade™ feature a tooth form optimized for the longest life and maximum durability
- Material: Bi-Metal

Dimensions			TPI	Recommended for Cutting	Pack of 5 Model No.	Price /Each		
L"	W"	Thick"						
6	x	1	x	0.042	14	Tough.	VF059	24.90
6	x	1	x	0.042	18	Straight Cuts	VF060	25.50
9	x	1	x	0.035	24	Tough.	TYE997	27.90
9	x	1	x	0.042	10	Straight Cuts	VF058	32.90
9	x	1	x	0.042	14	Cuts	VF061	32.50
12	x	1	x	0.042	14	Tough.	TB0898	38.50
12	x	1	x	0.042	18	Straight Cuts	VF063	37.90



SAWZALL® DEMOLITION BLADE SET

- Assortment of popular demolition blades for a broad range of professional applications
- No. of Pieces: 12
- Size Range: 6" - 9"

Model No. TYF991
Mfg. No. 49-22-3329
Price/Each \$52.50



NAILSLICER™ FRAMING CIRCULAR SAW BLADE

- High impact premium carbide teeth provide 8x blade life
- Active Shield™ protective blade coating allows 70% more cuts per charge
- Cordless and corded performance for maximum versatility
- Active Shield™ blade coating protects against heat for reduced gumming
- Laser cut expansion slots reduces blade warping
- Laser cut vibration slots minimize blade vibration for straighter cuts
- Diameter: 7-1/4"
- Arbor Size: 5/8"
- No. of Teeth: 24
- Application Type: Wood
- Tooth Grind: ATB
- Hook Angle: 18°
- Kerf: .063"
- Manufacturer's Warranty: Limited Lifetime Warranty
- Colour: Rawhide
- Finish: ActiveShield™

Model No. AUW192
Mfg. No. CSBFR-724
Price/Each \$13.50



JIG SAW BLADES

UNIFIED SHANK® JIG SAW BLADES

- Fits both universal shank and Bosch shank jig saw
- Made out of the exclusive bi-metal Unique® process technology that makes them resist breakage, cut faster and last longer than other blades

Dimensions L" x W" x Thick"	TPI	Tooth	Set	Pack of 5 Model No.	Price /Each	Pack of 20 Model No.	Price /Each
FOR WOOD CUTTING							
3 x 5/16 x 0.050	6	Ground	Tapered	EAM111	24.60	EAM115	96.30
3 x 5/16 x 0.050	6	Ground	Alternate	TGZ503	16.50	EAM116	62.10
3 x 5/16 x 0.050	8	Regular	Alternate	EAM112	13.90	EAM117	54.70
3 x 5/16 x 0.050	10	Ground	Tapered	TGZ501	18.50	EAM118	65.30
3 x 5/16 x 0.050	10	Ground	Tapered, downstroke cut	EAM113	16.60	EAM119	65.30
4 x 3/8 x 0.050	6	Skip	Alternate	EAM114	19.90	EAM120	78.00
FOR METAL CUTTING							
2 x 5/16 x 0.040	24	Wavy	Regular	EAM121	12.90	EAM125	50.70
2 x 5/16 x 0.040	32	Wavy	Regular	EAM122	15.50	EAM126	60.90
3 x 3/16 x 0.040	24	Wavy	Scroll	EAM123	15.00	EAM127	58.80
4 x 3/8 x 0.040	24	Wavy	Regular	EAM124	18.80	EAM128	73.70
MULTI-PURPOSE							
2 x 5/16 x 0.040	14	Wavy	Regular	-	-	EAM134	50.70
2 x 5/16 x 0.040	18	Wavy	Regular	EAM130	12.90	EAM135	50.70
2 x 5/16 x 0.040	14	Wavy	Scroll	EAM131	15.00	EAM136	58.80
2 x 3/16 x 0.040	10-14	Wavy	Varipitch	TGZ502	20.50	EAM137	74.60
4 x 3/8 x 0.040	18	Wavy	Regular	EAM132	14.30	EAM138	56.40



EAM111



EAM121



EAM130

UNIVERSAL-SHANK JIG-SAW BLADES

Bi-Metal - Super-tough bonded alloy steel for long life and faster cuts.

High-Carbon Steel - Tough durable carbon alloy blade for multi-purpose uses.

High-Speed Steel - General-purpose blade.

Sold in packs of 5



Length"	Width"	Teeth"	Tooth Type	Blade Material	Recommended Use	Model No.	Price /Each
GENERAL PURPOSE							
4	9/32	6	Milled and set	Bi-metal	Fast cutting, nail-embedded wood	TT427	20.50
4	9/32	10	Milled and set	Bi-metal	Fast cutting, nail-embedded wood	TT428	20.50
4	9/32	8	Milled and set	High-carbon steel	Fast straight-cutting wood	TT431	12.50
WOOD CUTTING							
4	9/32	10	Taper ground	Bi-metal	Fast clean cutting	TT436	26.50
23/4	3/16	20	Taper ground	Bi-metal	Scroll cutting in wood and laminates	TT437	26.50
4	9/32	6	Ground and set	High-carbon steel	Very fast rough cutting	TT438	23.90
4	9/32	6	Taper ground	High-carbon steel	Very fast clean cutting	TT439	14.50
3 1/8	7/32	8	Taper ground	High-carbon steel	Clean cutting	TT441	14.50
4	9/32	10	Taper ground	High-carbon steel	Straight clean cutting	TT442	14.50
4	9/32	10	Taper ground	High-carbon steel	Reverse, no top splinters	TT443	17.30
23/4	5/32	12	Milled, wavy set	High-carbon steel	Clean scroll cutting	TT444	11.50
METAL CUTTING							
3 5/8	9/32	14	Milled, wavy set	Bi-metal	Thick over 1/4" thick	TT456	17.90
2 3/4	9/32	18	Milled, wavy set	Bi-metal	Metal over 1/8" thick	TT458	18.50
2 3/4	9/32	24	Milled, wavy set	Bi-metal	Metal under 1/8" thick	TT459	18.50
2 3/4	9/32	14	Milled, raker set	High-speed steel	Metal over 1/4" thick	TT461	13.50
2 3/4	9/32	18	Milled, wavy set	High-speed steel	Metal over 1/8" thick	TT462	13.50
2 3/4	9/32	24	Milled, wavy set	High-speed steel	Metal under 1/8" thick	TT463	13.50

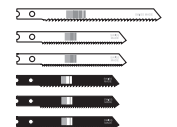
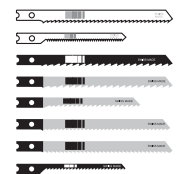



SAFETY TIP

To assure material compatibility, test product on a small inconspicuous area or similar expendable component prior to use. Do not use on energized electrical equipment or equipment in operation and allow surface to dry before restart.

G-49™ LOW VOC ORANGE DEGREASER

- Complies with CARB/OTC/LADCO (California Air Resources Board/Ozone Transport Commission/Lake Michigan Air Directors Consortium) VOC regulations
- Instant cleaning action, no residue
- High solvent strength
- Moderate evaporation
- Not a hazardous air pollutant (HAP)
- Ideal for cleaning metals
- Inverta spray valve can be sprayed at almost any angle
- NSF registered category code C1



Model No.	Mfg. No.	Size	Price /Each
AD186	C06420	15 oz.	35.50

T-91 NON-SOLVENT DEGREASER

- Zero VOC's, biodegradable
- Non-flammable, non-toxic, low odour
- Safe on metals
- Non-dilutable – Must be used straight
- Moderate foam for effective mechanical cleaning
- Ideal for traditional solvent cleaning, basin style part washers and dip tanks
- NSF registered category code A1
- Accepted for use in Canadian food processing facilities



Model No.	Mfg. No.	Size	Price /Each
AD295	C06328	28 oz.	30.50
AD183	C06301	1 gal.	105.00
AD185	C06355	55 gal.	3395.00

A-151 SOLVENT DEGREASER

- High flash point above 140°F (60°C)
- Low odour
- No rinsing and no residue
- Non-conductive
- Safe to use on most surfaces
- NSF registered category code C1



Model No.	Mfg. No.	Size	Price /Each
AA920	C04320	15 oz.	42.50
AB448	C04305	5 gal.	1015.00
AB579	C04355	55 gal.	8159.00

EVR® CLEAN AIR SOLVENT DEGREASER

- High solvent strength, fast evaporating, low VOC content
- Not a Hazard Air Pollutant (HAP)
- Instant cleaning action
- Ideal for cleaning metals
- No residue or ozone depleting compounds
- Inverta spray valve allows can to be sprayed at almost any angle
- NSF registered category code C1



Model No.	Mfg. No.	Size	Price /Each
AD060	C05220	14 oz.	26.90
AD063	C05255	55 gal.	3635.00

HDX HEAVY-DUTY DEGREASER

- Low odour
- Quick penetration
- No rinsing
- No residue
- Non-conductive
- Heavy-duty action removes oil, grease, wax, dirt, moisture, tar, brake fluid and other contaminants
- NSF registered category code K1



Model No.	Mfg. No.	Size	Price /Each
AA840	C01020	19 oz.	22.50
AB446	C01005	5 gal.	825.00

PRESOLVE® ORANGE DEGREASER

- High performance cleaner
- Non-conductive
- Natural-based solvent
- No rinsing and no residue
- Fast acting, deep penetration
- Safe on all metals and most plastics
- NSF registered category code C1



Model No.	Mfg. No.	Size	Price /Each
AA786	C01420	15 oz.	37.50
AD729	C01422	20 oz. Trigger	45.90
AB604	C01428	1 gal.	199.00
AB603	C01405	5 gal.	925.00
AA868	C01455	55 gal.	8089.00

F-104° SOLVENT DEGREASER

- 104°F (40°C) flash point
- Rapid evaporation
- Non-conductive
- No rinsing
- Heavy-duty cleaner/degreaser
- Safe to use on most surfaces - may be harmful to some plastics



Model No.	Mfg. No.	Size	Price /Each
AA919	C04920	15 oz.	29.90
AB591	C04955	55 gal.	4269.00

ZEROTRI® HEAVY-DUTY DEGREASER

- Instant degreasing action
- Ideal for degreasing metals
- No rinsing and no residue
- Safe to use on most surfaces
- Excellent alternative to Methyl Ethyl Ketone (MEK)
- Accepted for use in Canadian food processing facilities



Model No.	Mfg. No.	Size	Price /Each
AA787	C03520	15 oz.	44.50
AB607	C03528	1 gal.	285.00
AB605	C03505	5 gal.	1259.00
AB606	C03555	55 gal.	9015.00

HEAVY DUTY DEGREASER

- Base Type: Chlorinated
- No flashpoint
- Fast evaporation rate
- A versatile cleaner/degreaser that is extremely effective in most heavy duty applications
- Aggressively dissolves grease, oil and sludge for more efficient operation of mechanical equipment
- NSF Registered K1
- Accepted for use in Canadian food processing facilities



Model No.	Mfg. No.	Size	Price /Each
YA184	73095	539 g	20.90

DETEX® FOODLUBE® SUGAR DISSOLVING FLUID

- Rapidly dissolves and removes sugar-based soils, keeping food and beverage equipment fully operational
- NSF H1 lubricant can be used anywhere within a facility where incidental food contact may occur
- Release agent eases future cleaning of sticky soils
- Provides short-term corrosion protection on exposed metal surfaces
- Metal and X-ray detectable packaging
- Accepted for use in Canadian food processing facilities



Model No.	Mfg. No.	Size	Price /Each
AH204	C57728	828 ml	52.50
AH205	C57701	1 gal.	155.00

SLAP SHOT™ CLEANER/DEGREASER

- Industrial parts cleaner/degreaser
- Removes grease and oil
- Free of chlorinated solvent
- Safe on all metals
- Prepares surfaces for painting or relubrication
- Requires no rinsing, leaves no residues



Model No.	Mfg. No.	Size	Price /Each
YC419	53-C-502	500 ml	14.90
AC306	53-C-503	500 ml, trigger	26.50
AA462	53-C-506	5 L	125.00
AA463	53-C-507	20 L	479.00
AC307	53-C-508	200 L	2605.00

BFX ALL-PURPOSE CLEANER

- Water-based
- Butyl-free and dye-free formula
- Removes grease and oil
- Rinses clean
- Ideal for parts washers and pressure washers
- Safe on most surfaces except magnesium
- NSF registered category code C1



Model No.	Mfg. No.	Size	Price /Each
AB581	C05528	28 oz.	23.50
AB583	C05555	55 gal.	2215.00

GREZ-OFF DEGREASER

- Professional strength, biodegradable formula hits hard and fast with powerful water-soluble solvents
- Quickly breaks down heavy grease, oil, tar, lubricants and grime
- Safe on metal, plastic, vinyl, rubber, and fiberglass



Model No.	Mfg. No.	Size	Price /Each
NJQ185	C12532	946 ml	13.90
JK738	C12501	4 L	37.90
JK739	C12520	20 L	179.00
JK740	C12545	208 L	1369.00

T-FORCE™ DEGREASER

- High-performance industrial strength degreaser
- Non-conductive, non-corrosive, and non-staining
- No flash point
- No fire point
- NSF Registered K1



Model No.	Mfg. No.	Size	Price /Each
AF205	73115	510 g	49.50

HYDROFORCE® ZERO VOC GENERAL PURPOSE CLEANERS

- Plastic safe: Yes
- Slow evaporation rate
- Provides maximum regulatory compliance without performance compromises
- Removes dirt, dust, and grime
- Accepted for use in Canadian food processing facilities
- NSF Registered A1



Model No.	Mfg. No.	Size	Price /Each
AE970	74446	946 ml	28.50

INSTANT SUPER DEGREASER 2.0

- Non-flammable fast drying solvent degreaser
- Heavy-duty formula that removes oil, grease, dirt, and tar with less cleaner
- Non-brominated formula that improves worker safety and simplifies employer compliance
- No residue/no rinsing formula
- Non-conductive formula that can be used on or near energized equipment, eliminating equipment downtime



Model No.	Mfg. No.	Size	Price /Each
AF141	C07220	20 oz.	64.50

EFX SOLVENT /DEGREASER

- Heavy-duty solvent
- Instant degreasing action, quickly removes grease and oil
- Power blast spray
- Fast evaporating, no residue, non-chlorinated
- Safe to use on most surfaces
- Ideal for cleaning metals and most plastics



Model No.	Mfg. No.	Size	Price /Each
AD833	C01820	15 oz.	21.90

MULTI-PURPOSE SOLVENT

- Excellent choice for many applications
- Effective for degreasing machine shop tools and equipment; cleaning most hard surfaces and prepping project stations; and for removing tough stains without damage to the surface



Model No.	Mfg. No.	Size	Price /Each
AH181	53-228	18.9 L	129.00

CHEMICALS

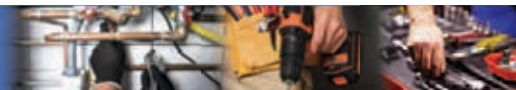

UNO S F CLEANER

- Non-flammable
- Concentrated cleaning power
- Contains corrosion inhibitors
- Solvent, phosphate and butyl-free
- For iron, steel, and stainless steel
- Removes oil, fat, grease, soot, wax and protein
- VOC free
- Accepted for use in Canadian food processing facilities



Model No.	Mfg. No.	Size	Price /Each
AA464	53-G 023	500 ml trigger	11.90
AA466	53-G 017	20 L	145.00
NI137	53-G 018	200 L	1689.00

CB 100™ NATURAL WATER-BASED SOLVENT

- All-natural, water-based cleaner and degreaser
- Offers superior cleaning results with the removal of stubborn ink, rubber marks, tar, wax, carbon, soot, pastes and many other common industrial contaminants
- Bio-degradable, VOC free, non-flammable
- Safe on steel, stainless steel, aluminum and non-ferrous metals
- Applications: Immersion bath, pressure washing, all manual cleaning operations



Model No.	Mfg. No.	Size	Price /Each
AD515	53G167	20 L	195.00

SP705 NON-CHLORINATED BRAKE & PARTS CLEANER

- Non-chlorinated and fast evaporating
- Leaves no residue
- Instantly flushes away brake fluids, grease and dirt to ensure accurate adjustments and smooth brake operations
- Also recommended as a cleaner for metal parts
- Improves brake performance, helps stop break disc squeal



Model No.	Mfg. No.	Size	Price /Each
AA649	SC0705000	14 oz.	12.60

CD885 STAINLESS STEEL CLEANER

- Water-based emulsion
- Effectively cleans most water and oil-based stain on stainless steel and other metal surfaces
- Resists finger-prints, water marks and rusting
- USDA compliant, NSF Certified



Model No.	Mfg. No.	Size	Price /Each
AA202	SC0885000	17 oz.	14.60

CD880 GENERAL PURPOSE CLEANER

- All-purpose formula cuts through dirt with ease
- Safe to use on metal, finished wood, porcelain, vinyl, leather, laminated surfaces and glass
- Cleans spots on synthetic carpets
- USDA compliant, NSF Certified



Model No.	Mfg. No.	Size	Price /Each
AA200	SC0880000	19 oz.	12.50

CD888 GLASS CLEANER

- Removes soil, smoke haze, fingerprints, road film and surface smears
- Cleans any surface not normally harmed by water
- USDA compliant, NSF Certified
- Will not cloud plexiglas or other plastic materials
- Resists streaking; wipes clean



Model No.	Mfg. No.	Size	Price /Each
AA201	A00888	18 oz.	11.60

TRIFREE BRAKE CLEANER

- Heavy-duty performance
- Improves brake performance
- Helps stop disc brake squeal
- Fast evaporation
- Powerful jet spray
- No rinsing and no residue



Model No.	Mfg. No.	Size	Price /Each
AA818	C03620	15 oz.	36.90

CD887 COIL CLEANER

- Water-based, foaming coil cleaner
- Foaming and penetrating action
- Non-flammable and non-corrosive
- Safe on all types of metal
- Recommended use: All refrigerator and A/C coils, coolers, freezer engines, HVAC units, motors and machinery



Model No.	Mfg. No.	Size	Price /Each
AD056	SC0887000	18 oz.	12.60

CHLOR-FREE™ DEGREASER

- Non-chlorinated degreasing solvent that removes oil, grease and other types of contaminants
- Ideal for use in applications requiring quick turnaround and where a low flashpoint solvent can be used
- NSF Registered K2



Model No.	Mfg. No.	Size	Price /Each
AF105	73185	425 g	17.50

SUPER CITRUS™ DEGREASERS

- Base type: d-Limonene and petroleum distillate
- Flashpoint: 43°C
- Fast evaporation rate
- Removes grease, oil and lubricants with no water wash-off
- Evaporates quickly and leaves no residue
- Pleasant citrus scent
- NSF Registered C1



Model No.	Mfg. No.	Size	Price /Each
AE967	73170	425 g	23.90

CITRUS BASE CLEANER

- Heavy-duty degreaser/cleaner
- Safe on metals, ceramic, glass, porcelain and many plastics
- Removes grease, oil, ink and most adhesives
- No harmful solvents
- Cleans without streaking
- Non-aerosol pump



Model No.	Size	Price /Each
QN488	18.5 oz.	62.42

WORKPLACE HAND CLEANER TOWELS

- Waterless hand cleaner
- Deep cleaning, non-scratching abrasives
- Leaves hands clean, conditioned and softened
- 72 towels per bucket



Model No.	Mfg. No.	Price /Each
AA841	C09200	43.50

GRAFFITI REMOVER GEL

- Easy-to-use with a superior blend of solvents
- Works on oil based marks
- Removes crayon, lipstick and spray paint
- Gel clings to vertical surfaces



Model No.	Mfg. No.	Size	Price /Each
JP339	1000010419	20 oz.	11.90

NOFLASH® 2.0 ELECTRO CONTACT CLEANERS

- Non-flammable fast drying electronic cleaner
- Industrial-strength formula for maximum cleaning power
- Non-brominated formula that improves worker safety and simplifies employer compliance
- No residue/no rinsing formula
- Non-conductive formula
- Inverta spray valve allows users to spray in an upright or inverted position for more convenient application



Model No.	Mfg. No.	Size	Price /Each
AF142	C07416	12 oz.	73.50

EL848 FLASH FREE SAFETY SOLVENT & DEGREASER

- Fast-acting solvent penetrates easily, evaporates quickly, leaves no residue
- Ideal for removing grease, dirt, wax and metallic particles
- Non-conductive
- Non-flammable
- Dielectric strength: 37 000 volts
- Includes extension tube and high-delivery nozzle for flush-type applications
- NSF registered category code K2



Model No.	Mfg. No.	Size	Price /Each
AA216	SC0848000	13 oz.	23.00

EL2302 ELECTRONIC CONTACT CLEANER

- Heavy-duty degreaser and quick-drying cleaner
- Ideal for sensitive equipment and precision instruments
- Fast-evaporating
- Safe on most plastics
- Leaves no residue
- For use on non-energized equipment
- For printed circuits, office machines, vacuum tube parts and computer systems
- NSF Registered K2



Model No.	Mfg. No.	Size	Price /Each
AA214	SC2302000	11 oz.	27.60

EL749 ELECTRICAL DEGREASER

- Designed for fast, effective removal of dirt, oil, grease, wax and tar on electrical equipment
- For use on non-energized equipment
- Leaves no residue
- Fast-evaporating
- For electric motors, radar equipment, gears, brakes, clutches, generators, air tools and moulds



Model No.	Mfg. No.	Size	Price /Each
NA613	SC0749000	15 oz.	23.40

SP610 ANTI-STATIC SPRAY

- Neutralizes static electricity generated by friction or atmospheric conditions
- Proven effective on plastic, paper, cellophane, cloth and thread materials
- Dries instantly, non-staining
- Can be applied to machinery or parts in process
- Will not attract contaminants



Model No.	Mfg. No.	Size	Price /Each
AC517	SC0610000	11.5 oz.	28.00

CHEMICALS



CFC FREE ELECTRO CONTACT CLEANER

- Fast evaporation
- No residue
- Low odour
- Non-conductive
- Safe on plastics
- Inverta spray valve allows you to spray in an upright or inverted position
- NSF registered category code K2



Model No.	Mfg. No.	Size	Price /Each
AA784	C03116	11 oz.	41.50
AB546	C03101	1 gal.	199.00
AB544	C03105	5 gal.	825.00
AB545	C03155	55 gal.	8279.00

CFC FREE NU CONTACT CLEANER

- Reduced VOC's (Volatile Organic Compounds) content and conforms to CARB (California Air Resources Board), OTC (Ozone Transport Commission) and LADCO (Lake Michigan Air Directors Consortium) VOC regulations
- Removes dirt, flux, moisture, dust, and other contaminants from electrical equipment
- Fast evaporating, safe on plastics
- Will not leave a residue
- NSF registered category code K2



Model No.	Mfg. No.	Size	Price /Each
AD177	C05416	11 oz.	48.50

REVO 66® CONTACT CLEANER

- Ideal for removing dirt, moisture, flux or oxides from the internal components of electronic equipment
- Non-flammable precision cleaning
- Does not contain brominated solvents
- Fast evaporating
- Non-conductive
- Quick penetration
- No rinsing and no residue
- Safe to use on most surfaces
- NSF registered category code K2
- Accepted for use in Canadian food processing facilities



Model No.	Mfg. No.	Size	Price /Each
AD010	C04416	12 oz.	72.50

ELECTRO 140° CONTACT CLEANER

- Flash point above 140°F (60°C)
- Superior wetting and penetrating action
- Controlled evaporation
- No residue
- Non-conductive
- Safe to use on most surfaces
- Inverta spray valve allows you to spray in an upright or inverted position



Model No.	Mfg. No.	Size	Price /Each
AA836	C00916	11 oz.	34.90

ELECTRO CONTACT CLEANER

- No ozone depletion potential
- Fast penetration
- Quick evaporation
- Penetrates into minute spaces
- Cleans/degreases delicate mechanisms
- Ideal for electrical/electronic fine parts
- Removes light greases, oils, dirt and organic soils
- No rinsing and no residue
- Safe to use on most surfaces



Model No.	Mfg. No.	Size	Price /Each
AA858	C00416	14 oz.	149.00

MICRO-X FAST EVAPORATING CONTACT CLEANER

- Fast evaporation
- Quick penetration
- No residue
- Low odour
- Safe on plastics
- No rinsing
- Inverta spray valve allows you to spray in an upright or inverted position



Model No.	Mfg. No.	Size	Price /Each
AA837	C04516	11 oz.	26.50

QB PRECISION DUSTER

- Quick blast precision duster removes contaminants, dirt, dust and other soils
- Moisture free
- No residue
- No flash point
- Odourless



Model No.	Mfg. No.	Size	Price /Each
AA918	C05710	12 oz.	63.90

PSC PLASTIC SAFE CLEANER

- Formulated for contact cleaning
- Fast evaporation
- No flash point
- No rinsing and no residue
- Displaces moisture
- Very low odor
- No CFC's



Model No.	Mfg. No.	Size	Price /Each
AB700	C04620	18 oz.	165.00

LECTRA CLEAN® HEAVY-DUTY ELECTRICAL PARTS DEGREASER

- A chlorinated based degreaser that quickly removes grease, oil and dirt from motor parts and other similar equipment
- NSF Registered K2



Model No.	Mfg. No.	Size	Price /Each
AF103	72018	539 g	18.50

QD™ CONTACT CLEANER

- Plastic safe: Yes
- Flashpoint: Less than -18°C
- Very fast evaporation rate
- Suitable for cleaning sensitive electronics and electrical equipment
- Use where lower flashpoint cleaners are acceptable
- Accepted for use in Canadian food processing facilities
- NSF Registered K2



Model No.	Mfg. No.	Size	Price /Each
MLN874	72130	312 g	27.90

FREEZE SPRAY

- Plastic Safe: Yes
- No flashpoint
- Very fast evaporation rate
- Aerosol coolant system that instantly freezes surfaces to -60°F, dissipating heat and cooling equipment
- Assists in locating thermal intermittent components, failures and shorts
- Safe to use on sensitive components and all surfaces finishes



Model No.	Mfg. No.	Size	Price /Each
AE971	74086	284 g	37.90

SILICONE LUBRICANT

- Safely lubricates, waterproofs and protects metal and non-metal surfaces, including rubber, plastic and vinyl
- Dries fast and leaves a clear, non-staining film that doesn't stick or make a mess
- Ideal for use on cables, pulleys, guide rails, valves, linkages, hinges, locks and more
- Container Type: Aerosol Can
- Effective Temperature Range: -100°F to 500°F
- Film Type: Dry



Model No.	Mfg. No.	Size	Price /Each
AH410	01279	311 g	14.30

LPS 1® GREASELESS LUBRICANT

- Dry, thin lubricating film
- Resists oil, dust and dirt build-up
- Fast acting penetration
- Displaces moisture
- Loosens rusted or frozen parts
- Provides short term, light, corrosion resistant barrier
- Safe on paint and most plastics
- Inverta spray valve lets you spray in all directions
- NSF registered category code H2
- Accepted for use in Canadian food processing facilities



Model No.	Mfg. No.	Size	Price /Each
AA819	C30116	11 oz.	28.90
AB628	C00122	20 oz. trigger	37.90
AB627	C01128	1 gal.	115.00
AB625	C00105	5 gal.	495.00
AB626	C00155	55 gal.	4705.00

HEAVY-DUTY SILICONE LUBRICANT



- Silicone-rich formula
- Water-based formula
- Colourless and odourless
- Excellent lubricity
- Eliminates sticking, binding and squeaking
- Dry, non-staining
- Safe on most surfaces
- Made of FDA compliant materials
- NSF registered category code H1
- Accepted for use in Canadian food processing facilities



Model No.	Mfg. No.	Size	Price /Each
AB624	C01505	5 gal.	679.00

LPS 2® HEAVY-DUTY LUBRICANT



- Added corrosion protection
- Provides a nondrying, light, oily film for use on indoor /outdoor equipment
- Reduces wear caused by friction and corrosion
- Displaces moisture
- Loosens rusted or frozen parts
- Provides up to one year of protection
- Safe on paint and most plastics
- Inverta spray valve lets you spray in all directions
- NSF registered category code H2
- Accepted for use in Canadian food processing facilities



Model No.	Mfg. No.	Size	Price /Each
AA820	C30216	11 oz.	28.50
AB632	C00222	20 oz. trigger	37.90
AB631	C02128	1 gal.	139.00
AB629	C00205	5 gal.	479.00
AB630	C00255	55 gal.	5119.00

LU1324 HIGH PERFORMANCE SILICONE LUBRICANT

- 6.6% silicone formula
- Stops squeaks and sticking, eliminates friction, displaces water, inhibits rust and prevents freezing
- Does not harden or degrade from -40°F to 400°F
- Apply to wood, metal, fabric, rubber or leather
- Keeps rubber soft and flexible
- For rubber mountings, weather-strip insulation, doors, locks, trunk lids, windows, slitter knives, any sliding surface



Model No.	Mfg. No.	Size	Price /Each
AA647	SC1324000	10 oz.	14.60

FOOD PLANT SILICONE LUBRICANT

- Flashpoint: Less than -18°C
- Fast evaporation rate
- Multi-purpose silicone spray for food processing and handling applications
- Forms a colorless, odorless, non-staining film
- Eliminates binding and sticking in most metal to non-metal applications
- Accepted for use in Canadian food processing facilities
- NSF Registered H1



Model No.	Mfg. No.	Size	Price /Each
YC014	73040	284 g	23.90

DRY GRAPHITE LUBRICANT

- Dry black film
- Flashpoint: Less than -18°C
- Fast evaporation rate
- Resists dirt, dust and oil build-up
- Wide effective temperature range up to 454°C constant



Model No.	Mfg. No.	Size	Price /Each
MLT431	75101	320 g	17.90

LU206 ALL-PURPOSE SILICONE LUBRICANT

- 5% silicone formula
- Reduces friction and sticking; protects against corrosion and oxidation with an invisible film that repels water
- Compatible with most surfaces; will not attack most plastics
- Will not interfere with painting or decorating
- Effective from -50°F to 375°F
- For rubber moldings, windows, sliding wood surfaces, sewing equipment, sliding racks, dissimilar metals, springs, leather, doors, hinges, weather-stripping, plastic assemblies



Model No.	Mfg. No.	Size	Price /Each
AA108	SC0206000	10 oz.	13.00

SILICONE LUBRICANT

- Lubricates cutting tools and tables
- Prevents build-up of glues, wax, inks, paints
- Fast drying, long lasting, high quality
- Eliminates squeaks and sticking
- Contains no petroleum oils to stain fabrics
- Helps preserve plastic, rubber and leather



Model No.	Mfg. No.	Size	Price /Each
AG904	SILICONE-13	13.25 oz.	25.98

EZ-REACH MULTI-USE PRODUCT

- Safeguards metal against rust and corrosion, penetrates stuck parts, repels moisture and lubricates almost everything
- Eliminates grease, dirt and more from most surfaces
- New flexible 18cm long tube can be folded and maintained in the desired shape
- With multiposition spray from a flexible tube, combined with a 360° valve, the product can be used upright or upside down, allowing wide or precise spray in spaces that were inaccessible
- More durable metal tube: doesn't melt
- Recommended for unblocking clutch nuts behind the engine block, lubricating hard-to-reach engine valves, facilitating plumbing work in tight places, and making pipe jointing easier under sinks and bathtubs
- Container Type: Aerosol Can



Model No.	Mfg. No.	Size	Price /Each
AH374	01077	408 g	22.90

CHEMICALS



LU204 DRY FILM GRAPHITE LUBRICANT

- Ideal where a dry lubricant is or where petroleum products must be avoided
- Adheres with minimum pre-treatment
- Effective up to 850°F constant and 1000°F intermittent
- Dries rapidly at room temperature
- For pre-assembly lubrication of moving parts, mechanisms of vending machines and parking meters, automotive and industrial gaskets, bearings, locks, springs, hinges, mating surfaces on machines, CRT's, plating non-conductors, curing ovens



Model No.	Mfg. No.	Size	Price /Each
AA107	SC0204000	10 oz.	19.00

DRY FILM SILICONE LUBRICANT

- Colourless, thin film
- Excellent for releasing moulded parts in high temperatures or pressures
- Low odour
- Non-staining
- Non-flammable
- Non-corrosive



Model No.	Mfg. No.	Size	Price /Each
AA902	C01616	11 oz.	30.50

LU708 HIGH PERFORMANCE DRY LUBRICANT

- Dry, non-oily, non-staining lubricant
- Made with DuPont® Krytox®
- Dries quickly to a white, chemically inert film
- Effective from -40°F to 572°F
- Resists most solvents
- For metal extrusions, munitions, locks and catches, window guides, synthetic fibers, machine parts, cord, twine or rope, leather drawers, hinges, paper, glass, elastomers and some plastics
- Use as release agent on conveyor belts, chutes and slides, industrial blenders, tanks, bins and spray booths



Model No.	Mfg. No.	Size	Price /Each
AA184	SC0708000	10 oz.	23.00

DETEX® HEAVY DUTY SILICONE LUBRICANT

- A silicone-rich, water-based lubricant that eliminates sticking, binding, and squeaking while protecting rubber and plastic parts
- NSF H1 lubricant can be used anywhere within a facility where incidental food contact may occur
- Safe on most surfaces, including rubber and plastics
- Odourless formula reduces potential transference to foods
- Colourless lubricant will not stain production equipment
- Metal and X-ray detectable packaging
- Accepted for use in Canadian food processing facilities



Model No.	Mfg. No.	Size	Price /Each
AH203	C51516	369 g	28.90

DETEX® FOOD GRADE SILICONE LUBRICANT

- Anti-stick agent for chutes and slides to keep packages moving
- NSF H1 lubricant can be used anywhere within a facility where incidental food contact may occur
- Dry film will not attract dust or dirt
- Safe on all metals, plastics, and rubber part
- Colourless formula will not stain packaging material or equipment
- Metal and X-ray detectable packaging
- Accepted for use in Canadian food processing facilities



Model No.	Mfg. No.	Size	Price /Each
AH211	C01716	284 g	17.50

LU200 DRY MOLY LUBRICANT

- Penetrates pores of substrate and bonds to surface for long-lasting lubrication
- High-pressure, high-solids molybdenum disulfide coating
- Withstands pressures up to 50 000 PSI
- Air dries in 5-10 minutes; cures in 2 hours at room temperature
- Maintains effectiveness under high temperatures (650°F constant and 750°F intermittent)
- For assembly and run-in lubrication, automotive and industrial gaskets, sliding surfaces and gears, chutes and bins, bearings, chain drives, intricate mechanisms, vending machines, parking meters, roller chains, conveyor belts where heat is present



Model No.	Mfg. No.	Size	Price /Each
AA104	SC0200000	11 oz.	18.60

FORCE 842® DRY MOLY LUBRICANT

- Works under high temperatures up to 842°F (450°C) and pressures up to 100 000 PSI (6890 bars)
- Prevents seizure of parts
- High adhesion
- Resists dust and dirt
- Water and chemical resistant
- Provides a quick drying, thin film
- Not recommended for friction bearings or light-duty bearings



Model No.	Mfg. No.	Size	Price /Each
AA845	C02516	11 oz.	45.50

MAGNUM PREMIUM LUBRICANT WITH PTFE

- High performance lubricant with PTFE additives
- Ultra high lubricity
- Penetrates and protects metal against rust and corrosion
- Flash point of 175°F (79°C)
- Displaces moisture
- Safe to use on most surfaces
- Inverta Spray Valve lets you spray in all directions
- NSF registered category code H2



Model No.	Mfg. No.	Size	Price /Each
AA842	C00616	11 oz.	33.50

POWER LUBE W/PTFE

- Maximum Working Temperature: 300°F (148.9°C)
- Contains PTFE for long-lasting lubrication and protection
- High performance
- NSF Registered H2



Model No.	Mfg. No.	Size	Price /Each
AF239	73045	312 g	18.50

FOOD PLANT PENETRATING OIL

- General purpose lubricant for use on food processing equipment
- Penetrates and loosens rust, scale, corrosion, and dirt to free corroded parts and fasteners
- Does not contain silicones
- Approved for use in Canadian food processing facilities
- NSF Registered H1



Model No.	Mfg. No.	Size	Price /Each
AF203	73086	312 g	13.90

FOOD PLANT CHAIN LUBE

- Keeps roller drive and conveyor chains lubricated
- Blend of synthetic lubricants and mineral oil
- Penetrates, lubricates and protects moving parts by reducing friction and wear
- Approved for use in Canadian food processing facilities
- NSF Registered H1



Model No.	Mfg. No.	Size	Price /Each
AF201	73056	340 g	23.90

DI-ELECTRIC GREASE

- Non-curing silicone compound used for electrical sealing
- Waterproofs electrical connections and components
- Improves electrical performance
- NSF Registered H1



Model No.	Mfg. No.	Size	Price /Each
AF248	73082	284 g	37.90

DETEX® FOOD GRADE EXTREME TEMP GREASE

- Premium, fully synthetic grease performs well in extreme temperature applications (-75°F - 510°F)
- NSF H1 grease can be used anywhere within a facility where incidental food contact may occur
- Non-melting formula is suitable for extended high temperature exposures
- Dye-free grease will not stain product or equipment
- Fortified with PTFE for enhanced lubrication and corrosion resistance
- Resists water washout through multiple wash cycles
- Metal and X-ray detectable plastic cap
- Accepted for use in Canadian food processing facilities



Model No.	Mfg. No.	Size	Price /Each
AH206	CS1014	369 g	67.50
AH207	CS1055	55 Gal.	19185.00

CLEAR PENETRATING GREASE

- Features high tack, quick penetrating action, metal detectable plastic components, and clear lubricating gel
- High performance, versatile lubricant fortified with PTFE additives for enhanced lubrication
- Resists water washout
- Protects against corrosion
- Colour: Beige
- Odour: Acetone
- Appearance: Gas
- Boiling Point/Range: 132.8 °F (56 °C)
- Flash Point: 132.8 °F (56.0 °C)
- Tag Closed Cup
- Vapor Density: 2
- Viscosity: 260 cP @ 75°F (Concentrate)
- Heat of Combustion: > 30 kJ/g
- Temperature Range: 0°F (-18°C) to 400°F (204°C)

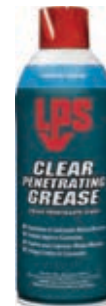

Model No.	Mfg. No.	Size	Price /Each
AH202	CO6716	11 oz.	30.50

MULTI-PURPOSE FOOD PLANT GREASE

- Appearance: White Semi-Solid/Solid Grease
- Effective Temperature Range: -5°F - 370°F (-20.6°C to 187.8°C)
- Base Type: Aluminum Complex
- Flash Point: 221°C
- NSF Registered H1



Model No.	Mfg. No.	Size	Price /Each
AF202	73600	397 g	17.90

DETEX® FOOD GRADE ELECTRONIC CLEANER

- Removes dirt, moisture, and oxides from electronic equipment
- NSF K6 electronic cleaner can be used anywhere within a facility where incidental food contact may occur
- Plastic-safe formula can be used on a variety of surfaces
- Fast drying and residue-free for efficient maintenance cycles
- VOC Compliant in all 50 states
- Metal and X-ray detectable packaging



Model No.	Mfg. No.	Size	Price /Each
AH215	CS8116	312 g	38.50

LU210 FOOD GRADE SILICONE LUBRICANT

- 5% silicone formula
- Colourless, odourless low-viscosity lubricant
- Prevents sticking without transferring to end products
- Will not attack delicate surfaces such as styrene or urethane
- For slides, guide rails, knives, slicers, saws, grinders, dough mixers, guards, conveyors, food racks, ovens, bottling machines, heat sealing equipment, all food and drug processing equipment
- NSF registered category code H1



Model No.	Mfg. No.	Size	Price /Each
AA110	SC0210000	10 oz.	12.60

SYNTHETIC FOOD GRADE OIL

- Includes PTFE for added lubricity
- Does not emulsify with water
- Waterproof
- Biodegradable
- Clear, non-staining
- Kosher approved
- For pumps, gear boxes, bearings, hydraulic systems, motors, chains, conveyors, general purpose lubrication
- NSF registered category code H1



Model No.	Mfg. No.	Size	Price /Each
AA525	TF23010	12 oz.	29.50

CHEMICALS



DETEX® FOOD GRADE MACHINE OIL

- Versatile lubricant eliminates sticking, binding, and squeaking
- NSF H1 lubricant can be used anywhere within a facility where incidental food contact may occur
- Oily film penetrates to loosen frozen nuts and bolts
- Colourless formula will not stain product or equipment
- Safe on all metal surfaces
- Metal and X-ray detectable packaging
- Accepted for use in Canadian food processing facilities



Model No.	Mfg. No.	Size	Price /Each
AH209	C01316	312 g	19.90

LU700 FOOD GRADE MACHINERY OIL

- Economical, general-purpose lubricant
- Penetrates and loosens rust, dirt, scale and corrosion
- Non-silicone formula is excellent for use in areas where silicone overspray might interfere with carton sealing or capping operations
- Virtually odourless, tasteless and colourless
- For bottle and carton filling machinery, valves, pistons, rollers, stainless steel pumps, chain drive belts, paste and sauce fillers, cams on rotary-type fillers, mixers, conveyors
- NSF registered category code H1



Model No.	Mfg. No.	Size	Price /Each
AA139	SC0700000	10 oz.	20.30

CHAINMATE® CHAIN & WIRE ROPE LUBRICANT

- Effective under extreme temperature and pressure ranges
- Fortified with molybdenum disulfide
- Deep penetration to the core of wire ropes
- High adhesion
- Lubricant and corrosion protectant
- Use with guards in place to eliminate costly down time
- Increases chain and wire rope life
- Reduces wear caused by friction and corrosion



Model No.	Mfg. No.	Size	Price /Each
AA877	C02416	11 oz.	35.50

LU202 MOLY CHAIN LUBRICANT

- Foaming action penetrates close tolerances of chain drive bushings and pins
- Specially formulated for all chain drive equipment
- Reduces wear, increases chain life up to three times when applied regularly
- Moly additive assures lubrication under extreme pressure
- Effective from -20°F to 300°F
- Excellent as a protective coating for stored metal parts
- For chain drives and pins, forklift trucks, tractors, machinery, workstand rollers, conveyors, motorcycle and bicycle chains, sprockets, clippers, cutter bars, chain saws, link and roller assemblies
- NSF registered category code H2



Model No.	Mfg. No.	Size	Price /Each
AA106	SC0202000	11 oz.	14.60

DRY FILM PTFE LUBRICANT

- Ideal for releasing moulded parts
- Excellent for high temperature applications up to 500°F (260°C)
- Dry, thin film won't attract dust or dirt
- Non-flammable
- No silicone or chlorinated solvents
- Safe on most surfaces



Model No.	Mfg. No.	Size	Price /Each
AA870	C02616	11 oz.	32.50

DRY LUBE PTFE SPRAY

- Lubricates and provides superior long-lasting corrosion protection with no oily residue
- Reduces friction and wear on blades and bits, door and window tracks, slides, conveyor belts, rollers, hinges, power tools and equipment
- Won't attract dirt, dust or oil
- Container Type: Aerosol Can
- Film Type: Dry



Model No.	Mfg. No.	Size	Price /Each
AF175	2209	284 g	13.50

3-36® MULTI-PURPOSE LUBRICANT

- NSF Category Code: H2
- Multi-purpose lubricant that also serves as a penetrant and corrosion inhibitor
- Leaves a clear, thin and long-lasting film



Model No.	Mfg. No.	Size	Price /Each
YA180	73005	311 g	18.90

CHAIN & WIRE ROPE LUBRICANT

- NSF Category Code: H2
- Blend of synthetic lubricants that penetrate deep and leave a tough protective film
- Extends the working life of chains and wire rope
- Reduces wear caused by corrosion and friction



Model No.	Mfg. No.	Size	Price /Each
MLN961	73050	283 g	21.90

EXTREME DUTY OPEN GEAR LUBE

- Recommended for reducing friction and wear in harsh environments
- Resists to heat and pressure



Model No.	Mfg. No.	Size	Price /Each
AF267	73058	340 g	26.90

MR311 DRY FILM RELEASE AGENT

- Non-silicone mould release
- Exceptional anti-stick properties that will not transfer to finished parts allowing for multiple releases per application
- Compatible with most mouldable resins, elastomeric compounds, urethanes and styrenes
- Will not attack rubber, paints or metals
- Recommended for low and high-temperature moulds up to 575°F
- For polystyrenes, polypropylenes, nylon, rubber, foams, metals, filament windings, polyurethanes, epoxy potting and encapsulating and phenolic resins
- NSF Certified



Model No.	Mfg. No.	Size	Price /Each
AA174	SC0311000	12 oz.	35.20

SF 7900™ CERAMIC SHIELD FOR WELDING

- Ceramic dry film protective coating for MIG/MAG welding processes
- Protects contact tips and welding nozzles by preventing adhesion of welding spatter
- Once applied the coating dries by solvent evaporation within 5 to 10 seconds at room temperature (Thicker films will need longer drying time)
- Ceramic, silicone-free protective coating, easy to apply
- Protects contact tips, welding nozzles and jigs, eliminating cost for cleaning equipment
- Reduces running costs for consumables by up to 40%
- Prevents adhesion of welding spatter for many hours with just one application
- Colour: White



LOCTITE

Model No.	Mfg. No.	Size	Price /Each
AD492	1616692	9.5 oz.	57.90

SF7607™ RUBBERIZED UNDERCOATING

- Heavy-duty undercoating seals, protects, and insulates
- Rubberized for maximum durability



LOCTITE

Model No.	Mfg. No.	Size	Price /Each
AA635	234926	16 oz.	13.50

COLOR GUARD® TOUGH RUBBER COATING

- Inhibits rust and corrosion
- Seals, insulates, and identifies almost any material in minutes
- Creates a non-slip gripping surface
- Rubber coating won't crack or chip
- Acid and alkali resistant
- Lasts for years
- Use to 200°F
- For dip, spray, or brush
- For tools, metal, electrical connections, masonry, wood, conveyors, glass, rope, fabric
- Toluene-free



LOCTITE

Model No.	Mfg. No.	Size	Colour	Price /Each
AC013	338124	14.5 oz.	Black	38.90
AC014	338125	1 gal.	Black	259.00
AC016	338127	14.5 oz.	Blue	37.90
AC017	338128	1 gal.	Blue	265.00
AC011	338130	14.5 oz.	Red	37.50
AC012	338131	1 gal.	Red	249.00
AC015	338134	1 gal.	Yellow	285.00

PC 4400 PAINT PROTECT & RESTORE COATING

- Reduces repaint cycles and surface maintenance with industry leading scratch, UV, abrasion, salt and chemical resistance to extend paint life by up to 10 years
- When applied to faded or oxidized paint, PC 4400 makes the old paint look like-new again
- With both hydrophobic and oleophobic properties, PC 4400 repels water, dirt, oil and algae keeping the vehicle clean with quicker wash cycles
- Use LOCTITE 4401 as a matting additive and LOCTITE 4402 as an accelerator additive
- Key applications: Agricultural Equipment, Construction, Mining, Utility Vehicles, Salt/Plow Trucks, Specialty Buses, Rail, Military, Forestry, Freight/Delivery Trucks, Garbage Haulers, Specialty Fleet Vehicles
- Colour: Clear



LOCTITE

Model No.	Mfg. No.	Size	Price /Each
AH174	2573885	1.1 L	379.00
AH175	2573975	3.8 L	869.00

7332 NORDBAK® WEAR PREVENTION COATING

- Silicon carbide filled system
- Extremely high fine particle wet abrasion resistance
- Good dry and wet temperature resistance
- Easy to mix and apply; trowelable and non-sagging
- Coverage: 0.74 m² @ 6 mm thick for a 10 kg kit
- Functional cure in 6 hours
- Type: Two-Part
- Colour: Grey



LOCTITE

Model No.	Mfg. No.	Size	Price /Each
AH172	2751067	10 kg	1469.00

9593 NORDBAK® WEAR PREVENTION COATING

- Outstanding resistance to impact and wear
- Functional cure in 4 hours
- Rubber toughened polymer matrix with alumina bead and silicon carbide
- Easy to mix
- Coverage: 0.245 m² @ 6 mm thick for a 3 kg kit
- Type: Two-Part
- Colour: Clear



LOCTITE

Model No.	Mfg. No.	Size	Price /Each
AH173	2755354	10 kg	1539.00

TUMBLER PAINTABLE RUBBERIZED UNDERCOATING

- Fast drying paintable rubberized undercoating is exceptionally resistant to abrasions
- Remains flexible
- Compatible with standard automotive paints



kleen-flo

Model No.	Mfg. No.	Size	Price /Each
KR768	2785	550 g	12.50

CHEMICALS

RED & REDI MULTI-PURPOSE RED GREASE

- Delivers excellent lubrication
- Prevents rust, corrosion and oxidation
- Remains effective at extremely high temperatures
- Reduces friction and vibration
- Resists shock
- Red colour allows easy visual inspection
- Penetrates quickly
- Non-melting



Model No.	Mfg. No.	Size	Price /Each
AA873	C05816	11 oz.	26.50

WHITE LITHIUM GREASE W/PTFE

- Rapidly forms into a pure white grease
- Heat and water resistant
- Produces a long lasting, protective film against rust and corrosion
- White colour allows easy visual inspection
- Does not contain any chlorinated solvents
- Accepted for use in Canadian food processing facilities



Model No.	Mfg. No.	Size	Price /Each
AA914	C03816	10 oz.	27.50

LU100 WHITE LITHIUM GREASE

- Inhibits corrosion on unpainted metal surfaces
- High-solids, non-staining white grease
- Excellent for metal-to-metal applications
- Will not drip or run on vertical surfaces
- Effective from -20°F to 275°F
- For chains, gears, drives, hinges and other vertical or overhead surfaces
- Recommended for use on knock-out pins on mould equipment
- NSF registered category code H2



Model No.	Mfg. No.	Size	Price /Each
AA103	SC010000	11 oz.	17.60

VIPERLUBE™ HIGH PERFORMANCE SYNTHETIC GREASE

- Grease provides superior protection against equipment exposed to a wide range of operating temperatures and environments
- Use as a lubricant and protective anti-rust film on bearings, machine parts, equipment, or as a release agent on gaskets and seals
- Temperature resistance: 400°F (204°C) continuous
- NLGI Grade: 2/Severe Duty GC-LB
- NSF registered category code H1
- Accepted for use in Canadian food processing facilities



Model No.	Mfg. No.	Size	Price /Each
AB505	457456	3 oz.	13.90
AB508	457457	14 oz.	36.90
AB507	457458	400 g.	39.50
AB509	459782	30 lbs.	1019.00

DIELECTRIC GREASE

- Moisture proof barrier that lubricates and protects electrical equipment from salt, dirt, and corrosion
- High dielectric strength
- Good thermal, oxidation and chemical stability
- Temperature resistance: 400°F (204°C) continuous



Model No.	Mfg. No.	Size	Price /Each
AC365	270640	0.33 oz.	8.69

WHITE LITHIUM GREASE

- For metal-to-metal and metal-to-plastic applications
- Corrosion protection
- No ODC's
- Temperature resistance: 380°F (193°C) dropping point



Model No.	Mfg. No.	Size	Price /Each
AE854	1906122	10.75 oz. Aerosol	15.50

LU103 RUST BREAKER™ HEAVY DUTY RUST PENETRANT

- Quickly loosens rust while penetrating grease and dirt
- Transparent, non-staining oil
- Light film displaces moisture and acts as a corrosion preventative
- Jet stream sprays up to two feet for safe, accurate application
- Flashpoint: 205°F
- Will not harm painted surfaces
- For releasing rusted or frozen lugs and bolts, lubricating tight-fitting parts, general overhaul, repair work, food plant equipment



Model No.	Mfg. No.	Size	Price /Each
AA113	SC0103000	10 oz.	18.30

MULTI-PURPOSE CONCRETE REPAIR & ADHESIVE

- Excellent for bridging horizontal or vertical cracks, even under water
- Twice as strong as concrete
- Works on concrete, masonry, brick, steel and more
- For indoor or outdoor use
- Colour: Light Gray



Model No.	Mfg. No.	Size	Price /Each
KP497	257395	9 oz.	58.30
KP498	257397	Replacement Static Mixers - 3 Pack	21.90

TURBOKRETE CONCRETE PATCH COMPOUND KITS

- Easily repair deep holes and cracks
- 100%-solids epoxy patch kit is designed for floors exposed to heavy traffic and intermittent chemicals
- Protects against abrasion, impact and most chemicals—no sealer required
- Creates an extremely hard surface – 3-4 times stronger than concrete
- For interior/exterior use on damaged or severely spalled floors, curbs, ramps, etc.
- Odorless
- Easy-mix kit includes base, activator and aggregate
- Colour: Light Gray



Model No.	Mfg. No.	Size	Price /Each
KP495	253479	2 gal.	200.00
KP496	5494323	3.5 gal.	397.00

LPS 3® HEAVY-DUTY INHIBITORS

- Protects up to two years
- Stops rust and corrosion
- Provides non-sling lubrication
- Non-flammable propellant
- Self-healing, waxy film
- Provides anti-seize coating
- Safe to use on rubber, fabric, plastics and paints
- Meets or exceeds these specs: Boeing BMS-3 23F Type II, MIL-C-0083933A, para.3.2-3.16, MIL-C-16173D Grade 2 Class I, DMS 2150, Airbus TN A. 007.10138 Type I Grade 2
- Accepted for use in Canadian food processing facilities



Model No.	Mfg. No.	Size	Price /Each
AA808	C00316	11 oz.	36.90
AB559	C00322	20-oz. trigger	47.50
AB558	C03128	1 gal.	169.00
AB556	C00305	5 gal.	705.00
AB557	C00355	55 gal.	5575.00



TKX ALL-PURPOSE LUBRICANT

- Non-flammable CO₂ propellant
- Displaces moisture
- High flash point of 175°F (79°C)
- Protects against corrosion
- Loosens rusted or frozen parts
- Does not contain chlorinated solvents or silicones
- Safe on most surfaces
- Inverta spray valve lets you spray in all directions
- NSF registered category code H2
- Provides non-drying long-lasting, oily film



Model No.	Mfg. No.	Size	Price /Each
AA846	C02016	11 oz.	12.90
AB490	C02028	1 gal.	105.00
AB638	C02005	5 gal.	445.00
AB639	C02055	55 gal.	5029.00

BRIGHT COAT COLD GALVANIZE CORROSION INHIBITORS

- Shiny zinc coating
- Prevents rust and corrosion on all metals
- Restores hot dip galvanizing
- Dries to touch in 15 to 30 minutes
- Repairs rusted, galvanized and welded surfaces
- Electrochemically protects bare metal
- Heat resistant, flexible coating
- Will not yellow, chalk, crack or peel



Model No.	Mfg. No.	Size	Price /Each
AB485	C05916	13 oz.	26.50

LST PENETRANT

- Specially formulated with low surface tension for fast penetrating action
- Attacks rust and corrosion to free frozen parts
- Powerful foaming action provides complete surface coverage
- Displaces moisture
- Lubricates and protects metal surfaces
- Flash point of 175°F (79°C)
- Inverta spray valve lets you spray in all directions
- NSF registered category code H2



Model No.	Mfg. No.	Size	Price /Each
AA843	C01916	11 oz.	21.50

PENETRATING OIL

- Flashpoint: 60.6°C
- Slow evaporation rate
- A no-compromise penetrant that attacks corrosion to free corroded fasteners and mechanical components
- A super-fast, powerful, concentrated penetrating solvent that loosens and cleans
- Instantly penetrates tightly fitted crevices
- NSF Registered H2



Model No.	Mfg. No.	Size	Price /Each
YB991	73060	312 g	13.50

KB 88 THE ULTIMATE PENETRANT

- Quickly releases rusted and corroded nuts, bolts, hinges and other frozen components
- Extremely high solvency, low surface tension
- Enhanced penetration and lubrication
- Outperforms the competition in independent lab tests
- Penetrates faster and deeper than most other similar products in the market place
- Inverta spray valve
- NSF registered category code H2
- VOC compliant



Model No.	Mfg. No.	Size	Price /Each
AD970	C02316	13 oz.	26.90
AD297	C02322	20 oz. trigger	35.90

WD-40

- Loosens rusted parts
- Displaces moisture
- Non-conductor, dries out electrical and electronic equipment
- Stops squeaks
- Lubricates and protects against moisture and corrosion
- Operating temperature: -50°F to 300°F
- Minimum flash point 110°F open cup



Model No.	Mfg. No.	Size	Price /Each
NA610	1005	155 g aerosol	8.40
NA611	01111	11 oz. aerosol	12.60
NA609	01010	3.785 L	63.80

BOLT-OUT™

- Penetrates then lubricates
- Faster disassembly with less effort
- Inhibits further rust
- Displaces moisture
- No chlorinated solvents
- Non-flammable liquid formula
- Effective at wide temperature range



Model No.	Mfg. No.	Size	Price /Each
YC429	53-D 892	400 ml	18.50
AC310	53-D 893	500 ml trigger	27.90
AA479	53-D 897	20 L	429.00
AC311	53-D 898	200 L	3098.00

SCREWLOOSE™ SUPER PENETRANT

- Maximum Working Temperature: 141°F (61°C)
- Ideal for rusted and frozen metals
- Can also be used as a multi-purpose lubricant



Model No.	Mfg. No.	Size	Price /Each
AF244	75330	312 g	10.90



EXTEND® RUST TREATMENTS

- Goes on white and converts rust to a durable, black, metal-protective coating in 10 minutes
- Wirebrush parts and apply with brush or spray
- Surface rust must be present
- Use as a primer or finish coat
- Resists temperatures to 250°F intermittent, 200°F continuous
- Approved by the American Bureau of Shipping



LOCTITE

Model No.	Mfg. No.	Size	Price /Each
AA633	234981	1 qt.	72.50
AA634	160802	1 gal.	249.00
AC110	234984	5 gal.	1265.00

ZINC MATE™

- Flashpoint: -19°C
- Fast evaporation rate
- Working Temperature: 54.4°C (Continuous) and 65.6°C (Intermittent)
- High performance coating of >93% pure zinc that electrochemically bonds with ferrous metals to form a galvanic cell
- Actively fights rust and corrosion
- Use as a touch-up for damaged galvanized coatings



CRC

Model No.	Mfg. No.	Size	Price /Each
YA185	73054	369 g	20.90

BIO-RUST NEUTRAL PH RUST REMOVERS

- Removes rust and other metallic particles
- VOC free, solvent free, non-flammable, pH neutral solution biodegradable
- Not controlled under WHMIS
- Non-corrosive rust remover
- High workload - can remove 1.5 kg (3.3 lbs.) of iron oxide per 20 L
- For use with iron and mild steel
- Deeply rusted parts may require longer soaking time
- After application of Bio-Rust, rinse parts in water to remove loosened contaminants
- After removing rust, dip pack into fresh bath or Bio-Rust to provide short term corrosion protection
- It is recommended to degrease part before using Bio-Rust
- Bio-Rust is designed for immersion applications only
- Immerse parts in Bio-Rust at room temperature and let react for at least 30 minutes



Model No.	Mfg. No.	Size	Price /Each	
		Litres	Gallons	
AD441	53-G247	20	5.2	339.00
AD442	53-G248	208	55	2359.00

RUST RELEASE PENETRANT

- Penetrates deep into crevices, threads and seams to break the bonds that hold stuck parts together
- Ideal for use on nuts, bolts, threads and locks
- Leaves behind a protective layer and helps prevent rust and corrosion from re-forming
- Quickly goes to work on rusted nuts, bolts, threads, locks and chains



SPECIALIST

Model No.	Mfg. No.	Format	Price /Each
AH420	01278	311 g	14.30

SP-400™ CORROSION INHIBITOR

- Long-term indoor/outdoor corrosion inhibitor that provides protection of all equipment subject to heat, humidity, chemicals or severely corrosive atmospheres
- Ideal on machined surfaces and assemblies subjected to long periods of storage
- NSF Registered H2



CRC

Model No.	Mfg. No.	Size	Price /Each
AF108	73282	284 g	20.90

COLD GALVANISED CORROSION INHIBITORS

- 95% zinc-rich galvanized coating
- Commonly used as a flash rust preventative on welded areas
- Works like a hot-dip on ferrous metals indoors and out
- Three-year protection
- Withstands water temperature up to 212°F (100°C) and continuous dry heat up to 750°F (400°C)
- Flexible coating will not yellow, chalk, crack or peel
- Electrochemically protect bare metal
- Meets or exceeds these specs: MIL-P-46105 Weld Through Primer, Passes Preece Test for Hot-Dip Galvanizing



LPS

Model No.	Mfg. No.	Size	Price /Each
AA807	C00516	14-oz.	32.50
AB552	C05128	1 gal.	679.00

FIXMASTER® STEEL PUTTY

- Steel filled, non-sagging, two-part epoxy that cures to a metal-like finish for rebuilding or repairing metal parts
- 0.3 sq.ft. coverage, at 1/4" thickness
- 225°F maximum operating temperature
- 4900 PSI tensile strength
- 30 minutes working time
- Functional cure in 6 hours
- Accepted for use in Canadian food processing facilities
- Colour: Grey



LOCTITE

Model No.	Mfg. No.	Size	Price /Each
AC341	219292	1 lb. kit	109.00

FIXMASTER® ALUMINUM PUTTY

- Rebuilds and repairs aluminum equipment, forming a non-rusting finish
- 0.5 sq.ft. coverage, at 1/4" thickness
- 225°F maximum operating temperature
- 4000 PSI tensile strength
- 20 minutes working time
- Functional cure in 6 hours
- Accepted for use in Canadian food processing facilities
- Colour: Aluminum



LOCTITE

Model No.	Mfg. No.	Size	Price /Each
AC334	235615	1 lb. kit	225.00

FIXMASTER® STAINLESS STEEL PUTTY

- Forms a non-rusting, very hard, durable finish on damaged stainless steel surfaces
- 0.25 sq.ft. coverage, at 1/4" thickness
- 225°F maximum operating temperature
- 4600 PSI tensile strength
- 20 minutes working time
- Functional cure in 6 hours
- Accepted for use in Canadian food processing facilities
- Colour: Grey



LOCTITE

Model No.	Mfg. No.	Size	Price /Each
AC332	235613	1 lb. kit	209.00

ZINC-100™ BRIGHT GALVANIZING SPRAY

- Bright galvanizing spray provides long-lasting corrosion protection
- Specially formulated for the touch-up and repair of hot galvanized parts
- Zinc flakes permanently bond to metallic surfaces
- Bright metallic finish matches hot dipped look
- Fast drying
- Zinc-rich formula meets ASTM A780 standard
- For use on ferrous metals and steel
- Suitable for touch-up, repair, manufacturing or installation of food processing equipment, water storage tanks, fencing, outside structures, playground and sports equipment, scaffolding, ducting and air conditioning systems, marine equipment, architectural and ornamental structures, and steel components



Model No.	Mfg. No.	Size	Price /Each
AA196	53H102	400 ml	28.90

ZINC-200™ COLD GALVANIZING SPRAY

- High-performance, fast-drying corrosion protection spray specially formulated for ferrous metals
- Actively fights rust and corrosion
- Dual-action protection with its resin coat and galvanic action
- 95% pure zinc
- Dull finish and dries to touch in 3-5 minutes
- Meets ASTM A780 & MIL specifications
- Applications include manufacturing, repair, and installation of fencing, outside structures, playground and sports equipment, scaffolding, ducting and air conditioning systems, marine equipment, and architectural and ornamental structures



Model No.	Mfg. No.	Size	Price /Each
AB646	53H152	400 ml	27.90

THERMAPLEX® MULTI-PURPOSE BEARING GREASE

- Excellent load carrying properties
- Prolongs bearing life
- Ideal for lubricating all types of bearings
- Blue coloured paste
- Petroleum odour
- Temperature range: -22°F (-30°C) to 350°F (177°C)
- Dropping point: 429°F (220°C)
- NLGI Grade: No. 2
- Lithium complex



Model No.	Mfg. No.	Size	Price /Each
AA847	C70614	400 g	26.50

THERMAPLEX® AQUA BEARING GREASE

- Resists water washout
- Excellent corrosion resistance
- Significant load carrying capability
- Greater degree of bearing protection
- Amber coloured paste
- Petroleum odour
- Temperature range: -4°F (-20°C) to 302°F (150°C)
- Dropping point: 500°F (260°C)
- NLGI Grade: No. 2
- Aluminum complex



Model No.	Mfg. No.	Size	Price /Each
AA851	C70514	400 g	27.90

THERMAPLEX® HI-LOAD BEARING GREASE

- Withstands shock loading
- Reduces wear from vibration
- Excellent anti-wear properties
- Wide operating temperature range
- Blue/black colour paste
- Lithium complex
- Petroleum odour
- Moly-fortified for extreme applications to 350°F (177°C)
- Dropping point: 429°F (220°C)
- NLGI Grade: No. 2



Model No.	Mfg. No.	Size	Price /Each
AA850	C70414	400 g	31.90

THERMAPLEX® FOODLUBE BEARING GREASE

- Metal & X-ray detectable plastic component
- Ensures safety in areas where incidental food contact may occur
- Does not contain, solvents or silicone
- Non-staining and non-emulsifying
- White coloured paste
- Mild odour
- Aluminum complex
- Temperature range: -4°F (-20°C) to 302°F (150°C)
- Dropping point: 500°F (260°C)
- NLGI Grade: No. 2
- Made of FDA compliant materials
- NSF registered category code H1
- Accepted for use in Canadian food processing facilities



Model No.	Mfg. No.	Size	Price /Each
AA852	C70114	400 g	49.50

THERMAPLEX® HI-TEMP BEARING GREASE

- Resists carbonization at high temperatures
- Extends relubrication intervals
- Reduces risk of bearing failure at high temperature
- Ensures optimal production rates
- Smooth, brown paste
- Petroleum odour
- Lithium complex
- Temperature range: -15°F (-26°C) to 392°F (200°C)
- Dropping point: 536°F (280°C)
- NLGI Grade: No. 2



Model No.	Mfg. No.	Size	Price /Each
AA848	C70214	400 g	37.90

THERMAPLEX® CS MOLY BEARING GREASE

- Excellent oxidation stability, adhesive and cohesive properties and corrosion resistance
- Exceptional water resistance
- Premium performance
- Calcium sulfonate grease
- Contains molybdenum disulfide
- Reduces wear from vibration
- High load carrying capacity
- Prolongs bearing life
- Wide operating temperature range: 0°F to 425°F (-18°C to 218°C)
- Extends re-lubrication intervals for bearings
- NLGI No. 2
- NSF registered category code H2



Model No.	Mfg. No.	Size	Price /Each
AD179	C70814	400 g	35.90

PISTOL GREASE GUNS

HEAVY-DUTY

- Designed for use in general confined spaces or where access to grease nipples is restricted
- Heavy-duty die cast grease gun head
- Develops 5000 PSI
- Capacity: 14 oz (400 g) grease cartridge or suction fill
- AC475 comes complete with 4" steel extension and 4-jaw coupler with ball check
- AC476 comes complete with 18" flexible hose and 4-jaw coupler with ball check

Model No. AC475
Price/Each \$36.55
Model No. AC476
Price/Each \$44.85



AURORA
TOOLS

CHEMICALS



BIG FOOT™ PRIMER/SEALER

- Specially formulated to increase adhesion and coverage of all Big Foot™ Anti-Slip Coatings except Acrylic Pedestrian Grade and Glow Coat
- For use on concrete, wood, tile, and other porous substrates
- Water-based
- 320 sq. ft. coverage
- Maximum temperature 140°F
- 120 minutes working time
- 3-6 hours, functional cure



LOCTITE

Model No.	Mfg. No.	Size	Colour	Price /Each
AA609	1617851	1 gal.	Clear	615.00

BIG FOOT™ VEHICULAR GRADE

- Withstands even the heaviest rolling equipment traffic
- Resists liquids as harsh as jet fuels and hydraulic fluids
- Superior adhesion forms a solid bond to metal, concrete, and wood
- 40 sq. ft. coverage per gal.
- Max. temperature 140°F
- 120 minutes working time
- 12/72 hours, functional cure



LOCTITE

Model No.	Mfg. No.	Size	Colour	Price /Each
AA605	1602678	1 gal.	Black	385.00

BIG FOOT™ ANTI-SLIP FLOOR COATINGS

HEAVY-DUTY PEDESTRIAN GRADE

- Fire retardant when cured
- For areas with heavy pedestrian or light rolling traffic
- Ideal for ramps, walkways, locker rooms, stairs, and assembly areas
- 50 sq. ft. coverage per gal.
- Max. temperature 140°F
- 12/72 hours, functional cure



LOCTITE

Model No.	Mfg. No.	Size	Colour	Price /Each
AA603	1602679	1 gal.	Black	269.00
AA604	1602121	1 gal.	Grey	309.00

FIXMASTER® MAGNA-CRETE®

- Two-component, rapid setting concrete repair and grouting system
- Chemically resistant to most common liquids and chemicals
- For concrete, wood, glass, steel, and other construction materials
- 4.8 sq. ft. coverage
- Pourable
- Max temperature 2000°F
- 15 minutes working time
- 1-2 hours, functional cure
- Accepted for use in Canadian food processing facilities



LOCTITE

Model No.	Mfg. No.	Size	Colour	Price /Each
AA748	235572	1 gal.	Grey	179.00
AD917	235573	5 gal.	Grey	345.00

FIXMASTER® DEEP POUR GROUT

- Aggregate-filled, epoxy system for pours up to 6" deep
- For self-leveling applications under rails and sole plates
- Bonds to steel, concrete, and itself
- Withstands high torque loading
- 660 cu.in. of coverage
- Pourable
- Maximum temperature 225°F
- 30 minutes working time
- 24 hours, functional cure
- Accepted for use in Canadian food processing facilities



LOCTITE

Model No.	Mfg. No.	Size	Colour	Price /Each
AA745	235637	5 gal.	Black	609.00

FIXMASTER® MAGNA-GROUT™

- A two-component, rapid-setting concrete repair and grouting system with same properties as the Magna-Crete™ but containing smaller aggregate so that the mixed material can be poured thinner for resurfacing applications and feather edging.



LOCTITE

Model No.	Mfg. No.	Size	Price /Each
AE626	1476710	5 gal.	359.00

ACRYLIC URETHANE FLOOR PAINT

- Convenient, high-gloss, water-based coating is ideal for use in mild industrial or commercial setting
- Protects concrete floors from dusting, water damage, staining and mildew
- Paint and go—no measuring or mixing; minimal surface prep
- Dries fast—accepts next-day foot traffic
- Finish: High Gloss



RUST-OLEUM

Model No.	Mfg. No.	Size	Colour	Price /Each
KP490	251286	1 gal.	Safety Yellow	99.90
KP491	251291	1 gal.	Silver Grey	99.90
KP492	251293	5 gal.	Silver Grey	503.00

FIXMASTER® FLOOR FILL

- Trowelable
- For repairing and resurfacing cracks in concrete floors
- Bonds to old and new concrete and provides greater strength and chemical resistance
- 133 cu.in. of coverage
- Semi-pourable
- Max temperature 225°F
- 40 minutes working time
- 24 hours, functional cure



LOCTITE

Model No.	Mfg. No.	Size	Colour	Price /Each
AC362	235632	10 lbs.	Grey	255.00
AA747	235633	40 lbs.	Grey	699.00

WATER-BASED SINGLE COMPONENT ACRYLIC FLOOR COATING

- General purpose
- 100% acrylic
- Low odour
- For exterior/interior use
- Dries rapidly to a tough, alkali resistant finish which will withstand hard wear, abrasion, grease, oils, and cleaning equipment
- For use over prepared concrete and wood floors, steps, stairwells, aiseways, or previously painted floor surfaces in sound condition
- Not recommended for areas subject to hot tire pickup



KRYLON INDUSTRIAL

Model No.	Size	Colour	Price /Each
AC603	1 gal.	Grey	125.00

FIXMASTER® STEEL LIQUID

- Steel filled
- Pourable and self-leveling
- Recommended for casting into hard to reach areas, anchoring and leveling, and forming moulds and fixtures
- 13 in.³ coverage, at 1/4" thickness
- 225°F maximum operating temperature
- 6000 PSI tensile strength
- 25 minutes working time
- Functional cure in 6 hours
- Accepted for use in Canadian food processing facilities
- Colour: Grey



LOCTITE

Model No.	Mfg. No.	Size	Price /Each
AC340	235617	1 lb. kit	189.00

FIXMASTER® ALUMINUM LIQUID

- Two-part, pourable epoxy system heavily reinforced with aluminum powder
- For casting and repairing of aluminum parts, and for making molds and fixtures
- 17 in.³ coverage, at 1/4" thickness
- 200°F maximum operating temperature
- 6000 PSI tensile strength
- 20 minutes working time
- Functional cure in 6 hours
- Accepted for use in Canadian food processing facilities
- Colour: Aluminum



LOCTITE

Model No.	Mfg. No.	Size	Price /Each
AC333	235614	1 lb. kit	319.00

FIXMASTER® FAST CURE POXY PAK™ EPOXY

- Bonds virtually any material to repair, fill, and seal holes, cracks, and worn surfaces
- 300°F temperature resistance
- 2300 PSI adhesive tensile shear
- 1 minute working time
- Fixtures in 4-6 minutes
- Full cure in 1 hour
- Colour: Clear



LOCTITE

Model No.	Mfg. No.	Size	Price /Each
AA739	1324007	1 oz.	15.50

FIXMASTER® FAST CURE EPOXY MIXER CUPS

- Excellent chemical resistance
- Fills porosities and can be used to build up worn parts
- For bonding glass, hard plastics, rubber, and metal
- 180°F temperature resistance
- 2000 PSI adhesive tensile shear
- 5 minutes working time
- Fixtures in 10 minutes
- Full cure in 12 hours
- Colour: Grey



LOCTITE

Model No.	Mfg. No.	Size	Price /Each
AC124	209717	10 x 4 g	91.50
AC125	209718	10 x 1 oz.	225.00

LOCTITE® 2000 PUTTIES

- Tensile Strength on Grit Blasted Steel: 675 PSI
- A self-leveling aluminum liquid that can be poured into molds and cavities
- Recommended for casting aluminum replacement parts and for making molds
- Is paintable and sandable



LOCTITE

Model No.	Mfg. No.	Size	Price /Each
AB739	235579	8 oz.	175.00

FIXMASTER® FAST SET STEEL PUTTY

- Faster setting version of the Loctite® Fixmaster® steel putty
- Sets in 3 minutes
- Accepted for use in Canadian food processing facilities



LOCTITE

Model No.	Mfg. No.	Size	Price /Each
AD012	219293	1 lb.	129.00

LOCTITE® FIXMASTER™ METAL MAGIC STEEL™

- Kneadable, two-part paste
- Working time: 3 minutes
- Sets in 10 minutes
- Adheres to damp surfaces
- Can be drilled, filed and painted
- Ideal for emergency sealing of leaking tanks and pipes
- Smooths welds, repairs small cracks in castings and fills oversized bolt holes
- NSF/ANSI 61 certified



LOCTITE

Model No.	Mfg. No.	Size	Price /Each
AD915	209681	4 oz.	30.90

FIXMASTER™ MAGNA-CRETE™ CONCRETE REPAIR

- Rapid setting concrete repair and grouting system
- Bonds to concrete, wood, glass, steel and construction materials
- CFIA approved
- Two-component system requires mixing of two parts.



LOCTITE

Model No.	Mfg. No.	Size	Price /Each
AF282	1012500	1 lb.	41.90

FIXMASTER® UNDERWATER REPAIR EPOXY™

- Two-component, room temperature curing epoxy adhesive used for high strength, permanent bonding of metals, ceramics, concrete, wood and most plastics
- Can withstand temperatures of up to 150°C (300°F)
- Works on both wet and dry surfaces and sets up and cures underwater
- Putty like material is ideal for plumbing, irrigation and marine applications because it is unaffected by chlorinated or salt water
- Typical applications include plugging and filling gaps, leaks and holes in pipes, fitting tanks, valves and pumps
- Accepted for use in Canadian food processing facilities



LOCTITE

Model No.	Mfg. No.	Size	Price /Each
AE628	235487	4 oz.	31.90

CHEMICALS

FLEXTEC™ ADHESIVE & SEALANT

- Used for bonding and sealing dissimilar substrates
- High viscosity, sag resistant one component adhesive/sealant based on silane
- Modified polymer, which cures to an elastic product
- Free of solvents, isocyanates and silicones

LOCTITE

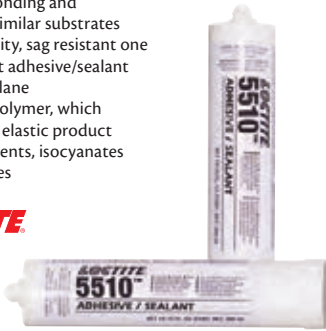

Model No.	Mfg. No.	Size	Colour	Price /Each
AD124	1562044	300 ml	Grey	25.50
AD125	1562042	300 ml	White	24.50
AD123	1560557	300 ml	Black	26.50
AF071	1562040	300 ml	Clear	27.90

SUPERFLEX™ BLUE RTV SILICONE ADHESIVE SEALANT

- Cures to a tough, flexible rubber
- "Formed in Place" gaskets resist shrinking, cracking and migrating
- Fills gaps to 0.25"
- Coats pre-cut gaskets
- Low volatility
- Tack free in 30 min 24 hrs., full strength
- Temperature range -65°F to 500°F (-54°C to 260°C) intermittent
- Colour: Blue



LOCTITE

Model No.	Mfg. No.	Size	Price /Each
AC198	270642	80 ml tube	14.50
AC199	270639	300 ml cartridge	26.50

SUPERFLEX™ SILICONE ADHESIVE SEALANT

- General purpose, one part silicone adhesive, cures at room temperature to form a tough rubber seal
- Will not slump in overhead or vertical applications
- Withstands extreme temperature cycling, U.V. light and ozone
- Cannot be painted
- Tack free in 30 min. 24 hrs., full strength
- Temperature range -65°F to 450°F (-54°C to 232°C) intermittent
- Accepted for use in Canadian food processing facilities



LOCTITE

Model No.	Mfg. No.	Size	Colour	Price /Each
AC157	193996	80 ml tube	Black	13.50
AC158	193997	300 ml cartr.	Black	27.90
AC196	160809	80 ml tube	Clear	13.50
AC197	193999	300 ml cartr.	Clear	26.50
AC121	135506	80 ml tube	White	15.50
AC113	193998	300 ml cartr.	White	29.90

3006™ ALL PURPOSE ADHESIVE CAULK

- Siliconized acrylic latex caulk perfect for most general purpose jobs
- Cured caulk is mildew & rust resistant
- Excellent colour retention
- Excellent flexibility and elasticity
- Smooth, professional application
- Exceeds performance requirements of ASTM C-834
- Net Volume: 295 ml
- Container Type: Cartridge



WHITE LIGHTNING

Model No.	Colour	Price /Each
AG833	White	7.84

SUPERFLEX™ RED HIGH TEMP RTV SILICONE

- Resists aging, weather and thermal cycling without shrinking, cracking or hardening
- Fills gaps to .25"
- Tack free in 30 min. 24 hrs., full strength
- Resist temperatures to 600°F (315°C) intermittent
- Colour: Red
- Accepted for use in Canadian food processing facilities



LOCTITE

Model No.	Mfg. No.	Size	Price /Each
AC166	135507	80 ml tube	16.50
AC167	198817	300 ml cartridge	29.90

598™ BLACK RTV SILICONE GASKET MAKER

- Adheres well to oily surfaces
- Low odour and volatility
- Fills gaps to 0.25"
- Forms tough, flexible gaskets directly on the flange
- Resistant to most chemicals and solvents
- Non-corrosive
- Tack free in 30 min. 24 hrs., full strength
- Temperature range: -75°F to 625°F (-59°C to 329°C) intermittent
- Colour: Black
- Accepted for use in Canadian food processing facilities



LOCTITE

Model No.	Mfg. No.	Size	Price /Each
AA488	234609	70 ml tube	24.50
AC195	135508	300 ml cartridge	51.50

FORM-A-THREAD®

STRIPPED THREAD REPAIR KIT

- Permanently repairs stripped threads and fasteners in 5 minutes
- Allows up to 128 lbs. of torque
- Operating temperature between -53° C - 148° C / -65° F - 300° F
- Accepted for use in Canadian food processing facilities



LOCTITE

Model No.	Mfg. No.	Size	Price /Each
AA458	236382	4.8 ml	54.50

PIPE REPAIR KITS

- Urethane impregnated fibreglass tape, activated by water, for reliable, temporary repairs of metal, plastic, and composite pipes
- Cures in 30 minutes
- Includes: Loctite® Fixmaster™ Metal Magic Steel™ epoxy stick, urethane impregnated fibreglass tape, and gloves
- Accepted for use in Canadian food processing facilities



LOCTITE

Model No.	Mfg. No.	Size	Price /Each
AA641	209818	2" x 6' tape	93.50

587™ BLUE RTV SILICONE GASKET MAKER

- Adheres well to oily surfaces
- Low odour and volatility
- Fills gaps to 0.25"
- Forms tough, flexible gaskets directly on the flange
- Resistant to most chemicals and solvents
- Non-corrosive
- Tack free in 30 min. 24 hrs., full strength
- Withstands temperatures to 500°F (260°C) intermittent
- Colour: Blue
- Accepted for use in Canadian food processing facilities



LOCTITE

Model No.	Mfg. No.	Size	Price /Each
AA489	135504	70 ml tube	23.90
AC201	234590	300 ml cartridge	51.50

MARINE GRADE ANTI-SEIZE

- Protects assemblies exposed directly or indirectly to fresh and salt water
- Works especially well in high humidity conditions
- Excellent lubricity, superior water wash-out water spray resistance
- Prevents galvanic corrosion



LOCTITE

Model No.	Mfg. No.	Size	Price /Each
AC338	299175	8 oz.	38.50
TDP003	275026	16 oz.	62.50

FOOD GRADE ANTI-SEIZE

- Prevents seizure, galling and friction in stainless steel and other metal parts up to 750°F (399°C)



LOCTITE

Model No.	Mfg. No.	Size	Price /Each
AC339	#N/A	8 oz.	39.90

HEAVY-DUTY ANTI-SEIZE

- Metal-free
- Excellent lubricity
- Outstanding lubrication to all metals including stainless steel, aluminum and soft metals up to 2400°F (1315°C)



LOCTITE

Model No.	Mfg. No.	Size	Price /Each
AC208	234347	9 oz.	63.50
AC328	209758	1.2 lb.	95.50

SILVER GRADE ANTI-SEIZE

- Heavy-duty, temperature resistant, petroleum-based lubricant
- Fortified with graphite and metallic flake
- Inert, will not evaporate or harden in extreme cold or heat
- For use in assemblies up to 1600°F (871°C)



LOCTITE

Model No.	Mfg. No.	Size	Price /Each
AC347	199012	8 oz.	31.50
YA275	135541	12 oz. aerosol	31.50
YA276	235005	1 lb.	42.50

COPPER ANTI-SEIZE

- Service rating: -65°F (-54°C) to 1800°F (982°C)
- Lead free, low friction lubricant in a water-resistant grease fortified with anti-oxidants
- Protects against seizure, heat-freeze, galling, rust and corrosion
- Permits reuse of fittings, saves stud, bolt and nut replacements
- Not affected by contraction, expansion or vibration
- Will not run, drip or settle out
- Copper colour

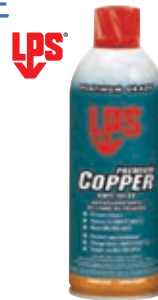

Model No.	Mfg. No.	Size	Price /Each
AA890	C02916	12 oz.	46.50
AA925	C02908	1/2 lb.	37.50
AA874	C02910	1 lb.	58.90

C5-A® COPPER BASED ANTI-SEIZE

- Suspends copper and graphite in a high quality grease
- Protects metal parts from rust, corrosion, galling, and seizing at temperatures to 1800°F (982°C)



LOCTITE

Model No.	Mfg. No.	Size	Price /Each
AC345	234263	8 oz.	29.90
AA533	1786073	12 oz. aerosol	41.50
AB467	160796	1 lb.	46.90

NICKEL ANTI-SEIZE

- Copper-free
- Recommended for stainless steel and other metal fittings
- For preventing corrosion, seizing and galling in harsh, chemical environments
- For temperatures to 2400°F (1315°C)



LOCTITE

Model No.	Mfg. No.	Size	Price /Each
AC337	235028	8 oz.	45.90
AA117	135543	1 lb.	64.50

ANTI-SEIZE QUICKSTICKS™

- Provides exceptional lubrication, as well as protection against rust, corrosion, seizing and galling
- Reduces friction and wear of critical parts
- Ideal for use in extreme cold and extreme heat applications between -20°F (-29°C) to 1600°F (870°C)
- Stick form offers less mess and portability
- Typical applications include copper, brass, cast iron, all alloys including stainless steel, all plastics and all non-metallic gasket materials
- Perfect for bolts, bushings, pipes, fittings, flanges, gaskets, headers, manifolds, studs and more
- Can withstand the stress of high heat ovens, crane assemblies, turbine studs, coal crushers, casting and molding equipment and heat exchangers

LOCTITE



Model No.	Mfg. No.	Format	Grade	Price /Each
AB653	466863	20 g	Copper	13.90
AB654	466864	20 g	Silver	12.50



ALL-PURPOSE ANTI-SEIZE

- Service rating: -65°F (-54°C) to 1800°F (982°C)
- Moly-fortified
- Lead free
- Protects against seizure, heat-freeze, galling, rust and corrosion
- Lowers friction and reduces wrench torque
- Not affected by contraction, expansion or vibration
- Will not harden, evaporate or settle out and requires no thinning
- Steel blue colour



Model No.	Mfg. No.	Size	Price /Each
AA924	C04108	1/2 lb.	46.50
AB475	C04110	1 lb.	68.90

NICKEL ANTI-SEIZE

- Service rating: -65°F (-54°C) to 2600°F (1427°C)
- Contains no lead, copper, graphite, chlorides, phosphorous, silicone or halogens
- Can be used with ammonia, acetylene and vinyl monomers, which are unstable in the presence of copper
- Protects against seizure, rust and corrosion
- Safe on stainless steel when temperatures exceed 550°F (288°C)
- Prevents water wash-off
- Will not run, drip or settle out
- Silver colour



Model No.	Mfg. No.	Size	Price /Each
AA926	C03908	1/2 lb.	46.50
AB637	C03910	1 lb.	87.90

565™ PST® CONTROLLED STRENGTH THREAD SEALANT

- General purpose instant sealant for tapered and straight/tapered fittings
- Controlled strength for ease of disassembly
- Withstands temperatures to 300°F
- Colour: White
- Accepted for use in Canadian food processing facilities



LOCTITE

Model No.	Mfg. No.	Size	Price /Each
AA540	88551	50 ml	28.90
AA541	88552	250 ml	105.00

567 HIGH TEMPERATURE THREAD SEALANT

- General purpose instant thread sealant for taper/taper threads and fittings
- High temperature thread sealant with PTFE
- Designed for the locking and sealing of metal pipes and fittings as well as other threaded assemblies
- Provides an instant, low-pressure seal for metal pipes and fittings
- Excellent chemical and thermal resistance
- Colour: White
- Temperature resistance up to: 480°F



LOCTITE

Model No.	Mfg. No.	Size	Price /Each
AF206	2087068	6 ml	11.50
AF207	2087067	50 ml	31.90
AF208	2087069	250 ml	119.00

592™ PST® SLOW CURE THREAD SEALANT

- Locks and seals threaded fittings
- Parts may be repositioned up to 24 hours after application
- Withstands temperatures to 400°F
- Colour: White
- Accepted for use in Canadian food processing facilities



LOCTITE

Model No.	Mfg. No.	Size	Price /Each
AC100	209761	50 ml	30.50
AB349	88568	250 ml	105.00

518 GASKET ELIMINATOR®

- Medium-strength gasket sealant
- Cures when confined in the absence of air between close-fitting metal surfaces
- Anaerobic gasketing material designed for use on rigid iron, aluminum, and steel flanged mating surfaces
- Colour: Red
- For gaps up to: 0.05"
- Temperature resistance up to: 300°F



LOCTITE

Model No.	Mfg. No.	Size	Price /Each
AF213	2096062	6 ml	11.50
AF214	2096064	50 ml	33.50
AF215	2096061	250 ml	129.00

FLANGE SEALANT 515™

- Flexible gaskets for rigid machined flanges
- Flexes with flanges that move in service
- For flexible applications
- 0.010" unprimed gap fill, 0.020" primed gap fill
- -65°F to 300°F
- Cures 1 to 12 hours (unprimed), 15 mins. to 2 hrs. (primed)
- Colour: Purple
- Accepted for use in Canadian food processing facilities



LOCTITE

Model No.	Mfg. No.	Size	Price /Each
AC088	135479	50 ml	32.50
AC089	88541	300 ml	129.00

545™ THREAD SEALANT HYDRAULIC/ PNEUMATIC SEALANT

- Liquid sealant for locking and sealing high pressure, fluid power systems with tapered fittings
- No fillers and will not foul valves or fluid filtering systems
- For locking and sealing hydraulic and pneumatic fittings, servomechanisms, and fine-filtration systems
- Specially formulated to offer lubricity for easy assembly
- Withstands temperatures to 300°F
- Colour: Purple
- Accepted for use in Canadian food processing facilities



LOCTITE

Model No.	Mfg. No.	Size	Price /Each
AC357	303420	10 ml	22.90
AA542	135486	50 ml	64.50

PST® 561™ THREAD SEALANT STICK

- Immediate low pressure sealing to 100 PSI
- Protects threads from rust and corrosion
- Exceptional fluid compatibility and chemical resistance
- Will not contaminate or clog lines
- Eases disassembly
- Seals all types of metal tapered threads and fittings to NPT specs
- For chemical processing, waste water treatment, and automotive
- Temperature resistance 300°F (150°C)
- Colour: White
- No mess, portable stick
- Accepted for use in Canadian food processing facilities



LOCTITE

Model No.	Mfg. No.	Size	Price /Each
AB652	463973	19 g	27.50



RMP
PRODUITS D'ENTRETIEN - MAINTENANCE PRODUCTS

609™ GENERAL PURPOSE RETAINING COMPOUND

- Low viscosity retaining compound that bonds rigid metal assemblies
- Ideal for gap distances up to 0.005"
- Fixtures in 10 minutes, full in 24 hrs.
- Provides a shear strength of 3000 PSI after 24 hours
- Withstands temperatures to 300°F
- Locks keys and splines - eliminates backlash in worn assemblies
- Locks bushings and sleeves in housings and on shafts
- Augments press fits
- Colour: Green
- Accepted for use in Canadian food processing facilities



LOCTITE

Model No.	Mfg. No.	Size	Price /Each
AA538	135511	10 ml	22.50
AA539	135512	50 ml	65.50

620™ HIGH TEMPERATURE RETAINING COMPOUND

- High temperature, high viscosity retaining compound
- Ideal for gap distances up to 0.015"
- Fixtures in 30 minutes, full in 24 hrs.
- Provides a shear strength of 3800 PSI on steel
- Withstands temperatures to 450°F
- Seals against leakage
- For retaining pins and sealing threads in steam platens and retaining valve seats
- Colour: Green
- Accepted for use in Canadian food processing facilities



LOCTITE

Model No.	Mfg. No.	Size	Price /Each
AA457	234772	10 ml	24.50
AC102	135514	50 ml	67.90

641™ CONTROLLED STRENGTH RETAINING COMPOUND

- For cylindrical parts that require disassembly
- Ideal for gap distances up to 0.008"
- Fixtures in 20 minutes, full in 24 hrs.
- Provides a shear strength of 1700 PSI
- Withstands temperatures to 300°F
- Colour: Yellow
- Accepted for use in Canadian food processing facilities



LOCTITE

Model No.	Mfg. No.	Size	Price /Each
AC355	233546	10 ml	32.90
AA546	231121	50 ml	76.50

660™ QUICK METAL® PRESS FIT REPAIR RETAINING COMPOUND

- Creamy, non-running adhesive/sealant
- Repairs worn machine parts
- Restores correct fit to mating assemblies
- Ideal for gap distances up to 0.020"
- For worn shafts and housings, bearing spinouts, keyways, and splines
- Fixtures in 20 minutes, full in 24 hrs.
- Shear strength of 3300 PSI on steel
- Withstands temperatures to 300°F
- Colour: Silver
- Accepted for use in Canadian food processing facilities



LOCTITE

Model No.	Mfg. No.	Size	Price /Each
AC103	209765	6 ml	17.50
AC104	135527	50 ml	70.50

QUICKSTIX™ 668™ RETAINING COMPOUND

- Used for bonding non-threaded, cylindrical metal assemblies with gaps up to 0.005" (0.13 mm)
- Prevents fretting and corrosion of metal assemblies up to 400°F (204°C)
- Accepted for use in Canadian food processing facilities



LOCTITE

Model No.	Mfg. No.	Size	Price /Each
AB937	640470	19 g	65.90

680™ HIGH STRENGTH/HIGH VISCOSITY RETAINING COMPOUNDS

- Ideal curing adhesive for joining fitted cylindrical parts
- Fixtures in 10 minutes and provides a shear strength of 4000 PSI
- Capable of filling diametral gaps up to 0.015 inches
- Gives the best resistance to dynamic, axial and radial loads
- Full Cure Time: 24 hrs.
- Colour: Green



LOCTITE

Model No.	Mfg. No.	Size	Price /Each
AF074	1835205	10 ml	23.50
AF075	1835201	50 ml	67.50

648™ HIGH STRENGTH/ RAPID CURE RETAINING COMPOUNDS

- Ideal for clearance and interface fit parts
- Excellent performance for dynamic, axial and radial loads
- Works through contaminants such as oils and corrosion protection fluids
- Cures on metals without needing an applicator
- Application Time: 3 minutes
- Full Cure Time: 24 hrs.
- Shear Strength: 3900 PSI
- Ideal for gap distance up to: 0.006"



LOCTITE

Model No.	Mfg. No.	Size	Colour	Price /Each
AF076	1835922	10 ml	Green	27.50
AF077	1835920	50 ml	Green	79.90

TEFLON SEALING TAPE

- Commonly used in plumbing for sealing pipe threads
- Ensures a tight seal
- Works for both water and air
- Colour: White
- Tape Material: PTFE
- Thickness: 3 mils (0.0762mm)
- Density: 0.37 grams/cubic centimeter
- Working Temperatures Range: -190°C to 260°C (-310°F to 500°F)



AURORA
TOOLS

Model No.	Width"	Length"	Price /Each
PG148	1/2	520	0.80
PG149	3/4	520	1.95

INSULATING & SEALING WRAP

- Non-sticky, self fusing, multipurpose wrap
- Withstand extreme conditions: -65°F to 500°F
- Tensile strength up to 700 PSI and dielectric strength up to 400 VPM
- UV, saltwater, fuel and acid resistant



LOCTITE

Model No.	Mfg. No.	Size	Colour	Price /Each
AD155	1212164	1" x 10' Roll	Red	23.50
AF072	1540599	1" x 10' Roll	Black	23.90



290™ WICKING GRADE THREADLOCKER

MEDIUM-HIGH STRENGTH

- For pre-assembled bolts up to 1/2" (12 mm)
- Penetrates threads by capillary action
- Secures set screws and other assemblies after settings are completed
- Localized heating and hand tools are needed for disassembly
- For preassembled fasteners, instrumentation screws, electrical connectors and carburetors
- Withstands temperatures to 300°F
- Torque: 85/250 in. lb.
- Fixtures in 6 minutes, full in 24 hrs.
- Colour: Green



LOCTITE

Model No.	Mfg. No.	Size	Price /Each
AA454	233731	10 ml	20.50
AA455	135392	50 ml	65.50
AA024	135393	250 ml	235.00

262™ HIGH STRENGTH THREADLOCKER

- For fasteners up to 3/4" (20 mm) dia.
- High lubrication for easy assembly
- Excellent for preventing rust and corrosion in extreme chemical/ environmental conditions
- For all fasteners that must withstand heavy shock, vibration, or extreme environmental or chemical conditions
- Withstands temperatures to 300°F
- Colour: Red
- Steel fixture time is 15 min, brass 8 min and stainless steel 180 min



LOCTITE

Model No.	Mfg. No.	Size	Price /Each
AA452	231926	10 ml	21.50
AA453	135374	50 ml	66.50
AA741	135375	250 ml	245.00

272™ HIGH TEMP./HIGH STRENGTH THREADLOCKER

- Recommended for bolts up to 1 1/2" (36 mm) in diameter
- Provides a fast cure on most surfaces including "as received" fasteners
- Heat and hand tools are required for disassembly
- Withstands temperatures to 450°F
- Torque: 200/220 in. lb.
- Fixtures in 30 minutes, full in 24 hrs.
- Colour: Red



LOCTITE

Model No.	Mfg. No.	Size	Price /Each
AA552	88442	50 ml	65.50
AC324	195542	250 ml	235.00

263™ HIGH STRENGTH/ RAPID CURE THREADLOCKER

- Designed for the permanent locking and sealing of threaded fasteners
- Ideal for heavy-duty applications such as studs into motor housings, nuts onto studs in pump housings and other fasteners where high strength is required
- Provides robust curing performance
- Works on active metals such as brass, copper and passive substrates such as stainless steel and plated surfaces
- Offers high temperature performance and oil tolerance
- Torque: 290 in./lb.
- Withstands temperature from -65°F to 360°F
- Fixture in 4 min., full 24 hrs.
- Colour: Red
- Acceptable for use in Canadian food processing establishments



LOCTITE

Model No.	Mfg. No.	Size ml	Price /Each
AD289	1330583	10	21.90
AH183	2205310	36	46.90
AD290	1330585	50	66.90
AD291	1330335	250	229.00

242® MEDIUM STRENGTH THREADLOCKER

- Removable threadlocker for fasteners between 1/4" and 3/4" (6 to 20 mm) diameters
- Controlled lubricity for accurate clamp loads
- Parts can be separated using hand tools
- For machine tools, presses, pumps, compressors, mounting bolts and gearboxes
- Withstands temperatures to 300°F
- Torque: 115/53 in. lb.
- Fixtures in 10 minutes, full in 24 hrs
- Colour: Blue



LOCTITE

Model No.	Mfg. No.	Size	Price /Each
AA450	135354	10 ml	21.50
AA451	135355	50 ml	67.50
AA652	135356	250 ml	245.00

243™ OIL TOLERANT/ MEDIUM STRENGTH THREADLOCKER

- For fasteners between 1/4" and 3/4" (6 to 20 mm) diameters
- Medium strength threadlocker with improved oil tolerance
- Parts can be separated using hand tools
- For machine tools, presses, pumps, compressors, mounting bolts and gearboxes
- Withstands temperatures to 360°F
- Torque: 180/62 in. lb.
- Fixtures in 5 minutes, full in 24 hrs
- Colour: Blue



LOCTITE

Model No.	Mfg. No.	Size	Price /Each
AA188	1329837	10 ml	21.90
AA555	1329467	50 ml	66.90
AC322	1329505	250 ml	229.00

246™ HIGH TEMP./ MEDIUM STRENGTH THREADLOCKER

- Suitable for fasteners between 1/4" and 3/4" (6 to 20 mm) diameters
- Resists oil and mild surface contamination at continuous temperatures to 450°F
- Torque: 170/48 in. lb.
- Fixtures in 20 minutes, full in 24 hrs.
- Colour: Blue



LOCTITE

Model No.	Mfg. No.	Size	Price /Each
AC353	196508	10 ml	26.50
AC330	234172	50 ml	81.50
AC321	234174	250 ml	319.00

222MS™ LOW STRENGTH THREADLOCKER

- Ideal for fastener diameters of 1/4" (6 mm) and smaller
- Controlled lubricity for accurate clamp loads
- Parts can be separated using hand tools
- For set screws, adjustment screws, calibration screws, meters and gauges
- Withstands temperatures to 300°F
- Torque: 62/27 in. lb.
- Fixtures in 20 minutes, full in 24 hrs
- Colour: Purple



LOCTITE

Model No.	Mfg. No.	Size	Price /Each
AA014	135333	10 ml	21.50
AA015	135334	50 ml	65.50
AA513	135335	250 ml	235.00

THREADLOCKER STICKS



LOCTITE

Model No.	Mfg. No.	Size	Price /Each
248™ MEDIUM STRENGTH - BLUE			
AB649	462476	19 gr.	51.50
AB648	826034	9 gr.	25.90
268™ HIGH STRENGTH - RED			
AB651	826035	19 gr.	52.50
AB650	826036	9 gr.	26.90

CURVED HANDLE SCRATCH BRUSHES



BZ606

Model No.	Brush Length	O.A. Length"	Description	Wire Rows	Trim Length"	Price /Each
BZ970	6	13 11/16	Stainless Steel	3 x 19	1 1/8	9.29
BZ606	6	13 11/16	Steel	3 x 19	1 1/8	4.59
NP248*	6	13 11/16	Steel	3 x 19	1 1/8	7.39
BZ607**	6	13 11/16	Steel	4 x 19	1 1/8	7.09

*With scraper ** Heavy-duty

CURVED-HANDLE SCRATCH BRUSHES

- Durable hardwood handles that have a smooth finish for extra comfort



TC065



Model No.	Brush Width"	Brush Length"	O.A. Length"	Fill Material	Wire Rows	Trim Length"	Price /Each
TC065	15/16	6	14	Steel	3 x 19	1 1/8	6.39
TC068	15/16	6	14	Stainless Steel	3 x 19	1 1/8	12.90
TT167	15/16	6	14	Brass	3 x 19	1 1/8	13.50
TC066	1 1/8	6	14	Steel	4 x 19	1 1/8	7.59
TT170	1 1/8	6	14	Stainless Steel	4 x 19	1 1/8	13.90
TT169	1 1/8	6	14	Brass	4 x 19	1 1/8	15.90

SHOE HANDLE SCRATCH BRUSHES

- Durable hardwood handles that have a smooth finish for extra comfort
- Brush Width: 1 1/16"



TC067



Model No.	Brush Length"	O.A. Length"	Fill Material	Wire Rows	Trim Length"	Price /Each
TC067	5 1/4	10	Steel	5 x 13	1 1/8	6.19
TC074	5 1/4	10	Stainless Steel	5 x 13	1 1/8	14.50
TT168	5 1/4	10	Brass	5 x 13	1 1/8	17.50

SCRATCH BRUSHES WITH SCRAPER

- Durable hardwood handles that have a smooth finish for extra comfort
- Hang-up hole for easy storage



NUS40



Model No.	Brush Width"	Brush Length"	O.A. Length"	Fill Material	Wire Rows	Trim Length"	Price /Each
STRAIGHT HANDLE							
TT171	1 1/2	5 1/2	11 3/8	Steel	5 x 13	1 1/8	17.90
CURVED HANDLE							
NUS40	15/16	5 3/4	13	Steel	3 x 19	1	8.09
NUS42	2	4	20	Stainless Steel	3 x 10	1	39.50

FLAT WIRE BUTCHER BLOCK BRUSHES

- Flat wire butcher block that offers a more aggressive scrub than round wire counterparts
- Durable hardwood block



NUS48

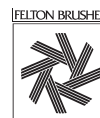

Model No.	Brush Width"	Brush Length"	O.A. Length"	Fill Material	Wire Rows	Trim Length"	Price /Each
NUS46*	4	8 1/2	9	Flat Steel Wire	8 x 12	1 1/8	47.90
NUS48	2 5/8	7	7 5/8	Flat Steel Wire	5 x 10	1	31.50

* Comes with a wood handle

ROUND WIRE BUTCHER BLOCK BRUSHES

- Round wire butcher block that offers a gentler scrub than flat wire counterparts
- Durable hardwood block
- Brush Width: 2 1/2"



Model No.	Brush Length"	O.A. Length"	Fill Material	Wire Rows	Trim Length"	Price /Each
NW102	7	7 1/4	Steel	6 x 19	1 1/8	11.50

INDUSTRIAL-DUTY SCRATCH BRUSHES

- Wood handle
- Choice of carbon or stainless steel bristles



NT607

NT609

NT615



Model No.	Brush Length	O.A. Length"	Wire Bristles	Rows	Trim Length"	Price /Each
LONG HANDLE BRUSHES						
NT607	5 3/4	13 3/4	Carbon Steel	3 x 19	1	3.60
NT608	5 3/4	13 3/4	Carbon Steel	4 x 19	1	4.25
NT611	5 3/4	13 3/4	Stainless Steel	3 x 19	1	5.50
NT612	6	10 1/4	Stainless Steel	4 x 19	1	5.95
SHOE HANDLE BRUSHES						
NT609	5 1/4	10 1/2	Carbon Steel	3 x 16	1	3.20
NT610	5 1/4	10 1/2	Carbon Steel	4 x 16	1	3.50
NT613	5	10 1/2	Stainless Steel	3 x 16	1	5.95
NT614	5	10 1/4	Stainless Steel	4 x 16	1	6.40
"TOOTHBRUSH" CLEANING BRUSH						
NT615	1 1/2	7 3/4	Stainless Steel	3 x 7	1/2	1.60

FUME EXTRACTORS



MOBILE FILTERS & MOBILE FILTERS ECO

- Mobile mechanical filter for welding fumes, grinding dust, etc
- Compact and flexible
- The extraction arm captures fume and dust at a distance of 30-50 cm (12-20") from the source and within an area of 0.5 m (20") diameter
- Black hood w/optimized airflow and ring handle and built in damper
- Flame proof PVC hose 160 mm (6.5") diameter
- This unit can also be fitted with an activated carbon filter which removes gases from polluted air

CONSTRUCTION:

- Unit made of powder painted steel sheet 16 ga.
- Fan 0,75 kW(1HP), 120 V, 1-phase, 2400 m³/hr (1400 CFM) free-blowing
- The unit filters 1250 m³/hr (700 CFM) through the hood
- Comes standard with 1-prefilter (spark-trap) and 1 washable (99% spun-bound polyester) cartridge filter (P-160)
- Active filter surface 14 m² (150+ ft²)
- Delivered complete with ON/OFF starter, cable, and plug
- Flameproof 6.5' PVC coated fibreglass hose
- **5-year limited warranty**

Model No.	Mfg. No.	Description	Price/Each
BA655	P-150/P-002	Mobile Filter w/2 m Extraction Arm	6316.00
BA656	P-150/P-003	Mobile Filter w/3 m Extraction Arm	6548.00
BA657	P-160	Replacement Filter Cartridge for BA655-BA656 (Cleanable with Compressed Air)	539.00
BA659	P-160-W	Replacement Filter Cartridge for BA655-BA656 (Washable with Soap and Hot Water, Suitable for Oily Smoke)	632.00
EA452	P-535/P-002	"Self Cleaning" Mobile Fume Extractor w/2 m Extraction Arm	7523.00
EA453	P-535/P-003	"Self Cleaning" Mobile Fume Extractor w/3 m Extraction Arm	8041.00
EA454	P-541	"Eco" Replacement Filter Cartridge for EA452-EA453 (Cleanable with Compressed Air)	564.00



MOBILE FUME EXTRACTORS W/SELF CLEANING FILTERS

For direct capture of dust, smoke and fumes. Suitable for the following applications:

- Dry Particulates
- Welding Smoke
- Fumes
- Carbon Dust
- Plastic Dust
- Ceramic Dust
- Woodworking
- Fibreglass • Synthetics
- Textiles
- Rubber Dust
- Grinding Dust
- Powders
- Dry Chemicals
- Composites
- Cotton Dust

Dirty air enters the cabinet from the hose and is directed vertically downward which results in a 180° turn at the bottom of the unit, causing separation of heavier particles into the removable dust pan. Second stage cartridge filter, traps the remaining particles with up to 99% efficiency.

SPECIFICATIONS:

Construction: 16-gauge steel cabinet finished with 2 part chemical and oil resistant paint. Includes Ultra-Seal® filter mounting system, removable access door to filters and direct drive motor/blower, 6.7" externally self-supporting E-Z Arm™ high flow pickup arm, 8" fixed front and 5" rear swivel casters, power cord, and on-off switch.

- Weight:** 255 lbs. Shipping weight 400 lbs.
- Airflow:** 1200 CFM with 1.5 HP motor
- Noise:** 70 dBA / 73 dBA 1.5 HP
- Electrical:** 1.5 HP 115/1/60
- Filter Seal:** Ultra-Seal® with positive sealing filter locking mechanism for all main filters, optional HEPA filter and adsorber modules (when used). Slide tracks shall be used for prefilters only.



Model No.	Mfg. No.	Description	Price /Each
BA710	PCH-1-1.5	Self Cleaning Mobile Filter w/2-m arm	19709.00
BA667	7FR02020	Replacement Filter Cartridge	419.00
BA712	PCH-1-PG-5	0-5" Dial Pressure Gauge	607.00

Note: Other extractors also available

FANS FOR FUME EXTRACTORS

- Powerful, silent, energy efficient fans provide even airflow with the lowest possible power consumption
- Extra bracket required for use with booms (use BA694 for 6.5" boom and EA456 for 8" boom)

Model No.	Mfg. No.	Voltage/ Phases/Amp	Free-Blowing HP	Free-Blowing CFM	Nominal (At-The-Hood) CFM	Price /Each
BA683	P-152-1	115/1/60	1.5	1400	1 @ 1000 CFM	1788.00
BA689	P-152-2	208-230-460/3/60	2.0	1700	2 @ 600 CFM or 1 @ 900 CFM	1648.00
BA693	P-152-3	575/3/60	2.0	1700	2 @ 600 CFM or 1 @ 900 CFM	1613.00
EA268	LD-150-1	208-230-460/3/60	7.5	3000	6 @ 600 CFM or 5 @ 900 CFM	7137.00

*Complete with Plug & Play



FUME EXTRACTOR ARMS

levco

- An extractor arm extracts smoke, dust and gases directly at the source, before the contamination has spread in the premises and been inhaled
- Superior extraction arm and advanced design "Parallelogram" counter balancing system that eliminates the need for continual adjustment of friction joints and allows for an unparalleled ease of movement
- Ideal solution for most "source-capture" applications and specifically recommended for applications requiring an "easy to position" extractor that does not require constant adjustment
- Compact and smooth design, clearance of 1m (50") required
- **5-year limited warranty**

Flexi construction: Internal supporting mechanism made of mild steel tubing, 3 spring-assisted joints to provide precise counterbalancing of the extractor's inner and outer arm. Comes with a black baked-on enamel steel hood w/ optimized airflow and ring handle, and built in damper and with black baked-on enamel wall bracket. Motor and fan not included



EXTRACTOR ARMS

Description	Flexi I, 6.5" dia Model No.	Mfg. No.	Price /Each	Flexi II, 8" dia Model No.	Mfg. No.	Price /Each
7' (2 m) Extractor Arm w/Wall Bracket	BA660	P-007	1301.00	BA978	P-143	1692.00
10' (3 m) Extractor Arm w/Wall Bracket	BA661	P-008	1486.00	BA979	P-144	1885.00
14' (4 m) Extractor Arm w/Wall Bracket	BA662	P-009	1904.00	BA980	P-145	2442.00
17' (5 m) Extractor Arm w/Wall Bracket	BA663	P-010	2090.00	BA985	P-146	2694.00

MINI-FLEX

MINI FLEX DUAL HOSE MOUNT

- "At source" fume collector designed for soldering, TIG welding and other toxic applications
- The compact design ensures convenient mobility and features 2 flexible extractor arms that retain their position to source capture fume and gases before entering the operators breathing zone
- Easily mounted on top or just underneath a table (Tabletop would require two 3.5" diameter holes)

CONSTRUCTION:

- 16/18 ga. welded steel cabinet with white finish
- Filter access through top assembly
- ON/OFF rocker switch
- 2.5 m (8') long power cord
- Running light
- Acoustical silencing foam
- 200 Watt motor, 115/1/60Hz (0.85 amps),
- 1" poly prefilter, 99.97% HEPA filter, 1" charcoal filter,
- Two 42" fume extractor arms with aluminum hoods
- 12" L x 13" W x 20" H
- **5-year limited warranty**
- Always refer to owners manual before operating this type of equipment

FEATURES & BENEFITS:

- Light extraction arms - Easy to set into position above the process
- Compact design - Place directly on or below the work surface/table
- 3 stage filtration: Prefilter, HEPA and charcoal - Allow the unit to be used for a variety of applications
- High flow rate (300 CFM) - Capture fumes before they reach the operators breathing zone



levco

Model No.	Mfg. No.	Description	Price /Each
EA448	MINI-FLEX	Mini-Flex Dual Hose Mount	3687.00

KLETON

CANADA'S LEADING MATERIAL HANDLING SUPPLIER

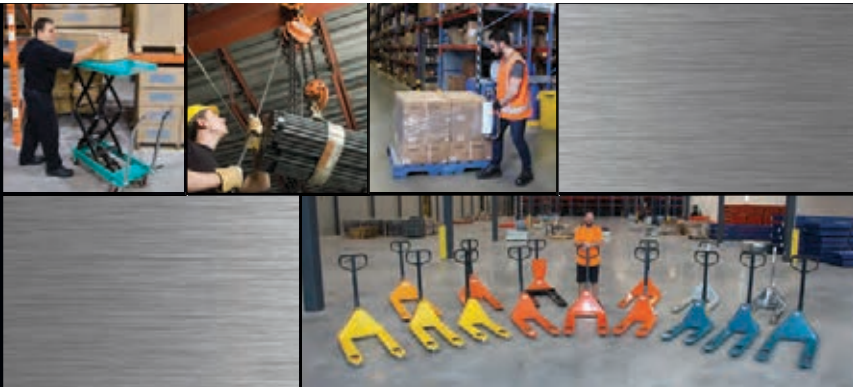

WELDING PROTECTION

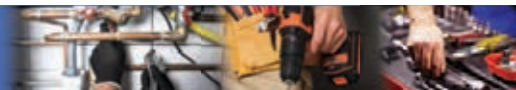

WELDING HELMETS

- Lightweight design with ratchet headgear
- Comes complete with shade 10 lens
- Choice of 2" x 4 1/4" flip front or 4 1/2" x 5 1/4" wide vision fixed front
- Passive lens
- Material: Thermoplastic



NT645



NT687



Model No.	Description	Window Dimensions"		Price /Each
NT645	Flip Front	2	x 4 1/4	29.95
NT687	Fixed Front	4 1/2	x 5 1/4	51.95

WH10 PASSIVE WELDING HELMETS

- Narrow shell design is perfect for work in tight space
- Extended front increases throat protection against sparks, slag and other physical hazards
- Comes standard with cover plate and shade 10 polycarbonate filter plate
- Meets ANSI standard Z87.1 and compliant with CSA standard Z94.3



SD617



PB193



Model No.	Mfg. No.	Description	Colour	Price /Each
PB193	14982	HSL-2 Helmet, 2" x 4 1/4", Flip Front	Black	115.00
SD617	14975	HSL-100 Helmet, 4 1/2" x 5 1/4", Fixed Front	Black	113.00

WH40 ELEMENT* ADF WELDING HELMETS

- Lightweight shell weighs only 6 oz.
- Available in two different auto-darkening filters: ADF fixed shade 10 and ADF variable shade 9-13
- Two independent arc sensors
- Solar powered unit
- Meets ANSI standard Z87.1 and compliant with CSA standard Z94.3



SEA769



Model No.	Mfg. No.	Description	Price /Each
SEA769	23282	Welding Helmet-Variable ADF, 4.33" x 3.54"	292.00
SEA771	29127	Replacement Cover Lens Kit - Includes 5 Front and 2 Rear Safety Plates	23.80
SED982	23442	Replacement Headgear	23.90

WH40 INSIGHT* VARIABLE ADF WELDING HELMETS

- Get the high-level elements of a high-performance welding lens without the high price
- Offers an ADF with digital and multi-function controls for any welding job
- Sensitivity and delay adjustments
- Four independent sensors
- Easy-to-use digital controls
- Torch, grind and weld modes
- Variable shade: 9-13
- Viewing area: 3.93" x 2.36"
- Meets ANSI standard Z87.1 and compliant with CSA standard



SDP562



Model No.	Mfg. No.	Description	Price /Each
SDP562	40710	HSL100 Black w/Insight* ADF	407.00
SDP563	40709	Insight* ADF Cartridge, 4.5" x 5.25"	361.00
SDP564	41594	Internal Lens, 10/Pkg.	28.60
SDP565	41589	Replacement Cover Lens Kit - 5 Front and 2 Rear Safety Plates	23.50

REBEL ADF WELDING MASK

- One-piece design protects against UV and IR leakage as well as spark and spatter penetration
- Engineered with the latest advancements in True Color technology
- Exclusive wrap-around face shield for added protection
- Compatible with prescription eyewear and Jackson Safety hard hats
- Hood is made using a high-performance flame-resistant fabric
- Easy-to-use digital ADF control system
- Battery life lasts up to 1300 hours (batteries replaceable)
- Meets or exceeds ANSI Z87.1, CAN/CSA Z94.3 standards and is CE certified
- Viewing Area: 3.5" L x 1.3" W
- Shade Level: 3/5-12



Model No.	Mfg. No.	Description	Price /Each
SGW859	46200	ADF Welding Mask	392.00
SHA441	46600	Replacement Fire-Resistant Hood	55.10

INSIGHT DIGITAL VARIABLE ADF WELDING HELMET

- Variable shade 9-13 to shield and protect eyes from radiant energy during weld
- Viewing area of 3.94"x2.36" offers unobstructed vision during each stage of the welding process
- Ultra-lightweight shell helps reduce neck tension
- Easy to use digital controls
- Sensitivity and delay adjustments
- Choose from Weld and Grind modes
- Four independent sensors reduce blockage possibility
- Solar assist provides additional energy source
- Lithium batteries with easy access
- Colour: Black



Model No.	Mfg. No.	Description	Price /Each
SHA433	46131	Welding Helmet-Variable ADF	407.00

FLEXIBLE FRAME GOGGLES

- Soft PVC frame seals out light leaks
- Choice of 2" x 4 1/4" fixed front or flip front design
- Comes complete with shade 5 lens



NT646



NT647



Model No.	Description	Price /Each
NT646	Fixed Front	8.95
NT647	Flip Front	11.25

Z1100 SERIES WELDING SAFETY GOGGLES

- Can be used over most prescription eyewear
- Wrap-around style provides excellent 180° panoramic vision
- Extremely flexible soft PVC goggle body for greater comfort
- Impact resistant polycarbonate lens
- Anti-fog lens is ideal for high humidity applications
- Indirect vent increases air flow and protects against dust, fumes and chemical splash
- Adjustable elastic headband
- Ventilation Type: Indirect
- Lens Coating: Anti-Fog
- Standard(s) Met: ANSI Z87+, CSA Z94.3



SGR808



Model No.	Lens Tint	Price /Each
SGR808	3.0	15.25
SGR809	5.0	18.15

V-MAXX™ GOGGLES

- Sport wrap-around style
- Direct vent for impact resistance and indirect vent for chemical splash applications
- OTG compatible
- 180° clear field of vision
- Lenses coated with Fog-ban® anti-fog coating
- Pivoting headband clips to adjust strap around hardhats or hearing protection
- Adjustable elastic or neoprene headband
- Certified to CSA standard Z94.3



SAI908



Model No.	Mfg. No.	Description	Lens Tint	Price /Each
SAI908*	11250850	Indirect Vent, Black Frame and Headband	Shade 5.0	26.40
SAI905*	11250800	Direct Vent, Red Headband	Clear, Fog-ban®	9.78
SAI906	11250810	Indirect Vent, Black Neoprene Headband	Clear, Fog-ban®	11.60

* Elastic Headband

CUP GOGGLES

- Rigid 2" (50 mm) round lens cup goggle
- Comes complete with shade 5 lens



Model No.	Price /Each
NT648	7.95

V80 WILDCAT* GOGGLES

- Extreme heat resistance, will not melt, drip or ignite at 350°F for five minutes
- Adjustable side vents to help increase airflow
- Fits naturally to the contour of your face
- Lightweight and comfortable with a pivot headband that allows for optimal placement
- Meets ANSI standard Z87.1+ and compliant with CSA standard Z94.3



TTT946



TTT947



TTT950



Model No.	Mfg. No.	Lens Tint	Price /Each
TTT946	20525	Clear Anti-Fog	21.30
TTT947	20526	Smoke Anti-Fog	21.00
TTT949	20528	Shade 3.0 Anti-Fog	33.80
TTT950	20529	Shade 5.0 Anti-Fog	34.90

V90 SHIELD* GOGGLES

- Features the Monogoggle® XTR* with indirect ventilation and a polycarbonate shield for full face protection
- Shield detaches from the goggles
- Curved face shield conforms to shape of face offering added protection
- Can be used over most prescription eyeglasses
- Meets ANSI impact standard Z87.1+



TTT955



TTT954



Model No.	Mfg. No.	Lens Tint	Price /Each
TTT954	18629	Clear Anti-Fog	34.90
TTT955	18631	Shade 3.0 Anti-Fog	48.80



WELDING & CUTTING OUTFITS

All Harris Classic outfits come complete with tool bag and include the following torch features: Solid forged head, brazed triangular tube design, ease-on cutting valve and protected torch union



Solid Forged Head



Brazed Triangular Tube Design



Ease-On Cutting Valve



Protected Torch Union

STEELWORKER® CLASSIC WITH TOOL BAG

- Cuts to 5" and welds to 1/2" with larger tips

Includes:

- Torch handle (85)
- Mixer (D-85)
- Cutting attachment (72-3)
- Cutting tip (6290-1AC)
- Welding tip (23A90-5)
- Single stage 0-100 PSIG oxygen regulator
- Single stage 0-15 PSIG fuel gas regulator
- 20' x 3/16" hose
- Goggles
- Striker

Model No. TTU521
Mfg. No. 4403224
Price/Each \$815.00



TTU521



PIPELINER® CLASSIC WITH TOOL BAG

- Cuts to 6" and welds to 1" with larger tips

Includes:

- Torch handle (43-2)
- Mixer (E-43)
- Cutting attachment (73-3)
- Cutting tip (6290-1AC)
- Welding tip (23A90-5)
- Single stage 0-125 PSIG oxygen regulator
- Single stage 0-15 PSIG fuel gas regulator
- 20' x 1/4" hose
- Goggles
- Striker

Model No. TTU520
Mfg. No. 4403235
Price/Each \$1169.00



TTU520



IRONWORKER® MEDIUM-DUTY WITH TOOL BAG

- Cuts to 5" and welds to 1/2" with larger tips

Includes:

- Torch handle (85) Mixer (D-85)
- Cutting attachment (72-3)
- Cutting tip (6290-1AC)
- Welding tip (23A90-5)
- Single stage 0-100 PSIG oxygen regulator
- Single stage 0-15 PSIG fuel gas regulator
- 20' x 1/4" hose
- Goggles
- Striker

Model No. TTV225
Mfg. No. 4400366
Price/Each \$685.00



TTV225



PORT-A-TORCH® OUTFITS

- All outfit components are industrial grade for professional use
- Cutting attachments feature solid forged heads, triangular stainless steel tubes with brazed connections, solid brass forged levers and a lock ring that secures torch nut in place
- Torch handles feature silver-brazed, twin-tube construction and easily replaceable Flashguard® check valves
- Regulators equipped with an encapsulated Teflon® seat for safety and extended service life

- Includes:** Welding tip (23A90-3), Fuel gas regulator (601-15-200), Oxygen regulator (601-80-540), 3/16" x 12' hose, 20 cu. ft. oxygen cylinder, 10 cu. ft. "MC" acetylene cylinder, cylinder wrench, goggles, striker and instruction manual
- Tool bag not included

Model No.	Mfg. No.	Description	Torch Handle	Cutting Attachment	Mixer	Cutting Tip	Price /Each
TTU624	4403211	Classic Style	85	72-3	D-85	6290-1AC	1239.00



LIGHT/MEDIUM DUTY TOTE-A-TORCH OUTFITS

- For use in general repair, maintenance and HVAC applications
- Can weld up to 3/16" and cut up to 1/2"
- Rear entry regulators provide better balance
- Acetylene regulator has an MC CGA200 inlet connection; oxygen regulator has standard CGA540 connection

Includes:

- Torch handle with check valve
- Cutting attachment
- Oxygen/acetylene regulators with 2" double-scale gauges
- Cutting tip
- Welding nozzle
- 12.5' twin hose
- Goggles
- Striker
- Tank wrench
- Cylinders
- Polypropylene carrier

Model No. TTT892
Mfg. No. 72-PTC
Price/Each \$1249.00



PROWELD
 by **GENTEC**

TOTE-A-TORCH OUTFITS

- Light-to-medium duty portable outfit
- Welds up to 3/16" and cuts up to 1/2"
- Rear entry regulators for better balance
- Acetylene regulator has an "MC" (CGA 200) inlet connection; oxygen regulator has standard CGA 540 connection
- Victor® portable torch or Super Range® compatible

Includes:

- Torch handle (142T)
- Cutting attachment (142C)
- Regulators (210X-80/210Y-15)
- Cutting tip (172C-0)
- Welding nozzle (172W-1)
- 12.5' twin hoses
- Goggles
- Striker
- Plastic carrier
- One "MC" acetylene cylinder
- One "R" oxygen cylinder

Model No. 331-1070
Mfg. No. 12-PTC
Price/Each \$1369.00



GENTEC
 GENSTAR TECHNOLOGIES

HOTSPOTTER ALL-PURPOSE PROPANE HEAVY-DUTY TORCH KITS

- All-purpose propane flame tool operates off the pressure of a standard propane tank – no regulator required
- 31" handle
- Ideal for a wide variety of all-season maintenance/repair applications
- Burns weeds, repairs asphalt, seals tar, peels paint, removes road markings, melts ice and thaws pipe
- 500000 BTU rating
- **Includes:**
 - 10' neoprene hose
 - On/off valve
 - Durable cast iron and steel nozzle
 - Striker

WESTERN
 ENTERPRISES



Model No.	Mfg. No.	Price /Each
312-4904	WB-101	144.00

SILVER MEDIUM-DUTY WELDING & CUTTING OUTFITS

- Can weld up to 1/4" and cut up to 1/2"
- Ideal general purpose kit for construction, facility maintenance, petroleum and chemical industries
- Victor® Cutskill® compatible
- Comes in environmentally-friendly packaging for easy transportation

Includes:

- Torch handle with check valve
- Cutting attachment
- Oxygen/acetylene regulators with 2" double-scale gauges
- Cutting tip #0
- Welding nozzle #2
- T-Grade 17.5' twin hose
- Goggles
- Striker

Model No. TTV021
Mfg. No. 7120
Price/Each \$599.00



GENTEC
 GENSTAR TECHNOLOGIES

SILVER HEAVY-DUTY WELDING & CUTTING OUTFITS

- Can weld up to 1/2" and cut up to 3/4"
- Ideal for industrial and commercial applications
- Victor® Cutskill® compatible
- Comes in environmentally-friendly packaging for easy transportation

Includes:

- Torch handle with check valve
- Cutting attachment
- Oxygen/acetylene regulators with 2 1/2" double-scale gauges
- Cutting tip #1
- Welding nozzle #2
- T-Grade 17.5' twin hose
- Goggles
- Striker

Model No. TTV022
Mfg. No. 7130
Price/Each \$795.00



GENTEC
 GENSTAR TECHNOLOGIES

OXY-FUEL THE SMALL TORCH™ KITS

- Designed for plumbing, HVAC, refrigeration and jewelry manufacturing and repair
- Braze and solder material from the tiniest up to 1/8" thick steel
- Melts up to 3 oz silver
- Provides stable and precise concentrated feather flame up to 6000°F for various material such as metals, ceramics and glass

Includes:

- Torch handle (10ST)
- Tips (10STP2 – 6)
- Hose
- Oxy/fuel regulators (where applicable)



333-102201209

333-102201204

GENTEC
 GENSTAR TECHNOLOGIES

Model No.	Mfg. No.	Description	Price /Each
333-102201204	GKSTA06	Kit w/o Regulators	295.00
333-102201209	GKSTA16	Kit with Oxy/Fuel Regulators	879.00

WELDING & METALWORKING



CLASSIC TORCH HANDLES NO. 43-2

- High capacity combination handle
- Stainless steel head
- Equipped with FlashGuard® check valves
- Capacity: cuts 6", welds to 1"
- 9 1/2" length

Model No. TTT898
Mfg. No. 1401150
Price/Each \$289.00



CLASSIC TORCH HANDLES NO. 85

- Silver brazed twin tube construction for safety and durability
- Equipped with FlashGuard® check valves
- Capacity: cuts 5", welds to 1/2"
- 8 1/2" length

Model No. TTT899
Mfg. No. 1401340
Price/Each \$219.00



CLASSIC CUTTING ATTACHMENTS

- Solid forged head resists abuse and distortion
- Triangular tube design is compact and lightweight with exceptional strength and rigidity
- Brazed connections prevents leaks
- Protected torch union nut protects seals and O-rings from abuse
- Solid forged lever for exceptional strength
- Ease-on cutting oxygen control for smoother starts
- 90° torch head angle

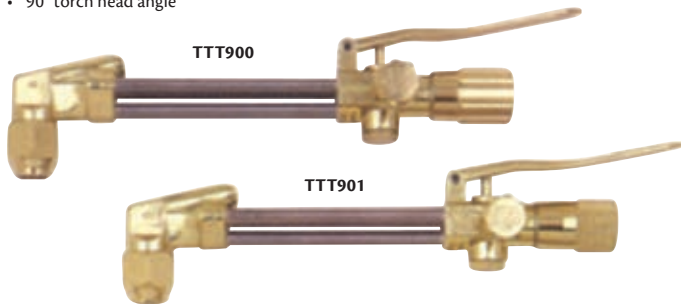

Model No.	Mfg. No.	Uses Torch Head	Price/Each
TTT900	1300340	43-2	289.00
TTT901	1300380	85	219.00

HAND CUTTING TORCHES

- The industry standard by which all other designs are compared!
- Cuts to 12"
- Solid forged head
- Triangular tube design
- Brazed connections
- Equipped with FlashGuard® check valves
- Choice of positive pressure "E" Torches for acetylene and alternate fuels, and low pressure "F" Injector Torches for maximum performance with alternate fuels such as propane, natural gas, MAPP® gas, and propylene

Note: "F" torches are NOT FOR USE with acetylene



Model No.	Mfg. No.	Head Angle°	Length"	Price/Each
POSITIVE PRESSURE "E" TORCHES				
TTT902	1003464	70	21	689.00
TTT903	1003440	90	21	689.00
TTT904	1003351	70	36	975.00
TTT905	1003441	90	36	975.00
LOW PRESSURE "F" INJECTOR TORCHES				
TTT906	1003370	70	21	689.00
TTT907	1003470	90	21	689.00
TTT910	1003400	70	36	929.00
TTT911	1003480	90	36	929.00

HARRIS® INFERNO® AIR FUEL ACETYLENE KITS & TIPS

- Brazing and soldering without oxygen
- Hottest air fuel tip available
- Compatible with all competitive quick connect air fuel torches
- Results in faster brazing and soldering
- Precision manufactured for the best flame on the market today
- Kit includes: Quick connect handle, regulator (CGA 520), tip (TTU646) and hose
- Every tip made in USA by Harris® to exacting standards

Model No. TTU641
Mfg. No. 4400085
Price/Each \$579.00

TTU641



TTU646



ACETYLENE TIPS

Model No.	Mfg. No.	Tip"	Gas Flow @ 14 PSI SCFH	Soft Solder"	Brazing"	Price /Each
TTU645	1601110	1/4	3.10	Up to 1	Up to 1/2	155.00
TTU646	1601111	5/16	5.80	3/4 - 1 1/2	1/4 - 3/4	179.00
TTU647	1601112	3/8	6.60	1 - 2	1/2 - 1	195.00
TTU648	1601113	7/16	9.80	1 1/4 - 3	7/8 - 1 5/8	209.00

STRAIGHT CUTTING V242 HAND CUTTING TORCHES

- Victor® compatible medium-duty torch
- Designed for use with all fuel gases
- Cutting Capacity: 6"
- Uses Victor® series 1 tips
- Features stainless steel cutting lever, ease on cutting valve, triangular tube design and Flashguard® check valves
- Equal pressure mixer
- UL listed
- Meets CGA E.5 standards

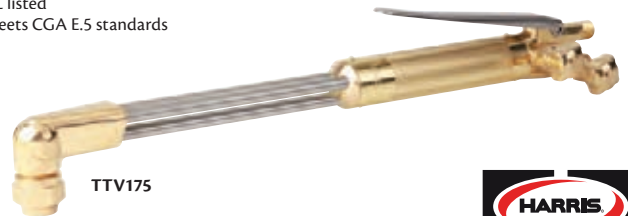

TTV175



Model No.	Mfg. No.	Head Angle°	Length"	Price /Each
TTV175	1004639	70	18	489.00
TTV176	1004618	90	18	465.00
TTV177	1004637	70	21	489.00
TTV178	1004603	90	21	465.00

SINGLE STAGE REGULATORS NO. 25

- One-piece encapsulated seat design with an internal filter and a PTFE Teflon® seat
- Chrome-plated bonnet with forged brass body
- 2" dual scale gauges
- Gauge guards sold separately



TTT922



Model No.	Mfg. No.	Gas	Max Inlet Pressure, PSIG	Delivery Pressure Range, PSIG	Delivery Pressure Gauge, PSIG	Supply Pressure Gauge, PSIG	Inlet Connection	Outlet Connection	Price /Each
TTT920	3000380	Acetylene	500	0-15	30	400	CGA510	9/16"-18 LH	265.00
TTT921	3000450	Propane*	500	0-50	60	400	CGA510P	9/16"-18 LH	265.00
TTT922	3000510	Oxygen	3000	0-100	150	4000	CGA540	9/16"-18 RH	265.00
TTT923	3000540	Ar, N ₂ , He	3000	0-100	150	4000	CGA580	9/16"-18 RH	265.00
TTT924	3000550	Industrial Air	3000	0-100	150	4000	CGA590	9/16"-18 RH	265.00
TTT925	3000806	N ₂	3000	0-200	400	4000	CGA580	9/16"-18 RH	359.00

*Regulator designated for propane service can be used with any of the other welding grade liquid petroleum gases. NOT FOR USE WITH ACETYLENE.

152 SERIES - SINGLE STAGE REGULATORS

- Designed for medium-duty gas welding, cutting and heating applications
- Body and housing cap are machined from class "A" brass bar stock
- Self re-seating external safety pressure relief valve on oxygen models
- Stem type seat assembly for more reliable performance
- 2" gauges for easy reading
- 2" diaphragm
- UL listed



Model No.	Mfg. No.	Gas Service	Max Inlet/Delivery Pressure (PSI)	Inlet Gauge	Outlet Gauge	Inlet Connection	Outlet Connection	Price /Each
331-3575	152X-80	Oxygen	3000/4-80	2", 4000 PSI	2", 100 PSI	CGA540	9/16"-18 RH (M)	249.00
331-3585	152Y-15	Acetylene	400/2-15	2", 400 PSI	2", 30 PSI, RL	CGA510	9/16"-18 LH (M)	249.00

153 SERIES - SINGLE STAGE REGULATORS

- Designed for heavy-duty gas welding, cutting and heating applications
- 2 1/2" gauges for easy reading
- 3 1/4" stainless steel diaphragm for accurate pressure delivery
- Delrin cap bushing for smooth adjustments
- Stem type seat assembly for more reliable performance
- Body and housing cap machined from class "A" brass bar stock
- Self re-seating external pressure relief valve on oxygen model
- Sintered bronze inlet filter
- UL listed



Model No.	Mfg. No.	Gas Service	Max Inlet/Delivery Pressure (PSI)	Inlet Gauge	Outlet Gauge	Inlet Connection	Outlet Connection	Price /Each
331-3665	153X-125	Oxygen	3000/5-125	2 1/2", 4000 PSI	2 1/2", 200 PSI	CGA540	9/16"-18 RH (M)	485.00
331-3675	153Y-15	Acetylene	400/2-15	2 1/2", 400 PSI	2 1/2", 30 PSI, RL	CGA510	9/16"-18 LH (M)	485.00

452 SERIES - SINGLE STAGE REGULATORS

- Designed for medium to heavy-duty gas welding, cutting and heating applications; the "Horse" is a Harris® style regulator
- 2 3/4" diaphragm and a Victor® style seat mechanism
- Forged brass body
- Self re-seating external pressure relief valve on oxygen, inert gases and carbon dioxide models
- Sintered bronze inlet filter
- 2" gauges for easy reading
- Chrome plated housing cap
- UL listed



Model No.	Mfg. No.	Gas Service	Max Inlet/Delivery Pressure (PSI)	Inlet Gauge	Outlet Gauge	Inlet Connection	Outlet Connection	Price /Each
331-4385	452X-80	Oxygen	3000/4-80	2", 4000 PSI	2", 100 PSI	CGA540	9/16"-18 RH (M)	239.00
331-4380	452X-175	Oxygen	3000/5-175	2", 4000 PSI	2", 300 PSI	CGA540	9/16"-18 RH (M)	229.00
331-4395	452Y-15	Acetylene	400/2-15	2", 400 PSI	2", 30 PSI, RL	CGA510	9/16"-18 LH (M)	239.00
TTT120	452C-175	Carbon Dioxide	3000/5-175	2", 4000 PSI	2", 300 PSI	CGA320	5/8"-18 RH (F)	239.00
331-4285	452C-300	Carbon Dioxide	3000/20-300	2", 4000 PSI	2", 400 PSI	CGA320	5/8"-18 RH (F)	385.00
TTT118	452N-80	Inert Gases*	3000/4-80	2", 4000 PSI	2", 100 PSI	CGA580	5/8"-18 RH (F)	239.00
331-4340	452N-300	Inert Gases*	3000/20-300	2", 4000 PSI	2", 400 PSI	CGA580	5/8"-18 RH (F)	329.00
804-1975	452N-450	Inert Gases*	3000/30-450	2", 4000 PSI	2", 600 PSI	CGA580	5/8"-18 RH (F)	355.00

*Argon, nitrogen, helium



153 SERIES – GAUGE PROTECTORS

- Durable metal construction
- Reduces potential damage to pressure gauges
- Easy to install and remove from regulators
- For use with Gentec® 153 Series regulators, interchangeable with other major brands

Note: Gauge protectors are not designed to replace or alleviate the need for proper cylinder storage systems. Cylinders should always be used and stored in conjunction with local and OSHA requirements.



Model No.	Mfg. No.	Description	Price/Each
TTT893	GP31X	Oxygen Gauge Protector	30.90
TTT894	GP31Y	Acetylene Gauge Protector	30.90



TTT893



TTT894

190 SERIES - FLOW GAUGE REGULATORS

- "MIG METER" flow gauge regulators are designed for MIG and TIG applications
- 2" gauges for easy reading
- Accurate measurement of gas flow up to 50 SCFH
- Body machined from class "A" brass bar stock
- Chrome-plated housing cap
- Internal safety pressure relief design
- Plastic adjustment knob for smooth "easy touch" flow settings
- UL listed



Model No.	Mfg. No.	Gas Service	Max Inlet/Delivery Pressure (PSI)	Inlet Gauge	Outlet Gauge	Inlet Connection	Outlet Connection	Price /Each
331-1540	190AR-50	Argon	0-50	2", 4000 PSI	2", 50 SCFH	CGA580	5/8"-18 RH (F), 0.32" Orifice	205.00
331-1575	190CD-45	Carbon Dioxide	0-45	2", 4000 PSI	2", 50 SCFH	CGA320	5/8"-18 RH (F), 0.32" Orifice	205.00



191 SERIES - FLOWMETER REGULATORS

- Designed for MIG and TIG applications
- Provides accurate regulation of gas flow
- Piston type construction
- Body machined from class "A" brass bar stock
- Polycarbonate flow tube and outer cover are impact resistant
- Conforms to CGA E-4 standard for gas pressure regulators



Model No.	Mfg. No.	Gas Service	Flow Capacity (SCFH)	Inlet Gauge	Flowmeter (SCFH)	Inlet Connection	Outlet Connection	Price /Each
331-1610	191AR-60	Argon	50	1 1/2", 4000 PSI	60	CGA580	5/8"-18 RH (M)	249.00
TTT131	191CD-60	Carbon Dioxide	50	1 1/2", 4000 PSI	60	CGA320	5/8"-18 RH (F)	259.00

WITH 6-FOOT HOSE INCLUDED

331-4150	191AR-60-6HSP	Argon	50	1 1/2", 4000 PSI	60	CGA580	5/8"-18 RH (M)	295.00
331-3200	191CD-60-6HSP	Carbon Dioxide	50	1 1/2", 4000 PSI	60	CGA320	5/8"-18 RH (F)	319.00



195 SERIES - "MIG MASTER" FLOWMETER REGULATORS

- Designed for MIG and TIG applications and provide accurate regulation of gas flow
- Provides reliable performance in commercial, industrial and lab applications
- Single stage construction
- 0-60 SCFH argon (Ar) flow, 0-150 SCFH helium (He) flow, 0-60 SCFH carbon dioxide (CO₂) flow
- Polycarbonate flow tube and outer cover are impact resistant for maximum durability and service life
- Flowmeter is backpressure compensated to ensure accurate readings when line restrictions are present
- 2" high-pressure gauge for easy reading
- Body machined from class "A" brass bar stock
- Chrome-plated housing cap
- Internal safety pressure relief design
- Sintered bronze inlet filter
- UL listed



Model No.	Mfg. No.	Gas Service	Outlet Pressure Preset (PSI)	Inlet Gauge	Flowmeter (SCFH)	Inlet Connection	Outlet Connection	Price /Each
331-1638	195AR-60	Argon	50	2", 4000 PSI	60	CGA580	5/8"-18 RH (F)	345.00
331-4166	195AR-60-680	Argon	50	2", 6000 PSI	60	CGA680	5/8"-18 RH (F)	355.00
331-4175	195CD-60	Carbon Dioxide	50	2", 4000 PSI	60	CGA320	5/8"-18 RH (F)	355.00



195FM SERIES - FLOWMETERS

- Designed for accurate regulation of gas flow
- Backpressure compensated design insures accurate readings when line restrictions are present
- Polycarbonate flow tube is square shaped for easy reading
- Body machined from class "A" brass bar stock
- Easy adjustment brass knob for "fine-tune" flow settings
- UL listed



Model No.	Mfg. No.	Gas Service	Max Inlet Preset (PSI)	Inlet Connection	Outlet Connection	Flowmeter Flow Range (SCFH)	Price /Each
331-4185	195FM	Argon, Carbon Dioxide	50	1/4" NPT(M)	5/8"-18 RH(F)	0-60 Ar	195.00



198CD ELECTRICALLY HEATED REGULATORS/ FLOWMETERS FOR CARBON DIOXIDE

- Designed for applications requiring extremely high gas flow rates
- Built-in, thermostatically-controlled electric heater keeps the carbon dioxide warm, allowing for continuous duty cycle without freezing
- 110 VAC/190 W heater is standard
- 0-60 SCFH flowmeter is backpressure compensated to ensure accurate reading when line restrictions are present
- Forged brass body and housing cap with sintered bronze inlet filter

Caution: Use this regulator only with non-siphoned standard carbon dioxide cylinders



Model No.	Mfg. No.	Gas Service	Max Delivery Pressure (PSI)	Inlet Gauge	Flowmeter (SCFH)	Inlet Connection	Outlet Connection	Price /Each
331-4210	198CD-60	Carbon Dioxide	50 (Preset)	2", 4000 PSI	60	CGA320	5/8"-18 RH(F)	675.00



BRASS PRESSURE GAUGES

- Dual scale
- Lexan™ cover lens
- 1/4" NPT inlet



Model No.	Description	Price /Each
NT616	2" x 100 PSI	13.35
NT618	2" x 30 PSI – Red line	13.35
NT619	2" x 400 PSI	13.35
NT620	2" x 4000 PSI	15.35
NT622	2 1/2" x 200 PSI	16.90
NT623	2 1/2" x 30 PSI – Red line	16.90
NT624	2 1/2" x 400 PSI	15.35
NT625	2 1/2" x 4000 PSI	15.35



STEEL PRESSURE GAUGES

- Dual scale
- Lexan™ cover lens



Model No.	Mfg. No.	Scale Ranges	Entry Type	Price /Each
1 1/2" STEEL CASE, 1/8" NPT INLET				
331-2980	G15-030RL	0-30 PSI – Red Line	Side	16.90
331-2985	G15-100	0-100 PSI	Side	16.90
331-2990	G15-400	0-400 PSI	Side	16.90
331-2995	G15-4000	0-4000 PSI	Side	20.50
331-2445	GR15-4000	0-4000 PSI	Rear	21.50
2" STEEL CASE, 1/4" NPT INLET				
331-2405	G20-050CF	0-50 SCFH	Side	16.90



TOOLS THAT MEASURE UP!

AURORA TOOLS



CUTTING TIP CHART

MATERIAL THICKNESS	1/8	1/4	1/2	3/4	1	1-1/2	2	4	5	6	8	10	12
RECOMMENDED TIP NUMBER AND DRILL SIZE	00 / 68	0 / 60	1 / 56	1 / 56	2 / 54	2 / 54	3 / 52	3 / 49	4 / 44	6 / 38	6 / 31	7 / 28	8
OXYGEN PRESSURE SETTING LB/IN ² g	20-25	25-30	30-35	30-35	35-40	40-45	40-45	40-50	45-55	45-55	45-55	45-55	45-55
ACETYLENE PRESSURE SETTING LB/IN ² g	3-5	3-5	3-5	3-5	3-7	3-7	5-10	5-10	6-12	7-13	8-14	10-15	10-15
CUTTING IN / MIN	27-30	26-29	20-24	17-21	14-18	13-17	12-15	8-11	7-9	6-8	5-6	4-5	3-4

AIRCO® 144/ALC 802 STYLE CUTTING TIPS

- For general hand or machine cutting
- Acetylene-oxygen
- Medium preheat
- Fits Airco® 3790, 4690, 4700, 4800, 5700, 5800, 1100, 3000, 9000 and 9500 torches

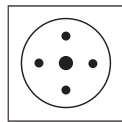

Model No.	Size	Price/Each
TTU465	00	21.44
TTU466	0	21.44
TTU467	1	21.44
TTU468	2	21.44
TTU469	3	21.44
TTU470	4	21.44
328-1351	5	18.59

AIRCO® 164/ALC 803 STYLE CUTTING TIPS

- For general, cast iron and stainless steel cutting
- Acetylene-oxygen
- Very high preheat
- Fits Airco® 3790, 4690, 4700, 4800, 5700, 5800, 1100, 3000, 9000 and 9500 torches



Model No.	Size	Price/Each
TTU471	00	21.44
TTU358	0	21.55
TTU359	1	21.55
TTU360	2	21.55
TTU361	3	21.55
TTU362	4	21.55
TTU472	5	21.55
TTU473	6	21.44
TTU474	7	21.44
328-1468	8	20.49

AIRCO® 261/ALC 829 STYLE CUTTING TIPS

- For general cutting, two-piece tip for hand cutting
- Propane or oxygen-natural gas
- High preheat
- Fits Airco® 2900, 3790, 4690, 4700, 4800, 5700, 5800, 1100, 3000, 9000 and 9500 torches



Model No.	Size	Price/Each
TTU475	0	22.18
TTU476	1	22.18
TTU477	2	22.18
TTU478	3	22.18
TTU479	4	22.18
TTU480	5	22.18
328-1702	6	26.09

PUROX® 4202/ESAB STYLE CUTTING TIPS

- For general cutting
- Acetylene-oxygen
- Medium preheat
- Fits CW-200, CW-202, CW-300 Type E torches and C-205 machine torch

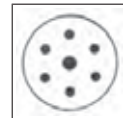

Model No.	Size	Price/Each
TTU481	3	19.37
TTU482	4	19.37
TTU483	5	19.37
TTU484	7	19.37
TTU485	9	19.37

SMITH® MC12 STYLE CUTTING TIPS

- For hand cutting with oxy-acetylene
- Medium preheat
- Fits Smith® cutting assemblies MC505, MC509, AC305, and AC309

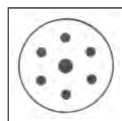

Model No.	Size	Price/Each
TTU530	1	28.48

SMITH® SC12 STYLE CUTTING TIPS

- For hand or machine cutting with oxy-acetylene
- Medium preheat
- Fits Smith® cutting attachments Silver Star and MC40
- Fits Smith® cutting torches Tuf Tony and Silver Star
- Fits Smith® machine torches SC770, SC771, SC780A, SC781A and SC782A



Model No.	Size	Price/Each
TTU531	1	28.47

Manufacturers names are used descriptively only to identify products with which these Replacement Tips may be used. They have no relationship with other manufacturers listed.



HARRIS® 6290 STYLE CUTTING TIPS

- For general hand cutting
- Acetylene-oxygen
- Medium preheat
- Fits Harris® 42-3, 62-3, 72, 72A, 73, 73A and 85 torches

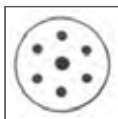

Model No.	Size	Price/Each
TTU458	000	14.95
TTU459	00	14.95
TTU349	0	14.95
TTU350	1	14.95
TTU351	2	14.95
TTU352	3	14.95
TTU460	4	14.95
TTU461	5	14.95
TTU462	6	14.95

HARRIS® 6290-NX STYLE CUTTING TIPS

- For general hand cutting
- Propane or oxygen-natural gas
- Medium preheat
- Fits Harris® 42-3, 49AF, 49F, 62-3, 72, 73, 85 and 142 torches



Model No.	Size	Price/Each
TTU463	000	15.49
328-2125	00	12.99
TTU353	0	15.49
TTU354	1	15.49
TTU355	2	15.49
TTU356	3	15.49
TTU357	4	15.49
TTU464	5	15.49

Manufacturers names are used descriptively only to identify products with which these Replacement Tips may be used. They have no relationship with other manufacturers listed.

VICTOR® 3-101 STYLE CUTTING TIPS

- For general hand cutting
- Acetylene-oxygen
- Medium preheat
- Fits CA 1260, CA 1350, C 1450, CA 2060, CST 800 and C 1400 torches

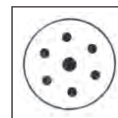

Model No.	Size	Price/Each
TTU448	000	14.53
TTU449	00	14.53
TTU340	0	14.53
TTU341	1	14.53
TTU342	2	14.53
TTU343	3	14.53
TTU450	4	14.53
TTU451	5	14.53

VICTOR® 1-118 STYLE CUTTING TIPS

- For gouging, scarfing and deseaming
- Acetylene-oxygen
- Fits 2460, CA 1060, ST, SST and 1400C torches

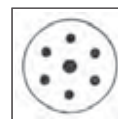

Model No.	Size	Price/Each
TTU445	2	35.68
TTU446	4	35.68
TTU447	6	39.08

VICTOR® 3-GPN STYLE CUTTING TIPS

- For general cutting
- Propane or oxygen-natural gas
- Medium preheat series 3 tip
- Fits CA 1260, CA 1350, C 1450, CA 2060, CST 800 and C 1400 torches



Model No.	Size	Price/Each
TTU454	0	14.27
TTU455	1	14.27
TTU456	2	14.27
TTU457	3	14.27

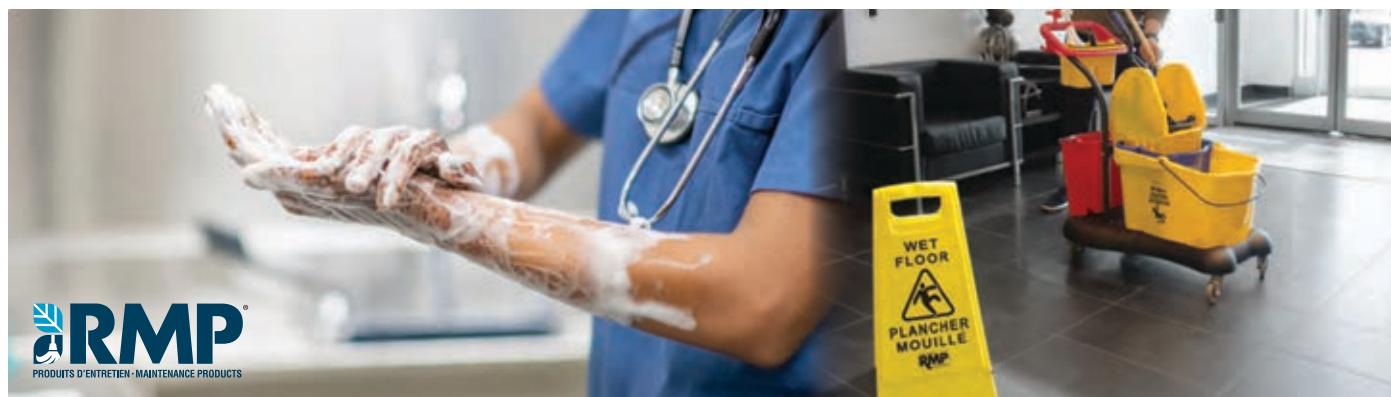



SPIRAL TIP CLEANERS

- Cleaning data on back of case
- Hardened steel file included in each case
- Quality aluminum case
- Includes 12 cleaners

Model No. NT641
Price/Each \$2.85



TIP DRILL KITS

- Cleans cutting tips and a variety of other fuel orifices and injectors
- Includes 12 drills in sizes 52-74
- Promotes more effective fuel use and increases performance in welding, cutting and heating tips
- Drills store neatly in pipe vise handle
- Includes Tip Sizes: #74 (0.5mm), #72 (0.6mm), #70 (0.7mm), #68 (0.8mm), #66 (0.8mm), #64 (0.9mm), #62 (0.9mm), #60 (1mm), #58 (1.1mm), #56 (1.2mm), #54 (1.4mm), #52 (1.5mm)

Model No. NT660
Price/Each \$9.95



WELD FILLET GAUGES

- Precision gauge
- Covers eleven sizes from 1/8", 3/16", 1/4", 5/16", 3/8", 7/16", 1/2", 5/8", 3/4", 7/8" and 1"
- Constructed of rust proof 22 gauge, type 304 steel
- Die blanked to eliminate sharp edges - adds to accuracy
- Permanently etched and black filled lettering for long life and abrasion resistance

Model No. TTV488
Price/Each \$45.50



TIP-NIP TIP REFACERS

- For easy, fast precision tip resurfacing
- Insert tip and give a few turns
- Pitted tip is resurfaced for new performance
- Extends tip life

Model No. NT820
Price/Each \$24.25



FLINT LIGHTERS

- Choice of single or three-flint lighters
- Additional flints sold separately

NT642



TTU071



NT663



Model No.	Description	Price/Each
NT642	Single Flint Lighter	3.10
TTU432	Single Flint Lighter w/ 5 Flint Holders	11.40
NT663	Flints, 5 per Holder	2.10
TTU071	Three-Flint Lighter	3.75
TTU072	Flints - Each	1.00

TTU072

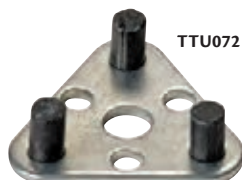

10-WAY CYLINDER WRENCHES

- For regulators, torches and commercial acetylene cylinders
- Drop-forged, special alloy steel for maximum durability
- Baked powder coat finish

Model No. BZ944
Mfg. No. D1013
Price/Each \$11.50



TANK KEYS

- For B and MC acetylene valves, double ended

Model No. TTU322
Mfg. No. B-MC
Price/Each \$0.74



QUICK-CONNECTS FOR WELDING EQUIPMENT

Western's Quick-Connects provide fast, reliable and positive connections and quick disconnections for torches, hoses and regulators. All models are color-coded for gas service for added safety (oxygen/green, fuel gas/red, inert gas/blue). Oxy/fuel gas models include integral reverse flow Check Valves. Quick-Connects fit all B-size welding and cutting equipment.

FEATURES & SPECIFICATIONS:

- Brass construction provides long service life— cycle tested over 10 000 operations indicating a service life of 10 to 12 years of comparable use
- Non-interchangeable Oxygen and Fuel Gas connectors prevent accidental gas mixing
- Instant closure on reverse flow Check Valves with total shutoff at only 10 oz. of back pressure
- Exceed CGA flow specifications—1100 SCFH flow at 125 PSIG inlet pressure and 800 SCFH flow at 125 PSIG inlet pressure when 2 additional check valves are used in conjunction with the Quick-Connects
- Spring loaded locking mechanism responds to fingertip action and achieves a gas-tight connection
- For inert gas models, demand valve on supply side creates a positive seal when fitting is not connected
- Double seal socket connection on second seal provides added safety protection
- 200 PSIG maximum operating pressure



QUICK CONNECT SETS

Model No.	Mfg. No.	Description	Components	Price/Each
312-4276	QDB10	Torch-to-Hose Set w/Check Valves	QDB11—Fuel Gas/QDB12—Oxygen/Inert	80.50
312-4280	QDB20	Hose-to-Hose Set w/Check Valves	QDB21—Fuel Gas/QDB22—Oxygen/Inert	84.70
312-4284	QDB30	Regulator-to-Hose w/Check Valves	QDB31—Fuel Gas/QDB32—Oxygen	84.70

QUICK-CONNECTS INDIVIDUAL UNITS

Model No.	Mfg. No.	Description	Components	Price/Each
TORCH-TO-HOSE				
312-4277	QDB11	Fuel Gas w/Check Valve	QDB200—Male Plug/QDB201—Female Socket	44.50
312-4278	QDB12	Oxygen/Inert Gas w/Check Valve	QDB100—Male Plug/QDB101—Female Socket	44.50
HOSE-TO-HOSE				
312-4281	QDB21	Fuel Gas w/Check Valve	QDB205—Male Plug/QDB201—Female Socket	44.60
312-4282	QDB22	Oxygen/Inert Gas w/Check Valve	QDB105—Male Plug/QDB101—Female Socket	44.60
REGULATOR-TO-HOSE				
312-4285	QDB31	Fuel Gas w/Check Valve	QDB205—Male Plug/QDB206—Female Socket	44.60
312-4286	QDB32	Oxygen w/Check Valve	QDB105—Male Plug/QDB106—Female Socket	46.40
312-4287	QDB33	Inert Gas—Regulator-to-Hose	QDB300—Male Plug/QDB301—Female Socket	44.50
312-4290	QDB34	Inert Gas—Hose-to-Machine	QDB302—Male Plug/QDB303—Female Socket	44.50

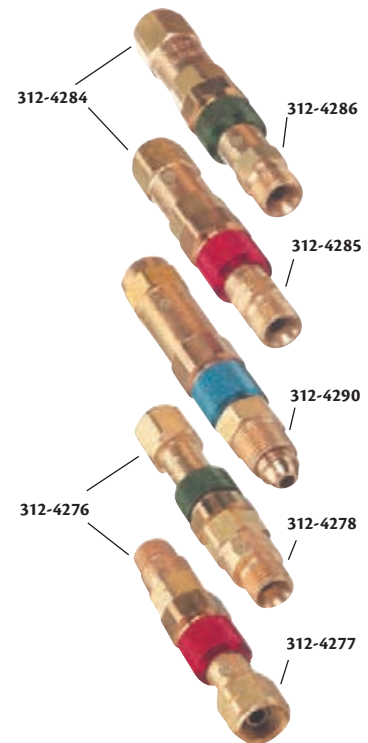

FLASHBACK ARRESTORS – OXY/FUEL GAS

Welders rely on Western's advanced Flashback Arrestors to help prevent serious incidents caused by reverse gas flows or flashbacks. Western's Flashback Arrestors are designed to stop flashbacks by preventing ignition of mixed gases and to protect equipment such as hoses, regulators and cylinders.

FEATURES & SPECIFICATIONS:

- Color-coded for gas service to provide added safety – oxygen (green), fuel gas (red)
- Internal check valves designed to prevent reverse flow and accidental mixing of oxygen and fuel gases
- Maximum operating pressures are 15 PSIG for acetylene, 22 PSIG for other fuel gases, and 125 PSIG for oxygen
- Rated capacity of 40 SCFH with a 5 PSIG pressure drop
- Torch and regulator models provide downstream and upstream protection
- 10" maximum cutting capacity
- Reusable; manual resetting not required
- UL listed and 100% tested



Model No.	Mfg. No.	Description	Components	Price/Each
312-3376	FA-10	Flashback Arrestor Set, Torch Style	FA-100P, FA-200P	76.80
312-3377	FA-30	Flashback Arrestor Set, Regulator Adaptor Style	FA-130P, FA-230P	83.80

FLASHBACK ARRESTORS INDIVIDUAL UNITS

Model No.	Mfg. No.	Description	Price/Each
312-3378	FA-100P	Flashback Arrestor, Oxygen, Torch Style	42.90
312-3380	FA-200P	Flashback Arrestor, Fuel Gas, Torch Style	42.90
312-3379	FA-130P	Flashback Arrestor, Oxygen, Regulator Adaptor Style	46.90
312-3381	FA-230P	Flashback Arrestor, Fuel Gas, Regulator Adaptor Style	46.90

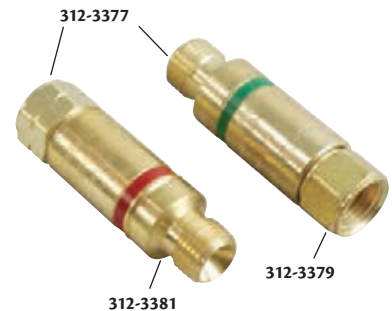

VALVED Y-CONNECTIONS, BRASS

PRESSURES TO 200 PSIG (1400 KPA)

- For use of two cutting and/or two welding torches at once
- Precision shut off valves
- B-Size (9/16"-18 Thread)



Model No.	Mfg. No.	Description	Service	Price/Each
312-1572	111	Oxygen RH: B-Size F Inlet to B-Size M Outlets	CGA-022	54.20
312-1584	112	Acetylene/F. Gases LH: B-Size F Inlet to B-Size M Outlets	CGA-023	54.20
312-1852	411	Inert Gas RH: 5/8"-18 M Inlet to 5/8"-18 F Outlets	CGA-032	68.30
312-1854	412	Water, Industrial Air LH: 5/8"-18 M Inlet to 5/8"-18 F Outlets	CGA-033	77.80



WELDING & METALWORKING

GAS CYLINDER CARTS

- Choice of carts for a wide range of cylinder sizes and terrains



Model No.	Base W" x D"	Wheel Type	Capacity	Weight lbs.	No. of Cylinders	Price /Each
ML413	25 x 13	16" Dia. pneumatic	244 cu.ft. oxygen, 300 cu.ft. acetylene cylinders	42	2	559.00
ML414	12 x 10	10" Dia. semi-pneumatic	300 cu.ft. 9" Dia. cylinder	40	1	269.00
ML415	25 x 13	14" Dia. x 3" rubber	244 cu.ft. oxygen, 300 cu.ft. acetylene cylinders	40	2	589.00
ML416	12 x 16	10" Dia. semi-pneumatic	144 cu.ft. or 244 cu.ft. oxygen, 130 cu.ft. acetylene cylinders	40	1	305.00
ML417	19 x 10	10" Dia. semi-pneumatic	144 cu.ft. or 244 cu.ft. oxygen, 130 cu.ft. acetylene cylinders	42	2	315.00

MINI-MIG WELDING CARTS

MM-8 Series Cylinder Cart

- Designed to carry a variety of Mini-MIG, Inverters, and Plasma machines
- Dimensions: 18" W x 36" D x 17" H
- Weight: 49 lbs.
- Cylinder capacity: 9 1/2"

Model No. ML419
Price/Each \$355.00



DUAL-CYLINDER DOLLIES

- Accommodates cylinders up to 12" in diameter, including a class 300 SCF industrial gas cylinder and a no. 5 acetylene cylinder
- Composite construction withstands extreme weather conditions
- Tough 16.5" diameter pneumatic wheels gives maneuverability on rough terrain
- 36" built-in tray holds tools, valves and torches
- Powder coat finish steel tool/supplies tray
- Handle offers maximum stability allowing for wrapping of hose equipment
- Rust, corrosion and spark resistant
- Will not dent, chip or scratch paint from cylinders
- Dimensions: 36.88" L x 23.5" W x 45" H
- Weight: 57 lbs.
- Load capacity: 500 lbs.

Model No. SAP856
Mfg. No. 7302-BK
Price/Each \$1515.00



PROFESSIONAL GAS CYLINDER TRUCKS

- Safety chain helps secure load
- 3 positions: 2 wheel, 4 wheel tilt and 4 wheel storage
- Easy conversion between all 3 modes using spring loaded position lock mechanism
- 8" mold-on rubber wheels, 3" swivel casters
- Holds cylinders up to 9 1/4" diameter
- Cart Material: Steel
- Ships knocked-down and boxed

MO344

MO345



Model No.	Mfg. No.	No. of Cylinders	Base Dimensions W" x L"	Overall Dimensions W" x D" x H"	Capacity lbs.	Price /Each
MO344	210123	1	9 x 7-1/4	19 x 17-1/2 x 41-3/4	250	610.00
MO345	210124	2	16-7/8 x 7-1/4	29 x 18-1/2 x 42-1/4	500	558.00

WELDING CYLINDER TORCH CARTS

- Designed for transporting cylinders and cutting torch
- Includes two tank compartments with heavy-duty ratchet straps
- Brackets are included for holding cutting torch and hose
- Convenient open-top storage tray included
- Includes lockable storage box for regulators
- Fork pockets included for easy transportation
- Not designed for use as a storage means for gas cylinders
- Cart Material: Steel



Model No.	Mfg. No.	Base Dimensions W" x L"	Overall Dimensions W" x D" x H"	Price /Each
TTV168	CYL-2	24 x 19-1/2	40-1/4 x 34-9/16 x 66-3/8	1525.00

GAS CYLINDER CABINETS

- Heavy-duty construction
- 2" x 2" 10-gauge formed steel angle posts
- 9-gauge wire mesh doors and walls for venting
- 14-gauge checker plate shelves and roof
- English and French warning labels included
- Padlock hasp for added security
- Innovative door design allows for left or right opening installation
- Easy assemble, knock-down feature saves on shipping costs

Note: Constructed to meet or exceed strict CSA International B149.2-0 Propane Storage and Handling Code. Cylinders must be stored vertically at all times.



SAF848



SAF837



SEB837



SEB838



SAF847

KLETON

LIQUID PROPANE (35-LB CYLINDERS)

COMPRESSED GAS (9" DIAMETER CYLINDERS)

Model No.	Dimensions			Cylinder Capacity	Wt. lbs.	Price /Each
	W"	x	D" x H"			
SAF837	44	x	30 x 74	10	210	1379.00
SAF848*	88	x	30 x 74	20	420	2283.00

*Consists of two units of the SAF837

Model No.	Dimensions			Cylinder Capacity	Wt. lbs.	Price /Each
	W"	x	D" x H"			
SEB837*	30	x	17 x 37	2	70	639.00
SEB838*	17	x	17 x 69	2	85	769.00
SAF836	44	x	30 x 37	6	135	1155.00
SAF847	44	x	30 x 74	12	270	1436.00

*All-welded, fully assembled

WELDING HOSE REEL

- Heavy-duty, reinforced steel stampings for increased strength
- Compact design allows reels to fit in tight locations
- Multi-position guide arms for multiple mounting options
- Kinkless, oil resistant high quality hose
- Spring rewind features long life spring with declutching arbor
- Durable, corrosion-resistant powder coat paint
- 1/4" oxygen and acetylene twin hose
- Leakproof double O-ring seals
- Grade R hose

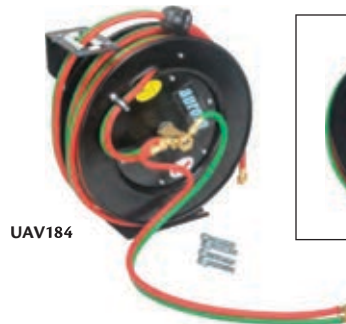

UAV184



AURORA
TOOLS

Model No.	Inner Hose Diameter"	Hose Length'	Working Pressure	Hose End	Dimensions			Reel Outlet	Inlet	Price /Each
					W"	x	D" x H"			
UAV183	1/4	25	300 PSI	9/16" NPTF	17-1/3	x	15 x 8-1/3	1/4" NPT	9/16" NPTF	250.00
UAV184	1/4	50	300 PSI	9/16" NPTF	18-7/10	x	17-1/2 x 8-1/2	1/4" NPT	9/16" NPTF	275.00

HOSE REEL

- Heavy-duty, reinforced steel stampings for increased strength
- For use with air and water
- Compact design allows reels to fit in tight locations
- Multi-position guide arms for multiple mounting options
- Kinkless, oil resistant high quality hose
- Spring rewind features long life spring with declutching arbor
- Durable, corrosion-resistant powder coat paint
- EPDM Rubber



UAV178



AURORA
TOOLS

Model No.	Inner Hose Diameter"	Hose Length'	Working Pressure	Hose End	Dimensions			Reel H"	Outlet	Inlet	Price /Each
					W"	x	D" x H"				
UAV178	1/4	35	300 PSI	3/8" NPT	17-1/3	x	15 x 8-1/3	1/4" NPT	3/8" NPT	185.00	
UAV182	1/2	50	300 PSI	1/2" NPT	21-7/10	x	18-1/2 x 9-2/3	1/2" NPT	1/2" NPT	305.00	



GAS CYLINDER POLY-STANDS

- Free-standing design maximizes floor space
- Made of polyethylene resisting sparking, rust and corrosion
- Prevents accidental tipping with durable nylon straps to keep cylinders and stand secure
- Ideal for inexpensive wall-mounted storage
- Accommodates two cylinders 3" to 12 3/8" diameter
- Dimensions: 28" W x 14" D x 30" H
- Handling capacity of 400 lbs.
- Weight: 14 lbs.
- Colour: Yellow
- OSHA 29 CFR.1910 approved

Model No. SE966
Mfg. No. 7212-YE
Price/Each \$429.00



GAS CYLINDER BRACKETS

- Brackets are constructed of epoxy powder coated 11-gauge hot rolled steel
- Edges are protected with steel reinforced vinyl guarding to maintain cylinders and provide extra grip
- Support straps are 54" L x 1.5" W polypropylene with steel cinch buckle; strength rated at 1200 PSI
- Wall mount brackets support 4" to 12" diameter cylinders

SB860

SB863

SB864



Model No.	Mfg. No.	Description	Dimensions			Wt. lbs.	Price /Each
			W"	D"	H"		
SB860	G-100	Single Cylinder Wall Bracket, Grey	8	x 2 1/4	x 4 1/4	3	62.00
SB863	G-200	Double Cylinder Wall Bracket, Grey	23 3/4	x 2 1/4	x 4 1/4	9	151.00
SB864	G-300	Triple Cylinder Wall Bracket,	35 3/4	x 2 1/4	x 4 1/4	11	183.00

6-PACK CYLINDER RACKS

- Maximizes floor space
- Will not rust or corrode
- Suited for outdoor storage
- Forkliftable, crane liftable or optional black caster frame for mobility to go anywhere
- Sturdy retaining straps assure stable storage
- Optional black accessory strap can be added to bottom for extra security
- Molded-in cap holders to keep cylinder caps at hand
- Cylinder rack has a loading capacity of 1200 lbs.
- Optional black rack ramp attaches for easy manoeuvring of cylinders
- Handling capacity of 1000 lbs.
- Handles 3" to 10" diameter cylinders
- OSHA 29 CFR.1910 approved

SE970

SE967



Model No.	Mfg. No.	Description	Dimensions			Wt. lbs.	Price /Each
			L"	W"	H"		
SE967	7202-YE	Cylinder Rack	48	x 31	x 41	62	1119.00
SE968	7204-BK	Caster Frame	33 1/2	x 31 1/2	x 41 1/2	50	525.00
SE969	7205-BK	Bottom Straps	-	-	-	1	44.90
SE970	7203-BK	Rack Ramp	46	x 20	x 6	21	339.00

UNIVERSAL MODULAR CYLINDER BRACKETS

- Design your own configuration
- Units link together to customize the amount of cylinders needed
- Attaches to any wall securely and easily
- Yellow polyethylene
- Accommodates 3" to 10" diameter cylinders
- Straps included
- Dimensions: 15.3" W x 3.3" D x 6.3" H
- Weight: 1 lbs.
- OSHA 29 CFR.1910 approved
- **Sold individually**
- Model No. SED115**
- Mfg. No. 7216-YE**
- Price/Each \$70.50**



HYDRAULIC LARGE LIQUID GAS CYLINDER CARTS

- Foot operated hydraulic pump
- Overall lift height 71.25" & 71" to top of lifting hook
- Overall lowered height 66.25" & 54" to top of lifting hook
- Rear total lock caster (swivel and turn) for secure loading and unloading
- 8" polyurethane tread, non marking crowned swivel casters with rolling and swivel lock
- 10" polyurethane tread wheels
- Cart Material: Steel
- Overall Dim.: 29-3/4" W x 44-3/4" D x 66-1/4" H

M0347



Model No.	Mfg. No.	Brake Option	Base Dimensions		Capacity lbs.	Price /Each
			W"	D"		
M0347	240250	Not Included	20	x 20	1000	4169.00
M0348	240251	Included	20	x 20	1000	4899.00

LARGE LIQUID GAS CYLINDER TRUCKS

- Easy transport of 20" large liquid gas cylinders
- Low profile design eases cylinder loading
- Provides great manoeuvrability in confined spaces
- 8" polyurethane tread, non-marking crowned swivel casters with rolling and swivel lock
- 10" polyurethane tread main wheels
- Heavy duty structural steel and schedule 40 pipe frame
- Quick connecting chain to secure load
- Cart Material: Steel
- Overall Dim.: 30" W x 31" D x 48-5/8" H



Model No.	Mfg. No.	Base Dimensions		Capacity lbs.	Price /Each
		W"	D"		
M0346	210131	20	x 20	1000	1979.00

OXYGEN/MAP-PRO™ GAS BRAZING/ WELDING/CUTTING TORCH KITS

- Uses oxygen and propane or propylene gas
- Includes:** Burner wand, Hose, Oxygen regulator, Fuel gas valve, Cylinder stand
- TTU687** 14.1-oz. MAP-Pro™ gas cylinder
- TTU688** 1.40-oz. oxygen cylinder
- Spark lighter
- 6 brazing/welding rods

Model No. NKD150
Price/Each \$209.00



TRIGGER START CAST ALUMINUM MAP-PRO™ GAS TORCH KITS

- Regulated for cold weather use
- Includes stainless steel burn tubes
- Compatible with both propylene and propane gases

Includes:
BV756 torch head
TTU687 14.1-oz. MAP-Pro™ gas cylinder

Model No. TTU692
Price/Each \$144.00



PENCIL FLAME TORCH KITS

- Solid brass construction
- General purpose utility flame
- Needle valve control and filtered orifice

Includes:
BV769 torch head
TTU686 14.1-oz. propane cylinder

Model No. TTU690
Price/Each \$52.39



2-PIECE SELF-IGNITING TORCH KITS

- For small, soft soldering jobs
- Adjustable flame control knob to be used with propane fuel

Includes:
TTV154 Self-igniting torch
TTU686 14.1-oz propane cylinder.

Model No. TTV153
Price/Each \$66.79



SPARK IGNITING MICRO TORCHES

- Precision light soldering, polyfoam cutting and heating
- Ideal for electronic repair
- Refillable, uses butane fuel
- Burns for 80 hours
- Includes electrical soldering tip

Model No. TTU299
Price/Each \$56.99



TRIGGER START TORCH KITS

- Comfortable, easy grip
- Self igniting quick-start trigger
- Uses propane gas
- Solid brass burn tip for easy repairs
- Pressure regulated to burn upside down

Includes:
TTV240 torch head
TTU686 14.1-oz propane cylinder

Model No. TTU691
Price/Each \$91.89



TRIGGER START SWIVEL HEAD TORCHES

Specially designed for convenience and accessibility.

- Solid brass regulator provides greater durability
- 360° swiveling torch head provides versatility and accessibility to tight and awkward work spaces
- Slim, one-handed trigger start eliminates the need for external ignition sources
- Double O-ring connection helps prevent gas leaks
- Uses propylene gas

Model No. WN963
Price/Each \$123.00



FUELS

14.1-OZ. PROPANE CYLINDER

Use with torches and most portable appliances requiring propane.

Model No. TTU686 Price/Each \$22.39

14.1-OZ. MAP-PRO™ GAS CYLINDER

Propylene gas burns hotter than propane. Use only with torches and appliances specifying "for use with propylene".

Model No. TTU687 Price/Each \$29.89

1.4-OZ. DISPOSABLE OXYGEN CYLINDER

Use with propylene gas for hottest brazing performance and light cutting/welding.

Model No. TTU688 Price/Each \$32.89



TTU686



TTU687



TTU688

WELDING & METALWORKING



Weller®

PROFESSIONAL SOLDERING GUNS

- Fingertip trigger to select high or low output
- Twin lights to illuminate work
- Tin-plated copper tip for high efficiency
- Ready to use in 6 seconds



KITS

TW149 and **TW151** includes: Carrying case, soldering gun, 1 soldering tip, and 1 coil of lead free solder

GUNS & KITS

Model No.	Mfg. No.	Description	Watts	Price /Each
TW148	D550	Professional Soldering Gun	260/200	118.50
TW149	D550PK	Professional Soldering Gun Kit	260/200	130.80
TW150	D650	Professional Soldering Gun	300/200	162.10
TW151	D650PK	Professional Soldering Gun Kit	300/200	170.30

REPLACEMENT SOLDERING GUN TIPS

Weller® tips are made of copper and are compatible with Weller® soldering guns. Available in cutting, smoothing and standard tips.



Cutting



Smoothing



Standard

Model No.	Mfg. No.	Description	Price /Each
TW153	6150	Cutting Tip Only	10.80
TW155	6160	Smoothing Tip Only	10.50
TW156	7250	Standard Tip Only, 2/Pkg.	10.80
TW157	7250N	Standard Tip w/Hex Nut	10.80

HIGH PERFORMANCE LED SOLDERING IRONS

- Three LED lights help illuminate the work area
- Round co-molded soft grip handle design for easy tip positioning
- Triangular handle area for maximum tip control
- Ceramic insulated stainless steel encased heater construction
- Excellent quality consumer iron 8 1/4" long
- Cord Length: 5'
- Tip and iron stand included
- cUL listed



Model No.	Mfg. No.	Description	Volts	Watts	Temp °F/°C	Standard Tip	Price /Each
TTV156	SP25NKC	Standard Duty - Kit	120	30	750/400	TW162, TW163, TW164	36.70

Weller®

TIPS

Replacement tips are nickel-plated copper or iron-plated copper for heavy-duty irons.



Model No.	Mfg. No.	Description	Tips	Use With Iron No.	Tip Size"	Price /Each
TW162	MT1	Cone Shaped Tip, 2/Pkg.	Nickel Plated	TTV155, TTV156	1/8	10.40
TW163	MT2	Screwdriver Tip, 2/Pkg.	Nickel Plated	TTV155, TTV156	1/8	12.90
TW644	ST7	Conical Tip	Iron, Nickel, Chromium Plated	TTV158	0.031	6.70

MINI BUTANE TORCH

- Industrial quality hand held torches for a variety of applications
- Meets Consumer Products Safety Commission child safety standards
- Every torch factory tested for performance and safety
- Specially designed to prevent liquid gas from entering nozzle, preventing flame outs and allowing use in any orientation
- Piezo ignition requires no batteries or flints
- Micro flame heats a very small, precise area
- Air adjustment ring and gas adjustment valve allow precise adjustment of flame
- Anodized aluminum barrel is tough and corrosion resistant
- Can be locked in on position for production work
- Includes stand for hands-free use
- Uses standard butane lighter fuel (not included)
- Flame Temperature: 2372° F (1300° C)
- Burn Time: 60 mins High, 90 mins Low
- Fuel Capacity: 22 ml
- Type: Micro Flame

Model No. UAV923

Mfg. No. 380021

Price/Each \$81.70



JET

PYROPEN®

- Ideal for service jobs in out of the way or confined space areas
- No batteries or electricity required
- Lightweight and easy to carry around
- Butane gas operated, will operate for up to three hours on one filling, and are ready to solder within 30 seconds
- Adjustable temperature controlled by varying gas flow
- Benefits for the outdoor servicing of electronics, radio and telecommunications
- Inactive hot air, ideal for shrink tubing, soldering and desoldering of SMD's

PYROPEN® SOLDERING KIT

- Metal carrying case complete with 3.3 mm soldering tip plus a 5.7 mm hot air tip, torch ejector, spanner, tool support clip, cleaning sponge and operating manual (fuel not included)
- Brazing torch feature offers more flexibility
- Interchangeable soldering tip and torch ejector

Model No. BW160
Mfg No. WSTA3
Price/Each \$280.60



SELF-IGNITING PYROPEN®

- Fitted with tapered needle tip plus hot air nozzle
- Protective plastic cap and operation manual (fuel not included)
- Instant push button self ignition ideal for single-handed operation

Model No. BW161
Mfg No. WPA2
Price/Each \$306.50



REPLACEMENT TIPS

Model No.	Mfg. No.	Description	Price /Each
BW165	WPT1	Taper Needle	28.80
BW166	WPT2	2.0 mm Chisel	32.90
BW169	WPT5	Taper Needle	32.90
BW172	WPT8	2.0 mm 35° Spade	32.90
BW175	WPT11	8.0 mm High Powered Chisel	49.90
BW177	WPT13	5.0 mm High Powered Long Taper Chisel	34.90

Weller®

PORTASOL® ECONOMICAL BUTANE SOLDERING IRONS

Weller®

- Self-igniting portable butane heat tool can solder, cut rope, and perform other open flame operations
- Allows anti-static soldering, ideal for electronics, avionics, cellular communications, alarm systems, marine and automotive
- Rugged stainless steel body
- Up to 125 W of power
- Fully adjustable up to 1076°F (580°C)
- Runs up to two hours on single refill
- Fuel level is clearly visible through a window on the body of the tool for quick filling
- Auto switch safety shut-off, iron plated tips
- Built-in filter reduces chance of problems caused by contaminated fuel
- **BW163** kit includes the iron, sponge, stand, and extra tips in a blow molded box



BW200

Model No.	Mfg. No.	Description	Price/Each
BW200	PSI100C	Portasol® Soldering Tool	162.10
BW163*	PSI100K	Portasol® Soldering Tool Kit	190.70

* Comes with **BW193** 2.4 mm double flat tip, **BW196** hot blower, **BW195** 4.8 mm double flat tip, **BW197** hot knife, cleaning sponge, storage case (fuel not included).

REPLACEMENT TIPS



BW188 BW189 BW190 BW192 BW193 BW194 BW195 BW196 BW197

Model No.	Mfg. No.	Description	Price /Each
BW188	PSI1	1.0 mm Single Flat	25.20
BW189	PSI2	2.4 mm Single Flat	25.20
BW190	PSI3	3.2 mm Single Flat	25.20
BW192	PSI5	1.0 mm Double Flat	25.20
BW193	PSI6	2.4 mm Double Flat	25.20
BW194	PSI7	3.2 mm Double Flat	25.20
BW195	PSI8	4.8 mm Double Flat	25.20
BW196	PSI9	Hot Blower Tip	22.10
BW197	PSI10	Hot Knife Tip	25.20

Note: Temperature range for tips is up to 850°F (450°C).

MATRIX®
INDUSTRIAL PRODUCTS

Maintain the ideal temperature in your workplace



ELECTRODE HOLDERS

- Grip the electrode closer to the end
- Allows you to use 20% more of the electrode than with standard tong holders
- Manufactured from copper alloy for maximum conductivity and strength
- Fibreglass insulators are designed to withstand intense heat and impact
- Will not burn, break or carbon char
- Electrode Capacity: 3/32" (2 mm) - 3/16" (5 mm)



Model No.	Amps	Description	Price /Each
NT629	400	Electrode Holder w/Neck Ring	20.95
NT631	600	Electrode Holder w/Neck Ring	26.85
NT630	400	Slimline – Bernard® Style Holder	20.95
NT818	-	Replacement Head for 400 Amps Electrode Holder	18.85
TTV098	-	Replacement Head for 600 Amps Electrode Holder	24.15



BERNARD® SHORTSTUB™ ELECTRODE HOLDERS

- Electrode can be used to within one inch of Shortstub™ head
- Built to last with a proven high impact, high heat separate head
- 2000-lb. gripping pressure
- Better visibility, greater hand-to-arc distance



Model No.	Mfg. No.	Amps	Electrode Capacity"	Price /Each
360-9001	405	400	1/16 - 1/4	117.00



CAM ACTION CABLE CONNECTORS

- One model fits cable sizes 4 through 4/0
- Manufactured from heavy wall precision machined brass alloy
- Cable is held securely by large dome screw
- Brass body assembly slides easily into unique heavy-duty neoprene insulator with no external screws to avoid shock hazards
- Cam locking connectors are compatible with most common brands



Model No.	Description	Price /Each
NT664	Male/Female Connector Set	20.50
NT649	Male Half with Insulator	12.35
NT650	Female Half with Insulator	9.85



EITHER-END CABLE CONNECTORS

- For use with 1/0 - 2/0 cable
- Unique "Either-End" design allows ends to interlock without the need for male/female connection points
- Brass body assembly slides into heavy-duty neoprene insulator



Model No.	Mfg. No.	Description	Price /Each
NP528	E-102M	Either-End Connector Set	105.00



HAMMER-ON LUGS

- Manufactured from heavy wall cast copper alloy, annealed for maximum conductivity
- Fast, easy installation, just slide into cable and strike it with hammer for durable connection



Model No.	For AWG Cable Sizes	Price /Each
NT606	1 - 4	14.90
NT605	1/0 - 2/0	18.50
NT604	3/0 - 4/0	26.90

DUAL POWER PLUGS

- Tough thermoplastic shell for long life
- Each dual combination plug is supplied with 30A blades and a flat 50A blade
- Built-in rejection feature prevents closure if blades are incorrectly positioned
- Shell and bottom are hinged in front for ease of assembly
- Solid brass blades with colour-coded terminals help to simplify wiring
- Nema Configuration: 6-30P/6-50P
- AC Voltage: 250 V
- Cord Diameter: 0.63" - 1.05"



Model No.	Mfg. No.	Description	Price /Each
XH645	931	Plug	24.90

SOLDER/CRIMP LUGS

- Manufactured from heavy wall copper alloy, annealed for maximum conductivity
- Long length and flared ends make installation fast and easy



Model No.	For AWG Cable Sizes	Price /Each
PB131	3/0 - 4/0	14.90

GROUND CLAMPS

- Manufactured from nickel-plated steel with forged brass conductors
- Heavy-duty springs provide positive strength at jaws
- **NT661** is ideal for farm welder and light shop work; current flows directly from lower jaw to welding cable
- **AUW394** is ideal for portable gas drive welders; braided zinc coated copper strap carries current to both upper and lower jaws, fully insulated hinge and spring prevents arcing



Model No.	Amps	Price /Each
NT661	300	6.99
AUW394	500	12.20

HEAVY-DUTY C-STYLE GROUND CLAMPS

- C-type jaws are adjusted by screw lever
- Rubber insulated cable connector



Model No.	Amps	Price /Each
NT665	600	57.25

MAGNETIC HOLDERS

- Multi-purpose holders for assembly and positioning
- Adheres to any metal object
- Ideal for welding, soldering, assembly and pipe installation



Model No.	Description	Strength lbs.	Dimensions"	Price /Each
NT626	Medium	15	5 x 3 1/4 x 1/2	4.45
NT627	Large	25	6 1/4 x 4 x 3/4	7.40
NT628	X-Large	40	8 x 5 x 1	11.20

MAGNETIC WELDING SQUARES

- Provides fast set-up and accurate holding of steel sheet stock, plate and tubing for welding
- Holds work pieces at 45°, 90°, 135° and 180° angles
- **TYG629**, **TYO502** and **TYG630** models feature "Breakaway Handle"



Model No.	Description	Pull lbs.	Dimensions L" x W" x H"	Price /Each
TYG624	Multi-Angle	55	4 3/8 x 3/4 x 3	20.20
TYG625	Compact	60	3 3/4 x 3/4 x 3 3/4	16.10
TYO501	Compact Multi-Angle	60	3 3/4 x 3/4 x 3 3/4	26.60
TLV266	Inside 90°, Outside 45/90°	40	5 1/2 x 5/8 x 2 7/8	32.30
TYG626	Adjustable	120	7 5/8 x 1 3/8 x 3 3/4	34.90
TYG627	Mid-Size	75	3 3/4 x 3/4 x 4 3/8	33.70
TYG628	Mid-Size, Covered*	75	3 3/4 x 3/4 x 4 3/8	41.90
TYG629	Mid-Size, Extra Power Covered HD	150	3 3/4 x 1 1/2 x 4 3/8	74.00
TYO502	Large Covered	160	8 x 3/4 x 8	102.00
TYG630	Large, Extra Power Covered*	325	8 x 1 1/2 x 8	179.00

* Weld spatter resistant cover

HEAVY-DUTY GROUND CLAMPS

- Manufactured from heavy-duty nickel-plated steel with forged brass conductors and braided copper strap to carry current to upper jaw
- Heavy-duty spring provides positive contact at jaws
- Cable is easy to install with built-in cable connector and oval point screw
- Allen-type wrench included



Model No.	Amps	Price /Each
NT668	300	19.45
NT669	500	22.90

MAGNETIC WELDING GROUNDS

- Powerful magnet attaches securely to your steel work surface
- Spring loaded 1/2" diameter stud assures constant electrical ground contact



Model No.	Holding Capacity lbs.	Stud Type Amperage	Diameter"	Height"	Price /Each
TYG631	35	250 A/Brass	3 1/2	2 1/4	54.20
TYG632	35	800 A/Copper	3 1/2	2 1/4	67.20

MAG90™ ON/OFF MAGNETIC SQUARES

- Locking On/Off handle for safety and ease of use
- Simple, fast work holding on multiple sides
- Eliminate the need for tedious clamping
- Can be used on flat or round steel
- Pre-tapped holes on all sides for mounting



TYO503

Model No.	Pull lbs.	Dimensions L" x W" x H"	Tap	Tap Depth"	Wt. lbs.	Price /Each
TYO503	150	1 1/2 x 1 1/2 x 2 3/4	#8-32	0.330	0.8	119.00
TYO504	450	3 x 2 1/2 x 4 5/8	1/4-20	0.500	4.3	324.00
TYO505	1000	4 1/4 x 4 x 4 3/4	3/8-16	0.625	10.5	631.00



WELDING & METALWORKING

AIR CARBON ARC GOUGING TORCHES

For gouging, cutting, beveling, piercing and flushing metal.

- Economical air carbon arc cutting process
- Can be used on most metals
- Chemical changes are virtually nil, as the process is primarily physical

AIR REQUIREMENTS

Ordinary compressed air as supplied by a shop airline or compressor is suitable. Most applications require 80-100 PSI.

Air

PSI:	80
kg/cm ² :	5.6
CFM:	35
CMM:	0.076

Compressor

Intermittent:	5 HP (3.73 KW)
Continuous:	7.5 HP (5.60 KW)



Model No.	Amps	Price /Each
NT667	800	199.00

PYTHONRAP™ CABLE COVERS

- Nylon cover
- Full length zipper
- 22' L x 4" W

Model No. NT887
Price/Each \$43.95



CABLE PROTECTORS

- Durable leather with Kevlar® sewn seams
- Lightweight to enhance flexibility and strength
- Metal snaps every 3"
- For TIG, MIG, plasma and flux-cored torch cable/hose assembly
- 22' L x 4" W

Model No. NP520
Price/Each \$70.30



AIR CARBON ARC GOUGING ELECTRODES

- Consistent copper coating DCCC
- Used for gouging out defective welds and cutting non-ferrous metals
- Electrodes are 12" in length
- Sold per package



Model No.	Dia."	Qty /Pkg.	Price /Each
NT632	5/32	100	32.30
NT633	3/16	50	20.00
NT634	1/4	50	29.75
NT635	5/16	50	30.60
NT636	3/8	50	44.65
NT637	1/2	50	83.10

ROD HOLDERS

- Double leather bottom and metal swivel clip
- 5-ply Kevlar® stitched with rivet reinforcement

Model No. NP519
Price/Each 10.45



INDUSTRIAL-DUTY SCRATCH BRUSHES

- Wood handle
- Choice of carbon or stainless steel bristles



Long Handle



Shoe Handle



"Toothbrush"



Model No.	Brush Length"	O.A. Length"	Wire Bristles	Rows	Trim Length"	Price /Each
LONG HANDLE BRUSHES						
NT607	5 3/4	13 3/4	Carbon Steel	3 x 19	1	3.60
NT608	5 3/4	13 3/4	Carbon Steel	4 x 19	1	4.25
NT611	5 3/4	13 3/4	Stainless Steel	3 x 19	1	5.50
NT612	6	10 1/4	Stainless Steel	4 x 19	1	5.95
SHOE HANDLE BRUSHES						
NT609	5 1/4	10 1/2	Carbon Steel	3 x 16	1	3.20
NT610	5 1/4	10 1/2	Carbon Steel	4 x 16	1	3.50
NT613	5	10 1/2	Stainless Steel	3 x 16	1	5.95
NT614	5	10 1/4	Stainless Steel	4 x 16	1	6.40
"TOOTHBRUSH" CLEANING BRUSH						
NT615	1 1/2"	7 3/4	Stainless Steel	3 x 7	1/2	1.60

CHIPPING HAMMERS

- Cone and chisel head
- Spring steel handle
- Head Length: 6 1/4"
- Overall Length: 10 1/2"

Model No. NP532
Price/Each \$7.25



MULTI-PURPOSE MIG PLIERS

- Eight-way pliers
- Nickel plated finish
- Ideally suited for removal of hot spatter from nozzle ends, as well as many other uses



NP537



Model No.	Description	Price /Each
TYX128	Premium Pliers	20.95
NP537	Pliers	13.60
NT666	Holster for Pliers	5.15

MATADOR® WELDER'S PLIERS

- Ideal for installing tips, nozzles and bushings, cutting and hammering
- Universal use for all wire feed guns
- Vanadium-steel construction is tough, durable
- Satin finish reduces rust

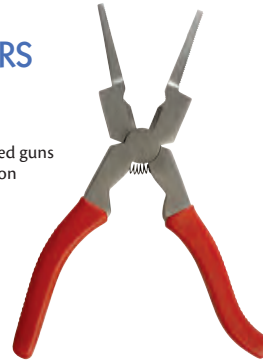

Model No.	Mfg. No.	Price /Each
899-1700	4705008	50.50

MIG NOZZLE REAMERS

- Cleans hot MIG nozzle on the torch
- Self adjusting to fit all size nozzles
- Expanding spring steel cleaner

Model No. TTU660
Price/Each \$6.30



AIR FLUX CHIPPERS

- Lightweight and compact design permits increased operator efficiency
- Paddle style trigger offers better speed control and precision
- Low noise, low vibration
- Durable
- Comes with 35 mm flat chisel
- Overall length: 10 1/4"
- Weight: 4.1 lbs.

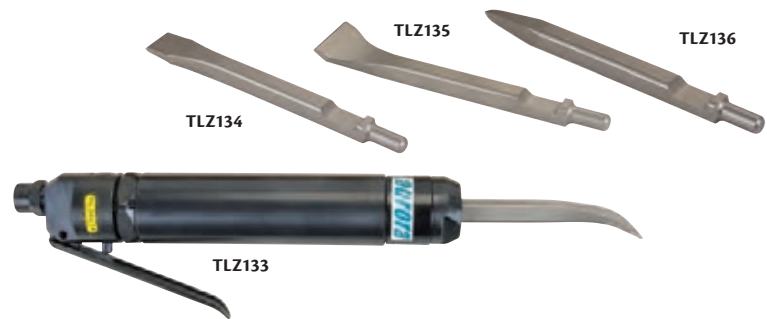

Model No.	Stroke in mm	Blows per minute BPM	Average Air Consumption CFM	Air Inlet	Hose Size in mm	Vibrations Less Than m/s ²	Sound Pressure Level dB(A)	Price /Each
TLZ133	1 1/2 38	4400	9	1/4" - 18 NPT	3/8 9.5	10.2	92	215.00

ACCESSORIES

Model No.	Description	Price/Each
TLZ134	20 mm Flat Chisel	31.45
TLZ135	35 mm Flat Chisel	31.45
TLZ136	Moil Pointed Chisel	31.45

SAFETUBE® ROD CANISTERS

- Protects electrodes from dirt, grease and moisture
- Pressure fitted O-ring provides a watertight seal
- Withstands electrodes heated to 250°F
- Requires only a quarter turn to remove cap
- Square sides prevent rolling
- Safety yellow colour increases visibility

14" CANISTER

- Holds up to 10 lbs. (5 kg) of 14" electrodes

18" CANISTER

- Holds up to 15 lbs. (7.5 kg) of 18" electrodes

40" CANISTER

- Holds up to 15 lbs. (7.5 kg) of 36" TIG/brazing rods

CARRY STRAP

- Provides easy transport for electrode canisters
- For use with 14" and 18" Safetubes®

WALL STORAGE RACK

- Provides storage for four 40" Safetube® TIG rod canisters



Model No.	Mfg. No.	Description	Capacity	Price /Each
ELECTRODE CANISTERS				
382-4010	1205441	Canister	Up to 10 lbs. of 14" Electrodes	21.50
382-4040	1205455	Canister	Up to 15 lbs. of 18" Electrodes	30.50
382-4020	1205451	Adjustable Carry Strap	-	18.90
TIG ROD CANISTER				
TTV109	1205488	Canister	Up to 15 lbs. of 36" TIG Rods	29.50
TTV110	1205490	Wall Storage Rack	-	179.00



MIG GUNS

- Recommended for applications using solid and flux core wire
- Guns are complete with 15' cable length
- A complete selection of replacement parts for most brands of guns is available
- Contact us for pricing on guns with different amperage ratings or cable lengths



BERNARD® STYLE REPLACEMENT AIR-COOLED MIG GUNS

200 AMPS

Rating:

- 200 Amps CO₂ @ 100% duty cycle
- 150 Amps mixed gas @ 100% duty cycle
- Wire Capacity: 0.023" - 0.045"

300 AMPS

Rating:

- 300 Amps CO₂ @ 100% duty cycle
- 250 Amps mixed gas @ 100% duty cycle
- Wire Capacity: 0.030" - 0.062"

350 AMPS

Rating:

- 350 Amps CO₂ @ 100% duty cycle
- 250 Amps mixed gas @ 100% duty cycle
- Wire Capacity: 0.030" - 0.062"

400 AMPS

Rating:

- 400 Amps CO₂ @ 100% duty cycle
- 300 Amps mixed gas @ 100% duty cycle
- Wire Capacity: 0.035" - 5/64"



Model No.	Mfg. No.	Feeder Plug	Price /Each
200 AMPS			
379-4395	B2-4215A	Bernard DP	309.00
379-1101	B2-4215AM	Miller DP	285.00
379-4510	B2-4215AE	Euro DP	285.00
379-4201	B2-4215AL	Lincoln DP	309.00
TTT009	B2-4215AWM	Lincoln Wirematic	285.00
TTT010	B2-4215AT	Tweco DP	285.00
300 AMPS			
NT172	B2-4315A	Bernard DP	339.00
NT174	B2-4315AM	Miller DP	259.00
NT173	B2-4315AE	Euro DP	279.00
NT204	B2-4315AL	Lincoln DP	315.00
TTT011	B2-4315AWM	Lincoln WM 250	279.00
NT175	B2-4315AT	Tweco DP	279.00

Model No.	Mfg. No.	Feeder Plug	Price /Each
350 AMPS			
379-4570	B2-43515A	Bernard DP	295.00
379-1113	B2-43515AM	Miller DP	279.00
TTT012	B2-43515AE	Euro DP	279.00
379-4223	B2-43515AL	Lincoln DP	255.00
TTT013	B2-43515AWM	Lincoln Wirematic	255.00
379-4920	B2-43515AT	Tweco DP	255.00
400 AMPS			
TW978	B2-4415A	Bernard DP	359.00
TW983	B2-4415AM	Miller DP	315.00
TW979	B2-4415AE	Euro DP	315.00
TW981	B2-4415AL	Lincoln DP	315.00
TW984	B2-4415AT	Tweco DP	315.00



Contact Tip



Long Contact Tip



BERNARD® STYLE CONSUMABLES

Model No.	Mfg. No.	Description	Size"	200 Amps	300 Amps	350 Amps	400 Amps	Price /Each
NT183	B7497	Contact Tip	0.023	X	X	X		1.18
NT179	B7488	Contact Tip	0.030	X	X	X		1.18
NT180	B7489	Contact Tip	0.035	X	X	X	X	1.09
PB052	B7496	Contact Tip	0.040	X	X	X	X	1.18
NT181	B7490	Contact Tip	0.045	X	X	X	X	1.09
PB054	B7498	Contact Tip	0.052	X	X	X	X	1.16
NT182	B7491	Contact Tip	1/16	X	X	X	X	1.11
PB048	B7492	Contact Tip	5/64				X	1.18
PB050	B7494	Contact Tip	7/64				X	1.05
TW993	B1589	Contact Tip, Long	0.035	X	X	X	X	1.69
TW994	B1590	Contact Tip, Long	0.045	X	X	X	X	1.69
PB044	B1598	Contact Tip, Long	0.052	X	X	X	X	1.69
TW995	B1591	Contact Tip, Long	1/16	X	X	X	X	1.69
TW996	B1592	Contact Tip, Long	5/64				X	3.79
TW997	B1593	Contact Tip, Long	3/32				X	1.69
379-1124	B4281	Contact Tip, Tapered	0.035	X	X	X		2.29
TTT133	B4282	Contact Tip, Tapered	0.045	X	X	X		2.29
TTT134	B4283	Contact Tip, Tapered	0.052	X	X	X		2.29
TTT132	B4280	Contact Tip, Tapered	1/16	X	X	X		2.29

Note: All reference to genuine manufacturer's equipment numbers and/or trade names or trademarks are for identification and convenience only. The trademarks and trade names are the property of their respective owners.

Continued on next page

BERNARD® STYLE CONSUMABLES

Continued from previous page



Nozzles



Gas Diffusers



Trigger Assembly



Liner Assembly

Model No.	Mfg. No.	Description	Size"	200 Amps	300 Amps	350 Amps	400 Amps	Price /Each
PB063	B4491	Nozzle, Brass, Standard	3/4 I.D.			X	X	9.09
PB064	B4591	Nozzle, Brass	3/4 I.D.			X		9.99
NT177	B4391	Nozzle, Brass	5/8 I.D.	X	X			7.09
NT178	B4393	Nozzle, Copper	5/8 I.D.	X	X			7.89
BZ934	B4392	Nozzle, Brass, Standard	1/2 I.D.	X	X			20.90
379-4224	B4394	Nozzle, Copper	1/2 I.D.	X	X			8.49
PB060	B4592	Nozzle, Copper	9/16 I.D.			X		10.50
379-1125	B4295	Nozzle, Brass	11/32 I.D.	X	X		X	11.90
NT176	B4335	Head Assembly, Standard		X	X			7.29
PB057	B4435	Head Assembly, Standard				X	X	7.39
379-1231	B7126	O-Ring		X	X			0.88
379-1232	B7127	O-Ring				X	X	0.90
379-1140	B4323R	Silicone Cap, Standard		X	X			1.89
379-1186	B4423R	Silicone Cap, Standard				X	X	1.89
379-1223	B4786	Body Tube Assembly		X	X			24.50
TTT137	B4790	Body Tube Assembly				X	X	23.50
379-1222	B4780	Insulator Hex Nut		X	X	X	X	1.89
379-1225	B5662	Trigger Assembly		X	X	X		5.30
379-1178	B4422	Trigger Assembly					X	33.50
379-1127	B43015	Liner Assembly, 15'	0.023 - 0.030	X	X			11.90
379-1135	B43115	Liner Assembly, 15', Standard	0.035 - 0.045	X	X			10.90
379-1139	B43215	Liner Assembly, 15'	0.045 - 0.062	X	X			11.50
379-5840	B43115X	Liner Assembly, Teflon®, 15'	0.035 - 3/64	X	X	X		24.50
379-1170	B44115	Liner Assembly, 15'	0.035 - 0.045			X	X	11.50
379-1175	B44215	Liner Assembly, 15'	0.045 - 0.062			X	X	10.90
379-1188	B44315	Liner Assembly, 15'	5/64				X	13.50

MILLER® STYLE REPLACEMENT AIR-COOLED MIG GUNS

• Guns are complete with 15' cable length

250 AMPS

Rating:

- 250 Amps CO₂ @ 100% duty cycle
- 250 Amps mixed gas @ 60% duty cycle
- Wire Capacity: 0.030" – 0.045"



379-M169-715



379-1050



GUNS

Model No.	Mfg. No.	Amps	Feeder Plug	Price /Each
NT206	M169-598	250	Miller DP	405.00

CONSUMABLES

Model No.	Mfg. No.	Description	Size"	150 Amps	250 Amps	Price /Each
NT168	M087-299	Contact Tip	0.023	X	X	0.71
NT165	M000-067	Contact Tip	0.030	X	X	0.70
NT166	M000-068	Contact Tip	0.035	X	X	0.70
NT167	M000-069	Contact Tip	0.045	X	X	0.70
379-M169-715	M169-715	Nozzle	1/2	X		6.79
NT169	M169-724	Nozzle, 1/8" Tip Recess	1/2		X	13.90
NT170	M169-725	Nozzle, 1/8" Tip Recess	5/8		X	13.90
379-1050	M169-726	Nozzle, Flush	5/8		X	14.50
TTT177	M169-727	Nozzle, 1/8" Tip Stickout	5/8		X	14.50
379-1055	M169-729	Nozzle Retainer			X	7.89
TTT178	M170-467	Replacement Retaining Ring		X		4.19
TTT179	M170-468	Replacement O-Ring			X	0.69
TTT180	M169-716	Retaining Head		X		5.89
TTT181	M170-470	Replacement Retaining Ring		X		5.09
TTT183	M169-717	Shock Washer		X		5.49
TTT184	M169-730	Shock Washer			X	4.89
TTT185	M169-718	Gooseneck, 45°		X		44.90
TTT186	M169-731	Gooseneck, 45°			X	74.90
NT171	M169-728	Gas Diffuser			X	2.39
TTT188	M194-010	Liner Conduit, 15'	0.023 - 0.025	X	X	11.50
TTT189	M194-011	Liner Conduit, 15'	0.030 - 0.035	X	X	11.50
TTT190	M194-012	Liner Conduit, 15'	0.035 - 0.045	X	X	11.50
TTT191	M194-014	Liner Conduit, 15', Aluminum	0.035 - 3/64		X	45.50

Note: All reference to genuine manufacturer's equipment numbers and/or trade names or trademarks are for identification and convenience only. The trademarks and trade names are the property of their respective owners.

WELDING & METALWORKING

CENTERFIRE™ SERIES NOZZLES, TIPS & DIFFUSERS

- No tools required to replace tip or nozzle
- "Drop-In" tip with no threads means quick change after burnback, reducing down time
- Large diameter tip base and tapered seat provide better electrical conductivity and heat transfer
- Spatter shield within nozzle protects diffuser and gives smoother, less turbulent gas flow
- Solid, concentric relationship between tip and nozzle keeps tip centered even after hard use... and abuse
- Threaded nozzle holds tip fixed at 1/8" or 1/4" recess, flush, or 1/8" stick out
- Compatible with all standard air-cooled Bernard® guns
- Complete family of tips and nozzles is available to meet most of your welding needs

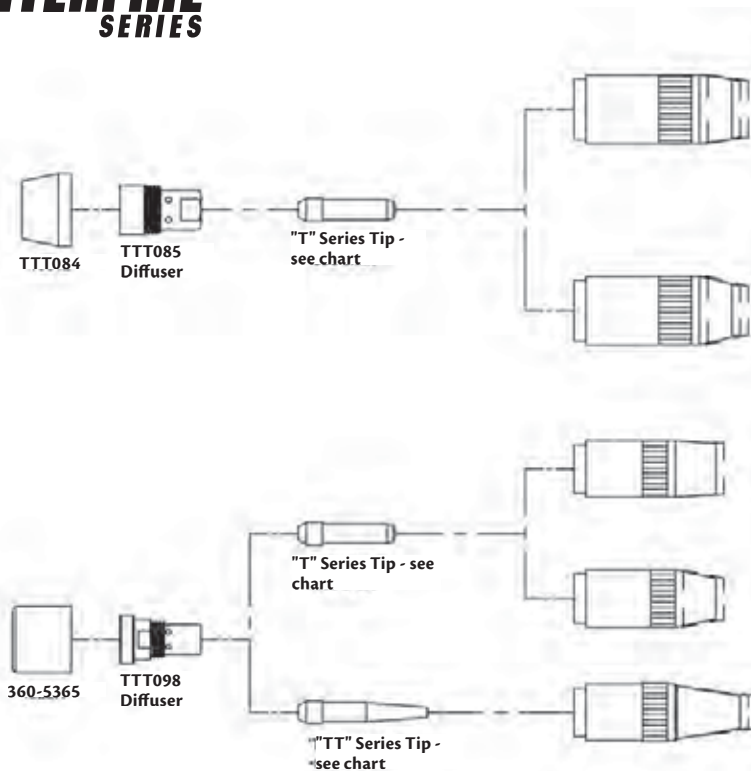

- TTU273** **Copper Nozzle**
(3/4" I.D., Flush Tip)
- TTU037** **Copper Nozzle**
(3/4" I.D., 1/8" Tip Recess)
- TTT092** **Copper Nozzle**
(3/4" I.D., 1/4" Tip Recess)
- TTT093** **Brass Nozzle**
(3/4" I.D., 1/8" Tip Recess)
- TTT094** **Brass Nozzle**
(3/4" I.D., 1/4" Tip Recess)

- TTU274** **Copper Nozzle**
(5/8" I.D., Flush Tip)
- TTU038** **Copper Nozzle**
(5/8" I.D., 1/8" Tip Recess)
- TTT095** **Copper Nozzle**
(5/8" I.D., 1/4" Tip Recess)
- TTT096** **Brass Nozzle**
(5/8" I.D., 1/8" Tip Recess)

- TTT097** **Brass Nozzle**
(5/8" I.D., 1/4" Tip Recess)
- TTT104** **Brass Nozzle**
(5/8" I.D., 1/8" Tip Recess)

- TTT106** **Brass Nozzle**
(1/2" I.D., Flush Tip)
- TTT105** **Brass Nozzle**
(1/2" I.D., 1/8" Tip Recess)

- TTU275** **Brass Nozzle**
(3/8" I.D., Flush Tip)
- TTT107** **Brass Nozzle**
(3/8" I.D., 1/8" Tip Recess)
- TTU276** **Brass Nozzle**
(3/8" I.D., 1/8" Tip Extension)

T SERIES		"T" Series Tip 		
Model No.	Mfg. No.	Description	Wire Size"	Price /Each
DIFFUSERS				
TTT084	10012	Insulator Cap	-	15.90
TTT085	D-1	Diffuser	-	24.90
CONTACT TIPS				
TTT086	T-030	1.50" Long	0.030	3.19
TTT087	T-035	1.50" Long	0.035	3.19
TTT088	T-039	1.50" Long	0.039	3.19
TTT089	T-045	1.50" Long	0.045	3.19
TTT090	T-052	1.50" Long	0.052	3.19
TTT091	T-062	1.50" Long	1/16	3.19
NOZZLES				
TTU273	N-3400C	Copper, Flush Tip	3/4 I.D.	32.90
TTU037	N-3418C	Copper, 1/8" Tip Recess	3/4 I.D.	32.90
TTT092	N-3414C	Copper, 1/4" Tip Recess	3/4 I.D.	32.90
TTT093	N-3418B	Brass, 1/8" Tip Recess	3/4 I.D.	31.90
TTT094	N-3414B	Brass, 1/4" Tip Recess	3/4 I.D.	31.90
TTU274	N-5800C	Copper, Flush Tip	5/8 I.D.	32.90
TTU038	N-5818C	Copper, 1/8" Tip Recess	5/8 I.D.	32.90
TTT095	N-5814C	Copper, 1/4" Tip Recess	5/8 I.D.	32.90
TTT096	N-5818B	Brass, 1/8" Tip Recess	5/8 I.D.	31.90
TTT097	N-5814B	Brass, 1/4" Tip Recess	5/8 I.D.	31.90

TT SERIES		"TT" Series Tip 		
Model No.	Mfg. No.	Description	Wire Size"	Price /Each
DIFFUSERS				
360-5365	4323R	Insulator Cap	-	15.90
TTT098	DS-1	Diffuser	-	24.90
CONTACT TIPS				
TTT099	TT-030	2.00" Long	0.030	5.39
TTT100	TT-035	2.00" Long	0.035	5.19
TTT101	TT-045	2.00" Long	0.045	5.19
TTT102	TT-052	2.00" Long	0.052	5.19
TTT103	TT-062	2.00" Long	1/16	5.19
NOZZLES				
TTT104	NS-5818B	Brass, 1/8" Tip Recess	5/8 I.D.	25.90
TTT106	NS-1200B	Brass, Flush Tip	1/2 I.D.	25.90
TTT105	NS-1218B	Brass, 1/8" Tip Recess	1/2 I.D.	25.90
TTU275	NST-3800B	Brass, Flush Tip	3/8 I.D.	29.50
TTT107	NST-3818B	Brass, 1/8" Tip Recess	3/8 I.D.	29.50
TTU276	NST-38XTB	Brass, 1/8" Tip Extension	3/8 I.D.	29.50

FLEX-LOC™ TORCHES

- Flex-Loc™ series torch is a variable angle torch that locks into position within a 360° rotation
- Interchangeable heads allow different size tungsten and head sizes to be quickly and efficiently changed
- Ergonomically designed to help eliminate fatigue
- Great for applications requiring a unique angle yet allowing the user a rigid torch

Applications: Cup walking on pipe root welds, welds that require a mirror to access weldment, welds requiring different tungsten sizes.

Torch packages include: Body assembly, replaceable torch head (with heat shield and back cap) and cable assembly

AIR (GAS) COOLED TORCHES

- Gas-cooled models are available with or without gas control valve and have a Hi-Flex one-piece concentric cable assembly
- Length: 7 3/4" without valve; 8 1/2" with valve

WATER COOLED TORCHES

- Water cooled models are equipped with a Tri-Flex cable assembly
- Length: 7 3/4" without valve

821-1750



820-1905

821-1760



820-1920



Model No.	Mfg. No.	Cable Size'	Amps	Cable	Head Style	Price /Each
AIR-COOLED TORCHES WITHOUT VALVE						
820-1905	FL1312	12 1/2	130	1-Piece	FL2L	365.00
TTT376	FL1325	25	130	1-Piece	FL2L	429.00
820-1920	FL1512	12 1/2	150	1-Piece	FL3L	365.00
820-1930	FL1525	25	150	1-Piece	FL3L	425.00
WITH VALVE						
TTT379	FL1312V	12 1/2	130	1-Piece	FL2L	439.00
820-1915	FL1325V	25	130	1-Piece	FL2L	489.00
820-1925	FL1512V	12 1/2	150	1-Piece	FL3L	439.00
820-1935	FL1525V	25	150	1-Piece	FL3L	489.00
WATER-COOLED TORCHES WITHOUT VALVE						
820-1940	FL2312	12 1/2	230	Tri-Flex	FL2L	415.00
820-1945	FL2325	25	230	Tri-Flex	FL2L	449.00
820-2075	FL2512	12 1/2	250	Tri-Flex	FL3L	415.00
820-1950	FL2525	25	250	Tri-Flex	FL3L	449.00

TORCH HEAD SELECTOR CHART

Model No.	Mfg. No.	Amps		Head Style	Price /Each
		Gas-Cooled	Water-Cooled		
821-1750	FL2L	130	230	2 Series	109.00
821-1760	FL3L	150	250	3 Series	109.00

FLEX TORCHES

WATER-COOLED

- Modular design for easy low-cost repairs
- Tough copper head and coil assembly – runs cooler, lasts longer
- "Bellows" type boot for maximum flexibility
- Built-in restraining wire – resist leaking from coil and boot
- Built-in ball/stem gas control valve for greater control
- Ribbed handle for cool operation
- Heavy-duty, two-piece power cable for uninterrupted use
- Long neck option, **366-4735**, for extended reach requirements
- Maximum amperage is determined by torch assembly and head
- Vinyl for heavy duty use and reinforced neoprene hose for increased durability and flexibility
- Torch assembly includes: **366-1315** and **366-2998** heads, power cable, water hose, gas hose, and handle

TORCH PACKAGE ASSEMBLY

Model No.	Mfg. No.	Power Cable'	Power Cable	Water Hose	Gas Hose	Price /Each
366-7040	WP-225-12	12	45V03	45V07	45V09	665.00
TTT283	WP-225-25	25	45V04	45V08	45V10	685.00
TTT286	WP-225-12-R	12, Neoprene	45V03R	45V07R	45V09R	809.00
366-7200	WP-225-25-R	25, Neoprene	45V04R	45V08R	45V10R	885.00

TORCH PACKAGE ASSEMBLY

Model No.	Mfg. No.	Power Cable'	Power Cable	Water Hose	Gas Hose	Price /Each
TTT287	WP-25-12	12	45V03	45V07	45V09	569.00
366-4741	WP-25-25	25	45V04	45V08	45V10	689.00
TTT290	WP-25-12-R	12, Neoprene	45V03R	45V07R	45V09R	775.00

FLEXIBLE TORCH BODY

Model No.	Mfg. No.	Max. Amps	Price /Each
FOR USE WITH INTERCHANGEABLE HEADS			
366-7000	WP-225	225	415.00

LONG REACH FLEX-PENCIL TYPE TORCH BODY

Model No.	Mfg. No.	Max. Amps	Price /Each
366-4735	WP-25	200	359.00

INTERCHANGEABLE HEADS



Model No.	Mfg. No.	Max. Amps A/C*	Max. Amps W/C**	Head Angle°	Fits	Price /Each
366-1315	9-70	125	200	70	WP-9, WP-9V WP-20 WP-225	93.90
TTT292	9P	125	200	180	WP-9, WP-9V WP-20 WP-225	105.00
TTT293	24	80	160	70	WP-24, WP-24W WP-225	98.50
366-2998	1726	150/200	225	70	WP-17, WP-17V WP-18, WP-18V, WP-26, WP-26V WP-225	93.90
TTT294	1726P	150/200	225	180	WP-17, WP-17V WP-18, WP-18V, WP-26, WP-26V WP-225	125.00
TTT295	24-90	80	160	90	WP-24, WP-24W WP-225	119.00

* Air cooled

** Water cooled

WELDING & METALWORKING

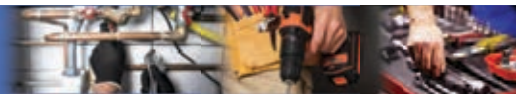

Innovative "WP" silicone rubber insulated TIG welding torches

AIR (GAS) COOLED TORCHES

WP-24

Small, Lightweight

- Ideal for intricate work
- Reaches into tight places
- Handle mounted gas control valve
- Feather weight, but well balanced and durable
- Torch body head: 60° angle
- Torch length: 7 1/2"
- Max capacity: 80 A
- Handle style: Ribbed



WP-9

Versatile, Lightweight for Thin Gauge Materials

- Quick-release tungsten adjustment
- Torch body head: 70° angle
- Torch length: 7"
- Max capacity: 125 A
- Handle style: Ribbed

Description	Amps	Max. Angle	Gas Valve	Power Cable	Accessory Kit
WP-24 TORCH BODY					
W/insulating gasket	80	60°	No	-	AK-5
W/insulating gasket and flexible head	80	60°	No	-	AK-5
W/insulating gasket, gas valve and flexible head	80	60°	Slide	-	AK-5
WP-24 TORCH PACKAGES - TORCH BODY, HANDLE, 25' POWER CABLE					
W/insulating gasket	80	60°	No	1-Piece Rubber Jacketed	AK-5
W/insulating gasket and flexible head	80	60°	No	1-Piece Rubber Jacketed	AK-5
W/insulating gasket, gas valve and flexible head	80	60°	Slide	1-Piece Rubber Jacketed	AK-5
WP-9 TORCH BODY					
W/cup gasket	125	70°	No	-	AK-1
W/cup gasket and gas valve	125	70°	Knob & Stem	-	AK-1
W/cup gasket and flexible head	125	70°	No	-	AK-1
W/cup gasket, gas valve and flexible head	125	70°	Knob & Stem	-	AK-1
WP-9 TORCH PACKAGES - TORCH BODY, HANDLE, MEDIUM BACK CAP, 25' POWER CABLE					
W/cup gasket	125	70°	No	1-Piece Rubber Jacketed	AK-1
W/cup gasket and gas valve	125	70°	Knob & Stem	1-Piece Rubber Jacketed	AK-1
W/cup gasket and flexible head	125	70°	No	1-Piece Rubber Jacketed	AK-1
W/cup gasket, gas valve and flexible head	125	70°	Knob & Stem	1-Piece Rubber Jacketed	AK-1
WP-17 TORCH BODY					
W/cup gasket	150	70°	No	-	AK-2
W/cup gasket and gas valve	150	70°	Knob & Stem	-	AK-2
W/cup gasket and flexible head	150	70°	No	-	AK-2
W/cup gasket, gas valve and flexible head	150	70°	Knob & Stem	-	AK-2
WP-17 TORCH PACKAGES - TORCH BODY, LONG BACK CAP, HANDLE, 25' POWER CABLE					
W/cup gasket	150	70°	No	2-Piece	AK-2
W/cup gasket and gas valve	150	70°	Knob & Stem	2-Piece	AK-2
W/cup gasket	150	70°	No	1-Piece Rubber Jacketed	AK-2
W/cup gasket and gas valve	150	70°	Knob & Stem	1-Piece Rubber Jacketed	AK-2
W/cup gasket and flexible head	150	70°	No	1-Piece Rubber Jacketed	AK-2
W/cup gasket, gas valve and flexible head	150	70°	Knob & Stem	1-Piece Rubber Jacketed	AK-2
WP-26 TORCH BODY					
W/cup gasket	200	70°	No	-	AK-3
W/cup gasket and gas valve	200	70°	Knob & Stem	-	AK-3
W/cup gasket and flexible head	200	70°	No	-	AK-3
W/cup gasket, gas valve and flexible head	200	70°	Knob & Stem	-	AK-3
WP-26 TORCH PACKAGES - TORCH BODY, LONG BACK CAP, HANDLE, 25' POWER CABLE					
W/cup gasket	200	70°	No	2-Piece	AK-3
W/cup gasket and gas valve	200	70°	Knob & Stem	2-Piece	AK-3
W/cup gasket	200	70°	No	1-Piece Rubber Jacketed	AK-3
W/cup gasket and gas valve	200	70°	Knob & Stem	1-Piece Rubber Jacketed	AK-3
W/cup gasket and flexible head	200	70°	No	1-Piece Rubber Jacketed	AK-3
W/cup gasket, gas valve and flexible head	200	70°	Knob & Stem	1-Piece Rubber Jacketed	AK-3

WP-17

High Capacity for Thin to Medium Gauge Materials

- Compact and durable for field welding applications
- Ribbed handle for comfort and cool operation
- Finger tip gas control valve on WP-17V
- Torch body head: 70° angle
- Torch length: 7 3/4"
- Max capacity: 150 A
- Handle style: Ribbed



WP-17

WP-26

Maximum Capacity for Continuous Heavy-Duty Use

- Heavy copper construction for rugged field work
- Torch body head: 70° angle
- Torch length: 8 1/2"
- Max capacity: 200 A
- Handle style: Ribbed



WP-26

WELDCRAFT



Model No.	Weldcraft Mfg. No.	Price /Each	Model No.	Weldmate Mfg. No.	Price /Each	Model No.	C-K Mfg. No.	Price /Each
366-4669	WP-24	189.00				820-1590	CK80	82.90
TTT271	WP-24F	289.00				820-1615	CK90	155.00
TTT272	WP-24FV	349.00				820-2070	CK90V	185.00
TTT273*	WP-24-25-R	515.00						
TTT275*	WP-24F-25-R	599.00	363-1945	VT-9F-25-R	265.00			
TTT276*	WP-24FV-25-R	669.00	363-1970	VT-9FV-25-R	265.00			
366-4249	WP-9	129.00				820-2205	CK130V	145.00
366-4378	WP-9V	205.00						
366-4278	WP-9F	229.00						
366-4300	WP-9FV	299.00						
366-4402*	WP-9-25-R	369.00				820-2270	CK1325H RG	229.00
366-4399*	WP-9V-25-R	429.00				820-2105	CK1325VH RG	279.00
TTT277*	WP-9F-25-R	475.00						
366-4324*	WP-9FV-25-R	545.00				820-2090	CK1325VH FX	325.00
366-4438	WP-17	135.00				820-1115	CK150 RG	74.50
366-4513	WP-17V	215.00				820-1125	CK150V RG	115.00
366-4462	WP-17F	245.00				820-1110	CK150 FX	135.00
366-4486	WP-17FV	309.00				820-1120	CK150V FX	165.00
NP473	WP-17-25-2	495.00						
NP474	WP-17V-25-2	555.00				820-1200	CK1525VN RG	265.00
366-4459*	WP-17-25-R	385.00				820-1165	CK1525H RG	215.00
366-4540*	WP-17V-25-R	455.00				820-1185	CK1525VH RG	265.00
366-4483*	WP-17F-25-R	495.00						
366-4510*	WP-17FV-25-R	559.00				820-1180	CK1525VH FX	315.00
366-4744	WP-26	155.00	363-1280	VT-26	80.90	820-1280	CK210-R / CK26 RG	96.90
366-4822	WP-26V	245.00	363-1640	VT-26V	125.00	820-1290	CK210V-R / CK26V RG	145.00
366-4774	WP-26F	295.00	363-2025	VT-26F	125.00	820-1275	CK210-F / CK26 FX	169.00
366-4795	WP-26FV	359.00	363-2050	VT-26FV	165.00	820-1285	CK210V-F / CK26V FX	209.00
NP476	WP-26V-25-2	685.00	363-1220	VT-26-25-2	345.00			
366-4765*	WP-26-25-R	505.00	363-1455	VT-26V-25-2	355.00	820-1355	CK2125H-R / CK26-25-R RG	479.00
366-4843*	WP-26V-25-R	585.00	363-1435	VT-26-25-R	479.00	820-1390	CK2125VH-R / CK26V-25-R RG	489.00
366-4792*	WP-26F-25-R	639.00	363-1460	VT-26V-25-R	489.00	820-1350	CK2125H-F / CK26-25-R FX	489.00
366-4819*	WP-26FV-25-R	705.00	363-2045	VT-26F-25-RFX	505.00	820-1380	CK2125VH-F / CK26-25-R FX	505.00
			363-2070	VT-26V-25-RFX	515.00			

* Power cable adapter must be ordered separately



Innovative "WP" silicone rubber insulated TIG welding torches

WATER COOLED

- Require cooling water flow of one quart per minute at a maximum of 50 PSI pressure

WP-24W

Small Torch

- Ideal for cramped locations
- Fits through narrow openings yet excellent capacity
- Extremely light and well balanced
- Water cooling requirements: 1 quart per minute at maximum of 50 PSI pressure
- Torch body head: 70° angle
- Torch length: 7 1/2"
- Max capacity: 180 amps
- Handle style: Textured

WP-20

Lightweight, Small Durable

- Compact and well-balanced for general duty use
- Efficient around-the-head cooling for trouble free performance and long life
- Water cooling requirements: 1 quart per minute at maximum of 50 PSI pressure
- Torch body head: 70° angle
- Torch length: 7"
- Max capacity: 250 amps
- Handle style: Textured



Description	Amps	Max. Angle	Gas Valve	Power Cable	Accessory Kit
WP-24W TORCH BODY					
W/insulating gasket	180	70°	No	-	-
WP-24W TORCH PACKAGES - TORCH BODY, HANDLE, 25' POWER CABLE & HOSES					
W/insulating gasket	180	70°	No	-	-
W/insulating gasket	180	70°	No	1-Piece Rubber Jacketed	-
WP-20 TORCH BODY					
W/cup gasket	250	70°	No	-	AK-4
W/cup gasket and gas valve	250	70°	Knob & Stem	-	AK-4
WP-20 TORCH PACKAGES - TORCH BODY, MEDIUM BACK CAP, HANDLE, 25' POWER CABLE & HOSES					
W/cup gasket	250	70°	No	3-Piece Vinyl	AK-4
W/cup gasket and gas valve	250	70°	Knob & Stem	3-Piece Vinyl	AK-4
W/cup gasket	250	70°	No	1-Piece Rubber Jacketed	AK-4
WP-18 TORCH BODY					
W/cup gasket	350	70°	No	-	AK-3
W/cup gasket and gas valve	350	70°	Knob & Stem	-	AK-3
WP-18 TORCH PACKAGES - TORCH BODY, LONG BACK CAP, 25' POWER CABLE & HOSES					
W/cup gasket	350	70°	No	3-Piece Vinyl	AK-3
W/cup gasket and gas valve	350	70°	Knob & Stem	3-Piece Vinyl	AK-3
W/cup gasket	350	70°	No	1-Piece Rubber Jacketed	AK-3
W/cup gasket and gas valve	350	70°	Knob & Stem	1-Piece Rubber Jacketed	AK-3

WP-18

Work Horse for Continuous Duty

- Heavy-duty rugged production torch for continuous duty to 350 amps
- Water cooling requirements: 1 quart per minute at maximum of 50 PSI pressure
- Built-in fingertip gas control valve available on WP-18V models
- Torch body head: 70° angle
- Torch length: 9 1/4"
- Max capacity: 350 amps
- Handle style: Textured



WP-18

WELDCRAFT®



Model No.	Weldcraft Mfg. No.	Price /Each	Model No.	Weldmate Mfg. No.	Price /Each	Model No.	C-K Mfg. No.	Price /Each
366-4726	WP-24W	249.00						
366-4732*	WP-24W-25	565.00						
TTT278*	WP-24W-25-R	745.00						
366-4597	WP-20	229.00				820-1260	CK200	115.00
TTT279	WP-20V	379.00				820-1265	CK200V	169.00
NP477	WP-20-25	539.00				820-1405	CK225	315.00
NP478	WP-20V-25	689.00				820-1420	CK225V	365.00
366-4610*	WP-20-25-R	729.00				818-1471	CK225SF	429.00
366-4543	WP-18	309.00	363-1285	VT-18	125.00	820-1505	CK300	135.00
366-4585	WP-18V	485.00				820-1510	CK300V	205.00
NP479	WP-18-25	599.00				820-1530	CK325	355.00
NP480	WP-18V-25	765.00				820-1545	CK325V	439.00
TTT281*	WP-18-25-R	835.00				TTU659	CK325VSF	555.00
TTT282*	WP-18V-25-R	985.00						

* Power cable adapter must be ordered separately



LAVA NOZZLES (CERAMIC)

- Made from grade "A" lava materials
- Less shock-and heat-resistant than alumina nozzles
- Functions in confined areas where excessive heat is reflected back into the nozzle
- Ideal for general applications
- Packed 10 nozzles per box

WELDCRAFT



Size	Orifice"	Fits Torch Series	Model No.	Weldcraft Mfg. No.	Price /Each	Model No.	C-K Mfg. No.	Price /Each
LAVA NOZZLES - 1 27/32" LENGTH								
4	1/4	WP-17, WP-17V,	NP431	105Z43	51.50	818-2185	3C4	43.50
5	5/16	WP-18, WP-18V,	366-2800	105Z42	35.50	818-2210	3C5	43.50
6	3/8	WP-26, WP-26V	366-2806	105Z44	50.50			
7	7/16		366-2809	105Z45	44.50	818-2240	3C7	43.50
8	1/2		366-1000	08N78	50.50			
10	5/8					818-2150	3C10	43.50
12	3/4					TTT001	3C12	43.50
LAVA NOZZLES - 1 5/32" LENGTH								
4	1/4	WP-9, WP-9V,	366-1609	13N14	35.50			
5	5/16	WP-20,	366-1612	13N15	36.50			
6	3/8	WP-25,	366-1615	13N16	41.50			
7	7/16		NP440	13N17	35.50			
8	1/2		NP441	13N18	36.90	818-1780	2C8	38.50
10	5/8		366-1624	13N19	29.50			
LAVA NOZZLES - 5/8" LENGTH								
4	1/4		366-2368	53N24	31.50			
5	5/16		366-2371	53N25	30.90			
6	3/8		366-2377	53N27	31.50	818-2805	8C6	27.59
LAVA NOZZLES - 1 1/8" LENGTH								
6L	3/8		366-2374	53N26	41.50			
LONG LAVA NOZZLES - 3 7/32" LENGTH								
4L	1/4	WP-17, WP-17V,	NP456	12N03	61.50	818-2205	3C4L	54.50
5L	5/16	WP-18, WP-18V,	NP457	105Z60	73.90	818-2225	3C5L	54.50
7L	7/16		NP459	105Z61	61.50			
LONG LAVA NOZZLES - 1 7/8" LENGTH								
3L	3/16	WP-9, WP-9V,	366-2941	796F70	54.50	818-1725	2C3L	49.50
4L	1/4	WP-20,	366-2926	796F71	63.90			
5L	5/16	WP-25	366-2929	796F72	90.90			
6L	3/8		366-2932	796F73	43.90			
LONG LAVA NOZZLES - 2 1/2" LENGTH								
3XL	3/16	WP-9, WP-9V,	TTT310	796F74	59.90			
4XL	1/4	WP-20, WP-25	366-2938	796F75	69.90			

Note: The nozzle indicates the orifice (I.D. of the outlet end) in 1/16ths of an inch. No. 4 = 1/4" I.D.



NP431



366-1000



818-1780



NP457



TOOLS THAT MEASURE UP!

AURORA
TOOLS

ALUMINA NOZZLES

- Made from high strength alumina materials
- Very good electrical insulating properties
- Exceptionally high impact resistance, heat resistance and thermal conductivity
- Recommended for most welding operations except for use in confined area
- Resists splatter build-up

WELDCRAFT



Size	Orifice"	Fits Torch Series	Model No.	Weldcraft Mfg. No.	Price /Each	Model No.	C-K Mfg. No.	Price /Each
ALUMINA NOZZLES – 1 27/32" LENGTH								
4	1/4	WP-17, WP-17V,	366-1504	10N50	6.59	818-2050	3A4	2.89
5	5/16	WP-18, WP-18V,	NP396	10N49	6.59	818-2060	3A5	2.89
6	3/8	WP-26, WP-26V	366-1492	10N48	5.99	818-2070	3A6	2.89
7	7/16		366-1486	10N47	6.59	818-2080	3A7	2.89
8	1/2		366-1483	10N46	6.69	818-2090	3A8	2.89
10	5/8		366-1480	10N45	6.59	818-2040	3A10	2.89
12	3/4		366-1477	10N44	6.89	818-2045	3A12	2.89
ALUMINA NOZZLES – 1 5/32" LENGTH								
4	1/4	WP-9, WP-9V,	366-1591	13N08	5.89	818-1615	2A4	2.89
5	5/16	WP-20,	366-1594	13N09	5.99	818-1625	2A5	2.89
6	3/8	WP-25	366-1597	13N10	5.79	818-1635	2A6	2.89
7	7/16		366-1600	13N11	5.89	818-1645	2A7	2.89
8	1/2		366-1603	13N12	5.89	818-1655	2A8	2.89
10	5/8		366-1606	13N13	5.99	818-1610	2A10	2.89
ALUMINA NOZZLES – 5/8" LENGTH								
4	1/4	WP-24, WP-24W	TTT300	A53N24	20.90			
5	5/16		TTT301	A53N25	20.90			
LONG ALUMINA NOZZLES – 3" LENGTH								
5L	5/16	WP-17, WP-17V,	NP445	10N49L	57.50	818-3625	3A5L	30.90
6L	3/8	WP-18, WP-18V,	NP446	10N48L	30.90	TTT004	3A6L	30.90
7L	7/16	WP-26, WP-26V	366-1489	10N47L	57.50	TTT005	3A7L	30.90
ALUMINA GAS LENS NOZZLES – 1 5/8" LENGTH (ALSO ORDER INSULATOR)								
4	1/4	WP-17, WP-17V,	366-2467	54N18	7.39	818-2115	3AG4	2.89
5	5/16	WP-18, WP-18V,	366-2461	54N17	7.19	818-2120	3AG5	2.89
6	3/8	WP-26, WP-26V	NP386	54N16	6.69	818-2125	3AG6	2.89
7	7/16		366-2449	54N15	6.69	818-2130	3AG7	2.89
8	1/2		366-2446	54N14	6.19	818-2135	3AG8	2.89
ALUMINA GAS LENS NOZZLES – 1 1/8" LENGTH (ALSO ORDER INSULATOR)								
Short	11/16	WP-17, WP-17V WP-18, WP-18V WP-26, WP-26V	TTT307	54N19	6.99	818-2105	3AG11	2.89
ALUMINA GAS LENS NOZZLES – 1" LENGTH (ALSO ORDER INSULATOR)								
4	1/4	WP-9, WP-9V,	366-2392	53N58	6.59	818-1665	2AG4	2.89
5	5/16	WP-20,	NP390	53N59	6.39	818-1670	2AG5	2.89
6	3/8	WP-24,	NP391	53N60	5.49	818-1675	2AG6	2.89
7	7/16	WP-25,	366-2404	53N61	5.59	818-1680	2AG7	2.89
ALUMINA GAS LENS NOZZLES – 1 7/8" LENGTH, LARGE DIAMETER GAS LENS (ALSO ORDER INSULATOR)								
10	5/8	WP-26, WP-26V,	366-2434	53N88	14.50	818-2100	3AG10LD	6.19
12	3/4	WP-12	366-2431	53N87	14.50	818-2110	3AG12LD	6.19
Short	15/16		366-2437	53N89	14.90			



NP396



366-1591



KLETON

**CANADA'S LEADING
MATERIAL HANDLING
SUPPLIER**

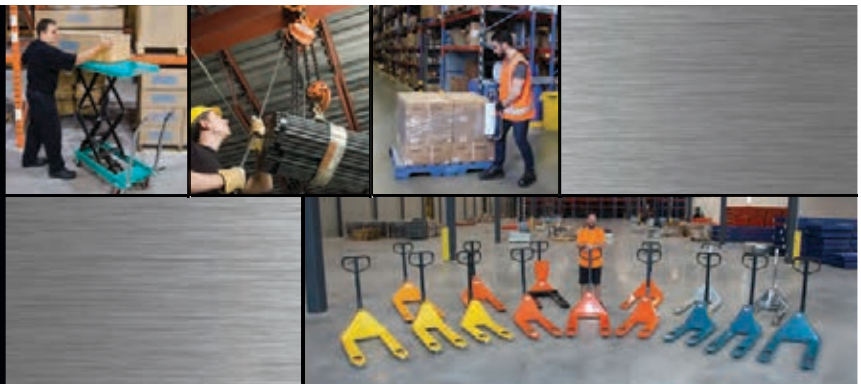



TUNGSTEN ELECTRODES

- Oxides used are primarily zirconium, thorium, lanthanum or cerium
- Additions are 1% - 4%, improve arc initiation, especially when direct current (DC) welding is employed
- Thorium oxide (thoria), effective in terms of long life and thermal efficiency
- Zirconium oxide (zirconia) has been commonly used for alternating (AC) TIG welding, welding aluminum
- Electrode length: 7"
- **Each package contains 10 electrodes**

2% THORIATED:

- Good current capacity, arc stability and easy arc start on DC current
- High resistance to weld pool contamination
- Maintains sharpened tip configuration
- Not normally used on AC current because it is difficult to maintain the balled end

0.8% ZIRCONIATED:

- Excellent for AC welding due to the higher arc stability
- High-resistance to weld pool contamination
- Excellent balled end retention
- Handles higher current with less spitting
- Better arc starts and arc stability than pure tungsten

1.5% LANTHANATED:

- Lowest erosion rate • Wide current range
- No spitting • Best DC arc starts and stability

2% CERIATED:

- Excellent arc starting, stability, long life and higher-current capacity than thoriated tungsten
- Operate successfully with AC or DC current
- Non-radioactive • Low erosion rate
- Wide current range • No spitting

PURE:

- Lowest current capacity and least expensive
- Maintains a clean balled end for welding on AC
- More prone to weld contamination than other types of tungsten electrodes
- Tends to spit at higher currents • Used for non-critical welds only

2% LANTHANATED:

- Non-radioactive
- Best general purpose electrode at medium to higher amperages for both A/C or D/C using inverter or transformer based constant current power sources
- Good for low-alloyed steels, non corroding steels, aluminum alloys, magnesium alloys, titanium alloys, nickel alloys, and copper alloys
- Good arc starts and stability, low erosion rate, medium to high current range

LAYZR™:

- Non-radioactive
- Best for automated or robotic applications in A/C or D/C due to low voltage tolerance (changes in tip to work piece distance) using inverter or transformer based constant current power sources
- Good for low-alloyed steels, non corroding steels, aluminum alloys, magnesium alloys, titanium alloys, nickel alloys, and copper alloys
- Very stable tip geometry runs cooler than 2% thoriated, longer life
- Very best low amperage starts

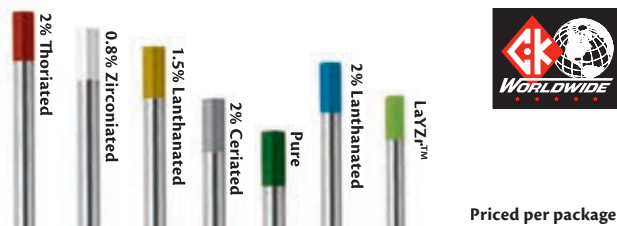

Priced per package

Model No.	Mfg. No.	ISO Colour Chart	Dia. "	Price /Each
2% THORIATED				
TTT403	T0207GT2	Red	0.020	3.49
NP552	T0407GT2	AWS A5.12 EWTh-2	0.040	10.50
NP544	T1167GT2	ISO 6848 WT20	1/16	19.90
NP545	T3327GT2		3/32	44.50
NP543	T187GT2		1/8	78.90
714-1150	TS327GT2		5/32	145.00
0.8% ZIRCONIATED				
TTT408	T0207GZ	White	0.020	3.49
TTT409	T0407GZ	AWS A5.12 EWZr-8	0.040	12.50
NP546	T1167GZ	ISO 6848 WZ8	1/16	20.50
NP547	T3327GZ		3/32	44.90
NP553	T187GZ		1/8	80.90
714-1185	TS327GZ		5/32	149.00
1.5% LANTHANATED				
TTT404	T0207GL	Gold	0.020	3.49
TTT405	T0407GL	AWS A5.12 EWLa-1.5	0.040	11.50
714-1200	T1167GL	ISO 6848 WL15	1/16	19.90
714-1205	T3327GL		3/32	44.50
714-1210	T187GL		1/8	78.90
TTT406	TS327GL		5/32	129.00
2% CERIATED				
TTT407	T0207GC2	Grey	0.020	2.99
NP548	T0407GC2	AWS A5.12 EWCe-2	0.040	10.50
NP549	T1167GC2	ISO 6848 WC20	1/16	18.90
NP550	T3327GC2		3/32	43.50
NP551	T187GC2		1/8	77.90
714-1177	TS327GC2		5/32	129.00
PURE				
TTT410	T0207G	Green	0.020	2.99
NP539	T0407G	AWS A5.12 EWP	0.040	10.50
NP540	T1167G	ISO 6848 WP	1/16	18.90
NP542	T3327G		3/32	43.50
NP541	T187G		1/8	79.90
714-1060	TS327G		5/32	125.00
2% LANTHANATED				
TTV117	T0207GL2	Blue	0.020	3.49
TTV118	T0407GL2	AWS A5.12 EWLa-2	0.040	10.50
TTV119	T1167GL2	ISO 6848 WLZO	1/16	20.50
TTV120	T3327GL2		3/32	44.50
TTV121	T187GL2		1/8	79.90
TTV122	TS327GL2		5/32	129.00
LAYZR™				
TTV111	T0207GTM	Chartreuse (Lime Green)	0.020	3.49
TTV112	T0407GTM	AWS A5.12 EWG	0.040	11.50
TTV113	T1167GTM	ISO 6848	1/16	19.90
TTV114	T3327GTM		3/32	44.50
TTV115	T187GTM		1/8	80.90
TTV116	TS327GTM		5/32	179.00

CHEM-SHARP

CHEMICAL TUNGSTEN SHARPENERS

- Safest way to sharpen tungsten without grinding
- Chemically mills a perfect point on pure, thoriated or titanium type tungsten
- Repoint time is approximately one minute at the work station
- Extends tungsten life four times longer than that of ground tungsten
- 5 oz. net jars, over 500 sharpenings per jar



DYNAFLUX
QUALITY PRODUCTS

Model No.	Mfg. No.	Description	Price /Each
881-1300	DF600-6	Jar, 5 oz. net	27.39
881-1305	DF601-6	Tungsten Holder	48.09
881-1310	DF602-4	Kit w/1 Jar and Holder	79.19

TUNGSTEN STICK-OUT GAUGES

- Made of durable solid brass
- Easily lock-in, correct stick-out from the end of nozzle
- Face of gauge marked in 1/16" indications for easy calculation of required stick-out
- Consistent stick-out adds quality to every weld
- Repeatable for welder to welder

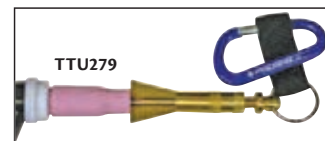

Model No.	Mfg. No.	Description	Price /Each
TTU279	TG1	For Standard Torch	70.90
TTU280	TG1-24	For 24 Series and Micro Torch	67.50



TURBO-SHARP® X TUNGSTEN ELECTRODE GRINDERS

An enclosed electrode grinder, which eliminates grinding dust exposure to both the user and the environment.

- Multifunctional cover - Through a slot in the cover, one can flatten the electrode to prepare a truncated cone
- 3 position adjustment for triple lifetime of grinding disc
- Angles adjustable from 20° to 60°
- Both sides of grinding disc coated with diamond-powder, giving double wheel life
- Allows exact repetition of longitudinal grinding
- Can be connected to vacuum system, accessory included with unit
- Can be equipped with an optional head which can grind electrodes of diameter: 0.040" (1.0 mm), 5/32" (4.0 mm), 3/16" (4.8 mm) or 1/4" (6.4 mm)
- Short tungsten kit grinds tungsten as short as 3/4" and includes 0.040" (1.0 mm), 1/16" (1.6 mm) and 3/32" (2.4 mm) collets

Both side of disc are coated with diamond-powder (double lifetime)



821-3707

TTT414

Short tungsten kit

(Sold separately)
Grinds electrodes as short as 3/4" (19 mm)



Includes: 0.040" (1.0 mm), 1/16" (1.6 mm) and 3/32" (2.4 mm) collets

3 position adjustable head!



Grinding disc last 3x longer!



Turbo-Sharp®



TTT401



Model No.	Mfg. No.	Description	Price /Each
TTT401	TS10	115 V Grinder	1439.00
821-3707	TS3-W	Replacement Diamond Coated Disc Wheel	159.00
TTT413	TS3-HB	Grinder Head - 0.040" -1/8" (included in TTT401)	375.00
821-3706	TS3-HR	Grinder Head - 0.040" - 5/32", 3/16", 1/4"	375.00
TTT414*	TS3-STK	Short Tungsten Kit	225.00

* For use with 821-3706 grinder head only



METAL CARRYING CASE INCLUDES:

- Standard head for diameters: 0.040" (1.0 mm), 1/16" (1.6 mm), 3/32" (2.4 mm) and 1/8" (3.2 mm)
- Accessory for stationary mounting
- Adapter for vacuum cleaning
- Pen style electrode holder
- Multifunctional cover
- Tools for assembling and replacement of grinding wheel
- User instructions



TECHNICAL DATA

Voltage:	120 V or 230 V AC
Single Phase:	60 Hz
Power:	400 W
Amp:	3.5 A
No load speed:	30 000 RPM
Weight:	3.7 lbs. (1690 g)
Guarantee:	2 years

MT200-AC/DC TIG WELDING SYSTEM

CREATE, REPAIR & CUSTOMIZE

- Provides the ability to quickly and efficiently adapt to dynamic welding situations
- High-performance dual voltage inverter for 115V and 220V
- Two dynamic welding modes: GTAW (TIG) and SMAW (Stick)
- Easy-to-use interface allows for quick setting adjustments
- Compact, portable design for use in multiple applications
- Features square wave technology allowing arc to start as low as 5 amps
- **3-year limited warranty**

- **Use to Weld:** Aluminum, Titanium, Magnesium, Stainless Steel, Low Alloy Steel, Deoxidized Copper, and much more!
- **Includes:** CK17 Flex-Head Gas-Cooled TIG Torch with 12.5' Super Flex™ Cable, Dinse® Connector, AK-3 Accessory Kit, Foot Pedal Amperage Control, Ground Clamp with 12.5' Cable, Single-Flow Regulator, 6' Argon Hose, 220V to 115V power adapter



Model No.	Mfg. No.	Input Power Voltage/Phase/Hz	Input Current	Output Current Range		Rated Output		Price Each
				GTAW	SMAW	GTAW	SMAW	
TTV224	MT200-AC/DC	115/1/50/60	21A	115V:	115V:	115V: 140A@15.6V,	115V: 110A@24.4V,	3649.00
				5-140 Amps	10-110 Amps	40% duty cycle	25% duty cycle	
		220/1/50/60	34A	220V:	220V:	220V: 200A@18.0V,	220V: 160A@26.4V,	
				5-200 Amps	10-160 Amps	25% duty cycle	30% duty cycle	



#1 MARKER

MADE FROM DURABLE, LIGHTWEIGHT ALUMINUM

- Curv-O-Mark® Contour® Marker is a compact, time-saving tool used to lay out pipe and structural steel joints
- Laterals at any angle, tees, wyes, crosses, elbows
- Any type or size of joint can be quickly and precisely laid out
- Can be used to lay out pipe from 1-1/2" to 18" diameter, or structural steel members up to 18"
- Consists of an X-shaped frame, calibrated protractor, and a triple-jointed marking arm and holder
- Holder accepts a soapstone crayon (included), felt pen or pencil
- Can be used right side up or upside down, depending on the direction of the line to be scribed
- Protractor calibrated on both sides—one in degrees, the other in rise-inches-per foot—to service any type of measurement need
- Optional combination adaptor accessory allows the marker to lay out joints on larger size pipe, as well as scribe compound angles with just one setting

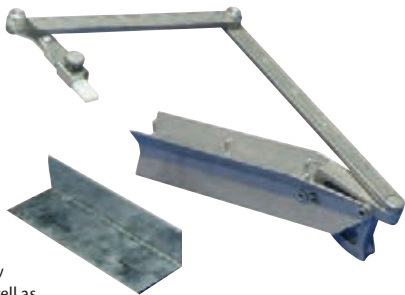

CURV-O-MARK®

Model No. 430-2000

Mfg. No. 14771

Price/Each \$292.00

CENTERING HEADS

Aid in the setting of centerlines, establishing angles and marks for butt-ins, locating points inside pipes and tanks, laying out keyways and measuring declivity.

#6 Standard Model

- Used on pipe 1/2" to 4" diameter or larger
- Fitted with an adjustable dial bubble protractor (DSL), manually operated centering pin

#7 Jumbo Model

- For pipe 1" diameter and up
- Includes DSL
- Spring-loaded hardened centering pin eliminates the need for a hammer
- Align and press the trigger



CURV-O-MARK®

Model No.	Mfg. No.	Type	Head Type	Head Width"	Price /Each
430-2050	14775	Standard	Y	4	157.00
430-2070	14776	Jumbo	Y	8	244.00

RADIUS MARKERS

- Available in four sizes for scribing circles up to 80" diameter
- Folding type design—three smaller models will fit conveniently into a shirt pocket
- All have sturdy friction joints to maintain rigidity and accuracy
- Made from lightweight, rustproof aluminum for long wear
- Soapstone crayon installed in each radius marker
- Scribe holder will accept round, square or flat soapstone crayon, pencil or steel point scribe



CURV-O-MARK®

Model No.	Mfg. No.	Description	Radius"	Price /Each
430-2580	14780	Mini	Up to 8	52.50
430-2590	14781	Small	Up to 20	71.50
430-2600	14782	Standard	Up to 24	76.30
430-2610	14783	Jumbo	Up to 40	125.00

#28 MAGNETIC BURNING GUIDES

- Designed for use with a burning torch or as a straight edge
- Cast of strong, durable material to withstand heat and spatter
- Base has three 30-lb. pull cast-in magnets for use in any position
- 24" blade on a raised plane is standard

Model No. 430-2190

Mfg. No. 14791

Price/Each \$152.00

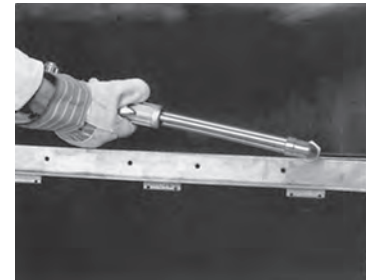

CURV-O-MARK®

#33 UNIVERSAL LEVELS

- Multipurpose tool
- Designed primarily for pipefitting applications, is a valuable tool for any craft required to use a level or plumb bob
- Unit features a 360° adjustable protractor dial set level bubble (DSL) that ensures accurate levelling and permits the following additional uses:
 - Setting a predetermined pitch of a string of pipe
 - Setting the angle of laterals to a precise degree
 - Truing vertical runs
 - Two-holing flanges
- Permits hands-free levelling, for tight spots
- Bubble is mounted on a protractor dial allowing for the level to be used in any position and still read accurately
- Designed to fit any size bolt hole spaced between 2-1/4" to 8" centres on flanges permitting the orientation of flange bolt holes for any size pipe

Model No. 430-2240

Mfg. No. 14796

Price/Each \$235.00



CURV-O-MARK®

WRAP-A-ROUNDS

- An inexpensive tool for marking straight lines around pipe, or for use as a straight edge
- Made of flexible gasket material
- Resistant to heat and cold
- Asbestos free with service temperature of up to 350°F
- Printed with a scale in inches, pitch chart, tangent chart and other useful markings except X-small
- 3.88" and 5.00" wraps feature a metric scale and pitch chart



CURV-O-MARK®

Model No.	Mfg. No.	Size	Dimensions			Pipe Dia."	Price /Each
			L'	x	W"		
430-2330	14752	Medium	4	x	3.88	3 to 6	27.70
430-2370	14753	Large	6	x	3.88	3 to 10	29.40
430-2410	14754	X-Large	7	x	5.00	4 to 12	39.90
430-2450	14756	XX-Large	9	x	5.00	6 to 16	58.70

WELDING & METALWORKING

ER70S6 CARBON STEEL WELDING WIRE

- Highest combination of manganese and silicone deoxidizers
- Permits high current welding with CO₂ gas shielding
- Can also be applied with ArCO₂
- Excellent wetting
- Good for out-of-position welding using short circuiting transfer
- Layer/level wound wire
- Certified by CWB to CSA class W48 for ER49S-6
- Certified by AWS to class A5.18 for ER70S6



NT549



TTU049



Priced per Spool

Model No.	Diameter	Spool Wt.	Spools Per Master Box	Price /Each
NT549	0.023"/0.6 mm	2 lbs./0.9 kg	18	7.95
NT550	0.030"/0.8 mm	2 lbs./0.9 kg	18	5.70
NT551	0.035"/0.9 mm	2 lbs./0.9 kg	18	6.25
NT552	0.045"/1.14 mm	2 lbs./0.9 kg	18	6.50
NT553	0.023"/0.6 mm	11 lbs./5 kg	4	32.70
NT554	0.030"/0.8 mm	11 lbs./5 kg	4	22.80
NT555	0.035"/0.9 mm	11 lbs./5 kg	4	21.35
NT556	0.023"/0.6 mm	33 lbs./15 kg	1	104.00
NT557	0.030"/0.8 mm	33 lbs./15 kg	1	74.10
NT560	0.035"/0.9 mm	44 lbs./20 kg	1	79.95
NT561	0.045"/1.14 mm	44 lbs./20 kg	1	82.95

Priced per Drum

Model No.	Diameter	Drum Weight	Qty Per Pallet	Price /Each
TTU049	0.035"/0.9 mm	550 lbs./250 kg	4	920.00

ATTACHMENTS FOR PRO-MAG BURNING SQUARE & MAGNETIC BURNING GUIDE

- Each is in two sections

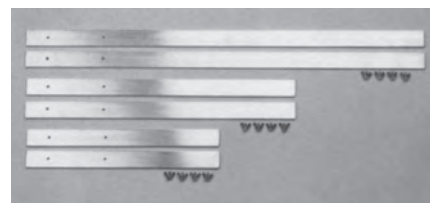

CURV-O-MARK

Model No.	Mfg. No.	No.	Overall Length"	Price /Each
430-2200	14792	29	34	124.00
430-2210	14793	30	48	147.00
430-2220	14794	31	72	185.00

WORKER KITS

All the top sellers in one case!

- Includes: #1 Contour™ Marker, #7 Centering Head, #8 Pro-Mag level, standard Radius Marker, square soapstone, holder and lockable metal carrying case

Model No. TTT484

Mfg. No. 20664

Price/Each \$529.00



CURV-O-MARK

SELF-SHIELDING MILD STEEL FLUX-CORED WELDING WIRE

- Self-shielding—Welds steel without gas
- Gasless steel welding wire for single pass applications
- Excellent for use on thin gauges of galvanised and mild steels



weldcote metals

Priced per Spool

Model No.	Mfg. No.	Dia."	Wt. lbs.	Price /Each
TTU700	E71TGS030X2SP	0.030	2	22.20
TTU701	E71TGS035X2SP	0.035	2	20.90
TTU702	E71TGS030X10SP	0.030	10	96.70
TTU703	E71TGS035X10SP	0.035	10	90.10
TTU704	E71TGS030X25SP	0.030	25	231.00
TTU705	E71TGS035X25SP	0.035	25	227.00
TTU706	E71TGS045X25SP	0.045	25	218.00

MIG WIRE CLEANING PADS

- Designed for use on all MIG wire feeders
- Removes dust and dirt from the wire prior to wire entry into the liner conduit
- Use of wire feed pads can decrease the coefficient of friction in the liner as much as 50%-60% and reduce erratic feed and burn backs
- Treated pads can be used on all alloyed wires except aluminum

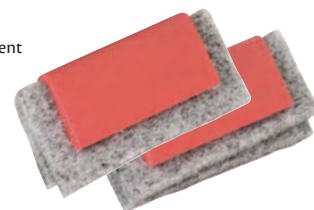

Priced per Package

DYNAFLUX
QUALITY PRODUCTS

Model No.	Qty/Pkg.	Price/Each
720-1000-KIT	6	12.79
720-1010-KIT	24	50.39



MILD STEEL STICK ELECTRODES

• Priced per 5-lb. tube

6010

- High cellulose coated electrode designed to provide a smooth stable arc forceful enough to achieve deep penetration into the base metal
- Produce a flat weld bead with coarse ripples and a thin easily removable slag
- May be used in the flat, horizontal, vertical or overhead welding positions

6011

- A versatile, deep penetrating, all-position electrode for steel
- Offer excellent mechanical properties in the welding of mild steels, galvanized and some low alloy steels
- Operate on AC or DCEP

6013

- A general purpose, all-position electrodes for mild steel
- Establishes a smooth, quiet, medium penetrating arc that is readily maintained with minimal spatter loss
- Slag lifts easily, revealing a finely rippled bead contour
- Ideally suited for general purpose welding, even with small AC power sources having low open-circuit voltage
- Operates on AC, DCEN or DCEP

7014

- An all position electrode for mild and low alloy steels
- Iron powder covering content yields a high deposition rate in all positions
- Particularly advantageous when poor fit-up exists
- Operates on AC, DCEN or DCEP

7018

- A high deposition electrode for low and medium carbon steels
- An efficient, all-position, iron powder, low hydrogen type electrode
- Exhibits excellent mechanical properties, crack resistant, and X-ray quality welds
- Operates on AC or DCEP



36" MILD STEEL CUT LENGTH TIG RODS

• Priced per 10-lb. tube

ER70S-2

This premium quality TIG rod gives welds of the highest quality, even on rust or dirty surfaces due to the deoxidising agents in the wire.

- Can also be used for pipe, plate, and sheet applications where structural integrity is a primary consideration
- AWS A5.18-79

R45

General purpose mild steel rod for TIG or gas welding.

- A general purpose rod used for welding low-carbon sheet, plate and pipe
- Widely used for automotive repair work and is ideal for ornamental art purposes
- AWS A5.2-80

R60

Recommended for gas or TIG welding plate, sheet, pipe, castings, or structural shapes.

- Produces welds of a higher tensile strength than R45
- AWS A5.2-80

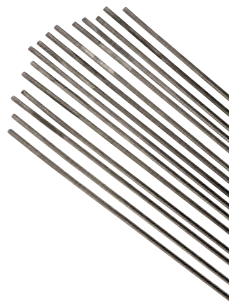

Priced per Tube

Model No.	Mfg. No.	Dia."	Wt. lbs	Price /Each
ER70S-2				
TTU722	E70S2035X36T	0.035	10	89.60
TTU723	E70S2045X36T	0.045	10	88.20
TTU724	E70S2116X36T	1/16	10	79.20
TTU725	E70S2332X36T	3/32	10	66.90
TTU726	E70S218X36T	1/8	10	64.40
TTU727	E70S2532X36T	5/32	10	64.40
R45				
TTU728	R45116X36T	1/16	10	62.70
TTU729	R45332X36T	3/32	10	53.50
TTU730	R4518X36T	1/8	10	50.50
TTU731	R4532X36T	5/32	10	50.50
TTU732	R45316X36T	3/16	10	54.20
R60				
TTU733	R60116X36T	1/16	10	68.30
TTU734	R60332X36T	3/32	10	56.40
TTU735	R6018X36T	1/8	10	53.50
TTU736	R60532X36T	5/32	10	53.50
TTU737	R60316X36T	3/16	10	60.00

Priced per Tube

Model No.	Mfg. No.	Dia."	Wt. lbs.	Price /Each
6010				
TTU707	6010332E5	3/32	5	27.60
TTU708	601018E5	1/8	5	27.40
TTU709	6010532E5	5/32	5	27.40
6011				
TTU710	6011332E5	3/32	5	26.30
TTU711	601118E5	1/8	5	26.10
TTU712	6011532E5	5/32	5	26.10
6013				
TTU713	6013332E5	3/32	5	18.90
TTU714	601318E5	1/8	5	18.70
TTU715	6013532E5	5/32	5	18.70
7014				
TTU716	7014332E5	3/32	5	21.00
TTU717	701418E5	1/8	5	20.80
TTU718	7014532E5	5/32	5	20.80
7018				
TTU719	7018332E5	3/32	5	20.20
TTU720	701818E5	1/8	5	20.10
TTU721	7018532E5	5/32	5	20.10

MILD STEEL STICK ELECTRODES – CWB APPROVED



FLEETWELD® 35 - E6011

- Fill freeze, out-of-position mild steel stick electrodes
- A proven performer for sheet metal welding applications and AC pipe welding
- A great electrode to use on jobs where the steel isn't clean
- AC DC +/-

Priced per Tube

Model No.	Mfg. No.	Diameter"	Wt. kg	Price/Each
TTU006	EDS11006	3/32	4 (8.8 lbs.)	78.50
TTU007	EDS11007	1/8	5 (11 lbs.)	85.50
TTU008	EDS11008	5/32	5 (11 lbs.)	85.50

FLEETWELD® 37 - E6013

- Fill freeze, high speed, mild stick electrodes
- An all-position electrode for low amperage welding on sheet metal, especially in applications where appearance is important
- Ideal for jobs involving irregular or short welds that require a change in positions
- AC DC +/-



Priced per Tube

Model No.	Mfg. No.	Diameter"	Wt. kg	Price/Each
TTU009	EDS11213	3/32	4 (8.8 lbs.)	79.50
TTU010	EDS11011	1/8	5 (11 lbs.)	83.50
TTU011	EDS11012	5/32	5 (11 lbs.)	84.50

FLEETWELD® 47 - E7014

- Fill freeze, high speed, and mild stick electrodes
- Features high deposition rates for fast performance
- Ideal for sheet metal lap joints and fillet welds, general purpose plate welding and maintenance jobs
- AC DC +/-

Priced per Tube

Model No.	Mfg. No.	Diameter"	Wt. kg	Price/Each
TTU012	EDS11016	3/32	4 (8.8 lbs.)	76.50
TTU013	EDS11017	1/8	5 (11 lbs.)	85.90
TTU014	EDS11018	5/32	5 (11 lbs.)	81.90

ER308L, ER309L & ER316L STAINLESS STEEL WELDING WIRE



- Stainless steel spooled wires and cut lengths are precisely produced to conform to the requirements of AWS A5.9
- Manufactured to exacting standards with particular attention given to cleanliness, concentricity and helix of the finished product



Priced per Spool

Model No.	Mfg. No.	Dia."	Wt. lbs.	Price/Each
ER308L SPOOLED WIRE				
TTU760	308L025X2SP	0.025	2	39.10
TTU751	308L025X10SP	0.025	10	150.00
TTU738	308L025X25SP	0.025	25	426.00
TTU761	308L030X2SP	0.030	2	33.80
TTU752	308L030X10SP	0.030	10	140.00
TTU739	308L030X25SP	0.030	25	345.00
TTU762	308L035X2SP	0.035	2	32.20
TTU753	308L035X10SP	0.035	10	140.00
TTU740	308L035X25SP	0.035	25	345.00
TTU741	308L045X25SP	0.045	25	342.00
TTU742	308L116X25SP	1/16	25	341.00
ER309L SPOOLED WIRE				
TTU754	309L025X10SP	0.025	10	221.00
TTU763	309L030X2SP	0.030	2	43.70
TTU755	309L030X10SP	0.030	10	201.00
TTU743	309L030X25SP	0.030	25	466.00
TTU764	309L035X2SP	0.035	2	41.90
TTU756	309L035X10SP	0.035	10	201.00
TTU744	309L035X25SP	0.035	25	462.00
TTU745	309L045X25SP	0.045	25	458.00
TTU746	309L116X25SP	1/16	25	432.00
ER316L SPOOLED WIRE				
TTU765	316L025X2SP	0.025	2	53.70
TTU757	316L025X10SP	0.025	10	217.00
TTU766	316L030X2SP	0.030	2	49.60
TTU758	316L030X10SP	0.030	10	194.00
TTU747	316L030X25SP	0.030	25	463.00
TTU767	316L035X2SP	0.035	2	49.40
TTU759	316L035X10SP	0.035	10	192.00
TTU748	316L035X25SP	0.035	25	463.00
TTU749	316L045X25SP	0.045	25	460.00
TTU750	316L116X25SP	1/16	25	473.00

36" STAINLESS STEEL CUT LENGTH TIG RODS

- **308L** - For joining 304 and 304L and other 18-8 stainless steels
- **309L** - For 309 stainless steels and joining carbon steels or low alloy steels to stainless steels
- **316L** - For joining 316L stainless steels
- Priced per 10-lb. tube



Priced per Tube

Model No.	Mfg. No.	Dia."	Wt. lbs.	Price/Each
308L				
TTU768	308L030X36T	0.030	10	147.00
TTU769	308L035X36T	0.035	10	146.00
TTU770	308L045X36T	0.045	10	134.00
TTU771	308L116X36T	1/16	10	132.00
TTU772	308L332X36T	3/32	10	131.00
TTU773	308L18X36T	1/8	10	131.00
TTU774	308L532X36T	5/32	10	131.00
TTU775	308L316X36T	3/16	10	140.00
309L				
TTU776	309L035X36T	0.035	10	190.00
TTU777	309L045X36T	0.045	10	187.00
TTU778	309L116X36T	1/16	10	179.00
TTU779	309L332X36T	3/32	10	178.00
TTU780	309L18X36T	1/8	10	178.00
TTU781	309L532X36T	5/32	10	183.00
316L				
TTU782	316L030X36T	0.030	10	191.00
TTU783	316L035X36T	0.035	10	189.00
TTU784	316L045X36T	0.045	10	182.00
TTU785	316L116X36T	1/16	10	181.00
TTU786	316L332X36T	3/32	10	179.00
TTU787	316L18X36T	1/8	10	179.00
TTU788	316L532X36T	5/32	10	179.00
TTU789	316L316X36T	3/16	10	179.00

STAINLESS STEEL GAS SHIELD FLUX-CORED WIRE



Precisely formulated for all-position versatility with a smooth arc, good wetting and overall operator appeal. Products conform to AWS Specification A5.22.

308LT1-1

Most frequently used for base metals of similar composition such as AISI Types 301, 302, 304, 305 and 308.

309LT1-1

Used for welding similar alloys in wrought or cast form; occasionally, to weld Type 304 base metals when severe corrosion conditions exist; and, at times, welding dissimilar steels.

316LT1-1

Used for welding similar alloys (containing about 2% molybdenum); also for high temperature service applications (the presence of molybdenum provides increased creep resistance at elevated temperatures).



TTU790



TTU793



TTU796

Priced per Spool

Model No.	Mfg. No.	Dia."	Wt. lbs.	Price /Each
308LT1-1				
TTU790	308LT11035X25SP	0.035	25	725.00
TTU791	308LT11045X25SP	0.045	25	552.00
309LT1-1				
TTU793	309LT11035X25SP	0.035	25	724.00
TTU794	309LT11045X25SP	0.045	25	622.00
TTU795	309LT11116X25SP	1/16	25	609.00
316LT1-1				
TTU796	316LT11035X25SP	0.035	25	713.00
TTU797	316LT11045X25SP	0.045	25	636.00

STAINLESS STEEL ELECTRODES



- Exactly manufactured to conform to the requirements of AWS5.4
- Priced per 5 or 10-lb. tube



Priced per Tube

Model No.	Mfg. No.	Dia." x Length"	Wt. lbs.	Price /Each
308L-16				
TTU799	308L16116E	1/16 x 10	5	146.00
TTU800	308L16332E	3/32 x 12	10	129.00
TTU801	308L1618E	1/8 x 14	10	136.00
TTU802	308L16532E	5/32 x 14	10	136.00
TTU803	308L16316E	3/16 x 14	10	136.00
309L-16				
TTU804	309L16332E	3/32 x 12	10	163.00
TTU805	309L1618E	1/8 x 14	10	163.00
TTU806	309L16532E	5/32 x 14	10	163.00
TTU807	309L16316E	3/16 x 14	10	164.00
316L-16				
TTU808	316L16332E	3/32 x 12	10	167.00
TTU809	316L1618E	1/8 x 14	10	167.00
TTU810	316L16532E	5/32 x 14	10	167.00
TTU811	316L16316E	3/16 x 14	10	167.00

WELDING & METALWORKING

DEOXIDIZED COPPER WELDING WIRE

- Recommended for welding applications where joints of high copper content are involved
- Deoxidized copper contains phosphorus and silicon as de-oxidizing agents which promote sound weld joints
- Produces trouble-free welds that are a good colour match to copper and have good electrical conductivity
- Can be used with inert gas arc and oxyacetylene welding
- Each container has an identification label showing grade, size, weight and heat number
- AWS A5.7, ErCu



Priced per Spool

Model No.	Mfg. No.	Dia."	Wt. lbs.	Price/Each
TTU812	D0C035X30SP	0.035	30	1227.00
TTU813	D0C045X30SP	0.045	30	1216.00
TTU814	D0C116X30SP	1/16	30	516.00
TTU815	D0C332X30SP	3/32	30	634.00

36" CUT LENGTH				
Priced per Tube				
Model No.	Mfg. No.	Dia."	Wt. lbs.	Price/Each
TTU827	D0C116X36T	1/16	10	317.00
TTU828	D0C332X36T	3/32	10	370.00
TTU829	D0C18X36T	1/8	10	294.00
TTU830	D0C316X36T	3/16	10	270.00

SILICON BRONZE WELDING WIRE

- Used for inert gas arc welding of copper, copper-silicon, and copper-based metals to themselves as well as to steel
- Frequently used to gas tungsten arc and gas metal arc weld coated steels
- Also used to surface areas subject to corrosion
- Each container has an identification label showing grade, size, weight and heat number
- AWS A5.27, ERCuSi-A
- Conformance certifications can be furnished upon request



Priced per Spool

Model No.	Mfg. No.	Dia."	Wt. lbs.	Price/Each
TTU824	S1B030X2SP	0.030	2	66.90
TTU825	S1B035X2SP	0.035	2	66.90
TTU826	S1B045X2SP	0.045	2	56.00
TTU820	S1B025X10SP	0.025	10	367.00
TTU821	S1B030X10SP	0.030	10	349.00
TTU822	S1B035X10SP	0.035	10	348.00
TTU823	S1B045X10SP	0.045	10	346.00
TTU816	S1B030X30SP	0.030	30	1144.00
TTU817	S1B035X30SP	0.035	30	1118.00
TTU818	S1B045X30SP	0.045	30	1060.00
TTU819	S1B116X30SP	1/16	30	1048.00

36" CUT LENGTH				
Priced per Tube				
Model No.	Mfg. No.	Dia."	Wt. lbs.	Price/Each
TTU831	S1B035X36T	0.035	10	407.00
TTU832	S1B045X36T	0.045	10	402.00
TTU833	S1B116X36T	1/16	10	332.00
TTU834	S1B332X36T	3/32	10	331.00
TTU835	S1B18X36T	1/8	10	331.00
TTU836	S1B532X36T	5/32	10	349.00
TTU837	S1B316X36T	3/16	10	349.00
TTU838	S1B14X36T	1/4	10	349.00

36" BARE NICKEL SILVER CUT LENGTH TIG RODS

- Recommended for applications requiring higher mechanical properties and situations where good colour match is important
- Primarily intended for braze welding steel and cast iron
- Melting point of 1680°F (916°C)
- RBCuZn-D
- Priced per 10-lb. tube



Priced per Tube

Model No.	Mfg. No.	Dia."	Wt. lbs.	Price/Each
TTU851	NS116X36T	1/16	10	349.00
TTU852	NS332X36T	3/32	10	349.00
TTU853	NS18X36T	1/8	10	349.00
TTU855	NS14X36T	1/4	10	349.00

36" LOW FUMING BRONZE CUT LENGTH TIG RODS



- Fuming qualities and good mechanical properties makes it a widely used general purpose rod
- Provides higher mechanical properties than obtainable with naval bronze
- Used extensively for braze welding steel and cast iron
- Melting point of 1620°F (882°C)
- RBCuZn-C
- Priced per 10-lb. tube

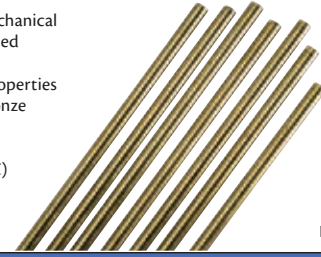

Priced per Tube

Model No.	Mfg. No.	Description	Dia."	Wt. lbs.	Price/Each
TTU839	LFB116X36T	Bare	1/16	10	278.00
TTU840	LFB332X36T	Bare	3/32	10	278.00
TTU841	LFB18X36T	Bare	1/8	10	278.00
TTU842	LFB532X36T	Bare	5/32	10	278.00
TTU843	LFB316X36T	Bare	3/16	10	278.00
TTU844	LFB14X36T	Bare	1/4	10	278.00
TTU845	LFB516X36T	Bare	5/16	10	278.00
TTU846	LFB38X36T	Bare	3/8	10	278.00
TTU847	LFBC332X36T	Flux-Coated	3/32	10	282.00
TTU848	LFBC18X36T	Flux-Coated	1/8	10	259.00
TTU849	LFBC532X36T	Flux-Coated	5/32	10	270.00
TTU850	LFBC316X36T	Flux-Coated	3/16	10	270.00

4043 & 5356 ALUMINUM WELDING WIRE

- Cleanliness, density and temper of wires are precisely controlled
- Each container has an identification label showing grade, size, weight and heat number
- Conform to AWS A5.10 classification, CWB and ABS approvals



4043

- 5% silicon all position aluminum weld wire used to weld heat treatable alloys such as the 6XXX base metals and cast alloys
- Found in many common welding applications such as bicycles, trucks, trailers and automotive parts and equipment
- Silicon with these alloys give improved wetting action yielding a less crack sensitive bright weld bead



Priced per Spool

5356

- 5% magnesium all position non-heat treatable wire used to weld the 5XXX series alloys
- Common welding applications such as boats, ships, bicycles, trucks, pressure vessels and automotive parts and equipment

Model No.	Mfg. No.	Dia."	Wt. lbs.	Price/Each
4043				
TTU956	40430301SP	0.030	1	17.80
TTU957	40430351SP	0.035	1	16.80
TTU958	4043641SP	3/64	1	16.10
TTU959	40430305SP	0.030	5	102.00
TTU960	40430355SP	0.035	5	95.40
TTU961	404303016SP	0.030	16	314.00
TTU962	404303516SP	0.035	16	299.00
TTU963	40436416SP	3/64	16	249.00
TTU964	404311616SP	1/16	16	282.00

5356

TTU965	53560301SP	0.030	1	20.00
TTU966	53560351SP	0.035	1	19.20
TTU967	53563641SP	3/64	1	19.00
TTU968	53560305SP	0.030	5	104.00
TTU969	53560355SP	0.035	5	97.50
TTU020	53563645SP	3/64	5	91.90
TTU970	535603016SP	0.030	16	324.00
TTU971	535603516SP	0.035	16	299.00
TTU972	535636416SP	3/64	16	282.00
TTU973	535611616SP	1/16	16	293.00

36" CUT LENGTH

Priced per Package				
4043				
Model No.	Mfg. No.	Dia."	Wt. lbs.	Price/Each
TTU974	404311636T	1/16	10	156.00
TTU975	404333236T	3/32	10	139.00
TTU976	40431836T	1/8	10	139.00
TTU977	404353236T	5/32	10	156.00
TTU978	404331636T	3/16	10	156.00

5356

TTU979	535611636T	1/16	10	177.00
TTU980	535633236T	3/32	10	148.00
TTU981	53561836T	1/8	10	156.00
TTU982	535653236T	5/32	10	167.00
TTU983	535631636T	3/16	10	156.00

COMMON WIRE SOLDERS

- With some exceptions, the tin/lead solders can be used to solder copper and most copper alloys, lead, nickel alloys and steel
- Heat sources include soldering guns, irons and torch applications
- **Acid Core:** For soldering materials with poor solderability, stainless steel application
- **Rosin Core:** For electrical application
- **Tin/Antimony 95/5:** Useful for applications where moderately elevated temperatures is a factor. It has a high electrical conductivity and high fluidity, recommended where lead contamination must be avoided; not recommended for use on brass or HVAC connections

CAUTION: Lead-bearing solders are not to be used in potable water systems

Priced per Spool

Model No.	Mfg. No.	Description	Specifications	Solidus	Liquidus	Price /Each
40% TIN/60% LEAD SOLID						
TTU888	4060116X1SP	1/16" x 1# Spool	ASTM-B32, Sn-40A	362°F	460°F	77.30
TTU889	4060332X1SP	3/32" x 1# Spool	-	183°C	238°C	74.60
TTU890	406018X1SP	1/8" x 1# Spool	-	-	-	102.00
50% TIN/50% LEAD SOLID						
TTU891	5050116X1SP	1/16" x 1# Spool	ASTM-B32, Sn-50	362°F	420°F	125.00
TTU892	5050332X1SP	3/32" x 1# Spool	-	183°C	215°C	57.10
TTU893	505018X1SP	1/8" x 1# Spool	-	-	-	121.00
50% TIN/50% LEAD ACID CORE						
TTU894	5050AC116X1SP	1/16" x 1# Spool	ASTM-B32, Sn-50	362°F	420°F	64.10
TTU895	5050AC332X1SP	3/32" x 1# Spool	-	183°C	215°C	125.00
TTU896	5050AC18X1SP	1/8" x 1# Spool	-	-	-	122.00
TTU897	5050AC18X5SP	1/8" x 5# Spool	-	-	-	278.00



TTU891

Priced per Spool

Model No.	Mfg. No.	Description	Specifications	Solidus	Liquidus	Price /Each
50% TIN/50% LEAD ROSIN CORE						
TTU898	5050RC116X1SP	1/16" x 1# Spool	ASTM-B32, Sn-50	362°F	420°F	126.00
TTU899	5050RC332X1SP	3/32" x 1# Spool	-	183°C	215°C	125.00
TTU900	5050RC18X1SP	1/8" x 1# Spool	-	-	-	67.60
95% TIN/5% ANTIMONY SOLID						
TTU902	955116X1SP	1/16" x 1# Spool	ASTM-B32, Sb-5	450°F	464°F	214.00
TTU903	955332X1SP	3/32" x 1# Spool	-	232°C	240°C	90.90
TTU904	95518X1SP	1/8" x 1# Spool	-	-	-	94.50

36" CUT LENGTH TIG RODS – POINT OF PURCHASE PACKAGED ALLOYS

- Convenient small package is ideal for maintenance and repair job
- MSDS are packaged in each tube
- 1-lb. tube



TTU932



TTU922



TTU938



TTU949

Priced per Tube

Model No.	Mfg. No.	Diameter"	Wt. lbs.	Price /Each
308L – STAINLESS STEEL				
TTU921	308L116X36T1P	1/16	1	20.80
TTU922	308L332X36T1P	3/32	1	20.60
TTU923	308L18X36T1P	1/8	1	20.60
309L – STAINLESS STEEL				
TTU924	309L116X36T1P	1/16	1	24.00
TTU925	309L332X36T1P	3/32	1	23.50
TTU926	309L18X36T1P	1/8	1	23.50
316L – STAINLESS STEEL				
TTU927	316L116X36T1P	1/16	1	25.20
TTU928	316L332X36T1P	3/32	1	24.90
TTU929	316L18X36T1P	1/8	1	24.90
4043 – ALUMINUM				
TTU930	4043116X36T1P	1/16	1	22.20
TTU931	4043332X36T1P	3/32	1	21.40
TTU932	404318X36T1P	1/8	1	21.40
5356 – ALUMINUM				
TTU933	5356116X36T1P	1/16	1	23.50
TTU934	5356332X36T1P	3/32	1	22.60
TTU935	535618X36T1P	1/8	1	21.20
ER70S-2 – TRIPLE DEOXIDIZED STEEL				
TTU936	ER70S2116X36T1P	1/16	1	14.80
TTU937	ER70S2332X36T1P	3/32	1	13.50
TTU938	ER70S218X36T1P	1/8	1	13.20

Priced per Tube

Model No.	Mfg. No.	Diameter"	Wt. lbs.	Price /Each
LOW FUMING BRONZE - BARE				
TTU942	LFB116X36T1P	1/16	1	34.20
TTU943	LFB332X36T1P	3/32	1	34.20
TTU944	LFB18X36T1P	1/8	1	34.20
LOW FUMING BRONZE – FLUX-COATED				
TTU945	LFBC116X36T1P	3/32	1	34.60
TTU946	LFBC18X36T1P	1/8	1	33.80
R45 – MILD STEEL				
TTU947	R45116X36T1P	1/16	1	12.70
TTU948	R45332X36T1P	3/32	1	11.80
TTU949	R4518X36T1P	1/8	1	11.50
R60 – HIGH TENSILE MILD STEEL				
TTU950	R60116X36T1P	1/16	1	13.20
TTU951	R60332X36T1P	3/32	1	12.00
TTU952	R6018X36T1P	1/8	1	17.70
SIB – SILICON BRONZE				
TTU953	SIB116X36T1P	1/16	1	44.00
TTU954	SIB332X36T1P	3/32	1	43.70
TTU955	SIB18X36T1P	1/8	1	43.70

VALVE ACTION® PAINT MARKERS

- Ideal for marking on steel and iron, plastic, glass, pipes and tubes, rubber and tires, and textiles
- Fast drying and lead-free paint marker
- Weather and fade resistant
- Replaceable fibre tip ensures full use of the marker



MARKAL

Priced per Marker

Model No.	Description	Price /Each
PA418	White	6.29
PA419	Yellow	6.29
PA420	Red	6.29
PA421	Blue	6.29
PA422	Green	6.29
PA423	Aluminum	6.59
PA431	Black	6.29
PE935	Fluorescent Yellow	6.59
PE936	Fluorescent Green	6.59
PE937	Fluorescent Orange	6.59
PE938	Fluorescent Pink	6.59
PA424	Replacement Tips (Pkg. of 12)	13.90

PRO-LINE® FINE LINE MARKERS

- High strength, lightweight barrel for industrial use
- Ideal for metal, suitable for wood, glass, plastic and rubber
- Xylene-free
- Self-storing cap with integrated pocket clip



MARKAL



Priced per Marker

Model No.	Colour	Price /Each
PC461	White	6.69
PC462	Yellow	6.69
PC463	Black	6.69

THERMOMELT® HEAT STIK TEMPERATURE INDICATORS

ACCURATE SURFACE TEMPERATURE MEASUREMENT STICKS

- 33% bigger and stronger than competitive brands
- Accurate, fast, low-cost method for measuring surface temperatures
- When desired temperature is reached, the mark quickly melts to a glossy, transparent-appearing liquid
- Accurate to +/-1% of stated Fahrenheit temperature
- Ideal for applications such as annealing, forging, welding, bending, forming and any place where temperature measuring is necessary
- Meets ANSI/ASME guidelines



Priced per Heat Stik

Model No.	Mfg. No.	Temperature °F/°C	Price /Each
HK860	86517	200/93	22.50
434-7260	86562	250/121	22.50
HK887	86625	300/149	22.50
434-7410	86697	350/177	22.90

SOLID PAINT MARKERS FOR COLD SURFACES

B® PAINTSTIK®
The Original ALL Purpose
Cold Surface Marker -50° to 150°F

MARKAL



Real paint in stick form. Ideal for long-lasting, weather, fade and abrasion resistant identification. Leaves bright, highly visible marks on all materials, including asphalt, aluminum, glass, plastic, marble, lumber and steel. Writes on rough, smooth, oily, wet, icy and rusty surfaces.

Priced per Paintstik

Model No.	Colour	Price /Each
PA298	White	2.79
PA309	Yellow	2.79
PA320	Black	2.79

B-L® BLUE PAINTSTIK® -50° TO 150°F

Makes permanent marks that bleed through painted surfaces. Available in blue only. 12 dozen/case.

Priced per Paintstik

Model No.	Colour	Price /Each
PA356	Blue	9.39

PRO-LINE® HP PAINT MARKERS

MARKAL

- High performance paint marker has unsurpassed writing capabilities on oily surfaces
- Excellent on most metals, coatings, plastics, glass, ceramics and other non-porous materials
- Low in halogenated compounds and sulphur allowing use in stainless steel and other corrosion sensitive applications



Priced per Marker

Model No.	Colour	Price /Each
PE507	White	6.09
PE508	Yellow	6.09
PE509	Red	6.09
PE510	Black	6.09

LUMBER CRAYONS

-50° TO 150°F

- Weather and fade-resistant lead-free marking
- Use on cardboard, ceramics, concrete, lumber (rough or smooth), metal, plastics, rubber, shipping room, storage containers



MARKAL

Priced per Crayon

Model No.	Colour	Price /Each
ECONOMICAL WAX BASED #200		
PA371	Black	2.09
PA367	White	2.09
PA368	Yellow	2.09

QUIK STIK® TWIST-UP PAINT MARKERS

- All purpose paint marker for marking metal, wood, glass, plastic, cardboard and more
- Fast drying paint is fade and weather resistant
- 20% more marks than other brands
- Easy-to-use twist-up holder with self-storing cap keeps hands and clothing clean
- 72 per case

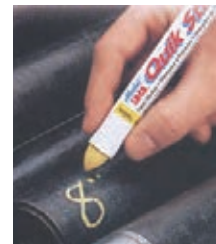

MARKAL



Priced per Marker

Model No.	Colour	Price /Each
PB937	White	12.90
PB938	Yellow	12.90
PB939	Red	12.90
PB940	Black	12.90

FLUORESCENT

OP543	Yellow	14.50
OP544	Green	14.50
OP545	Orange	14.50
OP546	Pink	14.50

TRADES-MARKER® ALL PURPOSE MARKERS

RETRACTABLE GREASE PENCILS SUITABLE FOR ALL SURFACES

- Retractable grease pencil offers more convenience and longevity than a standard china marker
- Marks on plastic, glass, metal, wood, cardboard and paper
- Will not rub off and are weather-resistant
- Includes handy pocket clip
- Holder comes with 5 refills
- Refills come six per package
- Two dozen per case



434-9910

434-8980

MARKAL

Priced per Marker

Model No.	Mfg. No.	Colour	Price/Each
HOLDER W/5 REFILLS			
434-8980	96000	-	19.50
REFILLS, 6/PKG.			
434-9915	96009	Orange	11.90
434-8985	96042	White	11.90
434-9910	96043	Yellow	11.90
434-8995	96044	Black	11.90
434-9920	96045	Red	11.90

WHITE PASTE BRAZING FLUX

- For use with silver brazing alloys on all metal other than aluminum, magnesium or titanium
- Effective to 1600°F
- Meets AMS 3410, AWS A5.31-92, Type FB3A, Fed Spec. 0-F-499, Type B



Model No.	Mfg. No.	Size	Price /Each
TTU906	WPFLUX14JAR	1/4 lb.	18.50
TTU907	WPFLUX12JAR	1/2 lb.	25.50
TTU908	WPFLUX1JAR	1 lb.	33.40
TTU909*	WPFLUX6OZ	6 oz.	24.20

*Comes with brush cap



TTU908

GENERAL PURPOSE LIQUID SOLDERING FLUX

- Water-based, inorganic-acid flux formulated for virtually all metals other than aluminum, magnesium or titanium
- Contains Zinc Chloride, Ammonium Chloride, and Hydrochloric Acid, makes this flux active at room temperature where it begins to clean metals and remove oxides
- Pre-cleaning is not necessary under most conditions



Model No.	Mfg. No.	Size	Price /Each
TTU915	LIQUIDFLUX4OZ	4 oz.	20.10
TTU916	LIQUIDFLUX16OZ	16 oz.	35.70
TTU917	LIQUIDFLUX1GL	1 Gallon	162.00



TTU915

BLACK PASTE BRAZING FLUX

- Use with silver or other brazing alloys liquidus below 1800°F
- Recommended for stainless, heavy parts and whenever heating cycle is prolonged
- For all metals other than aluminum, magnesium or titanium
- Meets AMS 3411, AWS 5.31, Class FB3C; Fed. Spec. 0-F-499D, Type B



Model No.	Mfg. No.	Size	Price /Each
TTU911	BPFLUX12JAR	1/2 lb.	28.00
TTU912	BPFLUX1JAR	1 lb.	37.30
TTU913	BPFLUX5JAR	5 lb.	179.00



TTU911

GENERAL PURPOSE PASTE SOLDERING FLUX

- Excellent flux for joining copper to copper, and copper to brass
- Not recommended for electrical or electronic applications
- Effective to 700°F
- Meets Fed. Spec. 0-F 506C, Type 1, Form A and MIL-S-6872A



Model No.	Mfg. No.	Size	Price /Each
TTU918	PASTEFLUX4OZ	4 oz.	20.30
TTU919	PASTEFLUX16OZ	16 oz.	49.40



TTU919

WHITE ANTIBORAX FLUX

- General purpose brazing flux
- Use with low fuming bronze and nickel bronze brazing alloys
- Highly active powder flux has applications in brazing steel, cast irons and copper-base alloys
- Active in a heat range between 1400° and 2200°F
- Meets MIL-F-16136B, Types A and B, AWS 5.31-91, Type FB3J



Model No.	Mfg. No.	Size	Price /Each
TTU914	WPWDFLUX1JAR	1 lb.	28.50



TTU914

CAST IRON FLUX

- A powder flux for welding cast iron
- Use with any commercial cast iron torch welding alloy
- Specially prepared to produce better results on "problem" cast iron
- Wide active heat range of 1400° to 2200°F eliminates the necessity of several different fluxes



Model No.	Mfg. No.	Size	Price /Each
TTU920	CASTIRONFLUX1JR	1 lb.	67.10



TTU920

ACID/FLUX BRUSHES

- Perfect brushes for applying liquid or paste flux



Model No.	Mfg. No.	Width"	Trim Length"	Overall Length"	Price /Each
BY189	74059	1/4	11/16	6	0.32
BY190	74060	3/8	7/8	6 1/8	0.53
BY191	74061	7/16	7/8	6 1/8	0.37
BY192	74062	9/16	7/8	6 1/8	0.64

AL-BRAZE E.C. ALUMINUM BRAZING FLUX

- Powdered flux is recommended to use with 4047 (formerly 718) brazing alloy, and other aluminum brazing alloys
- May be mixed with water or alcohol to form a paste
- Meets specs AMS 3412, AWS A5.31 Type FB1A



Model No.	Mfg. No.	Size	Price /Each
841-1137	ECDF1/2	8 oz.	61.80



WELDING & METALWORKING

WELD-KLEEN® ANTI-SPATTER

- Base metal and fixture applications become easier to clean and remove unwanted weld spatter
- Regular use of these products reduces the need for grinding and other clean-up tasks
- Cuts costs by reducing downtime



WELD-KLEEN® 350°

- Effective water-based product designed for use on most base metal applications
- Economical and safe
- Biodegradable, non-toxic and paintable
- Can be frozen
- Available in a safe and convenient aerosol powered by air

WELD-KLEEN® HEAVY-DUTY

- A convenient solvent based, quick-drying aerosol that allows for pre-heat, higher duty cycles and higher temperature applications
- Excellent for fixture and tooling protection
- Paintable, non-flammable, no fluorocarbons

WELD-KLEEN® 350° SPRAYER

- Hand sprayer with 36" lead tube for gallon container



388-1180



388-1165



388-1175

Model No.	Mfg. No.	Description	Size	Price /Each
388-1175	007090	Weld-Kleen® 350°	1 Gallon	27.50
388-1185	007091	Weld-Kleen® 350°	5 Gallons	139.00
388-1180	007092	Weld-Kleen® 350°	55-Gallon Drum	1079.00
388-1165	007030	Weld-Kleen® H-D	20-oz. Aerosol	19.50

LUBE-MATIC®

- Engineered to clean and lubricate wire, improve feedability, reduce spatter and increase tip and liner life
- Lube-Matic® pads and liquid help keep liners free of unwanted build-up and deposits inside the liner that cause wire drag
- Reduces wire drag by 60% and feeds wire more smoothly with poor cast, helix and rust
- Best when used together, as a system to clean and feed wire

LUBE-MATIC® LUBE PADS

- Black lube pads are pre-treated with Lube Matic® liquid
- Lubrication allows smooth feeding of wires with poor cast, helix, rust and long feed liners

LUBE-MATIC® WIRE KLEENER® PADS

- Red Kleener® pads are for all wires all the time
- Last chance to clean wire and reduce burn back 50%



388-1010



Model No.	Mfg. No.	Description	Size	Price /Each
388-1010	007060	Lube-Matic® Lube Pads	6/Pkg.	14.90
388-1190	007061	Lube-Matic® Wire Kleener® Pads	6/Pkg.	12.90

NOZZLE-KLEEN®

- The accumulation of spatter on nozzles and tips can lead to poor gas coverage resulting in poor welds
- Preventing spatter build-up will increase weld quality and reduce costly downtime
- Maintain a clean nozzle
- Eliminate build-up with a spray or dip



388-1145

388-1150

NOZZLE-KLEEN #2°

- Highest quality for most applications
- Non-flammable and paintable
- No fluorocarbons

NOZZLE-KLEEN® HEAVY-DUTY

- Used for highest temperature applications including pulsed welding and argon rich mixtures
- Outstanding fixture protection
- Excellent for stainless steel
- Non-flammable, paintable no fluorocarbons and ozone friendly

Model No.	Mfg. No.	Description	Size	Price /Each
388-1150	007022	Nozzle-Kleen® #2	16-oz. Aerosol	16.90
388-1145	007020	Nozzle-Kleen® H-D	16-oz. Aerosol	17.90

SOAPSTONE HOLDERS



- Durable marking tools for holding fragile marking materials like soapstone and chalk
- Soapstone features highly visible white marking stick cut from natural stone which adheres to metal, stone, concrete and fabrics
- Pocket clip
- Sold with one soapstone installed

ROUND HOLDERS

- Aluminum adjustable holder for 1/4" x 5" soapstone or chalk

FLAT HOLDERS

- Steel adjustable holder for 1/2" x 5" flat soapstone or chalk
- Locking nut soapstone length adjustment



Model No.	Description	Price/Each
NT638	Round Holder	4.60
NT639	Flat Holder	4.35

SOAPSTONES

- White soapstone
- Sold in box quantity of 144



Priced per Box

Model No.	Description	L" x W" x H"	Price/Each
NT226	Round Soapstone	5 x 1/4 x 1/4	44.10
NT225	Flat Soapstone	5 x 1/2 x 3/16	33.80

MIG WIRE CLEANING PADS

- Designed for use on all MIG wire feeders
- Removes dust and dirt from the wire prior to wire entry into the liner conduit
- Use of wire feed pads can decrease the coefficient of friction in the liner as much as 50%-60% and reduce erratic feed and burn backs
- Treated pads can be used on all alloyed wires except aluminum

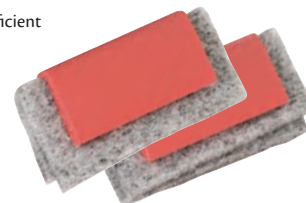

Priced per Package

Model No.	Qty/Pkg.	Price/Each
720-1000-KIT	6	12.79
720-1010-KIT	24	50.39

DEFENSE ANTI-FREEZE & PUMP LUBRICANTS

- Provides year round pump protection for water coolers and closed loop water systems
- Contains a lubricant additive providing continuous pump lubrication during operation
- Prolongs seal and shaft life because of its silicate free formula
- Protects from freezing to -30°F when undiluted (a dilution of two parts Defense to one part water protects to -10°F) except for pre-mixed formula, protects to 10°F

Note: Although Defense is a permanent anti-freeze and pump lubrication solution, it should be changed annually to maintain maximum anti-freeze protection and pump lubrication.

DYNAFLUX
QUALITY PRODUCTS

Model No.	Mfg. No.	Size	Price /Each
881-1355	DF927-PM	1 Gallon, Pre-Mixed	50.29
881-1350	DF929-4x1	1 Gallon	78.69
	DF929-5	Case of 2 x 2.5 gal. Jugs	374.00
881-1370	DF929-55	55-Gallon Drum	3309.00



881-1355

881-1350

SPRAY GALV/COLD GALV

ZINC GALVANIZING COATING

- Produces hard zinc coating that will stop rust and corrosion on all metal surfaces
- Compounded from 95.1% metallic zinc dust
- Equal to hot dip galvanizing in cathodic protection and film durability
- Meets or exceeds military specs

DYNAFLUX
QUALITY PRODUCTS

Model No.	Mfg. No.	Description	Size	Price /Each
877-1125	DF309-16	Spray Galv	13-oz. Net Wt. Aerosol	26.90
877-1130	DF306-6x1	Cold Galv	1 Quart	176.00
877-1120	DF306-2x1	Cold Galv	1 Gallon	701.00



877-1120

877-1125

SPOTCHECK® PENETRANTS

- Red visible non-destructive test method which provides for the detection of surface discontinuities (flaws) in ferrous and non-ferrous test materials
- Ideal for applications where portability is required
- Vivid red colour permits daylight inspection

MAGNAFLUX®

SKL-SP2 PENETRANTS

- Exhibits outstanding penetrating characteristics, which provide for maximum reliability in locating surface-open flaws and discontinuities
- Can be used over the entire spectrum of industrial applications, where a visible penetrant inspection system meets the requirements for surface-open flaw detection
- Has also been successfully used on non-porous ceramics and similar materials
- Not recommended for the inspection of plastic materials, as it may stain, soften or even dissolve the base material under test
- Should be used at temperatures between 40°F-125°F

Model No.	Mfg. No.	Size	Price /Each
NP701	01-5155-78	16-oz. Aerosol	57.00

SKL-WP2 WATER

WASHABLE PENETRANTS

- General purpose

Model No.	Mfg. No.	Size	Price /Each
TU436	01-5190-78	16-oz. Aerosol	57.00



SKC-S SOLVENT CLEANERS

- Non-chlorinated cleaner/remover
- Used as a pre-cleaner, a post cleaner and a penetrant remover
- Recommended general purpose
- Meets major requirements for special alloy and nuclear applications

Model No.	Mfg. No.	Size	Price /Each
NP703	01-5750-78	16-oz. Aerosol	42.00

SKD-S2 SOLVENT DEVELOPERS

- Ready-to-use suspension of white developing particles in a fast drying solvent
- Non-chlorinated solvent developer
- Meets major requirements for special alloy and nuclear applications

Model No.	Mfg. No.	Size	Price /Each
NP702	01-5352-78	16-oz. Aerosol	46.00

ARDROX®

9D1B NON-AQUEOUS DEVELOPERS

- Liquid product consisting of a finely divided white powder dispersed in a non-halogenated volatile solvent system
- Can be used with Type I (fluorescent) and Type II (visible) penetrants

906 WATER WASHABLE VISIBLE PENETRANTS

- Visible penetrants are not rated by sensitivity but are generally considered to be equivalent to Level 1
- Provides low cost, crisp indications, low residual background and temperature stability
- Used with non-aqueous developers or aqueous developers
- May be applied by aerosol, brushing, tank immersion, conventional, electrostatic or spraying

9PR50 CLEANERS/REMOVERS

- Quick drying, non-halogenated (non-chlorinated) solvent for removing oil, grease and similar soils from metal surfaces
- Provides a high level of cleaning efficiency with operational safety
- Corrosion safe for use on both ferrous and non-ferrous alloys
- Excellent penetrant remover

874-1150



Model No.	Mfg. No.	Size	Price /Each
874-1150	9D1B-16	16-oz. Aerosol	55.90

Model No.	Mfg. No.	Size	Price /Each
874-1080	906-16	16-oz. Aerosol	67.90

Model No.	Mfg. No.	Size	Price /Each
874-1180	9PR50-16	16-oz. Aerosol	38.90

WELDING & METALWORKING



SOLAR® FLUX

- Formulated to shield the back of the weld joint from oxygen, dissipate heat and unwanted oxides and to clean the surface of metal
- Will aid in the flow of filler metal over base metal and form a protective barrier to prevent re-oxidization and heat scale
- To be mixed with alcohol (methanol/methyl alcohol preferred) and brushed on the back of the weld joint
- Inert, non-flammable and non-explosive
- **Type B** for welding stainless steel and alloy steels
- **Type I** for welding high nickel super alloys



Model No.	Mfg. No.	Description	Size	Price/Each
868-1000	SFB-1	Type B	1 lb	157.00
TTT435	SFI-1	Type I	1 lb	178.00

ACID/FLUX BRUSHES

- Perfect brushes for applying liquid or paste flux



Model No.	Mfg. No.	Width"	Trim Length"	Overall Length"	Price /Each
BY189	74059	1/4	11/16	6	0.32
BY190	74060	3/8	7/8	6 1/8	0.53
BY191	74061	7/16	7/8	6 1/8	0.37
BY192	74062	9/16	7/8	6 1/8	0.64

WL941 DRY WELD SPATTER PROTECTANT

- Powder formula that dries to a white film
- Prevents spatter from sticking to metal surfaces during welding
- Just brush or wipe off residue after welding
- Does not contain silicone
- Surface may be painted after use
- Formulation does not contain Methylene Chloride
- Uses: All types of maintenance and production welding, construction and body shops



Model No.	Mfg. No.	Size	Price /Each
AE835	C00941000	15.5 oz.	13.50

WL942 WET WELD SPATTER PROTECTANT

- Keeps welding tips and nozzles clean
- Prevents weld spatter from adhering
- Non-greasy
- Effective for all types of welding, especially MIG and TIG tips
- Does not contain silicone
- Surface may be painted after use
- For contact tips, weldments, electrode holders, fixtures, resistance welding tips and wheels



Model No.	Mfg. No.	Size	Price /Each
AA875	SC0942000	15.5 oz.	14.20

E-WELD WELD SPATTER RELEASE EMULSIONS

- Effectively protects work pieces and welding equipment (such as torches, robots and jigs) eliminating costly spatter removal work
- Best for general purpose welding
- Contains temporary corrosion inhibitors
- Prevents weld spatter from sticking
- Ultrafine spray for complete coverage
- Will not harm painted surfaces
- Can be used on all weldable metals
- Green colour for a better view on work piece



Model No.	Mfg. No.	Description	Metric	Imperial	Price /Each
AA903	53-F-002	Aerosol	400 ml	13.5 fl.oz.	15.30
AC300	53-F-203	Trigger Spray	500 ml	16.9 fl.oz.	17.50
AA475	53-F-207	Liquid	20 L	5.2 gal	469.00
AC301	53-F-208	Liquid	208 L	55 gal	1759.00

E-WELD 3 WELD SPATTER RELEASE SOLUTIONS

- Unique, high performing anti-spatter solution that protects work pieces from adherence of high energy spatter and eliminates costly spatter removal operations
- Can also be used to clean and degrease surfaces prior to welding
- Formulated to prevent spatter adhesion for high temperature welding applications such as: stainless steel welding, multiple pass welding, thin sheet welding and welding pre-heated work pieces
- For MIG and Arc welding applications, as well as plasma cutting
- Water base formulation - biodegradable, non-flammable, odourless
- Compatible with aluminum, steel and stainless steel
- VOC free, solvent free and silicone free
- Contains corrosion inhibitors for short term corrosion protection
- Excellent paint adhesion properties - no special cleaning required for post welding coating operations



Model No.	Mfg. No.	Description	Metric	Imperial	Price /Each
AA506	53-F-253	Trigger Spray	500 ml	16.9 fl.oz.	19.40
AA508	53-F-257	Liquid	20 L	5.2 gal	510.00
AC309	53-F-258	Liquid	208 L	55 gal	2825.00

LPS 3[®] PREMIER RUST INHIBITOR

- Protects up to two years
- Stops rust and corrosion
- Provides non-sling lubrication
- Non-flammable propellant
- Self-healing, waxy film
- Provides anti-seize coating
- Safe to use on rubber, fabric, plastics and paints
- Meets or exceeds these specs: Boeing BMS-3 23F Type II, MIL-C-0083933A, para.3.2-3.16, MIL-C-16173D Grade 2 Class I, DMS 2150, Airbus TN A. 007.10138 Type I Grade 2
- Accepted for use in Canadian food processing facilities



Model No.	Mfg. No.	Size	Price /Each
AA808	C00316	11 oz.	36.90
AB559	C00322	20-oz. Trigger	47.50
AB558	C03128	1 gal.	169.00
AB556	C00305	5 gal.	705.00
AB557	C00355	55 gal.	5575.00

COLD GALVANISED CORROSION INHIBITOR

- 95% zinc-rich galvanized coating
- Commonly used as a flash rust preventative on welded areas
- Works like a hot-dip on ferrous metals indoors and out
- Three-year protection
- Withstands water temperature up to 212°F (100°C) and continuous dry heat up to 750°F (400°C)
- Flexible coating will not yellow, chalk, crack or peel
- Electrochemically protect bare metal
- Meets or exceeds these specs: MIL-P-46105 Weld Through Primer, Passes Preece Test for Hot-Dip Galvanizing



Model No.	Mfg. No.	Size	Price /Each
AA807	C00516	14-oz.	32.50
AB552	C05128	1 gal.	679.00

BRIGHT COAT COLD GALVANIZED CORROSION INHIBITOR

- Shiny zinc coating
- Prevents rust and corrosion on all metals
- Restores hot dip galvanizing
- Dries to touch in 15 to 30 minutes
- Repairs rusted, galvanized and welded surfaces
- Electrochemically protects bare metal
- Heat resistant, flexible coating
- Will not yellow, chalk, crack or peel



Model No.	Mfg. No.	Size	Price /Each
AB485	C05916	13 oz.	26.50

E-WELD NOZZLE ANTI-SPATTER

- Maximum Operating Temperature: 1832°F (1000°C)
- Ceramic anti-spatter that protects welding nozzles
- Provides unrivaled protection of welding nozzles in manual, semi-automated and fully-automated MIG welding applications
- Reduces downtime by extending nozzle life
- Protects welding nozzles for 8 hours
- At least 125 uses with applicator



Model No.	Mfg. No.	Size	Description	Price /Each
AF017	53F512	400 ml	-	54.80
VV928	53L121	-	Applicator	25.00
VV929	53F912	-	Aerosol & Applicator Kit	65.40

EXTEND[®] RUST TREATMENT

- Goes on white and converts rust to a durable, black, metal-protective coating in 10 minutes
- Wirebrush parts and apply with brush or spray
- Surface rust must be present
- Use as a primer or finish coat
- Resists temperatures to 250°F intermittent, 200°F continuous
- Approved by the American Bureau of Shipping



Model No.	Mfg. No.	Size	Price /Each
AA633	234981	1 qt. bottle	72.50
AA634	160802	1 gal. bottle	249.00
AC110	234984	5 gal. pail	1265.00

WL740 ZINC-RICH GALVANIZING COMPOUND

- Fast-drying, high-solids, high performance, epoxy-based coating
- Provides maximum protection to steel exposed to severe corrosive environments
- Fuses zinc to the metal substrate to protect against corrosion; equal to or better than hot-dipped galvanizing
- 97%-pure zinc dust
- May be topcoated with conventional primers or finish coats
- For fences, gutters, bridges, structural steel, wrought iron, farm equipment; ideal as a maintenance spray for highways, food plants, power plants, refineries or damaged galvanized surfaces



Model No.	Mfg. No.	Size	Price /Each
AA029	SC0740000	14 oz.	22.00

BIO-RUST NEUTRAL PH RUST REMOVER

- Removes rust and other metallic particles
- VOC free, solvent free, non-flammable, pH neutral solution biodegradable
- Not controlled under WHMIS
- Non-corrosive rust remover
- High workload - can remove 1.5 kg (3.3 lbs.) of iron oxide per 20 L
- For use with iron and mild steel
- Deeply rusted parts may require longer soaking time
- After application of Bio-Rust, rinse parts in water to remove loosened contaminants
- After removing rust, dip part into fresh bath or Bio-Rust to provide short term corrosion protection
- It is recommended to degrease part before using Bio-Rust
- Bio-Rust is designed for immersion applications only
- Immerse parts in Bio-Rust at room temperature and let react for at least 30 minutes



Model No.	Mfg. No.	Size	Price /Each	
		Litres	Gallons	
AD441	53-G 247	20	5.2	339.00
AD442	53-G248	208	55	2359.00



EL601 RED INSULATING VARNISH

- Insulating spray for general coating, impregnating and insulating electrical and electronic work
- Resists oil, water, acids and alkalis
- Excellent adhesion
- Oil resistant per ASTM-D-115-55



SP603 BLUE LAYOUT DYE

- Applies a smooth, even coat for all layout work
- Fast-drying, non-flaking, non-etching, won't peel
- Adheres to metal or glass
- For pattern-making, tool and die making, machining and maintenance mechanicals



SP606 LAYOUT DYE REMOVER

- Removes layout fluids quickly and efficiently
- Removes light oils, greases, lacquer and other markings on metal or glass
- Leaves no residue
- No chlorinated solvents
- For tool and die making and production departments



Model No.	Mfg. No.	Size	Price /Each
AA179	SC0601000	15.25 oz.	17.60

Model No.	Mfg. No.	Size	Price /Each
AA180	SC0603000	12 oz.	17.60

Model No.	Mfg. No.	Size	Price /Each
AA181	SC0606000	12.75 oz.	16.60

CUTTING OIL THREAD CUTTING LUBRICANT

- Ideal for use on all types of metals, including brass, copper and aluminum
- NSF Registered P1



A-9 ALUMINUM CUTTING FLUIDS

- Designed for aluminum, non-ferrous metals
- Forms an effective extreme pressure boundary lubricant between tool and work surface
- Leaves a surface, which requires only ordinary cleaning



RAPID TAP™ CUTTING FLUIDS

- Effective on tough-to-drill metals and alloys such as beryllium, molybdenum, stainless steel and stellite
- Makes tapping, reaming, drilling and threading operations easier, faster and more accurate
- Not recommended for use with aluminum and its alloys



Model No.	Mfg. No.	Size	Price /Each
AF250	73500	340 g	16.50

Model No.	Size	Price /Each
AA149	4 oz.	5.13

Model No.	Size	Price /Each
AA160	4 oz.	5.21

COOLCUT™

- Extends cutting tool life
- Suitable for all ferrous and non-ferrous metals
- Produces a better finish
- Solvent-free, no chlorine
- For drilling, sawing, milling, turning, reaming, broaching



ALUCUT™ ALUMINUM CUTTING LUBRICANT

- High-performance lubricant that extends cutting tool life
- Specially formulated for use with aluminum and other non-ferrous metals
- Clean, precise, stain-free application
- Ideal for inclined, vertical, and overhead surfaces
- Coats cutting edge or workpiece
- Applications include cutting with circular chopsaws, sawing with jigsaws or portable bandsaws, drilling, nibbling, and tapping



COOLCUT™ S-30 WATER-MISCIBLE CUTTING LUBRICANT

- Ready-to-use, high-performance metal cutting lubricant specially designed for automatic and semi-automatic metal removing operations
- Will not gum up slides and glides
- Increases feed, speed, and production
- Prevents bacterial growth when not in use
- Formulated with extended corrosion protection
- Contains extreme pressure additives (EP), bacterial control ingredients, and no chlorine
- Can be diluted up to 1:30



Model No.	Description	Size	Price /Each
AA468	Liquid	350 ml	21.50
AG673	Liquid	3.78 L	135.00
AA470	Liquid	20 L	559.00
AB748	Liquid	208 L	3939.00
AA471	Stick	300 g	25.90
AA467	Aerosol Spray	400 ml	34.50
AE955	Trigger Spray	500 ml	26.50

Model No.	Description	Size	Price /Each
AA191	Stick	300 g	25.50

Model No.	Description	Size	Price /Each
AG516	Jug	3.78 L	145.00
AF006	Jug	20 L	455.00
AF007	Drum	208 L	2935.00

TAPMATIC® EDGE CREME

- Excellent for vertical applications
- Biodegradable
- Can be applied to cutting tools before tapping or reaming
- For use when drilling, tapping blind holes, forming, bending, pre-coating fasteners and lubricating rubber seals
- Does not contain any hazardous chemicals
- Safe on all metals



Model No.	Mfg. No.	Size	Price /Each
AA923	C43100	11 oz.	46.90

STAINLESSCUT™ EXTREME PRESSURE CUTTING LUBRICANT

- Prolongs tool life in stainless and other tough alloys
- Produces a better finish
- Safe and pleasant to use



Model No.	Description	Size	Price /Each
AA509	Aerosol	400 ml	37.90
AA510	Squeeze Bottle	350 ml	23.90

TAPCUT™ THREAD CUTTING LUBRICANT

- Specially formulated for thread cutting with taps and dies
- Special anti-wear additives for thread cutting
- Nontoxic and biodegradable
- Produces clean, accurate threads
- Safe for use with alloys, aluminum, brass, copper, stainless steel, and steel



Model No.	Description	Size	Price /Each
AA445	Bottle	350 ml	21.50

TAPMATIC® #1 GOLD CUTTING FLUID

- Great for steel and aluminum
- Excellent for low speed, high pressure applications
- Minimizes torque increases
- No chlorinated paraffins, water, solvents or inactive fillers
- Aerosol provides a pinpoint stream with foaming action
- Safe on all metals
- Accepted for use in Canadian food processing facilities



Model No.	Mfg. No.	Size	Price /Each
AA775	C40312	11-oz. Aerosol	31.50
AA776	C40320	16 oz.	31.50
AB565	C40330	1 gal.	175.00
AB563	C40340	5 gal.	695.00

TAPMATIC® TRICUT CUTTING FLUID

- Excellent for stainless steel and other hard to machine metals
- Not recommended for aluminum
- Provides, smooth, accurate cutting action
- Flows directly to cutting edge
- Extends tool life
- Reduces friction
- Suitable for high and low speed applications
- Non-corrosive to steel



Model No.	Mfg. No.	Size	Price /Each
AA779	C05316	16 oz.	42.50
AB578	C05328	1 gal.	305.00

TAPMATIC® EDGE LUBE

- White, solid waxy bar
- Excellent for belt, wheel and disc grinding or sawing applications
- Eliminates heat build-up and belt loading
- No hazardous chemicals
- Extends grinding wheel life
- Low toxicity
- Safe on all metals
- Biodegradable



Model No.	Mfg. No.	Size	Price /Each
AA922	C43200	13 oz.	45.50

TAPMATIC® AQUACUT CUTTING FLUID

- Water-based formula
- Excellent in applications where cooling of the tool is desired
- Does not contain sulfur, chlorinated solvents, chlorine or oils
- Safe on all metals, except magnesium
- Corrosion inhibitors prevent flash rusting
- Provides fine finishes
- Cinnamon scent



Model No.	Mfg. No.	Size	Price /Each
AA778	C01216	16 oz.	26.50
AB574	C01228	1 gal.	105.00
AB572	C01205	5 gal.	539.00

TAPMATIC® NATURAL CUTTING FLUID

- Non-toxic and non-hazardous
- Biodegradable
- Does not irritate the skin, eyes or respiratory tract
- Does not contain sulfur, chlorinated solvents, chlorine water, mineral oil or inactive fillers
- Great for steel and aluminum
- High performance lubricating ability eliminates galling and seizing
- Safe on all metals



Model No.	Mfg. No.	Size	Price /Each
AA777	C44220	16 oz.	29.50
AB577	C44230	1 gal.	175.00



CANADA'S LEADING MATERIAL HANDLING SUPPLIER



FLEX™ ERGONOMIC WELDING CHAIR

- The welding flex is an ergonomic stool that reduces pressure to the lower limbs
- This product allows for multiple work position since the angle of the backrest can change between a low chair or a work bench
- Its fireproof material is ideal for welding work
- Colour: Black/Grey
- Material: Fabric
- Overall Width: 19-3/4"
- Backrest Adjustment Angle: 0° to 90°
- Casters: 3" Rubber
- Overall Depth: 14-1/2"
- Height Adjustment: Adjustable

Model No. OP427
Mfg. No. 508-00006
Price/Each \$665.00



Synetik
ErgoDesign



FLEX 2™ ERGONOMIC WELDING CHAIR

- The Flex 2 is an ergonomic stool that allow for backward work, due to its reclined backrest
- A worker can switch from a seated position to one that is declined within seconds
- Its covering is built to resist to the effect of heat and flames that can be found in welding environment
- High resilience Velva foam
- Colour: Black/Grey
- Material: Fabric
- Overall Dim.: 18-1/2" L x 16-1/2" W x 30" H
- Backrest Adjustment Angle: 0° to 85°
- Casters: 3" Rubber
- Height Adjustment: Adjustable

Model No. OP274
Mfg. No. 508-00002
Price/Each \$1139.00



Synetik
ErgoDesign

TA 180™ ERGONOMIC SIT/STAND WELDING CHAIR

- This chair is designed to improve worker well-being during tasks on elevated surfaces
- It reduces foot and leg discomfort during prolonged tasks while standing
- Height and seat angle adjustments ensure maximum user comfort
- Colour: Black/Grey
- Material: Fabric
- Overall Width: 10-1/4"
- Overall Length: 12"
- Height Adjustment: Adjustable

Model No. OP276
Mfg. No. 508-00024
Price/Each \$439.00



Synetik
ErgoDesign

STAG 4™ WELDING STOOL

- The Stag4 in suede is an ergonomic stool that reduces pressure in the knees, ankles and in the lumbar region
- Facilitates kneeling work in an absolute comfort
- Fireproof material that allows for a more secure work environment
- Colour: Black
- Material: Fabric
- Overall Width: 12-1/2"
- Casters: 3" Rubber

Model No. OP509
Mfg. No. 508-00018
Price/Each \$719.00



Synetik
ErgoDesign



TA 300™ ERGONOMIC SIT/STAND WELDING CHAIR

- The TA300 ergonomic sit/stand chair improves comfort during work in static positions or on elevated surfaces
- The backrest provides support and reduces muscular fatigue
- The wide seat and the non-slip suede band maintain stability
- Colour: Black/Grey
- Material: Fabric
- Overall Width: 12"
- Overall Length: 10-1/2"
- Height Adjustment: Adjustable

Model No. OP496
Mfg. No. 508-00030
Price/Each \$535.00



Synetik
ErgoDesign

SF 180™ MULTI-TILT ERGONOMIC WELDING CHAIR

- The ergonomic SF180 industrial chair with a larger backrest provides superior comfort when working long hours
- 3 levers allow multiple adjustments
- Suitable for many commercial environments and offices
- Allows fast and efficient movement
- Colour: Black
- Material: Fabric
- Overall Width: 19-3/4"
- Casters: 3" Rubber
- Backrest Adjustment Angle: 16° - 19°

Model No. OP275
Mfg. No. 508-00014
Price/Each \$745.00



Synetik
ErgoDesign

SF 160™ ERGONOMIC WELDING CHAIR

- The Industrial-SF160 ergonomic chair with a steel base reduces the feeling of pressure by promoting circulation and mobility
- Suitable for a wide range of industrial applications including those in manufacturing, aerospace and production
- The chair is designed for fast and efficient movement
- The larger seat provides optimal comfort
- High resilience Velva foam
- Colour: Black/Grey
- Material: Fabric
- Overall Width: 19-3/4"
- Overall Length: 16"
- Casters: 3" Rubber
- Backrest Adjustment Angle: 12° - 14°
- Height Adjustment: Adjustable

Model No. OP278
Mfg. No. 508-00012
Price/Each \$635.00



Synetik
ErgoDesign

TA 300™ ERGONOMIC SIT/STAND CHAIR

- The TA300 ergonomic sit/stand chair improves comfort during work in static positions or on elevated surfaces
- The backrest provides support and reduces muscular fatigue
- The wide seat and the non-slip suede band maintain stability
- Colour: Black
- Material: Vinyl
- Overall Width: 12"
- Overall Length: 10-1/2"

Model No. OP499
Mfg. No. 508-00029
Price/Each \$559.00

Synetik
 ErgoDesign



TF 150™ ERGONOMIC CHAIR

- The Industrial-TF150 ergonomic chair with a steel base reduces the feeling of pressure by promoting circulation and mobility
- Suitable for a wide range of industrial applications in manufacturing, aerospace and production
- The high cylinder and foot rest make it the ideal stool for work at counter height
- Colour: Black
- Material: Vinyl
- Overall Width: 12-3/4"
- Overall Length: 9"
- Casters: 3" Rubber
- Backrest Adjustment Angle: 12" - 14"

Model No. OG348
Mfg. No. 508-00031
Price/Each \$695.00

Synetik
 ErgoDesign



18-OZ. SILICA LAVASHIELD™ WELDING BLANKETS

- 18-oz. Sahara brown silica fabric
- Hemmed on all sides with Kevlar® thread that has been double-locked stitched
- Large brass grommets added for extra durability and easy handling
- Temperature Resistance: 2192°F (1200°C)

Applications: General purpose drop cloth and vertical curtain protection against extremely high temperature sparks, molten splash, welding spatter and grinding spray.



Model No.	Dimensions'	Price /Each
NT824	3 x 3	59.00
NT825	6 x 6	214.00

24-OZ. FIBREGLASS LAVASHIELD™ WELDING BLANKETS

- 24-oz. black fibreglass with neoprene coated on both sides
- Hemmed on all sides with Kevlar® thread that has been double-locked stitched
- Large brass grommets added for extra durability and easy handling
- Temperature resistance: 1000°F (538°C)

Applications: Heavy-duty vertical curtain protection against sparks, molten metal splash, welding spatter and grinding spray. General purpose drop cloth for protection against welding spatter.



Model No.	Dimensions'	Price /Each
NT896	6 x 6	78.00
NT821	6 x 8	120.00

WELD-O-GLASS WELDING BLANKETS

- 24-oz. black fibreglass, vermiculite coated
- Heavy-duty, general purpose welding blankets
- Provides protection from sparks, spatter and slag
- Temperature Resistance: 1200°F



Model No.	Mfg. No.	Dimensions'	Price /Each
146-1312	36302	6 x 6	89.70
146-1367	36318	6 x 8	112.00

30-OZ. FIBREGLASS LAVASHIELD™ WELDING BLANKETS

- 30-oz. gold fibreglass with neoprene coated on both sides
- Hemmed on all sides with Kevlar® thread that has been double-locked stitched
- Large brass grommets added for extra durability and easy handling
- Temperature Resistance: 1000°F (538°C)

Applications: Heavy-duty drop cloth and vertical curtain protection against sparks, molten metal splash, welding spatter and grinding spray.



Model No.	Dimensions'	Price /Each
NT822	6 x 6	99.00
NT823	6 x 8	144.00

WELDING & METALWORKING

COMBOFRAME ADJUSTABLE MODULAR WELDING SCREENS

FRAMES

- Innovative COMBOframe combines high durability with extreme versatility
- Made with heavy-duty finished steel tubing and connects with spring-pins
- Assembles in less than five minutes, no tools required
- Adjustable to fit both 6' and 8'-wide welding screens
- Includes 360° swivel connectors that allow various configurations

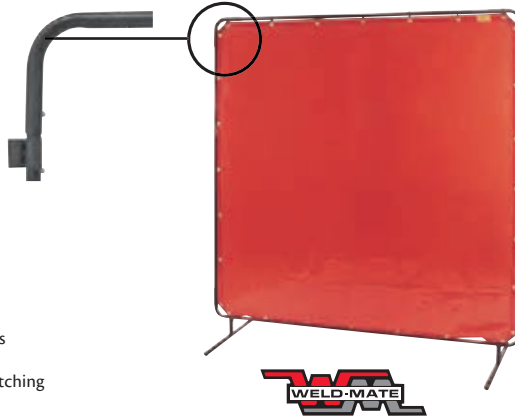

LAVASHIELD™ CURTAINS

- Specially formulated 16-mil thick vinyl
- **NT832** and **NT833**: 25-mil thick cotton duck canvas
- Grommets every 12" interval
- Screen edges are hemmed with DuPont® Kevlar® stitching
- Resists to UV rays, flame and abrasion
- **Sold per panel**

CURTAINS & FRAMES

CURTAINS ONLY

Model No.	Dimensions			Transparency	UV Resistance	Colour	Price /Each	Model No.	Price /Each
	W'	x	H'						
NT888	6	x	6	High	Moderate	Yellow	166.00	NT826	42.95
NT889	8	x	6	High	Moderate	Yellow	176.00	NT827	53.80
NT890	6	x	6	High	Moderate	Orange	166.00	NT828	42.95
NT891	8	x	6	High	Moderate	Orange	176.00	NT829	53.80
NT892	6	x	6	Moderate	Moderate	Green	166.00	NT830	42.95
NT893	8	x	6	Moderate	Moderate	Green	176.00	NT831	53.80
NT894	6	x	6	Opaque	Maximum	Olive	245.00	NT832	123.00
NT895	8	x	6	Opaque	Maximum	Olive	285.00	NT833	155.00

FRAMES ONLY

Model No.	Description	Price /Each
NT834	Modular Frame, Adjustable Width 6' or 8'	126.00

OPTIONAL CASTERS

Model No.	Description	Price /Each
SEB618*	2" Rubber Caster with Brake	6.40

*Sold individually, two casters required per frame's foot

Yellow



Orange



Green



Olive

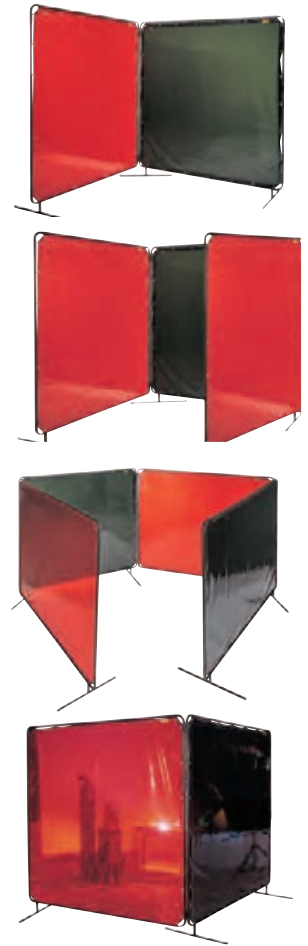

WELDSAFE® NO. 447

- Dramatically reduces fatigue while withstanding the challenges of welding environments
- Specially formulated to repel sparks and hot metal shards, the thick rubber surface has a melt point of over 500°F
- The super resilient Nitricell® sponge base is a nitrile rubber composite that offers unparalleled comfort
- All edges are safety bevelled
- 9/16" thick
- Green rating > 33% post industrial material
- Colour: Black

3-YEAR WARRANTY

Anti-fatigue mat specifically designed for welding!

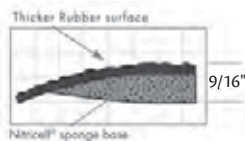

Model No.	Dimensions			Price /Each
	W'	x	L'	
NG181	2	x	3	135.00
NG182	3	x	5	339.00

See pages 380 - 391 for Welding Safety Products

WELD-ON HINGE

- Ideal for gates, machinery doors, BBQ pits, electrical boxes, trailers and more
- Can be painted to match the door and frame
- Hinges are specially buffed and are free of burrs, allowing for improved paint adherence
- Comes standard with rounded ends and with/without grease fittings
- Installation: Ensure the hinge is welded along the full length of the weld tab
- Component replacement parts are available
- Built to print solutions are available upon request
- Frame Material: Mild Steel w/Fixed Steel Pin
- Bushing Material: Brass



AURORA
TOOLS

Model No.	Length"	Diameter"	Pin Diameter"	Thickness"	Grease Fitting	Price /Each
TTV433	1.575	0.315	0.197	0.374	Not Included	1.70
TTV434	1.969	0.315	0.197	0.394	Not Included	2.20
TTV435	2.756	0.453	0.236	0.512	Not Included	3.25
TTV436	3.15	0.512	0.315	0.61	Not Included	3.35
TTV437	3.15	0.512	0.315	0.61	Included	3.70
TTV438	3.937	0.63	0.394	0.768	Included	4.95
TTV439	3.397	0.63	0.394	0.768	Not Included	4.45
TTV440	4.724	0.63	0.433	0.787	Not Included	5.45
TTV441	5.906	0.787	0.512	0.984	Included	10.25
TTV442	5.906	0.787	0.512	0.984	Not Included	9.35
TTV443	7.874	0.906	0.63	1.122	Included	16.65
TTV444	7.874	0.906	0.63	1.122	Not Included	15.20
TTV445	10.236	1.102	0.748	1.457	Not Included	24.90
TTV446	10.236	1.102	0.748	1.457	Included	21.15

ANNEALED WIRE

- Soft annealed wire offers excellent flexibility making it easier to use
- Widely used in construction and agricultural applications
- Typical agricultural applications include bailing of hay
- Black annealed wire is sometimes referred to as "burnt wire"
- Galvanized annealed wire offers the benefits of greater corrosion resistance



VANGUARD STEEL LTD.

Model No.	Wire Type	Gauge	Lbs. /Coil	Approx. Length'	Price /Each
MMS439	Black Annealed	9 ga.	50	850	177.00
MMS440	Black Annealed	12 ga.	50	1680	177.00
MMS441	Black Annealed	14 ga.	50	2900	177.00
MMS442	Black Annealed	16 ga.	50	4750	184.00
MMS443	Galvanized	9 ga.	50	850	198.00
MMS444	Galvanized	12 ga.	50	1680	198.00
MMS445	Galvanized	14 ga.	50	2900	198.00
MMS446	Galvanized	16 ga.	50	4750	219.00

REBAR TIE WIRE

- Rebar tie wire is used for binding wires
- Manufactured from soft annealed wire, which ensures the wire consistently forms the perfect tie every time
- Typical uses include bundling construction material together, securing rebar in the correct position to achieve the required strength of the complete concrete structure
- Galvanized rebar tie wire offers the benefits of greater corrosion resistance
- PVC coated tie wires offer a longer service life when compared to bright and hot dipped galvanized rebar tie wire



VANGUARD STEEL LTD.

Model No.	Wire Type	Gauge	Lbs. /Coil	Approx. Length'	Price /Each
MMS448	Black Annealed	16 ga.	3.125	340	11.00
MMS449	Galvanized	16 ga.	3.125	340	13.00
MMS450	Green PVC Coated	16 ga.	3.125	170	11.70
MMS451	Stainless Steel	16 ga.	3.125	340	61.70

SOFT TIE WIRE SPOOL

- Soft annealed wire offers excellent flexibility making it easier to use
- Ideal for equipment repair and general use
- Wire Type: Black Annealed
- Gauge: 18 ga.
- Lbs./Coil: 2 lbs.

Model No. MMS447
Price/Each \$8.73



VANGUARD STEEL LTD.

LASHING WIRE

- Grade 430 Stainless steel offers good corrosion resistance at an economical price
- Well suited for most environments
- Commonly used in the utility and telecommunication industry
- Approx. Length: 1200'
- Wire Type: Stainless Steel
- Wire Diameter: 0.045"
- Lbs./Coil: 6.62 lbs.

Model No. MMS452
Price/Each \$63.50



VANGUARD STEEL LTD.

TOOL SETS

BASIC TOOL SET

Model No. TLV075
Price/Each \$168.00

AURORA
TOOLS

SET INCLUDES:

Model No.	Description
TJZ062	1/4" Slot screwdriver
TJZ068	#2 Phillips screwdriver
TJZ073	#2 Square screwdriver
TJZ033	Hammer, 16-oz. claw
TJZ079	8" Groove joint pliers
UAV658	6" Diagonal cutting pliers
UAV660	6" Long nose pliers
TJZ092	7" Curved Jaw Locking pliers
UAV667	6.5" Long nose Locking pliers
TJZ117	16' Measuring tape
TLV083	Tool box
PE549	Utility knife
TJZ102	10" Adjustable combo Wrench
TJZ060	1/4" Stubby Slot screwdriver
TJZ069	#2 Stubby Phillips screwdriver
TJZ076	#2 Stubby Square screwdriver
TJZ075	#1 Stubby Square screwdriver



MAINTENANCE TOOL SET

Model No. TLZ459
Price/Each \$255.00

AURORA
TOOLS

SET INCLUDES:

Model No.	Description	Model No.	Description
PE549	Utility knife	TJZ102	10" Adjustable wrench
TYW991	Hacksaw frame, Heavy-duty, 12"	TJZ117	16' Measuring tape
TJZ033	16 oz. Hammer	TLV083	Tool box
TJZ043	16 oz. Rubber mallet	TJZ057	1/8" Slot screwdriver
TNB733	Imperial hex key set	TJZ061	1/4" Slot screwdriver
UAV657	10" Groove joint pliers	TJZ064	5/16" Slot screwdriver
UAV658	6" Diagonal cutting pliers	TJZ067	#1 Phillips screwdriver
UAV660	6" Long nose pliers	TJZ068	#2 Phillips screwdriver
UAV665	7" Curved jaw locking pliers	TJZ072	#1 Square screwdriver
UAV667	6.5" Long nose Locking pliers	TJZ073	#2 Square screwdriver
		TLV053	S.A.E. combo Wrench set
		SMS75	Work gloves



DELUXE TOOL SET WITH PLASTIC TOOL BOX

Model No. TYP012
Price/Each \$372.00

AURORA
TOOLS

SET INCLUDES:

Model No.	Description	Model No.	Description
TLV085	Tool box	TJZ102	Adjustable wrench, 10"
PE549	Utility knife	UAV725	Measuring tape, 1" W x 25' L, in/ft
TJZ030	Hacksaw	TJZ058	3/16" Slot screwdriver, 4"
TJZ033	Hammer, 16 oz.	TJZ060	1/4" Stubby slot screwdriver, 1 1/2"
TJZ043	Rubber mallet, 16 oz.	TJZ063	1/4" slot screwdriver, 6"
TJZ054	Hex key set, S.A.E.	TJZ067	#1 Phillips screwdriver, 3 1/4"
TJZ079	Groove joint pliers, 8"	TJZ070	#3 Phillips screwdriver, 6"
UAV655	Slip joint pliers, 6"	TJZ072	#1 Square screwdriver, 4"
UAV658	Diagonal cutting pliers, 6"	TJZ074	#3 Square screwdriver, 6"
UAV660	Long nose pliers, 6"	TLV055	S.A.E. Combo wrench set
UAV662	Linesman pliers, 7"	TJZ036	Dead blow hammer, 16 oz.
UAV665	Curved jaw locking pliers, 7"	TJZ040	Ball pein hammer, 16 oz.
UAV667	Long nose locking pliers, 6.5"	PFZ05	Replacement blades



TRADESMAN TOOL SET

Model No. TLV076
Price/Each \$480.00



SET INCLUDES:

Model No.	Description	Model No.	Description
PE812	Utility knife	TJZ061	1/4" Slot screwdriver
TYW991	Hacksaw Frame, Heavy-Duty, 12"	TJZ064	5/16" Slot screwdriver
TJZ033	Hammer, 16-oz. claw	TJZ065	3/8" Slot screwdriver
TJZ036	Dead blow Hammer 16 oz.	TJZ066	#0 Phillips screwdriver
TNB731	Hex keys, S.A.E.	TJZ067	#1 Phillips screwdriver
TNB732	Hex keys, metric	TJZ068	#2 Phillips screwdriver
UAV655	6" Split joint pliers	TJZ069	#2 Stubby Phillips screwdriver
UAV657	10" Groove joint pliers	TJZ070	#3 Phillips screwdriver
UAV659	7.5" Diagonal cutting pliers	TJZ071	#0 Square screwdriver
UAV661	8" Long nose pliers	TJZ072	#1 Square screwdriver
UAV663	8" Linesman pliers	TJZ073	#2 Square screwdriver
UAV666	10" Curved jaw locking pliers	TJZ074	#3 Square screwdriver
UAV667	6.5" Long nose Locking pliers	TJZ076	#2 Stubby Square screwdriver
TJZ102	Adjustable combo Wrench	TLV053	11-Pc. S.A.E. Wrench set
UAV725	Measuring tape, 1" W x 25' L, in/ft	TLV357	20-Pc. 3/8" S.A.E. socket set
TJZ057	1/8" Slot screwdriver	SA619	Gloves
TJZ058	3/16" Slot screwdriver	SGU581	Glasses
TJZ060	1/4" Stubby Slot screwdriver	TJZ047	Action bar
		TLV086	Tool box



PROFESSIONAL TOOL SET

Model No. TLZ460
Price/Each \$646.00



SET INCLUDES:

Model No.	Description
PE812	Utility knife
TYW991	Hacksaw Frame, Heavy-Duty, 12"
TJZ033	Hammer, 16 oz. Claw
TJZ041	Ball Pein Hammer, 24 oz.
TJZ047	13-1/2" Action bar
UAV655	6" Split joint pliers
UAV657	10" Groove joint pliers
UAV659	7.5" Diagonal cutting pliers
UAV661	8" Long nose pliers
UAV663	8" Linesman pliers
UAV666	10" Curved jaw locking pliers
UAV667	6.5" Long nose Locking pliers
TJZ102	10" Adjustable Wrench
TLV086	Tool box
UAV725	Measuring tape, 1" W x 25' L, in/ft
TLV053	S.A.E. combo Wrench set
TLV054	Metric Wrench set
TLV357	20-Pc. S.A.E. socket set
TLV358	20-Pc. metric socket set
TJZ861	Caliper
TNB731	S.A.E. hex key set
TNB732	Metric hex key set
TJZ057	1/8" Slot screwdriver
TJZ058	3/16" Slot screwdriver
TJZ060	1/4" Stubby Slot screwdriver
TJZ061	1/4" Slot screwdriver
TJZ064	5/16" Slot screwdriver
TJZ065	3/8" Slot screwdriver
TJZ066	#0 Phillips screwdriver
TJZ067	#1 Phillips screwdriver
TJZ068	#2 Phillips screwdriver
TJZ069	#2 Stubby Phillips screwdriver
TJZ070	#3 Phillips screwdriver
TJZ071	#0 Square screwdriver
TJZ072	#1 Square screwdriver
TJZ073	#2 Square screwdriver
TJZ074	#3 Square screwdriver
TJZ076	#2 Stubby Square screwdriver
SAJ023	Work gloves
SGU581	Glasses



TOOL SETS

INTERMEDIATE TOOL SET WITH STEEL CHEST

Model No. TLV422
Price/Each \$1210.00



AURORA
TOOLS

SET INCLUDES:

Model No.	Description
TER065	Industrial tool cart, 7 drawers
TJZ057	Screwdriver, Slot cabinet, 1/8" Tip, 3" Shank
TJZ058	Screwdriver, Slot cabinet, 3/16" Tip, 4" Shank
TJZ060	Screwdriver, Slot mechanics, 1/4" Tip, 1 1/2" Stubby shank
TJZ061	Screwdriver, Slot mechanics, 1/4" Tip, 4" Shank
TJZ064	Screwdriver, Slot mechanics, 5/16" Tip, 6" Shank
TJZ065	Screwdriver, Slot mechanics, 3/8" Tip, 8" Shank
TJZ066	Screwdriver, Phillips, #0 Tip, 2 1/2" Shank
TJZ067	Screwdriver, Phillips, #1 Tip, 3 1/4" Shank
TJZ068	Screwdriver, Phillips, #2 Tip, 4" Shank
TJZ069	Screwdriver, Phillips, #2 Tip, 1 1/2" Stubby shank
TJZ070	Screwdriver, Phillips, #3 Tip, 6" Shank
TJZ071	Screwdriver, Square, #0 Tip, 4" Shank
TJZ072	Screwdriver, Square, #1 Tip, 4" Shank
TJZ073	Screwdriver, Square, #2 Tip, 6" Shank
TJZ074	Screwdriver, Square, #3 Tip, 6" Shank
TJZ076	Screwdriver, Square, #2 Tip, 1 1/2" Stubby shank
UAV655	Plier, Slip joint, 6" L
TJZ079	Plier, Groove joint, 8" L
UAV658	Plier, Diagonal cutting, 6" L
UAV659	Plier, Diagonal cutting, 7.5" L
UAV660	Plier, Long nose cutting, 6" L
UAV661	Plier, Long nose cutting, 8" L
UAV663	Plier, Linesman Cutting, 8" L
TJZ091	Locking plier, Curved jaw w/ wire cutter, 5" L

Model No.	Description
UAV666	Locking plier, Curved jaw w/ wire cutter, 10" L
UAV667	Locking plier, Long nose w/ wire cutter, 6.5" L
UAV668	Locking plier, C-Clamps w/ Swivel Pads, 11" L
TJZ100	Wrench, Adjustable, 6", w/ Composite grip
TJZ103	Wrench, Adjustable, 12", w/ Composite grip
TLV053	Aurora 11-Pc. S.A.E. Wrench Set with pouch
TLV054	Aurora 11-Pc. Metric Wrench Set with pouch
TLV360	Socket Set, 41-Pc., 1/4" & 3/8" Drive S.A.E./Metric
TLZ396	Cold chisel, 5/16" x 5" L
TLZ398	Cold chisel, 1/2" x 6" L
TLZ400	Cold chisel, 3/4" x 7" L
TLZ417	Centre punch, 5/32" x 5" L
TLZ415	Centre punch, 5/64" x 3 1/2" L
TLZ419	Centre punch, 3/8" x 6 1/4" L
TLZ402	Pin punch, 3/32" x 4 1/2" L
TLZ405	Pin punch, 3/16" x 5 1/4" L
TLZ403	Pin punch, 1/8" x 4 3/4" L
TYW991	Hacksaw Frame, Heavy-Duty, 12"
TJZ047	Action bar, 1 3/8" x 1/4" x 13 1/2"
PE812	Utility knife, H-D, w/ auto reload, Snap-off blades
TJZ033	Hammer, Hickory handle, 16-oz., Claw
TJZ036	Hammer, Dead blow, 16-oz.
TJZ038	Hammer, Dead blow, 32-oz.
TJZ040	Hammer, Ball Peen, 16-oz.
TJZ042	Hammer, Ball Peen, 32-oz.
TNB731	Hex keys, S.A.E. Short arm, 13 Keys, 0.050" - 3/8"
UAV725	Measuring tape, HD, 1" W x 25' L, in/ft



ESSENTIAL TOOL SET WITH PLASTIC TOOL BOX

Model No. TYP013
Price/Each \$216.00

AURORA
TOOLS

SET INCLUDES:

Model No.	Description	Model No.	Description
TLV084	Tool Chest	UAV658	Diagonal cutting pliers, 6"
TJZ072	#1 Square screwdriver, 4"	UAV660	Long nose pliers, 6"
TJZ073	#2 Square screwdriver, 6"	TJZ091	Locking pliers, 5"
TJZ067	#1 Phillips screwdriver, 3 1/4"	UAV667	Long nose locking pliers, 6.5"
TJZ068	#2 Phillips screwdriver, 4"	TJZ101	Adjustable wrench, 8"
TJZ062	1/4" Slot screwdriver, 5"	TJZ033	Hammer, 16 oz.
TJZ064	5/16" Slot screwdriver, 6"	PE549	Utility knife
TJZ054	Hex key set, S.A.E.	TJZ036	Dead blow hammer, 16 oz.
UAV725	Measuring tape, 1" W x 25' L, in/ft	TJZ040	Ball peen hammer, 16 oz.
UAV655	Slip joint pliers, 6"	TJZ043	Rubber mallet, 16 oz.



MECHANIC'S TOOL SET & STORAGE

- Comprehensive 873 piece set mix of mechanics hand tools including drive tools, sockets, bit sockets, impact sockets, ratcheting wrenches, combination wrenches, pliers, screwdriver, Bolt Biter™ extraction tools, and more
- 90-tooth ratchet gear delivers a 4° swing arc to turn a fastener in tight confines
- 72-tooth ratcheting wrenches with a 5° swing arc with off-corner loading design on box end provides better grip and reduces fastener rounding
- Bolt Biter™ extraction products offer a bi-directional design and for removing or tightening rounded and damaged fasteners
- Chrome and impact sockets and drive tools in 1/4", 3/8", & 1/2" drive in commonly used SAE and metric sizes
- Dual material handle Phillips®, slotted, and Torx® standard and precision screwdrivers included
- Precision engineered bit sockets with bits made of S2 steel for added strength and better fastener fit
- Professional assortment of ergonomic dual material handle pliers with tongue and groove, slip joint, linesman's, diagonal cutting, and long nose
- 41" 11 drawer GSX rolling tool cabinet features a heavy-gauge stainless steel worktop and a built-in charging station
- Set ships in 3 pallets with tools pre-packed in premium foam storage trays
- Full lifetime warranty on all hand tools with a 3 year warranty on tool storage
- No. of Pieces: 873
- Finish: Full Polish Chrome
- Drive Type: 6 & 12 Point
- Manufacturer's Warranty: Lifetime Warranty on Hand Tools, 3-Year Warranty on Tool Storage



Model No. UAX355
Mfg. No. MEGAMOD873
Price/Each \$8702.80

GW GEARWRENCH

MECHANIC'S TOOL SET & STORAGE

- Comprehensive 791 piece set mix of mechanics hand tools including drive tools, sockets, combination wrenches, and hex keys
- 90-tooth ratchet gear delivers a 4° swing arc to turn a fastener in tight confines
- Full polish chrome 6 point combination wrenches are designed for a secure fit on hex fasteners
- Bolt Biter™ extraction products offer a bi-directional design and for removing or tightening rounded and damaged fasteners
- Sockets and drive tools in 1/4", 3/8", & 1/2" drive in commonly used SAE and metric sizes
- Precision engineered bits are made of S2 steel for added strength and better fastener fit
- 26" GSX top chest and rolling cart offer 9 drawers and top compartment of storage space
- Foam storage trays include size markings for optimal organization
- Set ships in 2 pallets, with tools pre-packed in premium foam storage trays
- Full lifetime warranty on all hand tools with a 3 year warranty on tool storage
- No. of Pieces: 791
- Finish: Full Polish Chrome
- Drive Type: 6 & 12 Point
- Manufacturer's Warranty: Lifetime Warranty on Hand Tools, 3-Year Warranty on Tool Storage



GW GEARWRENCH

Model No. UAX356
Mfg. No. MEGAMODPRO
Price/Each \$6353.10

MASTER MECHANIC'S HAND TOOL SET & MOBILE WORK STATION

- Comprehensive 614 piece set mix of mechanics hand tools including drive tools, sockets, bit sockets, wrenches, ratcheting wrenches, pliers and screwdrivers
- 90-tooth ratchet gear delivers a 4° swing arc to turn a fastener in tight confines
- 72-tooth ratcheting wrenches with a 5° swing arc with off-corner loading design on box end provides better grip and reduces fastener rounding
- Flex head ratcheting wrenches with flex head that tilts up to 180 degrees at any interval
- Reversible ratcheting wrenches with compact reversing lever allows for quick changes without removing ratcheting box end from fastener
- Tri-lobe ergonomic dual material handle Phillips and slotted screwdrivers for optimal balance of strength and comfort
- Precision engineered hex and ball-end hex bit sockets with bits made of S2 steel for added strength and better fastener fit
- Professional assortment of ergonomic dipped grip handle pliers with tongue and groove, slip joint, linesman's, diagonal cutting, and long nose
- 42" 11 drawer GSX mobile work station offers 19,000 cubic inches of storage capacity and a built-in charging station
- Tools pre-packed in foam storage trays
- Full lifetime warranty on all hand tools and a 5 year warranty on the mobile workstation
- No. of Pieces: 614
- Finish: Full Polish Chrome
- Drive Type: 6 & 12 Point
- Manufacturer's Warranty: Lifetime Warranty on Hand Tools, 5-Year Warranty on Mobile Work Station



Model No. UAX357
Mfg. No. MEGAMODMRO
Price/Each \$6175.30

GW GEARWRENCH

SOCKET SETS

MECHANICS TOOL SET IN 3 DRAWER STORAGE BOX

- Full polish chrome SAE and metric 1/4", 3/8" and 1/2" standard sockets, and 1/4" and 3/8" deep sockets
- 45-tooth quick release full polish chrome teardrop ratchets, with flush-mounted on/off lever
- Contains 12 point full polish long pattern combination wrenches and sockets
- Extension bars feature a knurled grip, providing a non slip surface
- Sockets and wrenches feature off corner loading technology to reduce fastener rounding
- Full polish chrome makes clean-up easy
- 3-drawer storage box with independent sliding drawers, locking side flaps, a steel hinged lid and a durable handle
- Combination wrenches feature a 15° offset box end for added knuckle clearance
- SAE and metric long arm hex keys
- Magnetic bit driver with 9 bits including torn, slotted and Phillips®
- Meets or exceeds ASME specifications
- Packaging is recyclable
- No. of Pieces: 239
- **Includes:**
 - 5/32"-9/16" & 4mm-15mm 1/4" Drive Standard Sockets
 - 3/16"-9/16" & 4mm-14mm 1/4" Drive Deep Sockets
 - 7/32"-13/16" & 6mm-22mm 3/8" Drive 6-Point Standard Sockets
 - 3/8"-3/4" & 9mm-19mm 3/8" Drive Deep Sockets
 - 1/4"-7/8" & 6mm-22mm 3/8" Drive 12 Point Standard Sockets
 - 7/16"-1-1/2" & 15mm-27mm 1/2" Drive Standard Sockets
 - 1/4" Drive 45-Tooth Quick Release Teardrop Ratchet 5-1/2"
 - 3/8" Drive 45-Tooth Quick Release Teardrop Ratchet 7-3/4"
 - 1/2" Drive 45-Tooth Quick Release Teardrop Ratchet 9-1/2"
 - 2", 3" & 6" Long 1/4" Drive Extensions
 - 3" & 6" Long 3/8" Drive Extensions, 3" & 5" 1/2" Drive Extensions
 - 1/4"-3/4" & 6mm-19mm 12 Point Long Pattern Combination Wrenches
 - 5/8" & 13/16" 3/8" Drive 6 Point 2-1/2" Spark Plug Sockets
 - 1/4" Magnetic Bit-Holding Screwdriver Handle



Model No. AUW197
Mfg. No. 80942
Price/Each \$484.00



RATCHET & SOCKET SET WITH PACKOUT™ LOW-PROFILE ORGANIZER

- Sockets with Four Flat™ Sides on socket deter rolling
- Ratchet has 90 tooth design with 4-degree arc swing for tight work spaces
- Ratchet has a flush directional lever
- Packout™ Organizer has an impact resistant body
- Packout™ organizer has clear top for easy identification of contents
- Packout™ organizer has reinforced hinge
- Four Flat™ Sides feature wrench-ready design
- Ratchet and socket set with slim profile ratchet
- Sockets with stamped sizes
- Packout™ Organizer has a IP65 Rated Protection
- Packout™ organizer has heavy-duty latches
- Drive Size: 1/4", 3/8"
- No. of Pieces: 106

Model No. TER124
Mfg. No. 48-22-9486
Price/Each \$359.00



SOCKET SETS

- Chrome vanadium steel for extra strength and durability
- Ratchet with contoured handle for comfort and added torque
- Chrome-plated sockets to resist rust
- 6-point sockets for a snug fit
- Laser-marked socket size on each socket for easy identification



22-PC. 1/4" DRIVE S.A.E. SOCKET SETS

SET INCLUDES:

- 9 standard sockets:** 3/16", 7/32", 1/4", 9/32", 5/16", 11/32", 3/8", 7/16", 1/2"
- 7 deep sockets:** 1/4", 9/32", 5/16", 11/32", 3/8", 7/16", 1/2"
- 6 accessories:** Quick release ratchet
Extensions: 2" and 6"
Universal joint
Drive palm ratchet
Plastic handle driver

Model No. TLV356
Price/Each \$56.15



20-PC. 3/8" DRIVE S.A.E. SOCKET SETS

SET INCLUDES:

- 9 standard sockets:** 3/8", 7/16", 1/2", 9/16", 5/8", 11/16", 3/4", 13/16", 7/8"
- 8 deep sockets:** 3/8", 7/16", 1/2", 9/16", 5/8", 11/16", 3/4", 13/16"
- 3 accessories:** Quick release ratchet
Extensions: 2" and 3"

Model No. TLV357
Price/Each \$62.75



24-PC. 3/8" DRIVE METRIC SOCKET SETS

SET INCLUDES:

- 13 standard sockets:** 7, 8, 9, 10, 11, 12, 13, 14, 15, 16, 17, 18, 19 mm
- 8 deep sockets:** 10, 11, 12, 13, 14, 15, 17, 19 mm
- 3 accessories:** Spark plug socket 16 mm
Ratchet
3" extension

Model No. TLV358
Price/Each \$64.95



29-PC. 1/2" DRIVE S.A.E./METRIC SOCKET SETS

SET INCLUDES:

- 24 standard sockets:** 3/8", 7/16", 1/2", 9/16", 5/8", 11/16", 3/4", 13/16", 7/8", 15/16", 1", 9, 10, 11, 12, 13, 14, 15, 16, 17, 18, 19, 20, 21 mm
- 5 accessories:** Quick release ratchet
Extensions: 5" and 10"
Universal joint
3/8" drive adapter
(3/8" F x 1/2" M)

Model No. TLV359
Price/Each \$98.95



41-PC. 1/4" & 3/8" DRIVE S.A.E./METRIC SOCKET SETS

- Chrome vanadium steel for extra strength and durability
- Ratchet with contoured handle for comfort and added torque
- Chrome-plated sockets to resist rust
- 6-point sockets for a snug fit
- Laser-marked socket size on each socket for easy identification

AURORA
TOOLS



SET INCLUDES:

- 19 1/4" standard sockets:** 3/16", 7/32", 1/4", 9/32", 5/16", 11/32", 3/8", 7/16", 1/2"
4, 4.5, 5, 6, 7, 8, 9, 10, 11, 12 mm
- 16 3/8" standard sockets:** 3/8", 7/16", 1/2", 9/16", 5/8", 11/16", 3/4", 13/16"
10, 11, 12, 13, 14, 15, 17, 19 mm
- 6 accessories:** Quick release ratchet 3/8" drive
Extensions 3/8" drive: 3" and 6"
Universal joint 3/8" drive
3/8" drive adapter (3/8" F x 1/4" M)
Plastic handle driver 1/4"

Model No. TLV360
Price/Each \$90.45

120-PC. 1/4", 3/8" & 1/2" DRIVE S.A.E./METRIC SOCKET & WRENCH SETS

AURORA
TOOLS



SET INCLUDES:

- 20 1/4" standard sockets:** 5/32", 3/16", 7/32", 1/4", 9/32", 5/16", 11/32", 3/8", 7/16", 1/2"
4, 5, 6, 7, 8, 9, 10, 11, 12, 13 mm
- 18 3/8" standard sockets:** 3/8", 7/16", 1/2", 9/16", 5/8", 11/16", 3/4"
9, 10, 11, 12, 13, 14, 15, 16, 17, 18, 19 mm
- 13 1/2" standard sockets:** 13/16", 7/8", 15/16", 1", 1 1/16", 1 1/4"
20, 21, 22, 24, 27, 30, 32 mm
- 4 1/4" deep sockets:** 8, 9, 10, 11 mm
- 4 3/8" deep sockets:** 13, 14, 15, 17 mm
- 8 3/8" Torx sockets:** E8, E10, E11, E12, E14, E16, E18, E20
17, 19, 21, 24 mm
- 4 1/2" impact sockets:** T10, T15, T20, T25, T27, T30, T40
- 7 1/4" Torx bits:** Torx: T20, T30, T40, T45, T50, T55, T60
Hex: 3, 4, 5, 6 mm
Phillips: #1, #2
Slotted: 5.5, 6.5 mm
Pozi driv: #1, #2
- 25 accessories:** Quick release ratchet 1/4", 3/8" and 1/2"
Spark plug socket 3/8" drive: 16, 21 mm
Universal joint 1/4", 3/8", 1/2"
Extension 1/4" drive: 2"
Extension 3/8" drive: 3" and 6"
Extension 1/2" drive: 5" and 10"
Plastic handle driver 1/4" drive
Bit adapter 1/4" drive
Combination wrench: 8, 9, 10, 11, 12, 13, 14, 17, 18, 19 mm

Model No. TLV361
Price/Each \$270.00

210-PC. 1/4", 3/8" & 1/2" DRIVE S.A.E./METRIC SOCKET & WRENCH SETS

- Chrome vanadium steel for extra strength and durability
- Ratchet with contoured handle for comfort and added torque
- Chrome-plated sockets to resist rust
- 6-point sockets for a snug fit
- Laser-marked socket size on each socket for easy identification

AURORA
TOOLS



SET INCLUDES:

- 24 1/4" standard sockets:** 5/32", 3/16", 7/32", 1/4", 9/32", 5/16", 11/32", 3/8", 7/16", 1/2", 9/16"
4, 4.5, 5, 6, 6.5, 7, 8, 9, 10, 11, 12, 13, 14 mm
- 25 3/8" standard sockets:** 1/4", 9/32", 5/16", 11/32", 3/8", 7/16", 1/2", 9/16", 5/8", 11/16", 3/4"
6, 7, 8, 9, 10, 11, 12, 13, 14, 15, 16, 17, 18, 19 mm
- 27 1/2" standard sockets:** 5/16", 3/8", 7/16", 1/2", 9/16", 5/8", 11/16", 3/4", 7/8", 1"
8, 9, 10, 11, 12, 13, 14, 15, 16, 17, 18, 19, 20, 21, 22, 23, 24 mm
- 15 1/4" deep sockets:** 1/4", 5/16", 3/8", 7/16", 1/2", 9/16"
6, 7, 8, 9, 10, 11, 12, 13, 14 mm
- 20 3/8" deep sockets:** 5/16", 3/8", 7/16", 1/2", 9/16", 5/8", 11/16", 3/4"
8, 9, 10, 11, 12, 13, 14, 15, 16, 17, 18, 19 mm
- 21 1/2" deep sockets:** 5/16", 3/8", 7/16", 1/2", 5/8", 9/16", 11/16", 3/4", 13/16", 7/8"
10, 11, 12, 13, 14, 16, 17, 19, 20, 21, 22 mm
- 30 1/4" shank bits:** Phillips: #0, #1, #2, #3
Slotted: 3, 4, 5, 6, 7, 8 mm
Pozi driv: #0, #1, #2, #3
Hex: 2, 3, 4, 5, 6, 8 mm
Torx: T8, T10, T15, T20, T25, T27, T30
Square: #1, #2, #3
- 12 8 mm shank bits:** Phillips: #3, #4
Pozi driv: #3, #4
Hex: 8, 10, 12, 14 mm
Torx: T40, T45, T50, T55
- 36 accessories:** Quick release ratchet 1/4", 3/8" and 1/2"
Spark plug socket 1/2" drive: 16, 21 mm
Universal joint 1/4", 3/8", 1/2"
Extension 1/4" drive: 2" and 4"
Extension 3/8" drive: 3" and 6"
Extension 1/2" drive: 5" and 10"
Plastic handle driver 1/4" drive
Sliding T-bar: 1/4" and 3/8"
3-Way adapter (3/8" F x 1/2" M)
Bit adapter 1/4" drive
Bit adapter 1/2" drive
Combination wrench:
5/16", 3/8", 7/16", 1/2", 9/16", 5/8", 11/16", 3/4"
8, 10, 11, 13, 14, 16, 18, 19 mm

Model No. TLV362
Price/Each \$435.00

SOCKET SETS

1/2" DRIVE 6-POINT DEEP METRIC IMPACT SOCKET SET

- Sockets made of the finest quality S.A.E. 4140 Chrome Molybdenum high-impact steel
- Torque Drive® socket design contacts the fastener on the sides instead of the corners, reducing fastener rounding and allowing up to 20% more torque
- Chamfered edges allow easiest socket placement on fastener, increasing productivity and reducing frustration
- Extra long deep sockets ensure maximum accessibility
- Encased in a blow mould case with removable lid
- No. of Pieces: 22
- Includes: 10 mm, 11 mm, 12 mm, 13 mm, 14 mm, 15 mm, 16 mm, 17 mm, 18 mm, 19 mm, 20 mm, 21 mm, 22 mm, 23 mm, 24 mm, 25 mm, 26 mm, 27 mm, 28 mm, 29 mm, 30 mm, 32 mm
- Standard(s) Met: ANSI, GGG-W-660A

Model No. AUW040
Mfg. No. 610339
Price/Each \$315.00



1/2" DRIVE 6-POINT METRIC IMPACT SOCKET SET

- Sockets made of the finest quality S.A.E. 4140 Chrome Molybdenum high-impact steel
- Torque Drive® socket design contacts the fastener on the sides instead of the corners, reducing fastener rounding and allowing up to 20% more torque
- Chamfered edges allow easiest socket placement on fastener, increasing productivity and reducing frustration
- Extra long deep sockets ensure maximum accessibility
- Encased in a blow mould case with removable lid
- No. of Pieces: 22
- Includes: 10 mm, 11 mm, 12 mm, 13 mm, 14 mm, 15 mm, 16 mm, 17 mm, 18 mm, 19 mm, 20 mm, 21 mm, 22 mm, 23 mm, 24 mm, 25 mm, 26 mm, 27 mm, 28 mm, 29 mm, 30 mm, 32 mm
- Standard(s) Met: ANSI, GGG-W-660A

Model No. AUW039
Mfg. No. 610338
Price/Each \$197.00



1/2" DRIVE METRIC BALL NOSE HEX IMPACT SOCKET SET

- Modern design brings ball nose flexibility to impact hex socket use
- Allows angled entry to fasteners in restricted areas, increasing productivity
- Features S.A.E. 4140 Chrome Molybdenum bits for demanding professional applications
- Large laser markings for easy socket identification
- Encased in a tough blow mould case with removable lid for use as a tool drawer organizer
- No. of Pieces: 9
- Drive: 1/2"
- Includes: 6 mm, 7 mm, 8 mm, 10 mm, 12 mm, 14 mm, 15 mm, 17 mm, 19 mm (Bits)
- Type: Impact Sockets

Model No. AUW038
Mfg. No. 610336
Price/Each \$127.00



1/2" DRIVE SAE 6-POINT IMPACT SOCKET SET

- The sockets are made of the finest quality S.A.E. 4140 Chrome Molybdenum high-impact steel
- Torque Drive® socket design contacts the fastener on the sides instead of the corners, reducing fastener rounding and allowing up to 20% more torque
- Chamfered edges allow easiest socket placement on fastener, increasing productivity and reducing frustration
- Extra long deep sockets ensure maximum accessibility
- Encased in a blow mould case with removable lid
- No. of Pieces: 19
- Includes: 3/8", 7/16", 1/2", 9/16", 5/8", 11/16", 3/4", 13/16", 7/8", 15/16", 1", 1-1/16", 1-1/8", 1-3/16", 1-1/4", 1-5/16", 1-3/8", 1-7/16", 1-1/2"

Model No. AUW036
Mfg. No. 610328
Price/Each \$191.00



1/2" DRIVE SAE BALL NOSE HEX IMPACT SOCKET SET

- Modern design brings ball nose flexibility to impact hex socket use
- Allows angled entry to fasteners in restricted areas
- Features large laser markings for easy socket identification
- Encased in a tough blow mould case with removable lid for use as a tool drawer organizer
- No. of Pieces: 9
- Finish: Black Phosphate
- Material: Chrome Molybdenum
- Includes: 1/2", 1/4", 11/16", 3/4", 3/8", 5/16", 5/8", 7/16", 9/16"
- Socket Bit Type: Hex, Ball Nose
- Socket Depth: Standard
- Socket Type: Impact
- Drive: 1/2"
- Standard(s) Met: ANSI, GGG-W-660A
- Socket Bit Length: Long

Model No. AUW037
Mfg. No. 610332
Price/Each \$127.00



1/2" DRIVE TORX® BIT IMPACT SOCKET SET

- Made of SNCM 8660 tool steel for 20% greater torque and 20% greater torsional resistance than regular Chrome Molybdenum bits
- Features a blow mould case
- No. of Pieces: 10
- Finish: Manganese Phosphate
- Overall Length: 3"
- Includes: T25, T27, T30, T40, T45, T50, T55, T60, T70, T80

Model No. AUW035
Mfg. No. 610326
Price/Each \$150.00



SHOCKWAVE IMPACT DUTY™ PACKOUT™ 1/2" DRIVE METRIC DEEP SOCKET SET

- Optimized for use with 1/2" drive impact wrenches, drivers, ratchets, and adapters
- Set comes in Packout™ Organizer
- Stamped and ink filled diameter markings for wear resistance
- 6-Point design made with forged impact steel for durability in high torque applications
- Dual hole design and groove for easier attachment
- Non-slip hex geometry to prevent socket and fastener rounding
- Milwaukee's Lifetime Guarantee covers impact sockets and extensions only
- Sets can be kept organized in the included MILWAUKEE® Packout™ Compact Low-Profile Organizer with a clear top for easy identification of parts at a glance
- Meets ASME Industry Standards
- Includes: 10mm, 11mm, 12mm, 13mm, 14mm, 15mm, 16mm, 17mm, 18mm, 19mm, 20mm, 21mm, 22mm, 23mm, 24mm Deep metric sockets, 3" Extension
- No. of Pieces: 16
- **Manufacturer's Warranty:**
Lifetime Warranty

Model No. UAV595
Mfg. No. 49-66-6803
Price/Each \$200.00



SHOCKWAVE IMPACT DUTY™ PACKOUT™ 1/2" DRIVE DEEP SOCKET SET

- Optimized for use with 1/2" drive impact wrenches, drivers, ratchets, and adapters
- Set comes in Packout™ Organizer
- Stamped and ink filled diameter markings for wear resistance
- 6-Point design made with forged impact steel for durability in high torque applications
- Dual hole design and groove for easier attachment
- Non-slip hex geometry to prevent socket and fastener rounding
- Milwaukee's Lifetime Guarantee covers impact sockets and extensions only
- Sets can be kept organized in the included MILWAUKEE® Packout™ Compact Low-Profile Organizer with a clear top for easy identification of parts at a glance
- Meets ASME Industry Standards
- Includes: 3/8", 7/16", 1/2", 9/16", 5/8", 11/16", 3/4", 13/16", 7/8", 15/16", 1", 1-1/16", 1-1/8", 1-1/4", 1-1/2", 10mm, 11mm, 12mm, 13mm, 14mm, 15mm, 16mm, 17mm, 18mm, 19mm, 20mm, 21mm, 22mm, 23mm, 24mm Deep sockets, 3" Extension
- No. of Pieces: 31
- **Manufacturer's Warranty:**
Lifetime Warranty

Model No. UAV598
Mfg. No. 49-66-6806
Price/Each \$362.00



SHOCKWAVE IMPACT DUTY™ PACKOUT™ 1/2" DRIVE SAE DEEP SOCKET SET

- Optimized for use with 1/2" drive impact wrenches, drivers, ratchets, and adapters
- Tray compatible with PACKOUT™ Organizers (48-22-8435) and (48-22-8430) and fit in tool chest drawers
- Stamped and ink filled diameter markings for wear resistance
- 6-Point design made with forged impact steel for durability in high torque applications
- Dual hole design and groove for easier attachment
- Non-slip hex geometry to prevent socket and fastener rounding
- Milwaukee's Lifetime Guarantee covers impact sockets and extensions only
- Meets ASME Industry Standards
- Laser-etched part numbers
- Includes: 3/8", 7/16" 1/2, 9/16, 5/8, 11/16, 3/4, 13/16, 7/8, 15/16, 1", 1-1/16", 1-1/8", 1-1/4", 1-1/2" Deep sockets
- No. of Pieces: 15
- **Manufacturer's Warranty:**
Lifetime Warranty

Model No. UAV601
Mfg. No. 49-66-6817
Price/Each \$165.00



SHOCKWAVE IMPACT DUTY™ PACKOUT™ 1/2" DRIVE DEEP SOCKET SET

- Optimized for use with 1/2" drive impact wrenches, drivers, ratchets, and adapters
- Tray compatible with PACKOUT™ Organizers (48-22-8435) and (48-22-8430) and fit in tool chest drawers
- Stamped and ink filled diameter markings for wear resistance
- 6-Point design made with forged impact steel for durability in high torque applications
- Dual hole design and groove for easier attachment
- Non-slip hex geometry to prevent socket and fastener rounding
- Milwaukee's Lifetime Guarantee covers impact sockets and extensions only
- Meets ASME Industry Standards
- Laser-etched part numbers
- Includes: 10mm, 11mm, 12mm, 13mm, 14mm, 15mm, 16mm, 17mm, 18mm, 19mm, 20mm, 21mm, 22mm, 23mm, 24mm, Deep sockets, 3" Extension
- No. of Pieces: 16
- **Manufacturer's Warranty:**
Lifetime Warranty

Model No. UAV602
Mfg. No. 49-66-6818
Price/Each \$165.00



SHOCKWAVE IMPACT DUTY™ PACKOUT™ 1/2" DRIVE METRIC STANDARD SOCKET SET

- Optimized for use with 1/2" drive impact wrenches, drivers, ratchets, and adapters
- Set comes in Packout™ Organizer
- Stamped and ink filled diameter markings for wear resistance
- 6-Point design made with forged impact steel for durability in high torque applications
- Dual hole design and groove for easier attachment
- Non-slip hex geometry to prevent socket and fastener rounding
- Milwaukee's Lifetime Guarantee covers impact sockets and extensions only
- Sets can be kept organized in the included MILWAUKEE® Packout™ Compact Low-Profile Organizer with a clear top for easy identification of parts at a glance
- Meets ASME Industry Standards
- Includes: 10mm, 11mm, 12mm, 13mm, 14mm, 15mm, 16mm, 17mm, 18mm, 19mm, 20mm, 21mm, 22mm, 24mm, 3/8", 7/16", 1/2", 9/16", 5/8", 11/16", 3/4", 13/16", 7/8", 15/16", 1", 1-1/16", 1-1/8" Standard sockets
- No. of Pieces: 27
- **Manufacturer's Warranty:**
Lifetime Warranty

Model No. UAV596
Mfg. No. 49-66-6804
Price/Each \$200.00



13-PIECE SAE 12-POINT DEEP SOCKET SET

- All components forged from high quality Chrome Vanadium steel
 - Torque Drive® sockets contact the fastener on the sides rather than the corners, reducing corner rounding and allowing 20% more torque
 - Chamfered edges allow easiest socket placement on fastener, increasing productivity and reducing frustration
 - Extra long deep sockets ensure maximum accessibility
 - Drive Size: 1/2"
 - Includes: 7/16, 1/2, 9/16, 5/8, 11/16, 3/4, 13/16, 7/8, 15/16, 1, 1-1/16, 1-1/8, 1-1/4", Socket rail
- Model No. AUW033
Mfg. No. 601318
Price/Each \$178.00



SOCKET SETS

SHOCKWAVE IMPACT DUTY™ PACKOUT™ 1/2" DRIVE SAE DEEP SOCKET SET

- Optimized for use with 1/2" drive impact wrenches, drivers, ratchets, and adapters
 - Set comes in Packout™ Organizer
 - Stamped and ink filled diameter markings for wear resistance
 - 6-Point design made with forged impact steel for durability in high torque applications
 - Dual hole design and groove for easier attachment
 - Non-slip hex geometry to prevent socket and fastener rounding
 - Sets can be kept organized in the included MILWAUKEE® Packout™ Compact Low-Profile Organizer with a clear top for easy identification of parts at a glance
 - Meets ASME Industry Standards
 - Includes: 3/8", 7/16", 1/2", 9/16", 5/8", 11/16", 3/4", 13/16", 7/8", 15/16", 1", 1-1/16", 1-1/8", 1-1/4", 1-1/2" Deep SAE sockets
 - No. of Pieces: 15
 - **Manufacturer's Warranty:**
Lifetime Warranty
- Model No. UAV594**
Mfg. No. 49-66-6802
Price/Each \$200.00

Milwaukee



SHOCKWAVE IMPACT DUTY™ PACKOUT™ 1/2" DRIVE STANDARD SOCKET SET

- Optimized for use with 1/2" drive impact wrenches, drivers, ratchets, and adapters
 - Tray compatible with Packout™ Organizers (48-22-8435) and fit in tool chest drawers
 - Stamped and ink filled diameter markings for wear resistance
 - 6-Point design made with forged impact steel for durability in high torque applications
 - Dual hole design and groove for easier attachment
 - Non-slip hex geometry to prevent socket and fastener rounding
 - Milwaukee's Lifetime Guarantee covers impact sockets and extensions only
 - Meets ASME Industry Standards
 - Laser-etched part numbers
 - Includes: 10mm, 11mm, 12mm, 13mm, 14mm, 15mm, 16mm, 17mm, 18mm, 19mm, 20mm, 21mm, 22mm, 24mm, 3/8", 7/16", 1/2", 9/16", 5/8", 11/16", 3/4", 13/16", 7/8", 15/16", 1", 1-1/16", 1-1/8" Standard sockets
 - No. of Pieces: 27
 - **Manufacturer's Warranty:**
Lifetime Warranty
- Model No. UAV603**
Mfg. No. 49-66-6819
Price/Each \$165.00

Milwaukee



SHOCKWAVE IMPACT DUTY™ PACKOUT™ 3/8" DRIVE SAE DEEP SOCKET SET

- Optimized for use with 3/8" drive impact wrenches, drivers, ratchets, and adapters
 - Set comes in Packout™ Organizer
 - Stamped and ink filled diameter markings for wear resistance
 - 6-Point design made with forged impact steel for durability in high torque applications
 - Dual hole design and groove for easier attachment
 - Non-slip hex geometry to prevent socket and fastener rounding
 - Milwaukee's Lifetime Guarantee covers impact sockets and extensions only
 - Sets can be kept organized in the included MILWAUKEE® Packout™ Compact Low-Profile Organizer with a clear top for easy identification of parts at a glance
 - Meets ASME Industry Standards
 - Includes: 1/4", 9/32", 5/16", 11/32", 3/8", 7/16", 1/2", 9/16", 5/8", 11/16", 3/4", 13/16", 7/8", 15/16" Deep SAE sockets, 1/4" Hex to 3/8" square socket adapter, 3" Extension, 3/8" Universal joint
 - No. of Pieces: 17
 - **Manufacturer's Warranty:**
Lifetime Warranty
- Model No. UAV592**
Mfg. No. 49-66-6800
Price/Each \$140.00

Milwaukee



SHOCKWAVE IMPACT DUTY™ PACKOUT™ 3/8" DRIVE METRIC DEEP SOCKET SET

- Optimized for use with 3/8" drive impact wrenches, drivers, ratchets, and adapters
 - Set comes in Packout™ Organizer
 - Stamped and ink filled diameter markings for wear resistance
 - 6-Point design made with forged impact steel for durability in high torque applications
 - Dual hole design and groove for easier attachment
 - Non-slip hex geometry to prevent socket and fastener rounding
 - Sets can be kept organized in the included MILWAUKEE® Packout™ Compact Low-Profile Organizer with a clear top for easy identification of parts at a glance
 - Meets ASME Industry Standards
 - Includes: 6mm, 7mm, 8mm, 9mm, 10mm, 11mm, 12mm, 13mm, 14mm, 15mm, 16mm, 17mm, 18mm, 19mm, 20mm, 21mm, 22mm, 23mm, 24mm Deep metric sockets
 - No. of Pieces: 19
 - **Manufacturer's Warranty:**
Lifetime Warranty
- Model No. UAV593**
Mfg. No. 49-66-6801
Price/Each \$140.00

Milwaukee



21-PIECE SAE 12-POINT SOCKET WRENCH SET

- Drive Size: 3/8"
 - Includes: Deep Length Sockets (3/8, 7/16, 1/2, 9/16, 5/8, 11/16, 3/4, 13/16"), Standard Length Sockets (3/8, 7/16, 1/2, 9/16, 5/8, 11/16, 3/4"), 8" 48-Tooth quick release oval head ratchet (671926), 3" (671905) & 6" (671907) Extensions, 8" Flex handle (671902), 1-7/8" Universal joint (671910), Blow mould case with removable lid
- Model No. AUW031**
Mfg. No. 600230
Price/Each \$174.00

JET



RATCHET & SOCKET SET WITH PACKOUT™ LOW-PROFILE COMPACT ORGANIZER

- Sockets with Four Flat™ Sides on socket deter rolling
 - Ratchet has 90 tooth design with 4-degree arc swing for tight work spaces
 - Ratchet has a flush directional lever
 - Packout™ organizer has an impact resistant body
 - Packout™ organizer has clear top for easy identification of contents
 - Packout™ organizer has reinforced hinge
 - Four Flat™ Sides feature wrench-ready design
 - Ratchet and socket set with slim profile ratchet
 - Sockets with stamped sizes
 - Packout™ organizer has a IP65 Rated Protection
 - Packout™ organizer has heavy-duty latches
 - Drive Size: 3/8"
 - No. of Pieces: 32
 - **Manufacturer's Warranty:**
Lifetime Warranty
- Model No. TER122**
Mfg. No. 48-22-9482
Price/Each \$149.00

Milwaukee



SHOCKWAVE IMPACT DUTY™ PACKOUT™ 3/8" DRIVE DEEP SOCKET SET

- Optimized for use with 3/8" drive impact wrenches, drivers, ratchets, and adapters
- Set comes in Packout™ Organizer
- Stamped and ink filled diameter markings for wear resistance
- 6-Point design made with forged impact steel for durability in high torque applications
- Dual hole design and groove for easier attachment
- Non-slip hex geometry to prevent socket and fastener rounding
- Milwaukee's Lifetime Guarantee covers impact sockets and extensions only
- Sets can be kept organized in the included MILWAUKEE® Packout™ Compact Low-Profile Organizer with a clear top for easy identification of parts at a glance
- Meets ASME Industry Standards
- Includes: 1/4", 9/32", 5/16", 11/32", 3/8", 7/16", 1/2", 9/16", 5/8", 11/16", 3/4", 13/16", 7/8", 15/16" Deep sockets, 1/4" Hex to 3/8" square socket adapter, 3" Extension, 3/8" Universal joint, 6mm, 7mm, 8mm, 9mm, 10mm, 11mm, 12mm, 13mm, 14mm, 15mm, 16mm, 17mm, 18mm, 19mm, 20mm, 21mm, 22mm, 23mm, 24mm Deep sockets
- No. of Pieces: 36

Manufacturer's Warranty:
Lifetime Warranty

Model No. UAV597
Mfg. No. 49-66-6805
Price/Each \$290.00



SHOCKWAVE IMPACT DUTY™ PACKOUT™ 3/8" DRIVE DEEP SOCKET SET

- Optimized for use with 3/8" drive impact wrenches, drivers, ratchets, and adapters
- Tray compatible with PACKOUT™ Organizers (48-22-8436) and (48-22-8431) and fit in tool chest drawers
- Stamped and ink filled diameter markings for wear resistance
- 6-Point design made with forged impact steel for durability in high torque applications
- Dual hole design and groove for easier attachment
- Non-slip hex geometry to prevent socket and fastener rounding
- Milwaukee's Lifetime Guarantee covers impact sockets and extensions only
- Meets ASME Industry Standards
- Includes: 1/4", 9/32", 5/16", 11/32", 3/8", 7/16" 1/2", 9/16", 5/8", 11/16", 3/4", 13/16", 7/8", 15/16" Deep SAE sockets, 1/4" Hex to 3/8" square socket adapter, 3" Extension, 3/8" Universal joint
- No. of Pieces: 17

Manufacturer's Warranty:
Lifetime Warranty

Model No. UAV599
Mfg. No. 49-66-6815
Price/Each \$119.00



SHOCKWAVE IMPACT DUTY™ PACKOUT™ 3/8" DRIVE DEEP SOCKET SET

- Optimized for use with 3/8" drive impact wrenches, drivers, ratchets, and adapters
- Tray Compatible with PACKOUT™ Organizers (48-22-8436) and (48-22-8431) and fit in tool chest drawers
- Stamped and ink filled diameter markings for wear resistance
- 6-Point design made with forged impact steel for durability in high torque applications
- Dual hole design and groove for easier attachment
- Non-slip hex geometry to prevent socket and fastener rounding
- Milwaukee's Lifetime Guarantee covers impact sockets and extensions only
- Meets ASME Industry Standards
- Includes: 6mm, 7mm, 8mm, 9mm, 10mm, 11mm, 12mm, 13mm, 14mm, 15mm, 16mm, 17mm, 18mm, 19mm, 20mm, 21mm, 22mm, 23mm, 24mm Deep metric sockets
- No. of Pieces: 19

Manufacturer's Warranty:
Lifetime Warranty

Model No. UAV600
Mfg. No. 49-66-6816
Price/Each \$119.00



26-PC. 3/8" DRIVE METRIC SOCKET & ATTACHMENT SET



- Made from premium steel for maximum durability
- Designed for use on 6 and 12-point fasteners
- Hex openings deliver maximum turning power without rounding fasteners
- **Limited lifetime warranty**
- Drive Size: 3/8"
- Drive Type: 12 Point
- Packaged in: Metal Case
- Contains: Standard 9 mm, 10 mm, 11 mm, 12 mm, 13 mm, 14 mm, 15 mm, 16 mm, 17 mm, 18 mm, 19mm sockets, Deep 9 mm, 10 mm, 11 mm, 11 mm, 12 mm, 13 mm, 14 mm, 15 mm, 16 mm, 17 mm, 18 mm, 19 mm sockets, Reversible Ratchet, U-Joint, 3" & 6" Extensions

Model No. TYR428
Price/Each \$445.00



26-PC. 3/8" DRIVE S.A.E. SOCKET & ATTACHMENT SET



- Made from premium steel for maximum durability
- Designed for use on 6 and 12-point fasteners
- Hex openings deliver maximum turning power without rounding fasteners
- **Limited lifetime warranty**
- Drive Size: 3/8"
- Drive Type: 12 Point
- Packaged in: Metal Case
- Contains: Standard 3/8", 7/16", 1/2", 9/16", 5/8", 11/16", 3/4", 13/16", 7/8", 15/16", 1" sockets, Deep 3/8", 7/16", 1/2", 9/16", 5/8", 11/16", 3/4", 13/16", 7/8", 15/16", 1" sockets, Reversible Ratchet, U-Joint and 3" & 6" Extensions

Model No. TYR402
Price/Each \$499.00



6- & 12-POINT MECHANIC'S TOOL SET

- Chrome Vanadium steel sockets and drive tools
- 1/4", 3/8", and 1/2" drive SAE and Metric sockets in 6 point, 12 point, regular, and deep styles for maximum versatility
- Quick-release 36 tooth ratchets with heavy-duty pawls exceed ANSI standards for torque and tolerance
- All components meet ANSI standards
- Combination wrenches, hex keys, nut setters, and screwdriver bits in one convenient high impact blow mould case – ready for any job!
- No. of Pieces: 200

Model No. UAV825
Mfg. No. 020304
Price/Each \$335.00



SOCKETS

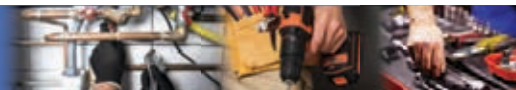

1/4" REVERSIBLE RATCHETS

Model No. TYR598 5" L
Mfg. No. V2536
Price/Each \$60.90



1/4" FLEX HANDLES

Model No. YB167 5 1/2" L
Mfg. No. V26
Price/Each \$34.50



1/4" HAND DRIVERS

Model No. TYQ576 6" L
Mfg. No. V780
Price/Each \$22.50



EXTENSIONS

Model No.	Mfg. No.	Overall Length"	Description	Price /Each
YB168	V602	2	Fixed	10.90
TYR320	V603	3	Fixed	14.50
TYR322	V606	6	Fixed	15.50
TYR324	V610	10	Fixed	21.90
TYR325	V614	14	Fixed	25.50
TYR319	V602W	2	Wobble	15.90
TYR321	V604W	4	Wobble	21.90
TYR323	V606W	6	Wobble	25.50

1/4" DRIVE ACCESSORIES

6-POINT S.A.E. STANDARD LENGTH SOCKETS



Model No.	Mfg. No.	Hex Size"	Overall Length"	Price /Each
TYQ748	V5	5/32	0.88	7.89
TYQ749	V6	3/16	0.88	7.99
TYQ750	V7	7/32	0.88	7.99
TYQ751	V8	1/4	0.88	8.09
YC137	V9	9/32	0.88	8.09
TYQ734	V10	5/16	0.88	8.39
YB125	V11	11/32	0.88	8.39
TYQ745	V12	3/8	0.88	8.39
YB126	V14	7/16	0.88	8.39
TYQ746	V16	1/2	0.88	8.49
TYQ747	V18	9/16	0.88	8.49

6-POINT S.A.E. DEEP LENGTH SOCKETS



Model No.	Mfg. No.	Hex Size"	Overall Length"	Price /Each
TYR087	VL6	3/16	2.00	12.50
TYR088	VL7	7/32	2.00	12.50
TYR089	VL8	1/4	2.00	12.50
YB129	VL9	9/32	2.00	12.90
TYR071	VL10	5/16	2.00	12.50
TYR076	VL11	11/32	2.00	12.90
TYR083	VL12	3/8	2.00	12.90
TYR084	VL14	7/16	2.00	12.90
TYR085	VL16	1/2	2.00	12.90
TYR086	VL18	9/16	2.00	12.90

12-POINT S.A.E. STANDARD LENGTH SOCKETS



Model No.	Mfg. No.	Hex Size"	Overall Length"	Price /Each
TYQ735	V106	3/16	0.88	8.49
TYQ736	V107	7/32	0.88	8.49
TYQ737	V108	1/4	0.88	8.59
TYQ738	V109	9/32	0.88	8.69
TYQ739	V110	5/16	0.88	8.69
TYQ740	V111	11/32	0.88	8.69
TYQ741	V112	3/8	0.88	8.69
TYQ742	V114	7/16	0.88	8.99
TYQ743	V116	1/2	0.88	9.09
TYQ744	V118	9/16	0.88	9.19

12-POINT S.A.E. DEEP LENGTH SOCKETS



Model No.	Mfg. No.	Hex Size"	Overall Length"	Price /Each
TYR072	VL106	3/16	2.00	12.90
TYR073	VL107	7/32	2.00	12.90
TYR074	VL108	1/4	2.00	12.90
TYR075	VL109	9/32	2.00	12.90
TYR077	VL110	5/16	2.00	12.90
TYR078	VL111	11/32	2.00	12.90
TYR079	VL112	3/8	2.00	12.90
TYR080	VL114	7/16	2.00	12.90
TYR081	VL116	1/2	2.00	12.90
TYR082	VL118	9/16	2.00	12.90

6-POINT METRIC STANDARD LENGTH SOCKETS



Model No.	Mfg. No.	Hex Size mm	Overall Length mm	Price /Each
TYQ708	M604	4	22.25	8.69
TYQ709	M604.5	4.5	22.25	8.69
TYQ710	M605	5	22.25	8.79
TYQ711	M605.5	5.5	22.25	8.79
TYQ712	M606	6	22.25	8.99
TYQ713	M607	7	22.25	9.09
TYQ714	M608	8	22.25	9.09
TYQ715	M609	9	22.25	9.19
TYQ716	M610	10	22.25	9.19
TYQ717	M611	11	22.25	9.19
TYQ718	M612	12	22.25	9.19
TYQ719	M613	13	22.25	9.29
TYQ720	M614	14	22.25	9.29
TYQ721	M615	15	22.25	9.19

6-POINT METRIC DEEP LENGTH SOCKETS



Model No.	Mfg. No.	Hex Size mm	Overall Length mm	Price /Each
TYR049	ML604	4	50.8	13.50
TYR050	ML605	5	50.8	13.50
TYR051	ML605.5	5.5	50.8	13.50
TYR052	ML606	6	50.8	13.90
TYR053	ML607	7	50.8	13.90
TYR054	ML608	8	50.8	13.50
TYR055	ML609	9	50.8	13.90
TYR056	ML610	10	50.8	13.50
TYR057	ML611	11	50.8	13.50
TYR058	ML612	12	50.8	13.90
TYR059	ML613	13	50.8	13.50
TYR060	ML614	14	50.8	13.50

UNIVERSAL JOINTS



Model No.	Mfg. No.	Price /Each
TYR280	V760	34.50

ADAPTORS



Model No.	Mfg. No.	Size"	Price /Each
TYR241	4217	1/4 F x 3/8 M	12.50



1/4" DRIVE RATCHETS

Model No. TYL032 5 1/2" L
Price/Each \$9.85



TYL032

1/4" DRIVE QUICK-RELEASE RATCHETS

Model No. TLV363 5 3/4" L
Price/Each \$23.90



TLV363

1/4" DRIVE HINGE HANDLES

Model No. TYL033 5 3/4" L
Price/Each \$8.75



TYL033

1/4" PLASTIC HANDLE DRIVERS

Model No. TLV445 5 3/4" L
Price/Each \$7.95



TLV445

1/4" DRIVE QUICK-RELEASE RUBBER GRIP RATCHETS

Model No. TLV380 6" L
Price/Each \$17.30



TLV380

AURORA
TOOLS

EXTENSIONS



TYL034

Model No.	Overall Length"	Price /Each
TYK843	2	2.30
TLV446	4	3.20
TYL034	6	3.20



ADAPTORS

Model No.	Size"	Price /Each
TYL035	1/4 F x 3/8 M	2.60

1/4" DRIVE ACCESSORIES

6-POINT S.A.E STANDARD LENGTH SOCKETS



Model No.	Hex Size"	Overall Length"	Price /Each
TYK732	5/32	1	2.10
TYK733	3/16	1	2.10
TYK734	7/32	1	2.10
TYK735	1/4	1	2.10
TYK736	9/32	1	2.10
TYK737	5/16	1	2.10
TYK738	11/32	1	2.10
TYK739	3/8	1	2.10
TYK740	7/16	1	2.10
TYK741	1/2	1	2.10
TYK742	9/16	1	2.10

6-POINT S.A.E DEEP LENGTH SOCKETS



Model No.	Hex Size"	Overall Length"	Price /Each
TYK791	5/32	2	2.40
TYK792	3/16	2	2.40
TYK793	7/32	2	2.40
TLV496	1/4	2	2.40
TYK794	9/32	2	2.40
TYK795	5/16	2	2.40
TYK796	11/32	2	2.40
TYK797	3/8	2	2.40
TYK798	7/16	2	2.50
TYK799	1/2	2	2.60
TYK800	9/16	2	2.80

6-POINT METRIC STANDARD LENGTH SOCKETS



Model No.	Hex Size"	Overall Length"	Price /Each
TYK743	4	25	2.10
TYK744	4.5	25	2.10
TYK745	5	25	2.10
TYK746	5.5	25	2.10
TYK747	6	25	2.10
TYK748	7	25	2.10
TYK591	8	25	2.10
TYK750	9	25	2.10
TYK592	10	25	2.10
TYK752	11	25	2.10
TYK753	12	25	2.10
TYK754	13	25	2.10
TYK755	14	25	2.10

6-POINT METRIC DEEP LENGTH SOCKETS



Model No.	Hex Size"	Overall Length"	Price /Each
TYK801	4	50	2.40
TYK802	4.5	50	2.40
TYK803	5	50	2.40
TYK804	5.5	50	2.40
TYK805	6	50	2.40
TLV497	7	50	2.40
TLV553	8	50	2.40
TYK806	9	50	2.40
TLV498	10	50	2.40
TYK807	11	50	2.40
TYK808	12	50	2.50
TYK809	13	50	2.60
TYK810	14	50	2.80

3/8" DRIVE RATCHETS

Model No. TNB484 7 7/8" L
Price/Each \$13.70



TNB484

3/8" DRIVE QUICK-RELEASE RATCHETS

Model No. TLV364 8" L Price/Each \$25.25



TLV364

3/8" DRIVE HINGE HANDLES

Model No. TYL037 9 1/2" L Price/Each \$16.95
Model No. TYL038 8 1/2" L Price/Each \$11.75



TYL037

3/8" DRIVE QUICK-RELEASE RUBBER GRIP RATCHET

Model No. TLV381 8" L
Price/Each \$21.40



TLV381

AURORA

TOOLS

EXTENSIONS



Model No.	Overall Length"	Price /Each
TLV365	3	2.60
TLV366	6	3.55
TJZ226	8	5.25
TYL040	10	6.15

ADAPTORS

Model No.	Size"	Price /Each
TYL041	3/8 Fx 1/4 M	1.95
TYK847	3/8 Fx 1/2 M	2.35



3/8" DRIVE ACCESSORIES

6-POINT S.A.E STANDARD LENGTH SOCKETS



Model No.	Hex Size"	Length"	Price /Each
TLV367	1/4	1.13	2.10
TLV368	5/16	1.13	2.10
TYK756	3/8	1.13	2.10
TLV488	7/16	1.13	2.10
TMB048	1/2	1.13	2.10
TLV369	9/16	1.13	2.20
TYK757	5/8	1.13	2.30
TLV473	11/16	1.19	2.40
TLV474	3/4	1.19	2.50
TMB044	13/16	1.19	2.80
TMB045	7/8	1.19	2.95

6-POINT S.A.E DEEP LENGTH SOCKETS

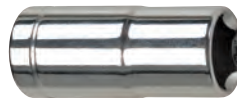

Model No.	Hex Size"	Length"	Price /Each
TYL048	1/4	2.5	2.95
TYK811	5/16	2.5	3.10
TYK812	3/8	2.5	3.15
TLV370	7/16	2.5	3.20
TLV371	1/2	2.5	3.30
TLV372	9/16	2.5	3.60
TMB047	5/8	2.5	3.75
TLV475	11/16	2.5	4.10
TLV373	3/4	2.5	4.70
TLV374	13/16	2.5	5.40
TLV476	7/8	2.5	5.60

SPARK PLUG SOCKETS



Model No.	Hex Size"	Price /Each
TYL042	5/8	3.75
TYL043	13/16	4.60

UNIVERSAL JOINTS



Model No.	Price /Each
TYK844	6.50

6-POINT METRIC STANDARD LENGTH SOCKETS



Model No.	Hex Size mm	Length mm	Price /Each
TYK758	6	28	2.10
TYK759	7	28	2.10
TYK760	8	28	2.10
TYK761	9	28	2.10
TMB046	10	28	2.10
TYK762	11	28	2.10
TMB049	12	28	2.10
TMB052	13	28	2.10
TYK763	14	28	2.30
TYK764	15	28	2.30
TYK765	16	28	2.35
TYK766	17	30	2.40
TYK767	18	30	2.50
TMB054	19	30	2.75
TYL044	20	30	2.85
TYL045	21	30	2.95
TYL046	22	30	3.10
UAD527	23	30	5.70

6-POINT METRIC DEEP LENGTH SOCKETS



Model No.	Hex Size mm	Length mm	Price /Each
TYL050	6	63	2.95
TYK593	7	63	3.00
TYK813	8	63	3.10
TYK814	9	63	3.15
TYK815	10	63	3.20
TYK816	11	63	3.25
TMB053	12	63	3.30
TYK817	13	63	3.30
TYK818	14	63	3.35
TYK819	15	63	3.50
TYK820	16	63	3.60
TYK821	17	63	3.70
TYK822	18	63	3.90
TYK823	19	63	4.00
TYL052	20	63	4.25
TYL053	21	63	4.40
TYL054	22	63	4.65
TYL055	23	63	4.85

Stay safe & work confidently with

ZENITH[®]
Safety Products



1/2" DRIVE RATCHETS

Model No. TLV375 10" L
Price/Each \$24.90



TLV375

1/2" DRIVE QUICK-RELEASE RATCHETS

Model No. TLV376 10" L
Price/Each \$36.35



TLV376

1/2" DRIVE HINGE HANDLES

Model No. TTB977 14 1/4" L
Price/Each \$35.85



TTB977

1/2" DRIVE QUICK-RELEASE RUBBER GRIP RATCHETS

Model No. TLV382 10" L
Price/Each \$27.45



TLV382

1/2" DRIVE ACCESSORIES

6-POINT S.A.E STANDARD LENGTH SOCKETS



Model No.	Hex Size"	Length"	Price /Each
TYK768	3/8	1.5	2.50
TYK769	7/16	1.5	2.60
TTB978	1/2	1.5	2.70
TMB050	9/16	1.5	2.75
TYK771	5/8	1.5	2.75
TYJ946	11/16	1.5	2.90
TMB051	3/4	1.5	2.95
TYK648	13/16	1.5	3.00
TMB728	7/8	1.5	3.50
TYL059	15/16	1.56	3.85
TYK775	1	1.69	4.60
TYL060	1 1/16	1.81	4.90
TYL061	1 1/8	1.81	5.50
TYL062	1 3/16	1.81	5.65
TYL063	1 1/4	1.81	5.75

6-POINT S.A.E DEEP LENGTH SOCKETS



Model No.	Hex Size"	Length"	Price /Each
TYK824	7/16	3.06	4.60
TYK825	1/2	3.06	4.60
TYK826	9/16	3.06	4.60
TYK827	5/8	3.06	4.60
TYK828	11/16	3.06	4.75
TYK829	3/4	3.06	4.75
TYK830	13/16	3.06	5.50
TYK831	7/8	3.06	5.85
TLV379	15/16	3.06	6.80
TYL067	1	3.06	7.40
TYL068	1 1/16	3.06	8.95
TYK649	1 1/8	3.06	10.60
TYL069	1 1/4	3.06	11.60

6-POINT METRIC STANDARD LENGTH SOCKETS



Model No.	Hex Size mm	Length mm	Price /Each
TYK776	10	38	2.65
TYK777	11	38	2.65
TYK778	12	38	2.65
TYK779	13	38	2.65
TYK780	14	38	2.75
TYK781	15	38	2.75
TYK782	16	38	2.75
TYK783	17	38	2.75
TYK784	18	38	2.95
TYK785	19	38	3.40
TYK786	20	38	3.35
TYK787	21	38	3.50
TYK788	22	38	3.80
TYK789	23	40	3.85
TYK790	24	40	4.20
TYL064	27	44	4.75
TYL065	30	44	6.50
TYL066	32	44	6.75

6-POINT METRIC DEEP LENGTH SOCKETS



Model No.	Hex Size mm	Length mm	Price /Each
TYK832	10	77	4.75
TYK833	11	77	4.75
TYK834	12	77	4.75
TYK835	13	77	4.85
TYK836	14	77	5.00
TYL070	15	77	5.10
TYK837	16	77	5.15
TYK838	17	77	5.20
TYL071	18	77	5.20
TYK839	19	77	5.25
TYK840	20	77	5.40
TYK841	21	77	5.80
TYK842	22	77	6.15
TYL072	23	77	6.20
TYL073	24	77	6.30
TYL074	27	77	8.20
TYL075	30	77	9.95
TYL076	32	77	10.50

AURORA TOOLS

EXTENSIONS



Model No.	Overall Length"	Price /Each
TYL058	3	3.95
TLV377	5	4.55
TYK848	10	7.20

SPEEDERS



Model No.	Overall Length"	Price /Each
TNB489	16 1/2	18.90

ADAPTORS

Model No.	Size"	Price /Each
TYL056	1/2 F x 3/8 M	3.20
TYL057	1/2 F x 3/4 M	8.95



SPARK PLUG SOCKETS

Model No.	Hex Size"	Price /Each
TYK845	5/8	4.40
TYK846	13/16	4.80



UNIVERSAL JOINTS

Model No.	Price /Each
TLV378	7.30



SOCKETS

270° SWIVEL HEAD RATCHET WRENCH

- Unique 270° rotating head provides ultimate flex head function
- Only the head rotates, providing maximum flex positions while maintaining smallest profile
- 72-tooth quick-release ratchet head requires only 5° swing room
- Convenient direction switch on head is accessible from any angle
- Chrome Vanadium steel handle with Chrome Molybdenum drive gears
- Co-moulded handle grip provides all day comfort and sure grip
- Overall Length: 11-7/8"
- Drive Size: 1/2"
- Handle: Ergonomic

Model No. AUW041
Mfg. No. 672922
Price/Each \$123.00



72-TOOTH HEAVY-DUTY RATCHET WRENCH

- 72-tooth quick-release ratchet head requires only 5° swing room
- Ideal for fasteners in restricted areas
- Extra heavy pawl spring keeps 8 teeth engaged at all times for maximum strength
- Quick-release feature locks accessories to ratchet
- One piece drop forged head and handle
- Overall Length: 20"
- Drive Size: 3/4"
- Handle: Plain

Model No. AUW044
Mfg. No. 673924
Price/Each \$340.00



3/8" DRIVE S.A.E. HEX BIT SETS

- Standard length
- Includes socket bar and clips

Model No. TYR413
Price/Each \$109.00



Model No.	Mfg. No.	Size"
YB124	TW4	1/8
TYR038	TW5	5/32
TYR040	TW6	3/16
TYR042	TW7	7/32
TYR044	TW8	1/4
YB122	TW10	5/16
TE468	TW12	3/8



1/2" DRIVE METRIC HEX BIT SETS

- Standard length
- Includes socket bar and clips

Model No. TYR451
Price/Each \$215.00



Model No.	Mfg. No.	Size mm
TYQ559	MDW6L	6
TYQ561	MDW8L	8
TYQ549	MDW10L	10
TYQ551	MDW12L	12
TYQ553	MDW14L	14
TYQ555	MDW17L	17
TYQ557	MDW19L	17



RATCHET WRENCH

- Push button quick-release holds socket securely
- Convenient easy-use reversing switch
- Meets or exceeds ANSI specifications
- Overall Length: 10"
- Drive Size: 1/2"
- Handle: Plain
- Material: Chrome Vanadium Steel

Model No. UAV839
Mfg. No. 025595
Price/Each \$47.90



38-PC. 1/2" DRIVE S.A.E. & METRIC SOCKET & ATTACHMENT SET

- Mirror chrome finish for maximum resistance against corrosion
- Made from premium steel for maximum durability
- Ideal for use on stubborn, damaged or worn fasteners
- Hex openings deliver maximum turning power without rounding fasteners
- **Limited lifetime warranty**
- Drive Size: 1/2"
- Contains: 3/8", 7/16", 1/2", 9/16", 5/8", 11/16", 3/4", 13/16", 7/8", 15/16", 1", 1-1/16", 1-1/8", 1-1/4", 10 mm, 11 mm, 12 mm, 13 mm, 14 mm, 15 mm, 16 mm, 17 mm, 18 mm, 19 mm, 20 mm, 21 mm, 22 mm, 23 mm, 24 mm, 27 mm, 30 mm, 32 mm sockets, Reversible Ratchet, 15" Flexible Handle, U-Joint and 2", 5" & 10" Extensions
- Drive Type: 6 Point
- Packaged in: Plastic Case

Model No. TYR444
Price/Each \$795.00



38-PC. 1/2" DRIVE S.A.E. & METRIC SOCKET & ATTACHMENTS SET

- Mirror chrome finish for maximum resistance against corrosion
- Made from premium steel for maximum durability
- Ideal for use on stubborn, damaged or worn fasteners
- Hex openings deliver maximum turning power without rounding fasteners
- **Limited lifetime warranty**
- Drive Size: 1/2"
- Contains: 3/8", 7/16", 1/2", 9/16", 5/8", 11/16", 3/4", 13/16", 7/8", 15/16", 1", 1-1/8", 1-1/4", 10 mm, 11 mm, 12 mm, 13 mm, 14 mm, 15 mm, 16 mm, 17 mm, 18 mm, 19 mm, 20 mm, 21 mm, 22 mm, 23 mm, 24 mm, 27 mm, 30 mm, 32 mm sockets, Reversible Ratchet, 15" Flexible Handle, U-Joint and 2", 5" & 10" Extensions
- Drive Type: 12 Point
- Packaged in: Plastic Case

Model No. TYR443
Price/Each \$795.00





1 1/2" DRIVE SOCKETS 6-POINT STANDARD IMPACT

Model No.	Mfg. No.	Size"	Overall Length"	Price /Each
TYQ881	8-664	2	3.43	205.00
TYQ882	8-666	2 1/16	3.43	205.00
TYQ883	8-668	2 1/8	3.54	215.00
TYQ884	8-670	2 3/16	3.54	219.00
TYQ885	8-672	2 1/4	3.62	239.00
TYQ887	8-676	2 3/8	3.62	285.00
TYQ888	8-678	2 7/16	3.74	285.00
TYQ889	8-680	2 1/2	3.74	285.00
TYQ891	8-684	2 5/8	3.94	309.00
TYQ893	8-688	2 3/4	3.94	359.00
TYQ895	8-692	2 7/8	4.06	389.00
TYQ897	8-696	3	4.06	435.00
TYQ898	8-698	3	4.33	469.00
NJH077	8-6100	3 1/8	4.33	489.00
TYW930	8-6102	3 1/5	4.33	495.00
NJH078	8-6104	3 1/4	4.33	495.00
TYW932	8-6108	3 3/8	4.65	525.00
TYW934	8-6112	3 1/2	4.65	545.00
TYW936	8-6116	3 5/8	4.65	709.00
TYW938	8-6120	3 3/4	4.65	805.00
TYW940	8-6124	3 7/8	4.92	919.00
NJH079	8-6128	4	4.92	969.00
TYW942	8-6130	4 1/16	4.92	979.00
TYW943	8-6132	4 1/8	4.92	1029.00
TYW944	8-6134	4 3/16	4.92	1045.00
TYW945	8-6136	4 1/4	4.92	1045.00
TYW946	8-6138	4 5/16	4.92	1105.00
TYW947	8-6140	4 3/8	4.92	1169.00
TYW949	8-6144	4 1/2	5.31	1225.00
TYW950	8-6148	4 5/8	5.31	1285.00
TYW951	8-6152	4 3/4	5.31	1429.00



1 1/2" DRIVE SOCKETS 6-POINT STANDARD IMPACT

Model No.	Mfg. No.	Size"	Overall Length"	Price /Each
TYQ925	9-696	3	5.25	1405.00
TYW953	9-6100	3 1/8	5.25	1105.00
TYW954	9-6104	3 1/4	5.25	1189.00
TYW955	9-6108	3 3/8	5.25	1255.00
TYW957	9-6112	3 1/2	5.5	1289.00
TYW959	9-6120	3 3/4	5.75	1445.00
TYW961	9-6128	4	6	1645.00
TYW962	9-6132	4 1/8	6.25	1679.00
TYW963	9-6136	4 1/4	6.5	1769.00
TYW964	9-6140	4 3/8	6.75	1915.00
TYW965	9-6144	4 1/2	7	1915.00
TYW966	9-6148	4 5/8	7	2055.00
TYW967	9-6152	4 3/4	7.25	2139.00
TYW969	9-6160	5	7.75	2295.00
TYW970	9-6164	5 1/8	7.75	2305.00
TYW971	9-6168	5 1/4	7.75	2419.00
TYW972	9-6176	5 1/2	8	2759.00
TYW973	9-6180	5 5/8	8	2799.00
TYW974	9-6184	5 3/4	8	2945.00
TYW975	9-6208	6 1/2	8.5	3529.00
TYW976	9-6220	6 7/8	8.5	4315.00
TYW977	9-6232	7 1/4	9	5055.00
TYW978	9-6244	7 5/8	9	5055.00
NJH119	9-6256	8	9.25	5509.00

1 1/2" DRIVE O-RINGS & RETAINER PINS



Model No.	Mfg. No.	Description	Price /Each
TYS153	PLR150	0.21" X 3.3" Outer Diameter Locking Ring	5.39
TYS152	PLP150	0.250 x 2.9 Long Locking Pin	3.59



1 1/2" DRIVE IMPACT EXTENSIONS

Model No.	Mfg. No.	Overall Length"	Price /Each
TYR530	P8-108	8	729.00



2 1/2" DRIVE SOCKETS 6-POINT DEEP - IMPACT

Model No.	Mfg. No.	Size"	Overall Length"	Price /Each
TYR141	9-6110L	3 7/16	7.75	1259.00
TYR142	9-6112L	3 1/2	7.75	1265.00
TYR143	9-6116L	3 5/8	8	1285.00
TYR144	9-6120L	3 3/4	8	1355.00
TYR145	9-6124L	3 7/8	8.25	1389.00
TYR146	9-6128L	4	8.25	1485.00
TYR147	9-6132L	4	8.5	1545.00
TYR148	9-6136L	4 1/8	8.75	1559.00
TYR149	9-6140L	4 1/4	8.75	1669.00
TYR150	9-6144L	4 3/8	9	1679.00
TYR151	9-6148L	4 1/2	9	1829.00
TYR152	9-6152L	4 5/8	9.25	1829.00
TYR153	9-6156L	4 3/4	9.5	1989.00
TYR154	9-6160L	5	9.75	1995.00



1 1/2" DRIVE SOCKETS 6-POINT DEEP - IMPACT



Model No.	Mfg. No.	Size"	Overall Length"	Price /Each
TYR123	8-664L	2	5.31	319.00
TYR124	8-666L	2 1/16	5.51	319.00
TYR125	8-668L	2 1/8	5.51	329.00
TYR126	8-670L	2 3/16	5.51	315.00
TYR127	8-672L	2 1/4	5.91	345.00
TYR128	8-674L	2 5/16	5.91	325.00
TYR129	8-676L	2 3/8	5.91	399.00
TYR131	8-680L	2 1/2	5.91	429.00
TYR133	8-684L	2 5/8	5.91	495.00
TYR135	8-688L	2 3/4	6.3	529.00
TYR137	8-692L	2 7/8	6.3	585.00
TYR139	8-696L	3	6.69	599.00
TYR140	8-698L	3	6.69	635.00
TYR090	8-6100L	3 1/8	6.69	715.00
TYR092	8-6104L	3 1/4	6.69	749.00
TYR094	8-6108L	3 3/8	6.69	819.00
TYR096	8-6112L	3 1/2	6.69	815.00
TYR098	8-6116L	3 5/8	6.69	855.00
TYR100	8-6120L	3 3/4	7.09	1169.00
TYR102	8-6124L	3 7/8	7.09	1199.00
TYR104	8-6128L	4	7.48	1239.00
TYR105	8-6130L	4 1/16	7.48	1209.00
TYR106	8-6134L	4 3/16	7.48	1489.00
TYR107	8-6136L	4 1/4	7.48	1569.00
TYR108	8-6138L	4 5/16	7.87	1745.00
TYR109	8-6140L	4 3/8	7.87	1879.00
TYR110	8-6144L	4 1/2	8.27	1945.00
TYR111	8-6148L	4 5/8	8.27	1995.00
TYR112	8-6152L	4 3/4	8.27	2125.00

TAKING THE STRESS OUT OF SPILLS



SOCKETS



5-PC. 6-POINT 3/8" DRIVE UNIVERSAL IMPACT SOCKET SETS

- Includes socket rail
- Includes the following sizes: 3/8", 7/16", 1/2", 9/16", 5/8"

Model No. TYR344
Mfg. No. 25805
Price/Each \$265.00



11-PC. 6-POINT 1/2" DRIVE DEEP IMPACT SOCKET SETS

- Includes socket rail
- Includes the following sizes: 3/8", 7/16", 1/2", 9/16", 5/8", 11/16", 3/4", 13/16", 7/8", 15/16", 1, 1-1/16", 1-1/8", 1-1/4"

Model No. TYQ627
Mfg. No. P11T
Price/Each \$149.00



8-PC. 6-POINT 3/8" DRIVE IMPACT SOCKET SETS

- Includes socket rail
- Includes the following sizes: 5/16", 3/8", 7/16", 1/2", 9/16", 5/8", 11/16", 3/4"

Model No. TYR453
Mfg. No. P8T
Price/Each \$72.90



10-PC. 6-POINT 1/2" DRIVE UNIVERSAL IMPACT SOCKET SETS

- Includes socket rail
- Includes the following sizes: 7/16", 1/2", 9/16", 5/8", 11/16", 3/4", 13/16", 7/8", 15/16", 1"

Model No. TYQ611
Mfg. No. 35810
Price/Each \$495.00



8-PC. 6-POINT 3/8" DRIVE DEEP IMPACT SOCKET SETS

- Includes socket rail
- Includes the following sizes: 5/16", 3/8", 7/16", 1/2", 9/16", 5/8", 11/16", 3/4"

Model No. TYR343
Mfg. No. 25058
Price/Each \$105.00



11-PC. 6-POINT 1/2" DRIVE DEEP IMPACT SOCKET SETS

- Includes socket rail
- Includes the following sizes: 3/8", 7/16", 1/2", 9/16", 5/8", 11/16", 3/4", 13/16", 7/8", 15/16", 1"

Model No. TYQ629
Mfg. No. PL11T
Price/Each \$225.00



12-PC. 6-POINT 3/8" DRIVE IMPACT SOCKET SETS - METRIC

- Includes socket rail
- Set contains sockets from 8 mm to 19 mm

Model No. TYR345
Mfg. No. 29612
Price/Each \$115.00



12-PC. 6-POINT 1/2" DRIVE IMPACT SOCKET SETS - METRIC

- Includes socket rail
- Set contains sockets from 8 mm to 19 mm

Model No. TYQ617
Mfg. No. 39062
Price/Each \$145.00



12-PC. 6-POINT 3/8" DRIVE DEEP IMPACT SOCKET SETS - METRIC

- Includes socket rail
- Set contains sockets from 8 mm to 19 mm

Model No. TYR346
Mfg. No. 29622
Price/Each \$155.00



14-PC. 6-POINT 1/2" DRIVE DEEP IMPACT SOCKET SETS - METRIC

- Includes socket rail
- Set contains sockets from 10 mm to 23 mm

Model No. TYQ619
Mfg. No. 39214
Price/Each \$289.00



10-PC. 6-POINT 3/4" DRIVE IMPACT SOCKET SETS

- Includes (2) socket rails
- Includes the following sizes: 15/16", 1", 1 1/16", 1 1/8", 1 1/4", 1 5/16", 1 3/8", 1 7/16", 1 1/2", 1 5/8"

Model No. TY121
Mfg. No. 45010
Price/Each \$369.00



10-PC. 6-POINT 3/4" DRIVE DEEP IMPACT SOCKET SETS

- Includes (2) socket rails
- Includes the following sizes: 15/16", 1", 1 1/16", 1 1/8", 1 1/4", 1 5/16", 1 3/8", 1 7/16", 1 1/2", 1 5/8"

Model No. TYQ622
Mfg. No. 45260
Price/Each \$539.00



IMPACT STANDARD SOCKET SETS 1/2" DRIVE

- Chrome molybdenum alloy steel (CR-MO) for exceptional strength and long lasting durability
- High visibility laser-etched markings
- Reinforced molded case with sizes marked for quick identification and storage
- 6-point sockets



GW GEARWRENCH

Model No.	Mfg. No.	No. of Pieces	Description	Price /Each
TLV393	84932N	19	SAE 3/8" to 1 1/2"	108.00
TLV394	84933N	25	Metric 8 mm to 36 mm	138.00

IMPACT DEEP SOCKET SETS, 1/2" DRIVE

- Chrome molybdenum alloy steel (CR-MO) for exceptional strength and long lasting durability
- High visibility laser-etched markings
- Reinforced molded case with sizes marked for quick identification and storage
- 6-point sockets



GW GEARWRENCH

Model No.	Mfg. No.	No. of Pieces	Description	Price /Each
TLV397	84934N	19	SAE 3/8" to 1 1/2"	202.00
TLV398	84935N	29	Metric 8 mm to 36 mm	249.00

12-PC. IMPACT STANDARD SOCKET SETS, 1/2" DRIVE

- Chrome molybdenum alloy steel (CR-MO) for exceptional strength and long lasting durability
- High visibility laser-etched markings
- Reinforced molded case with sizes marked for quick identification and storage
- 6-point sockets



GW GEARWRENCH

Model No.	Mfg. No.	Description	Price /Each
TLV391	84931N	SAE 3/8" to 1 1/16"	54.20
TLV392	84930N	Metric 8 mm to 19 mm	51.70

12-PC. IMPACT DEEP SOCKET SETS, 1/2" DRIVE

- Chrome molybdenum alloy steel (CR-MO) for exceptional strength and long lasting durability
- High visibility laser-etched markings
- Reinforced molded case with sizes marked for quick identification and storage
- 6-point sockets



GW GEARWRENCH

Model No.	Mfg. No.	Description	Price /Each
TLV395	84942N	SAE 3/8" to 1 1/16"	87.00

13-PC. IMPACT UNIVERSAL SOCKET SETS, 1/2" DRIVE

- Chrome molybdenum alloy steel (CR-MO) for exceptional strength and long lasting durability
- High visibility laser-etched markings
- Reinforced molded case with sizes marked for quick identification and storage
- 6-point sockets



GW GEARWRENCH

Model No.	Mfg. No.	Description	Price /Each
TLV399	84938N	SAE 1/2" to 1 1/4"	221.00
TLV400	84939N	Metric 10 mm to 24 mm	221.00

44-PC. IMPACT SAE/METRIC STANDARD & DEEP SOCKET SETS, 3/8" DRIVE

- Chrome molybdenum alloy steel (CR-MO) for exceptional strength and long lasting durability
- High visibility laser-etched markings
- Reinforced molded case with sizes marked for quick identification and storage

INCLUDES:

- 6-point 5/16" to 3/4" standard and deep sockets
- 6-point 8 mm to 19 mm standard and deep sockets, and a 21 mm deep socket
- 3 extensions (3", 6" and 10")

Model No. TLV390
Mfg. No. 84916N
Price/Each \$136.00



GW GEARWRENCH

TORQUE WRENCHES



DIAL TORQUE WRENCH

- Large easy-to-read dial
- Fast, accurate and easy to set in any industrial workplace
- Accuracy: $\pm 3\%$ CW $\pm 4\%$ CCW
- Includes custom molded plastic case



Model No.	Mfg. No.	Capacity		Increments		Drive Type"	Overall Length"	Price /Each
NKE124	DIN75B	0-75 in.-lbs.	0-9 Nm	5 in.-lbs.	0.25 Nm	1/4 Square	10.5	359.00
NKE123	DIN250B	0-250 in.-lbs.	0-30 Nm	5 in.-lbs.	0.50 Nm	3/8 Square	10.5	369.00
NJI147	DIN600B	0-600 in.-lbs.	0-70 Nm	10 in.-lbs.	2.0 Nm	3/8 Square	10.5	379.00

DIAL TORQUE WRENCH WITH MEMORY NEEDLE

- Large easy-to-read dial
- Fast, accurate and easy to set in any industrial workplace
- Accuracy: $\pm 3\%$ CW $\pm 4\%$ CCW
- Includes custom molded plastic case



Model No.	Mfg. No.	Capacity		Increments		Drive Type"	Overall Length"	Price /Each
QP111	DFN50B	0-50 ft.-lbs.	0-70 Nm	1 ft.-lbs.	2 Nm	3/8 Square	10.5	369.00
NJI146	DFN250B	0-250 ft.-lbs.	0-350 Nm	5 ft.-lbs.	10 Nm	1/2 Square	21.5	369.00

HEAVY-DUTY MICRO-ADJUSTABLE TORQUE WRENCH

- Power Source: AC
- Type of Bulb: LED
- Measurement System: Metric
- Rugged metal knurled handles
- Quick-release button for faster socket retention and removal
- Can be trusted in any automotive, aircraft, marine and industrial applications
- Operates and ratchets in both left and right hand directions
- Includes custom molded plastic case



Model No.	Mfg. No.	Drive Type"	Capacity		Increments		Overall Length"	Head Style	Price /Each
NJH064	81250	1/4 Square	30-250 in.-lbs.	4-28.8 Nm	1 in.-lbs.	0.11 Nm	12 1/2	Fixed	409.00
NJH066	82250	3/8 Square	30-250 in.-lbs.	4-28.8 Nm	1 in.-lbs.	0.11 Nm	12 1/2	Fixed	425.00
TYW979	MFR80FL	3/8 Square	10-80 ft.-lbs.	13.5 - 108.5 Nm	0.5 ft.-lbs.	1.4 Nm	16 1/2	Flex	429.00
NJH065	82100	3/8 Square	10-100 in.-lbs.	23.7-139 Nm	0.5 ft.-lbs.	0.7 Nm	17	Fixed	425.00
NJH070	83250	1/2 Square	30-250 in.-lbs.	47.5-345.8 Nm	1 ft.-lbs.	1.4 Nm	22	Fixed	515.00
TY272	MFR250H	1/2 Square	30-250 in.-lbs.	47-332 Nm	1 ft.-lbs.	1.4 Nm	24 1/4	Fixed	485.00
NJH075	84600	3/4 Square	100-600 in.-lbs.	169-847 Nm	5 ft.-lbs.	7.0 Nm	46	Fixed	1549.00
TY273	MFR600H	3/4 Square	100-600 in.-lbs.	169-779 Nm	5 ft.-lbs.	6.8 Nm	43	Fixed	1425.00
TYR634	MF2000	1 Square	300-2000 ft.-lbs.	474-2700 Nm	10 ft.-lbs.	13.5 Nm	109	Fixed	7335.00

TORQUE MULTIPLIER

- Accuracy: $\pm 5\%$



Model No.	Mfg. No.	Max Input Torque		Max Output Torque		Input Drive"	Output Drive"	Weight With Case	Price /Each
		ft. lbs.	Nm	ft. lbs.	Nm				
TYR665	TM750A	227	303	750	1017	1/2 F	3/4 M	4 lbs.	2455.00
TYR662	TM1200	200	271	1200	1627	1/2 F	3/4 M	12.5 lbs.	4345.00
TYR663	TM2200	162	271	2200	2983	1/2 F	1 M	15.2 lbs.	7269.00
TYR664	TM3200	173	235	3200	4339	1/2 F	1 M	19.9 lbs.	9485.00

BEAM TORQUE WRENCH

- Scale includes both SAE (In/Lb, Ft/Lb) and Metric (Nm)
- Serviceable by bending pointer to zero before use
- Palm-fit handle pivots on beam to maintain constant distance from drive point to load point for precise measurement
- Directly measure a variety of torque values when tightening fasteners
- Pointer moves clockwise or counter-clockwise ($\pm 7\%$) to measure torque



Model No.	Mfg. No.	Overall Length"	Drive Type"	Torque Range	Increments	Tool Weight lbs.	Price /Each
TDS979	2955D	11	1/4 Square	0-60 in.-lbs.	2.5 in.-lbs.	0.85	61.80
TDS941	2956D	16	3/8 Square	0-600 in.-lbs.	50 in.-lbs.	1.45	79.00
TDS949	2957N	20	1/2 Square	0-150 ft.-lbs.	5 ft.-lbs.	1.89	86.00

TORQUE WRENCHES

DIGITAL TORQUE WRENCH

- Digital readout signals torque audibly and visually
- 12 multi coloured lights with beeper signal torque even when display cannot be read
- Measures torque in both directions
- Accurate to +/-2% CW, +/-3% CCW from 20% - 100% of scale
- Quickly converts between in/lbs, ft/lbs, cm/kg, and Nm scales
- Stores up to 9 torque values for quick access to commonly used settings
- Display tracks torque as it is applied or can be set to display peak torque
- Records up to 50 Peak Hold values for accurate record keeping
- Large handle features soft touch TPR grip for user comfort
- Industrial quality 36-tooth sealed ratchet head
- Simple intuitive menu
- Encased in a blow mould case
- JET offers certified re-calibration service on torque wrenches
- LED lights signal torque
- Standard(s) Met: ISO 6789-1992, ANSI



AYW085

Model No.	Mfg. No.	Overall Length"	Drive Type	Torque Range	Price /Each
AYW085	718943	16-5/16	3/8" Square	6.3 - 135 N.m	461.00
AYW086	718946	25-1/2	1/2" Square	17 - 340 N.m	546.00

SUPER HEAVY-DUTY TORQUE WRENCH

- Magnified view window shows torque value in numbers only
- Highest quality Japanese spring resists fatigue for long service life
- Patented dual roller reaction bar system minimizes friction for increased accuracy
- Hardened steel tube will not deflect under strain and will not be scratched by internal parts, ensuring reduced friction and highest possible accuracy
- Conversion scale permanently etched into tube for easy conversion to Nm
- Patented positive lock prevents accidental adjustment of torque value
- Quick-release ratchet holds sockets on until released
- Sure grip handle with finger groove ensures correct placement of hand for better accuracy
- Features a 48-tooth quick release reversible ratchet head
- Drop forged Chrome Molybdenum ratchet pawls for maximum strength
- Lifetime tested to a minimum of 3 x ISO standards



AYW087



Model No.	Mfg. No.	Overall Length"	Drive Type	Torque Range	Price /Each
AYW087	718956	15-3/4"	3/8" Square	15 - 75 lbf. Ft	334.00
AYW088	718962	24-1/2"	1/2" Square	50 - 250 lbf. Ft	436.00

INDUSTRIAL SERIES TORQUE WRENCH

- All metal construction for the toughest, most demanding industrial applications
- Chrome Molybdenum ratchet pawls and teeth heat treated for maximum durability and high torque loads
- Quick-release ratchet head holds sockets and accessories safely and securely
- Accurate to +/-3% clockwise and +/-6% counter clockwise
- Hardened steel tube for long life and improved accuracy
- Knurled aluminum handle for safe, slip-resistant grip
- Extra dark scale and adjustment ring printing for improved visibility
- Dual scales for use on imperial or metric components
- All units calibrated in both directions and shipped complete with factory calibration certificate
- Complete with heavy-duty blow mould case
- Overall Length: 17"
- Standard(s) Met: ANSI, ISO, BSEN 26789-1994, GGG-W-00686C
- Grip Style: Non-Slip
- Style: Micrometer, Reversible, Left/right



AYW089

Model No.	Mfg. No.	Overall Length"	Drive Type	Torque Range	Number of Geared Teeth	Swing Arc	Price /Each
AYW089	718973	17	3/8" Square	20 - 100 lbf. Ft	32	11.2°	306.00
AYW090	718976	24	1/2" Square	50 - 250 lbf. Ft	32	11.2°	373.00
AYW091	718977	24	3/4" Square	150 - 600 lbf. Ft	24	15°	1212.00

TORQUE MULTIPLIER KIT

- Used to multiply applied force for setting and removing high torque fasteners
- Planetary gear system multiplies input force many times
- Torque multipliers lower physical effort, resulting in smooth, steady application of torque and increased accuracy
- Permits application of high torque without use of a long lever
- Can be driven with a torque wrench
- Kit includes straight and 90° reaction bars with reaction base (base not included in 719071 kit)
- 90° bar and base rests against truck wheel rims when used to torque lug nuts
- Higher ratios require lower input forces, reducing operator effort
- All models include breakaway input adaptor to protect wrench from overload



Model No.	Mfg. No.	Input Drive"	Output Drive"	Torque Ratio	Gear Ratio	Max. Input	Max. Output	Price /Each
AYW092	719072	1/2	3/4	6.5:1	0.375	170 ft-lb	1100 ft-lb	1491.00
AYW093	719075	3/4	1	3.3:1	0.167	560 ft-lb	1850 ft-lb	1464.00

120XP™ FLEX HEAD ELECTRONIC TORQUE WRENCH WITH ANGLE

- 120XP™ head provides a 3° ratcheting arc to turn fasteners in narrow spaces
- Torque accuracy of +/-2% CW and +/-3% CCW between 20% and 100% of wrench capability
- Angle settings offer +/-1% of reading of angle accuracy
- Low profile tube, 15° flex teardrop head, and flush mounted on/off switch allow for better access in tight confines
- Digitally tracks torque and angle measurements -- vibrating handle, buzzer, and LCD screen alert when target torque is reached
- 3 function modes feature peak torque, angle, and peak angle for additional versatility
- 5 torque measurement units provide a readout in ft-lb, in-lb, Nm, Kg-m, and Kg-cm
- 10 available pre-set torque settings allow you to quickly access frequently repeated applications

• Knurled aluminum handle lets you grip comfortably, while clearly
Model No. AYW201
Mfg. No. 85196
Price/Each \$393.00



- marked midpoint promotes additional accuracy
- Meets or exceeds ASME standards and specifications
- Packaging is recyclable
- Overall Length: 24-1/4"
- Drive Type: 1/2" Square
- Torque Range: 301 - 3010 in-lbs.
- Increments: 0.1 ft-lbs.
- Maximum Torque (Primary Scale): 250 ft/lb
- Battery Type: AA
- Head Width: 1-3/4"
- **Manufacturer's Warranty:**
1 Year Limited Warranty:
Calibration Accuracy for 90 Days



WRENCHES

ADJUSTABLE WRENCHES - MATTE FINISH



Model No.	Mfg. No.	Maximum Opening"	Length"	Price /Each
VT857	65304	1	3/16	39.50
TYQ425	65306A	1 1/4	7/32	41.50
TYQ427	65308A	1 1/2	7/32	42.90
TYQ429	65310A	1 3/4	7/32	54.90
TYQ431	65312A	1 1/2	12	79.50
TYQ433	65315A	2 1/4	1/4	119.00
VT863	65318	2 1/2	9/32	185.00
VT864	65324	3	5/16	369.00

ADJUSTABLE HEAD HOOK SPANNER WRENCHES



Model No.	Mfg. No.	Diameter Range"	Length"	Price /Each
TYQ451	AHS2	3/4 - 2	6 1/2	75.90
TYQ452	AHS3	1 1/4 - 3	8	84.50
TYQ453	AHS4	2 - 4 3/4	11 7/16	115.00
TYQ454	AHS6	4 1/2 - 6 1/4	12	119.00
TYQ455	AHS8	6 1/8 - 8 3/4	13 1/2	149.00

STRUCTURAL ADJUSTABLE WRENCH WITH SIDE HAMMER



Model No.	Mfg. No.	Jaw Opening""	Length"	Price /Each
TYQ437	900H	1 13/16	15	215.00

ADJUSTABLE HEAD PIN SPANNER WRENCHES



Model No.	Mfg. No.	Diameter Range"	Length"	Pin Diameter"	Price /Each
TYQ459	APS2	3/4 - 2	6 3/8	1/8	79.50
TYQ460	APS21	3/4 - 2	6 3/8	3/16	79.50
TYQ461	APS3	1 1/4 - 3	8 1/8	3/16	95.90
TYQ462	APS31	1 1/4 - 3	8 1/8	1/4	98.90
TYQ463	APS4	2 - 4 3/4	11 3/8	1/4	119.00
TYQ464	APS6	4 1/2 - 6 1/4	12 1/8	3/8	129.00

STRUCTURAL WRENCHES - OFFSET HEAD



Model No.	Mfg. No.	Hex Size"	Length"	Price /Each
TYQ444	903A	5/8	12	50.90
TYQ445	904A	3/4	12	51.90
TYQ438	905	7/8	14.5	63.90
NJH095	906	15/16	14.5	68.90
TYQ446	906B	1	14.5	72.50
TYQ439	907	1 1/16	16	77.50
TYQ447	907A	1 1/8	16	83.90

Model No.	Mfg. No.	Hex Size"	Length"	Price /Each
TYQ440	908	1 1/4	18	97.50
TYQ448	908A	1 5/16	19	115.00
TYQ441	909	1 7/16	20	135.00
TYQ449	909A	1 1/2	20	145.00
TYQ442	910	1 5/8	20	185.00
TYQ443	912	2	24	285.00

STRUCTURAL ADJUSTABLE WRENCH



Model No.	Mfg. No.	Overall Length"	Capacity"	Price /Each
TYQ419	900	15	1 3/4	209.00

SUPER HEAVY-DUTY PROFESSIONAL ADJUSTABLE WRENCH

- Ergonomic handle increases comfort, gripping power and reduces user fatigue
- Precision ground jaws grip fasteners better, reducing rounding
- Thin jaw design provides better access to confined spaces
- S.A.E. and metric scales for quick and accurate adjustments
- All components made of finest quality Chrome Vanadium steel
- Finish: Plain
- Handle Type: Plain
- Standard(s) Met: CDA 39-GP-13A, GGG-W-631B, ANSI
- Material: CrV



Model No.	Mfg. No.	Overall Length"	Capacity"	Price /Each
AUW073	711139	24	2-3/4	342.00

ADJUSTABLE CONSTRUCTION WRENCH

- Drop forged steel heat treated for maximum strength and professional use
- Offset design allows clearance over work
- Round tapered stock allows use as aligning bar
- Black oxide finish resists corrosion and provides improved grip for safer use
- Adjustable up to 1-5/8" for maximum convenience
- Eliminates the need to carry multiple wrenches
- Tapered shaft aids in aligning bolt holes
- Continuous taper reduces binding
- Precisely ground jaws remain parallel at all opening widths for better grip
- Ultra smooth acting knurl for fast adjustment
- Flat neck allows use of lanyard for added safety
- Finish: Black Oxide
- Handle Type: Plain
- Standard(s) Met: GGG-W-636E
- Taper: 1-1/8" - 3/16"



Model No.	Mfg. No.	Length"	Size"	Head Thickness"	Head Width"	Price /Each
AUW074	711146	15-3/4	1-5/8	5/8	3-1/2	95.70

ADJUSTABLE WRENCHES



Model No.	Mfg. No.	Length"	Max. Jaw Width"	Price /Each
CHROME FINISH				
VE032	AC24VS	4	1/2	17.60
VE033	AC26VS	6	15/16	18.80
VE034	AC28VS	8	1 1/8	21.30
VE035	AC210VS	10	1 5/16	27.60
VE036	AC212VS	12	1 1/2	31.30
CUSHION GRIP, CHROME FINISH				
VE040	AC24CVS	4	1/2	18.80

Model No.	Mfg. No.	Length"	Max. Jaw Width"	Price /Each
BLACK PHOSPHATE FINISH				
VE046	AT14V	4	1/2	18.80
VE047	AT16V	6	15/16	21.30
VE048	AT18V	8	1 1/8	23.80
VE049	AT110V	10	1 5/16	30.10
VE050	AT112V	12	1 1/2	33.90
CUSHION GRIP, BLACK PHOSPHATE FINISH				
VE055	AT18CV	8	1 1/8	27.60
VE057	AT212CVS	12	1 1/2	38.90

*Tapered handle

ADJUSTABLE WRENCHES

- Superior grade chrome vanadium steel
- Precision machined jaws
- Slim profile head slips into cramped quarters
- Tight tolerances ensure close fitting, wobble-free action
- Smooth, non-sticking mechanism
- Black nickel finish resists rust
- Meets ANSI standards



Model No.	Length"	Max. Jaw Width"	Description	Price /Each
TJZ100	6	1	Standard jaw, composite body	13.15
TJZ101	8	1 1/4	Reversible jaw, composite body	16.85
TJZ102	10	1 3/8	Reversible jaw, composite body	23.95
TJZ103	12	1 5/8	Reversible jaw, composite body	27.10
TJZ104	15	1 3/4	Standard jaw, steel body	55.00
TJZ105	18	2 1/4	Standard jaw, steel body	95.00

6-PIECE ADJUSTABLE WRENCH SETS

- Kit includes: TJZ100, TJZ101, TJZ102, TJZ103, TJZ104 and TJZ105

Model No. TLZ796
Price/Each \$219.00

COMBINATION WRENCHES

- Chrome vanadium steel for strength and durability
- Heat treated for consistent hardness
- Precision broached jaws for sure gripping
- 12-point box end for snug fit
- Thin walled construction for access in cramped quarters
- Meets ANSI standards



Model No.	Size"	Length"	Price /Each
SAE			
TYK599	1/4	4	2.25
TYK600	5/16	4 3/4	2.25
TYK601	11/32	4 1/4	2.45
TYK602	3/8	5 1/4	2.40
TYK603	7/16	6	2.80
TYK604	1/2	6 3/4	3.10
TYK605	9/16	7	3.40
TYK606	5/8	8	3.80
TYK607	11/16	8 11/16	4.15
TYK608	3/4	9	5.35
TYK609	13/16	9 15/16	5.85
TYK610	7/8	10 1/4	7.60
TYK611	15/16	11 1/2	8.75
TYK612	1	11 3/4	10.25
TYK613	1 1/16	12	11.65
TYK614	1 1/8	12 1/2	13.35
TYK615	1 1/4	13 3/4	15.70

Model No.	Size mm	Length mm	Price /Each
METRIC			
TYK616	6	102	1.95
TYK617	7	121	2.10
TYK618	8	131	2.25
TYK619	9	141	2.55
TYK620	10	151	2.70
TYK621	11	151	2.80
TYK622	12	161	3.05
TYK623	13	171	3.10
TYK624	14	181	3.15
TYK625	15	191	3.80
TYK626	16	201	4.50
TYK627	17	211	4.65
TYK628	18	221	5.35
TYK629	19	231	5.65
TYK630	20	241	6.15
TYK631	21	252	6.60
TYK632	22	261	7.45
TYK633	23	275	7.75
TYK634	24	292	8.75
TYK635	25	300	10.15
TYK636	26	300	10.40
TYK637	27	323	12.20
TYK638	28	323	12.90
TYK639	29	345	13.35
TYK640	30	345	14.35
TYK641	32	373	15.70

COMBINATION WRENCH SETS

- Chrome vanadium steel for strength and durability
- Heat treated for consistent hardness
- Precision broached jaws for sure gripping
- 12-point box end for snug fit
- Thin walled construction for access in cramped quarters
- Meets ANSI standards



Model No.	Description	Price/Each
TLV053	11 SAE Combination Wrenches: 1/4", 5/16", 3/8", 7/16", 1/2", 9/16", 5/8", 11/16", 3/4", 13/16", 7/8"	39.95
TLV054	11 Metric Combination Wrenches: 7 mm, 8 mm, 9 mm, 10 mm, 11 mm, 12 mm, 13 mm, 14 mm, 15 mm, 17 mm, 19 mm	39.95
TLV055	14 SAE Combination Wrenches: 3/8", 7/16", 1/2", 9/16", 5/8", 11/16", 3/4", 13/16", 7/8", 15/16", 1", 1 1/16", 1 1/8", 1 1/4"	88.85
TLV056	14 Metric Combination Wrenches: 10 mm, 12 mm, 13 mm, 14 mm, 15 mm, 16 mm, 17 mm, 18 mm, 19 mm, 22 mm, 24 mm, 27 mm, 30 mm, 32 mm	88.85

RATCHETING COMBINATION WRENCHES

- Chrome vanadium steel for strength and durability
- Ratcheting head allows for faster removal and installation of fasteners
- 72-tooth ratchet gear
- 12-point box end for snug fit
- Needs as little as 5 degrees to move a fastener
- Meets ANSI standards



AURORA
TOOLS

Model No.	Size"	Length"	Price /Each
SAE			
UAD652	5-1/4	1/4	14.85
UAD653	5/16	5-1/4	16.25
UAD654	3/8	6-1/4	17.65
UAD655	7/16	6-1/2	18.95
UAD656	1/2	7	21.60
UAD657	9/16	7-7/16	22.95
UAD658	5/8	8-1/16	25.55
UAD659	11/16	8-13/16	26.95
UAD660	3/4	9-11/16	29.70
UAD661	13/16	11	40.50
UAD662	7/8"	11	44.15
UAD663	15/16	12-3/16	44.85
UAD664	1	12-3/16	44.95

Model No.	Size mm	Length mm	Price /Each
METRIC			
UAD665	7	134	12.95
UAD635	8	134	14.90
UAD636	9	158.5	16.30
UAD637	10	158.5	17.70
UAD638	11	164.6	18.80
UAD639	12	167.7	20.25
UAD640	13	177.4	21.65
UAD641	14	189.5	23.05
UAD642	15	198	24.40
UAD643	16	205.4	25.80
UAD644	17	224	26.95
UAD645	18	235.4	28.35
UAD646	19	246.4	29.75

COMBINATION FIXED HEAD RATCHETING WRENCH SETS

- Set includes a roll pouch and ratchet wrenches
- Ratcheting heads allow for faster removal and installation of fasteners
- Wrench's feature 72-tooth ratchet gear & 12-point box end for snug fit
- Meets ANSI standards



TEQ832



TEQ835

AURORA
TOOLS

Model No.	No. of Pieces	Includes	Price /Each
SAE			
TEQ832	8	5/16", 3/8", 7/16", 1/2", 9/16", 5/8", 11/16", 3/4"	110.00
TEQ833	13	1/4", 5/16", 3/8", 7/16", 1/2", 9/16", 5/8", 11/16", 3/4", 13/16", 7/8", 15/16", 1"	230.00
METRIC			
TEQ834	8	8 mm, 10 mm, 12 mm, 13 mm, 14 mm, 15 mm, 16 mm, 18 mm	110.00
TEQ835	13	7 mm, 8 mm, 9 mm, 10 mm, 11 mm, 12 mm, 13 mm, 14 mm, 15 mm, 16 mm, 17 mm, 18 mm, 19 mm	170.00

REVERSIBLE RATCHETING WRENCH SETS

- One-finger operated compact reversible lever – No side push pin
- 15° offset provides additional knuckle clearance



GW GEARWRENCH

Model No.	TDS860	TDS816	TGZ813
Mfg. No.	9533N	9620N	9602N
	8 pcs. SAE 5/16" – 3/4"	12 pcs. metrics 8 mm – 19 mm	16 pcs. metrics 8 mm – 25 mm
Price/Each	\$146.00	\$167.00	\$300.00

COMBINATION RATCHETING WRENCH SETS

- Surface Drive® nearly eliminates fastener rounding
- Exceed ANSI box-end strength requirement
- Forged metal
- Mirror chrome finish
- 5° ratcheting box end



GW GEARWRENCH

Model No.	TDS803	TDS792	TDS903	TDS904	TDS842
Mfg. No.	9312	9416	9317	9417	9412
	13 pcs. SAE 1/4" – 1"	16 PCS. metrics 8 mm – 24 mm	7 pcs. SAE 5/16" – 3/4"	7 pcs. metrics 8 mm – 18 mm	12 pcs. metrics 8 mm – 19 mm
Price/Each	\$180.00	\$188.00	\$67.00	\$67.00	\$120.00

XL: EXTRA LONG HIGH PERFORMANCE COMBINATION

- Up to 25% longer for more leverage
- Surface Drive Plus™ - patented anti-spread open end
- Ability to apply more torque
- Minimize fastener rounding
- Oval shaped handle



GW GEARWRENCH

Model No.	TGZ822	TGZ823
Mfg. No.	85199	85099
	13 pcs. SAE 1/4" – 1"	16 pcs. metrics 8 mm – 24 mm
Price/Each	\$340.00	\$400.00

FLEXIBLE RATCHETING WRENCH SETS

- Flex Head: Tilts up to 180° at any interval
- Spring washer design: providing continuous head tension
- One touch direction assistant



GW GEARWRENCH

Model No.	TGZ814	TGZ815	TDS843	TDS844	TDS793
Mfg. No.	9702D	9902D	9700	9900D	9901D
	13 pcs. SAE 5/16" – 1"	16 pcs. metrics 8 mm – 24 mm	7 pcs. SAE 3/8" – 3/4"	7 pcs. metrics 10 mm – 19 mm	12 pcs. metrics 8 mm – 19 mm
Price/Each	\$285.00	\$351.00	\$121.00	\$121.00	\$221.00

WRENCHES

12-POINT SAE ROUND SHANK LARGE COMBINATION WRENCHES - 15° OFFSET



Model No.	Mfg. No.	Hex Size"	Length"	Price /Each
TJ990	3150	1 9/16	24	149.00
TJ991	3152	1 5/8	24	155.00
TJ992	3154	1 11/16	24	159.00
TJ993	3156	1 3/4	24	169.00
TJ994	3158	1 13/16	28	185.00
TJ995	3160	1 7/8	28	219.00
TJ996	3162	1 15/16	28	225.00
TJ997	3164	2	28	235.00
TJ998	3166	2 1/16	30	275.00
TJ999	3168	2 1/8	30	309.00
TI001	3170	2 3/16	30	315.00
TI002	3172	2 1/4	30	339.00
TI003	3174	2 5/16	30.5	349.00
TI004	3176	2 3/8	30.5	369.00
TI005	3178	2 7/16	30.5	369.00
TI006	3180	2 1/2	30.5	379.00
TI007	3182	2 9/16	31	615.00
TI008	3184	2 5/8	31.5	625.00
TI009	3186	2 11/16	32	629.00
TI010	3188	2 3/4	32.5	635.00
TYQ079	3190	2 13/16	33	745.00
TYQ080	3192	2 7/8	33.5	765.00
TYQ081	3194	2 15/16	34	775.00
TYQ082	3196	3	34.5	775.00
TYQ083	3198	3 1/16	35	789.00
TYQ084	3200	3 1/8	35.5	795.00
TYQ098	3304	3 1/4	36	1035.00
TYQ099	3308	3 3/8	36.5	1049.00
TYQ100	3312	3 1/2	37	1085.00
TYQ101	3316	3 5/8	37.5	1179.00
TYQ102	3320	3 3/4	38	1279.00
TYQ103	3324	3 7/8	38.5	1379.00
TYQ104	3328	4	39	1475.00

6 OR 12-POINT 25° OFFSET RATCHETING BOX WRENCHES



Model No.	Mfg. No.	Opening	Length	Price /Each
SAE				
TYR610*	5201	1/4" x 5/16"	4 1/4"	30.90
TYR611*	5202	3/8" x 7/16"	5 1/4"	34.50
QC751*	5203	1/2" x 9/16"	6 3/4"	41.90
TYR613	5204	5/8" x 11/16"	8"	48.50
TYR614	5205	3/4" x 7/8"	9 1/4"	55.50
TYR616	5207	5/8" x 3/4"	8"	55.90
METRIC				
TYR643*	MROB78	7 mm x 8 mm	108 mm	30.90
TYR644*	MROB910	9 mm x 10 mm	140 mm	34.90
TYR640*	MROB1112	11 mm x 12 mm	171 mm	39.50
TYR641*	MROB1314	13 mm x 14 mm	171 mm	42.50
TYR642	MROB1517	15 mm x 17 mm	203 mm	44.50

* 6 Points

OPEN END WRENCHES - 15° HEAD ANGLE



Model No.	Mfg. No.	Opening	Length	Price /Each
SAE				
TYQ244	E68	3/16" x 1/4"	3.87"	18.50
TYQ245	E810	1/4" x 5/16"	4.5"	18.50
TYQ232	E1012	5/16" x 3/8"	5.12"	18.50
TYQ233	E1214	3/8" x 7/16"	5.75"	18.50
TYQ234	E1416	7/16" x 1/2"	6.37"	18.90
TYQ235	E1618	1/2" x 9/16"	7"	19.50
TYQ236	E1820	9/16" x 5/8"	7.62"	25.90
TJ132	E1922	19/32" x 11/16"	8.25"	28.90
TYQ237	E2022	5/8" x 11/16"	8.25"	29.90
TYQ238	E2024	5/8" x 3/4"	8.25"	29.90
TYQ239	E2224	11/16" x 3/4"	8.37"	31.50
TYQ240	E2428	3/4" x 7/8"	9.5"	38.90
TYQ241	E2628	13/16" x 7/8"	10.12"	43.50
TYQ242	E3032	15/16" x 1"	11.37"	61.90
TYQ243	E3440	1 1/16" x 1 1/4"	13.56"	81.90
METRIC				
TYQ256	ME67	6 mm x 7 mm	114 mm	18.50
TYQ257	ME89	8 mm x 9 mm	130 mm	18.90
TE502	ME810	8 mm x 10 mm	130 mm	19.50
TYQ246	ME1011	10 mm x 11 mm	146 mm	20.90
TYQ247	ME1213	12 mm x 13 mm	161 mm	22.50
TYQ248	ME1415	14 mm x 15 mm	193 mm	24.90
TYQ249	ME1617	16 mm x 17 mm	209 mm	30.90
TYQ250	ME1819	18 mm x 19 mm	225 mm	35.90
TYQ251	ME2021	20 mm x 21 mm	241 mm	44.90
TYQ252	ME2122	21 mm x 22 mm	257 mm	51.50
TYQ253	ME2427	24 mm x 27 mm	320 mm	61.90
TYQ254	ME2528	25 mm x 28 mm	320 mm	72.50
TYQ255	ME2732	27 mm x 32 mm	344 mm	82.50

METRIC CHROME FLARE NUT WRENCHES - 15° OFFSET



Model No.	Mfg. No.	Opening mm	Length mm	Price /Each
TYQ382	FL0911M	9 mm x 11 mm	152 mm	31.50
TYQ383	FL1012M	10 mm x 12 mm	152 mm	36.90
TYQ385	FL1314M	13 mm x 14 mm	178 mm	36.90
TYQ386	FL1517M	15 mm x 17 mm	196 mm	43.90
TYQ387	FL1618M	16 mm x 18 mm	202 mm	44.50

SAE CHROME FLARE NUT WRENCHES - 15° OFFSET



Model No.	Mfg. No.	Opening"	Length"	Price /Each
TYQ384	FL1214S	3/8 x 7/16	6	29.90
TYQ388	FL1618S	1/2 x 9/16	7	36.50
TYQ389	FL2022S	5/8 x 11/16	7.75	42.90

6-POINT BOX END WRENCHES 15° OFFSET



Model No.	Mfg. No.	Opening	Length	Price /Each
SAE				
YA980	2840	3/8" x 7/16"	8"	29.50
TYQ259	2843	1/2" x 9/16"	9.5"	29.90
TYQ260	2846	5/8" x 11/16"	10.5"	35.90
TYQ262	2852	13/16" x 7/8"	13"	41.90
YA981	2855	15/16" x 1"	15.46"	71.90
METRIC				
TYQ371	MB89	8 mm x 9 mm	188 mm	25.90
TYQ376	MB1011	10 mm x 11 mm	205 mm	25.90
TYQ377	MB1213	12 mm x 13 mm	227 mm	26.50
TYQ378	MB1415	14 mm x 15 mm	257 mm	29.50
TYQ379	MB1719	17 mm x 19 mm	305 mm	36.90
TYQ380	MB2022	20 mm x 22 mm	330 mm	43.90

12-POINT WRENCHES METRIC STUBBY COMBINATION WRENCHES - 15° OFFSET



Model No.	Mfg. No.	Opening mm	Length mm	Price /Each
TYQ114	64206	6	76	22.90
TYQ115	64207	7	76	22.90
TYQ116	64208	8	83	23.50
TYQ117	64209	9	106	23.90
TYQ118	64210	10	127	24.90
TYQ119	64211	11	127	24.90
TYQ120	64212	12	133	24.90
TYQ121	64213	13	133	24.90
TYQ122	64214	14	146	27.90
TYQ123	64215	15	146	27.90
TYQ124	64216	16	155	29.90
TYQ125	64217	17	165	30.90
TYQ126	64218	18	165	33.50
TYQ127	64219	19	171	36.90

SAE STUBBY COMBINATION WRENCHES - 15° OFFSET



Model No.	Mfg. No.	Opening"	Length"	Price /Each
TYQ105	63208	1/4	3	21.50
TYQ106	63210	5/16	3.25	21.50
TYQ107	63212	3/8	4.18	21.50
TYQ108	63214	7/16	5	22.90
TYQ109	63216	1/2	5.25	23.50
TYQ110	63218	9/16	5.75	24.50
TYQ111	63220	5/8	6.12	25.50
TYQ112	63222	11/16	6.5	29.90
TYQ113	63224	3/4	16.75	32.90

SAE FLAT RATCHETING BOX WRENCHES



Model No.	Mfg. No.	Opening"	Length"	Price /Each
6-POINT				
UQ113	5001	1/4 x 5/16	4 1/4	24.50
QC677	5002	3/8" x 7/16	5 1/4	26.50
TYR603	5003	1/2 x 9/16	6 3/4	33.50
12-POINT				
TYR632	5001T	1/4 x 5/16	4 1/4	25.90
TYR633	5003T	1/2 x 9/16	6 3/4	35.50
TYR604	5004	5/8 x 7/16	5 1/4	39.50
TYR605	5005	3/4 x 7/8	6 3/4	44.90
TYR606	5006	5/8 x 3/4	5 1/4	47.50
TYR607	5007	13/16 x 15/16	6 3/4	53.90
TYR608	5008	1 x 1 1/16	5 1/4	115.00
TYR609	5009	1 1/8 x 1 1/4	6 3/4	115.00

SAE FLAT RATCHETING BOX WRENCHES 12-POINT



Model No.	Mfg. No.	Opening"	Length"	Price /Each
TYR617	50042	1 5/16	15.5	205.00
TYR618	50044	1 3/8	15.5	209.00
TYR619	50046	1 7/16	15.5	209.00
TYR620	50048	1 1/2	15.5	215.00
TYR621	50050	1 9/16	15.5	215.00
TYR622	50052	1 5/8	15.5	215.00
TYR623	50054	1 11/16	19	245.00
TYR624	50056	1 3/4	19	249.00
TYR625	50058	1 13/16	19	259.00
TYR626	50060	1 7/8	19	269.00
TYR627	50064	2	19	285.00
TYR628	50068	2 1/8	19	295.00

METRIC FLAT RATCHETING BOX WRENCHES



Model No.	Mfg. No.	Opening mm	Length"	Price /Each
6-POINT				
TYR638	MRB78	7 x 8	108	23.90
TYR639	MRB910	9 x 10	140	27.50
TYR635	MRB1112	11 x 12	171	38.90
TYR636	MRB1314	13 x 14	171	41.50
12-POINT				
TYR637	MRB1517	15 x 17	203	42.50

GEARED COMBINATION WRENCH SETS



11-PC. METRIC FIXED HEAD GEARED

- Kit contains wrenches from 8 mm to 19 mm
- Includes organizer

Model No. TYP335
Mfg. No. 59711A
Price/Each \$429.00

8-PC. SAE FIXED HEAD GEARED

- Kit contains wrenches in the following sizes: 5/16", 3/8", 7/16", 1/2", 9/16", 5/8", 11/16", 3/4"
- Includes organizer

Model No. TYP334
Mfg. No. 59708A
Price/Each \$315.00

COMBINATION WRENCH SETS



14-PC. 12-POINT SAE MIRROR CHROME

- Kit contains wrenches in the following sizes: 3/8", 7/16", 1/2", 9/16", 5/8", 11/16", 3/4", 13/16", 7/8", 15/16", 1", 1 1/16", 1 1/8", 1 1/4"
- Includes organizer

Model No. QE318
Mfg. No. TU145
Price/Each \$755.00

14-PC. 12-POINT METRIC MIRROR CHROME

- Kit contains wrenches from 7 mm to 32 mm
- Includes organizer

Model No. TYP354
Mfg. No. MC214
Price/Each \$765.00

7 PC. 12-POINT SAE MIRROR CHROME

- Kit contains wrenches in the following sizes: 7/16", 1/2", 9/16", 5/8", 11/16", 3/4", 7/8"
- Includes organizer

Model No. TYP374
Mfg. No. TU7
Price/Each \$775.00

14-PC. 12-POINT METRIC STUBBY MIRROR CHROME

- Kit contains wrenches from 6 mm to 19 mm
- Includes organizer

Model No. TYP324
Mfg. No. 64814
Price/Each \$409.00

9-PC. 12-POINT SAE STUBBY MIRROR CHROME

- Kit contains wrenches in the following sizes: 1/4", 5/16", 3/8", 7/16", 1/2", 9/16", 5/8", 11/16", 3/4"
- Includes organizer

Model No. TYP319
Mfg. No. 63809
Price/Each \$249.00

RATCHETING STUBBY WRENCH SET

- 12-point box ends for superior grip
- 72-tooth ratchet mechanism exceeds the ANSI torque ratings for a fixed wrench by more than 30%
- Superior grade 6140 Chrome Vanadium steel
- Flat style allows maximum access to confined areas – just flip wrench over to reverse
- Fully polished surface resists corrosion
- Complete with Terylene Pouch
- No. of Points: 12
- Finish: Polished
- Handle Type: Plain



Model No.	Mfg. No.	No. of Pieces	Includes	Price /Each
METRIC				
AUW059	700302	10	10 mm, 11 mm, 12 mm, 13 mm, 14 mm, 15 mm, 16 mm, 17 mm, 18 mm, 19 mm	219.00

WRENCHES

JUMBO WRENCH SET

- Industrial quality drop forged chrome vanadium steel
- Heat treated for professional use
- Raised panel for increased strength
- Chrome plated for corrosion resistance
- Type: Combination
- Includes: Terylene Roll Pouch



Model No.	Mfg. No.	Description	Price/Each
UAV822	020203	10 Metric Combination Wrenches: 33, 35, 36, 38, 41, 43, 44, 46, 48, 50 mm	399.00

POLISHED WRENCH SET

- Drop forged heat treated chrome vanadium steel
- Precision machined open and box ends
- Box ends feature anti-rounding design to prevent fastener damage
- Nickel Chrome finish resists corrosion
- Meets ANSI standards
- Type: Combination
- Includes: Roll Pouch



Model No.	Mfg. No.	Description	Price/Each
UAV823	020210	14 SAE Combination Wrenches: 3/8, 7/16, 1/2, 9/16, 5/8, 11/16, 3/4, 13/16, 7/8, 15/16, 1, 1-1/16, 1-1/8, 1-1/4"	80.90
UAV824	020211	14 Metric Combination Wrenches: 10, 11, 13, 14, 15, 16, 17, 18, 19, 21, 22, 24, 27, 32 mm	80.90

OFFSET STRIKING WRENCH

- Drop forged steel heat treated for maximum strength
- Offset design allows clearance over work and raises striking surface above ground level
- Flat design gets into tight spaces where offset wrenches cannot reach
- 12-point design allows for twice the number of positions for improved indexing
- Black oxide finish resists corrosion and provides improved grip for safer use
- No. of Points: 12
- Handle Type: Plain
- Standard(s) Met: GGG-W-636E, ANSI B107.100-2010



Model No.	Mfg. No.	Length"	Size"	Head Thickness"	Head Width"	Price /Each
AUW075	715205	11-7/16	1-1/4	29/32	2-3/32	105.00
AUW076	715209	12-5/8	1-1/2	1-1/32	2-5/8	119.00
AUW077	715211	12-5/8	1-5/8	1-1/32	2-5/8	128.00
AUW078	715214	13-3/8	1-13/16	1-1/16	2-7/8	144.00
AUW079	715215	13-3/8	1-7/8	1-1/16	2-7/8	151.00
AUW080	715217	13-3/4	2	1-1/4	3-1/16	164.00
AUW081	715223	14-3/4	2-3/8	1-3/8	3-17/32	232.00
AUW082	715227	15-3/8	2-5/8	1-1/2	3-25/32	259.00

ADJUSTABLE WRENCH SET

- Professional quality
- Drop forged Chrome Vanadium steel
- Fully heat treated for strength and durability
- Accurately machined sliding jaw for smooth adjustment
- Traditional handle design
- Size Standard: Imperial and Metric
- Material: CrV



Model No.	Mfg. No.	No. of Pieces	Includes	Price /Each
AUW071	711102	3	8" (160 mm), 10" (210 mm), 12" (300 mm) Openings: 1", 1-1/4", 1-1/2"	69.70

LONG REVERSIBLE RATCHETING COMBINATION WRENCH SET

- Exclusive Torque Drive® non-slip open ends
- 72-tooth ratchet mechanism exceeds the ANSI torque ratings for a fixed wrench by more than 30%
- Superior grade 6140 Chrome Vanadium steel
- Fully polished surface resists corrosion
- Sets complete with plastic carrying rack
- Features a reversing lever
- Allows 15° offset for clearance
- Low profile lever does not add height to the box end, maintaining clearance
- Rated at 1.2x ANSI torque values
- Finish: Polished
- Handle Type: Plain



Model No.	Mfg. No.	No. of Pieces	Includes	Price /Each
SAE				
AUW060	700321	8	5/16", 3/8", 7/16", 1/2", 9/16", 5/8", 11/16", 3/4"	232.00
METRIC				
AUW061	700372	12	7 mm, 8 mm, 9 mm, 10 mm, 11 mm, 12 mm, 13 mm, 14 mm, 15 mm, 16 mm, 17 mm, 18 mm, 19 mm	342.00

FLEX HEAD RATCHET COMBINATION WRENCH SET

- Exclusive Torque Drive® non-slip open ends
- 72-tooth ratchet mechanism exceeds the ANSI torque ratings for a fixed wrench by more than 30%
- Superior grade 6140 Chrome Vanadium steel
- Fully polished surface resists corrosion
- Sets complete with plastic carrying rack
- Flex head design allows up to 180° flex for increased access to confined areas
- Light tension holds position while allowing easy adjustment of angle
- Finish: Polished
- Handle Type: Plain



Model No.	Mfg. No.	No. of Pieces	Includes	Price /Each
METRIC				
AUW062	700381	11	8 mm, 9 mm, 10 mm, 11 mm, 12 mm, 13 mm, 14 mm, 15 mm, 17 mm, 18 mm, 19 mm	391.00

SCREWDRIVERS & NUTDRIVERS

INDIVIDUAL SCREWDRIVERS





- Industrial quality and strength
- Chrome vanadium steel blade
- Treated blade tip for a lifetime of performance
- Extra large ergonomic handle for maximum torque and comfort
- Screwdriver type indication on the base of the grip
- Colour-coded handle for square type
- Meets ANSI standards



AURORA
TOOLS

Screwdriver type indication on the base of the grip. (Colour-coded handle for square type.)



Model No.	Tip Width"	Blade Length"	Price /Each
SLOT ELECTRICIANS			
 TJZ057	1/8	3	2.85
TJZ058	3/16	4	3.45
TJZ059	3/16	6	4.10
SLOT MECHANICS			
 TJZ060	1/4	1 1/2 Stubby	3.40
TJZ061	1/4	4	4.15
TJZ062	1/4	5	4.40
TJZ063	1/4	6	4.90
TJZ064	5/16	6	6.60
TJZ065	3/8	8	7.55
PHILLIPS TIP			
	Tip Number		
 TJZ066	#0	2 1/2	2.85
TJZ067	#1	3 1/4	3.55
TJZ068	#2	4	4.15
TJZ070	#3	6	6.10
TJZ069	#2	1 1/2 Stubby	3.40
SQUARE TIP			
	Tip Number		
 TJZ071	#0	4	4.15
TJZ072	#1	4	4.80
TJZ073	#2	6	5.55
TJZ074	#3	6	6.50
TJZ075	#1	1 1/2 Stubby	3.25
TJZ076	#2	1 1/2 Stubby	3.45
TJZ077	#3	1 1/2 Stubby	3.45



SCREWDRIVER SETS



AURORA
TOOLS

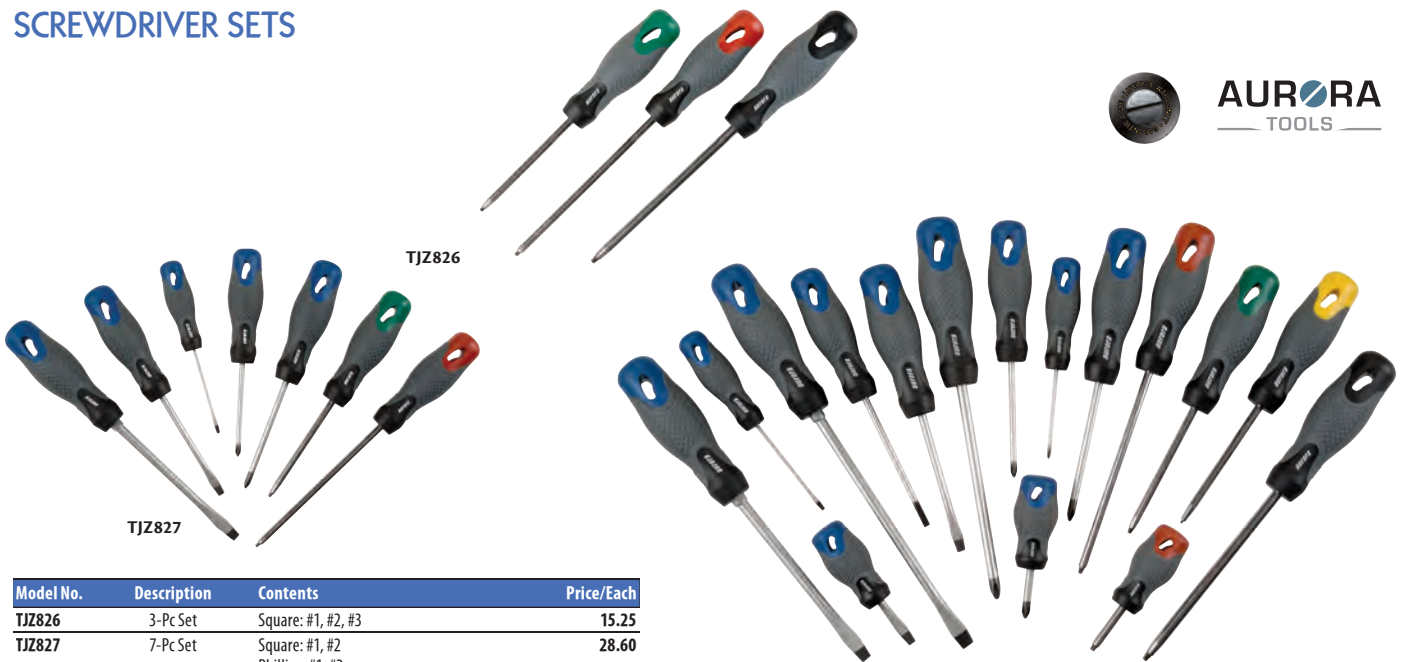

Model No.	Description	Contents	Price/Each
TJZ826	3-Pc Set	Square: #1, #2, #3	15.25
TJZ827	7-Pc Set	Square: #1, #2 Phillips: #1, #2 Flat: 1/8", 1/4", 5/16"	28.60
TJZ828	16-Pc Set	Square: #0, #1, #2, #3, #2 Stubby Phillips: #0, #1, #2, #3, #2 Stubby Flat: 1/8", 3/16", 1/4", 5/16", 3/8", 1/4" Stubby	62.80

SCREWDRIVERS & NUTDRIVERS



CUSHION-GRIP SCREWDRIVERS

Klein® screwdrivers are made of the highest quality materials. Designed for the serious industrial user, these screwdrivers are the standard. Featuring cushion grip for user comfort and durability. Chrome plated shank and heat treated tip insure long life. Grip is resistant to gas, oil and water.



A. HEAVY-DUTY SQUARE SHANK, SLOT KEYSTONE TIP

Model No.	Mfg. No.	Tip Width"	Shank Length"	Price /Each
TV501	600-4	1/4	4	20.20
TV502	600-6	5/16	6	22.90
TV503	600-8	3/8	8	31.70
TV504	600-12	1/2	12	38.10

B. HEAVY-DUTY ROUND SHANK, SLOT KEYSTONE TIP

Model No.	Mfg. No.	Tip Width"	Shank Length"	Price /Each
TV505	602-3	7/32	3	17.70
TV506	602-4	1/4	4	17.70
TV507	602-6	5/16	6	22.80
TV508	602-8	3/8	8	29.10
TV509	602-10	3/8	10	34.30
TV510	602-12	3/8	12	37.90

C. HEAVY-DUTY ROUND SHANK, SLOT CABINET TIP

Model No.	Mfg. No.	Tip Width"	Shank Length"	Price /Each
TV511	605-4	1/4	4	16.50
TV512	605-6	1/4	6	17.80
TV513	605-8	1/4	8	21.50
TV514	605-10	1/4	10	24.00

D. ROUND SHANK, SLOT CABINET TIP

Model No.	Mfg. No.	Tip Width"	Shank Length"	Price /Each
TV500*	600-1	5/16	1 1/2	14.10
TV515	601-3	3/16	3	15.20
TV516	601-4	3/16	4	15.20
TV517	601-6	3/16	6	15.20
TV518	601-8	3/16	8	17.70
TV519	601-10	3/16	10	20.20

*Stubby

G. ROUND SHANK, TORX® TIP

Model No.	Mfg. No.	Tip No.	Shank Length"	Price /Each
TV533	19542	T15	4	15.30
TV534	19543	T20	4	15.30
TV535	19544	T25	4	15.30
TV536	19545	T27	4	15.30
TV537	19546	T30	4	15.30

J. CONDUIT FITTING & REAMING SCREWDRIVER

- Hood over tip keeps the tip from slipping out of the screws especially when working overhead
- Conduit reamer will accommodate 1/2", 3/4", 1" thin wall conduit
- Reamer part is replaceable

Model No.	Mfg. No.	Tip Width"	Shank Length"	Price /Each
TJ880	85191	5/16	2 1/2	63.20

7-PIECE CANADIAN BASIC SETS

Set includes 1 each of the following:

- Square Tip: #1, #2, #3
- Phillips Tip: #1, #2
- Slot: 3/16", 1/4"

Model No. TJ881
Price/Each \$113.57



8-PIECE LONG & SHORT SETS

Set includes 1 each of the following:

- Square Tip: #2 (shank length 8")
- Phillips Tip: #2 (shank length 1-1/2"), #2 (shank length 10")
- Slot: 1/2" (shank length 12"), 3/8", 3/16", 1/4" (shank length 10"), 1/4" (shank length 1-1/2")

Model No. TJ882
Price/Each \$185.01



SCREWDRIVERS & NUTDRIVERS

8-PC. PRECISION SCREWDRIVER SET

- Rotating end cap for constant finger pressure when driving screws
- Cushioned non-slip handle
- Meets ANSI standards
- Limited lifetime warranty
- Contents:** Phillips No.: 00, 0, & 1 Slotted: 5/64", 3/32", 11/64", 9/64" & 5/32"
- Weight: 1 lbs.
- Overall Dimensions: 8" L x 5" W x 1-1/4" H
- Packaged in: Plastic Case

Model No. TYP978
Mfg. No. 86980
Price/Each \$80.90



8-PC. TORX® SCREWDRIVER SET

- Contents:** T5, T6, T7, T8, T9, T10, T15, T20
- Length: 6-1/2"

Model No. TYO424
Mfg. No. TXS800
Price/Each \$91.50



18-PC. PRECISION ULTRATECH™ SCREWDRIVER SETS

- Black oxide blades ensure a precision fit and prevent corrosion
- Eight sided cushion grip has a non-slip surface
- Close tolerance locking screw chuck holds blades securely in place
- Contoured fingertip swivel head allows greater pressure to be applied to the blade
- Packaged in a pocket sized fitted zipper case for secure storage
- Set includes:** 1 Versa-Grip multi-blade handle, 17 interchangeable blades: Slotted 3/64", 1/16", 5/64", 3/32", Phillips #000, #00, Torx® T6, T7, T8, T9, Hex 0.050, 1/16", 5/64", nut-drivers 3/32", 1/8", 5/32", awl/scribe.

Model No. TLZ550
Mfg. No. 063518
Price/Each \$47.49



10-PC. MINI SCREWDRIVER SETS

- Plated alloy steel blades ensure a long life
- Hardened tips and shafts ensure a maximum workload
- Set includes one each of the following sizes:**
Slotted: 3/64" x 1 1/2", 1/16" x 1 1/2", 5/64" x 1 1/2", 3/32" x 1 1/2";
Phillips: #000 x 1 1/2", #00 x 1 1/2", #0 x 1 1/2";
Torx: T6 x 1 1/2", T7 x 1 1/2", T8 x 1 1/2"

Model No. TLV308
Mfg. No. 022200
Price/Each \$44.89



HEAVY DUTY SCREWDRIVERS

- High visibility, oil and solvent resistant acetate handle
- Precision-machined tip for an exact fit
- Limited lifetime warranty**
- Meets ANSI standards



Model No.	Tip Size"	Shank Length"	Price /Each
SLOT WITH ROUND SHANK			
TYP579	1/8	1	4.19
TYP582	1/4	3	14.90
TYP583	1/4	4	14.90
TYP584	5/16	6	17.50
TYP585	3/8	8	20.90
TYP580	3/8	10	27.90
TYP581	1/8	12	28.50

Model No.	Tip Size"	Shank Length"	Price /Each
SLOT WITH SQUARE SHANK			
TYP598	1/4	3	12.50
TYP599	1/4	4	14.50
TYP600	5/16	6	19.50
TYP601	3/8	8	21.50
TYP595	1/2	10	21.90
TYP596	1/2	12	31.50
TYP597	9/16	18-1/2	63.90

Model No.	Tip Size	Shank Length"	Price /Each
PHILLIPS WITH ROUND SHANK			
TYP633	#0	2 3/8	10.50
TYP634	#1	3 1/4	12.50
TYP986	#2	4	98.50
TYP639	#3	6	21.90
TYP641	#4	8	25.50

SQUARE SCREWDRIVERS

- Heavy-duty triangle shaped comfort handles provide a secure grip and hand position needed to apply maximum torque
- Full-length blade goes through handle
- ID at top of the handle provides quick and convenient identification of type style
- Precision-machined tip for an exact fit
- Limited lifetime warranty**
- Meets ANSI standards



Model No.	Tip Size	Shank Length"	Price /Each
TYP620	#1	4	13.90
TY0415	#2	4	13.90
TYP622	#3	4	13.90

7-PC. PRECISION ULTRA TECH™ SCREWDRIVER SETS

SLOTTED, PHILLIPS & TORX®

- Set contains:** 1/16" slotted
3/32" slotted
1/8" slotted
#00 Phillips
#0 Phillips
#1 Phillips
Torx® T6

Model No. TLZ543
Price/Each \$43.49



SCREWDRIVERS & NUTDRIVERS



NUT DRIVER

- High visibility, oil and solvent resistant acetate handle
- Chrome finish for resistance against corrosion
- Accommodates long length bolts
- **Limited lifetime warranty**
- Meets ANSI standards



Model No.	Mfg. No.	Driver Size"	Overall Length"	Handle Colour	Price /Each
TYP666	CH06	3/16	6-3/4	Black	12.90
TYP669	CH08	1/4	6-3/4	Red	12.90
TYO418	CH11	11/32	6-5/8	Green	15.50
TYO419	CH12	3/8	6-5/8	Blue	15.50
TYO420	CH14	7/16	7	Brown	20.50

NUT DRIVER

- High visibility, oil and solvent resistant acetate handle
- Chrome finish for resistance against corrosion
- **Limited lifetime warranty**
- Meets ANSI standards



Model No.	Mfg. No.	Driver Size (mm)	Overall Length"	Handle Colour	Price /Each
TYP665	CH05	5	6-3/4	Amber	13.90
TYP667	CH06M	6	6-3/4	Amber	14.50
TYP668	CH07M	7	6-1/2	Amber	14.90
TYP670	CH08M	8	6-3/4	Amber	15.50
TYP671	CH09M	9	6-3/4	Amber	15.90
TYO417	CH10M	10	6	Amber	15.90
TYP672	CH11M	11	6-3/4	Amber	16.50

NUT DRIVER SET

- Contains: 3/16", 1/4", 5/16", 1/32", 3/8", 7/16", 1/2"
- Handle Type: Plastic
- Color-coded handles make for easy identification
- High visibility, oil and solvent resistant acetate handle
- Chrome finish for maximum resistance against corrosion
- No. of Pieces: 7
- Non Magnetic
- Drive Type: Imperial

Model No. QD538
Mfg. No. CHS7A
Price/Each \$125.00



7-PIECE NUT DRIVER SET

- No. of Pieces: 5,6,7,8,9,10,11
- Non Magnetic
- Drive Type: Metric

Model No. TYO421
Mfg. No. CHS7MA
Price/Each \$115.00



CUSHION GRIP NUT DRIVERS

- Handle caps are colour-coded for easy size identification
- Full hollow shaft permits turning nuts on long screws
- Chrome-plated shaft to help insure long life
- Available with or without magnetic tip



Size"	Shaft Length"	Colour Code	Model No.	Mfg. No.	Price /Each	Magnetic Model No.	Mfg. No.	Price /Each
3/16	3	Black	-	-	-	TLZ559	630-3/16M	17.80
1/4	3	Red	TV601	630-1/4	15.20	TBT557	630-1/4M	17.70
5/16	3	Yellow	TV602	630-5/16	14.60	TBT558	630-5/16M	19.00
11/32	3	Green	TV603	630-11/32	15.20	TLZ560	630-11/32M	20.30
3/8	3	Blue	TV604	630-3/8	15.20	TLZ561	630-3/8M	21.50
7/16	3	Brown	TV605	630-7/16	16.40	TLZ562	630-7/16M	24.00
1/2	3	Red	TV606	630-1/2	17.60	TLZ563	630-1/2M	25.40
9/16	4	Orange	TV607	630-9/16	22.80	-	-	-
5/8	4	Yellow	TV608	630-5/8	24.10	-	-	-
3/16	6	Black	TBT572	646-3/16	15.20	TLZ564	646-3/16M	19.10
1/4	6	Red	TBT569	646-1/4	15.10	TBT570	646-1/4M	20.30
5/16	6	Yellow	TBT574	646-5/16	15.30	TBT575	646-5/16M	21.50
11/32	6	Green	TBT571	646-11/32	15.30	TLZ565	646-11/32M	21.60
3/8	6	Blue	TBT573	646-3/8	16.50	TLZ566	646-3/8M	22.80
7/16	6	Brown	TBT577	646-7/16	17.80	TLZ567	646-7/16M	25.30
1/2	6	Red	TBT568	646-1/2	19.10	-	-	-
9/16	6	Orange	TBT578	646-9/16	24.00	-	-	-
5/8	6	Yellow	TBT576	646-5/8	26.60	-	-	-

7-PC CUSHION GRIP NUT DRIVER SETS

- Includes: 7 nut drivers from 3/16" to 1/2"
- Available with or without magnetic tip



3" SHAFTS
Model No. TV617
Mfg. No. 631
Price/Each \$98.50

Model No. TLZ570
Magnetic Tips
Mfg. No. 631M
Price/Each \$139.00

6" SHAFTS
Model No. TBS773
Mfg. No. 647
Price/Each \$108.00

Model No. TLZ569
Magnetic Tips
Mfg. No. 647M
Price/Each \$152.00



7/16" METRIC HEX POWER BITS



Model No.	Mfg. No.	Point Size mm	Overall Length"	Price /Each
UAV772	AN-5MM	5	3-1/2	27.10
UAV773	AN-6MM	6	3-1/2	27.10
UAV769	AN-8MM	8	3-1/2	27.10
UAV771	AN-10MM	10	3-1/2	27.10
UAV770	AN-14MM	14	3-1/2	27.10

HEX KEY SET

- Packaged in: Metal Case
- Made of premium steel for superior durability and corrosion resistance
- Deliver up to 33% more torque than ordinary hex keys
- Keys 1/8" & 3mm and larger have size permanently laser marked on the key



Model No.	Mfg. No.	Contains Sizes	No. of Keys	Drive Type	Price /Each
TYQ011	698115	0.028", 0.035", 1/2", 1/16", 5/64", 3/32", 1/8", 5/32", 3/16", 1/4", 5/16", 3/8", 1/2", 9/16", 5/8"	15	Imperial	81.90
TYQ013	698513	1/16", 5/64", 3/32", 1/8", 5/32", 3/16", 7/32", 1/4", 5/16", 3/8", 1/2", 9/16", 5/8"	13	Imperial	125.00
TYQ012	698310	1/8", 5/32", 3/16", 7/32", 1/4", 5/16", 3/8", 1/2", 9/16", 5/8"	10	Imperial	129.00
TYQ006	697115	0.7 mm, 0.9 mm, 1.3 mm, 1.5 mm, 2 mm, 2.5 mm, 3 mm, 4 mm, 5 mm, 6 mm, 8 mm, 10 mm, 12 mm, 14 mm, 17 mm	15	Metric	82.90
TYQ007	697310	3 mm, 4 mm, 5 mm, 6 mm, 7 mm, 8 mm, 10 mm, 12 mm, 14 mm, 17 mm	10	Metric	129.00
TYQ008	697513	1.5 mm, 2 mm, 2.5 mm, 3 mm, 4 mm, 5 mm, 5.5 mm, 6 mm, 8 mm, 10 mm, 12 mm, 14 mm, 17 mm	13	Metric	125.00

HEX KEY SET

- Made of premium steel for superior durability and corrosion resistance
- Deliver up to 33% more torque than ordinary hex keys
- Keys 1/8" & 3mm and larger have size permanently laser marked on the key



Model No.	Mfg. No.	Contains Sizes	No. of Keys	Drive Type	Price /Each
TYP993	68809	1.5 mm, 2 mm, 2.5 mm, 3 mm, 4 mm, 5 mm, 6 mm, 7 mm, 8 mm, 10 mm	9	Metric	11.90
YB131	69712	0.050", 1/16", 5/64", 3/32", 7/64", 1/8", 9/64", 5/32", 3/16", 7/32", 1/4", 5/16", 3/8"	13	Imperial	11.50
TYP990*	68713	0.050", 1/16", 5/64", 3/32", 7/64", 1/8", 9/64", 5/32", 3/16", 7/32", 1/4", 5/16", 3/8"	13	Imperial	16.50
YC455*	68709	1.5 mm, 2 mm, 2.5 mm, 3 mm, 4 mm, 5 mm, 6 mm, 7 mm, 8 mm, 10 mm	9	Metric	15.90

* Long Arm

BALL END HEX KEY SET

- Made of premium steel for superior durability and corrosion resistance
- Deliver up to 33% more torque than ordinary hex keys
- Keys 1/8" & 3mm and larger have size permanently laser marked on the key
- Ball end design offers greater access to fasteners from different angles in hard to reach applications



Model No.	Mfg. No.	Contains Sizes	No. of Keys	Drive Type	Price /Each
TYQ010	698113	0.050", 1/16", 5/64", 3/32", 7/64", 1/8", 9/64", 5/32", 3/16", 7/32", 1/4", 5/16", 3/8"	13	Imperial	21.90
TYQ005	697109	1.5 mm, 2 mm, 2.5 mm, 3 mm, 4 mm, 5 mm, 6 mm, 8 mm, 10 mm	9	Metric	18.50
TYP992*	68723	0.050", 1/16", 5/64", 3/32", 7/64", 1/8", 9/64", 5/32", 3/16", 7/32", 1/4", 5/16", 3/8", 1.5 mm, 2 mm, 2.5 mm, 3 mm, 4 mm, 5 mm, 6 mm, 8 mm, 10 mm	22	Metric & Imperial	32.50
TYP995*	68913	0.050", 1/16", 5/64", 3/32", 7/64", 1/8", 9/64", 5/32", 3/16", 7/32", 1/4", 5/16", 3/8"	13	Imperial	28.50
TYP994*	68909	1.5 mm, 2 mm, 2.5 mm, 3 mm, 4 mm, 5 mm, 6 mm, 8 mm, 10 mm	9	Metric	22.90
TYP991*	68722	0.050", 1/16", 5/64", 3/32", 7/64", 1/8", 9/64", 5/32", 3/16", 7/32", 1/4", 5/16", 3/8", 1.5 mm, 2 mm, 2.5 mm, 3 mm, 4 mm, 5 mm, 6 mm, 8 mm, 10 mm	22	Metric & Imperial	51.50

* Long Arm

T-HANDLE HEX KEY SET

- Made of premium steel for superior durability and corrosion resistance
- Deliver up to 33% more torque than ordinary hex keys
- Keys 1/8" & 3mm and larger have size permanently laser marked on the key
- Handle and blade are welded to create a single piece for maximum durability and strength
- Cushioned increases user comfort and reduces fatigue

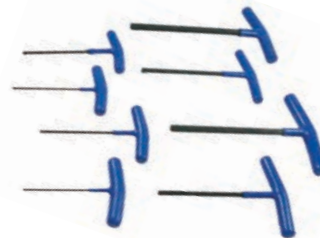

Model No.	Mfg. No.	Contains Sizes	No. of Keys	Drive Type	Price /Each
TYQ009	697608	2 mm, 2.5 mm, 3 mm, 4 mm, 5 mm, 6 mm, 8 mm, 10 mm	8	Metric	75.90
TYQ014	698610	3/32", 7/64", 1/8", 9/64", 5/32", 3/16", 7/32", 1/4", 5/16", 3/8"	10	Imperial	83.90

HEX KEY POUCH SETS

- Chrome vanadium steel for strength and durability
- Tips are chamfered for ease of entry and proper fit



Model No.	No. of Keys	Key Sizes	Price /Each
SAE - SHORT ARM			
TNB731	13	1/20", 1/16", 5/64", 3/32", 7/64", 1/8", 9/64", 5/32", 3/16", 7/32", 1/4", 5/16", 3/8"	9.60
METRIC - SHORT ARM			
TNB732	9	1.5 mm, 2.0 mm, 2.5 mm, 3.0 mm, 4.0 mm, 5.0 mm, 6.0 mm, 8.0 mm, 10.0 mm	7.75



TNB731

TNB732

HEX KEYS & PLIERS

FOLDING HEX KEY SETS

- Chrome vanadium steel for strength and durability
- Tips are chamfered for ease of entry and proper fit
- Set folds securely into convenient storage compartment

AURORA
TOOLS

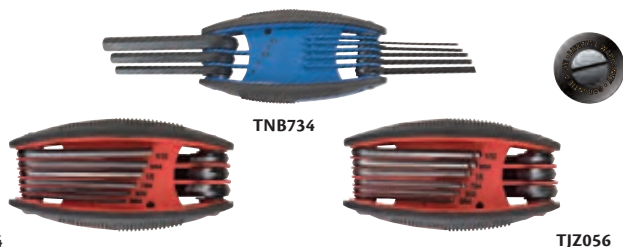

Model No.	No. of Keys	Key Sizes	Price /Each
SAE FOLD UP			
TNB733	9	5/64", 3/32", 7/64", 1/8", 9/64", 5/32", 3/16", 7/32", 1/4"	7.80
METRIC FOLD UP			
TNB734	8	1.5 mm, 2.0 mm, 2.5 mm, 3.0 mm, 4.0 mm, 5.0 mm, 6.0 mm, 8.0 mm	7.85
SAE - BALL END FOLD UP			
TNB735	9	5/64", 3/32", 7/64", 1/8", 9/64", 5/32", 3/16", 7/32", 1/4"	9.25

ALLEN KEY

- PVC grip provides comfort and allows increased torque
- S2 alloy steel hardened to HRC58-62 for maximum strength and endurance
- Flat nose design for highest torque on the toughest fasteners
- Colour coded to indicate S.A.E., Metric, or Torx® sizes
- Manganese phosphate finish resists corrosion
- Style: T Handle



JET

Model No.	Mfg. No.	Tip Size	Price /Each
AUW159	774410	1/8"	13.30
AUW160	774412	5/32"	14.50
AUW161	774460	4 mm	14.50
AUW162	774462	5 mm	16.00
AUW122	774466	8 mm	21.60

T-HANDLE HEX KEY SET

- PVC grip provides comfort and allows increased torque
- S2 alloy steel hardened to HRC58-62 for maximum strength and endurance
- Flat nose design for highest torque on the toughest fasteners
- Colour coded to indicate S.A.E., Metric, or Torx® sizes
- Manganese phosphate finish resists corrosion



JET

Model No.	Mfg. No.	No. of Keys	Drive Type	Includes	Price /Each
AUW163	775105	8	Metric	2 mm, 2.5 mm, 3 mm, 4 mm, 5 mm, 6 mm, 8 mm, 10 mm	72.40
AUW164	775109	10	Imperial	3/32", 7/64", 1/8", 9/64", 5/32", 3/16", 7/32", 1/4", 5/16", 3/8"	88.90

SLIP-JOINT PLIERS

- Nickel-chrome plated finish
- Shear-type wire cutters
- Adjustable two-position jaws
- Plastic-dipped handles



KLEIN TOOLS
For Professionals... Since 1857

Model No.	Mfg. No.	Overall Length"	Price /Each
TJ912	D511-6	6-9/16	29.10
TJ913	D511-8	8-1/16	36.70
TJ914	D511-10	9-7/8	45.50

HIGH LEVERAGE SIDE CUTTERS WITH CRIMPING DIE

- Smooth, streamlined nose with knurled jaws
- High-leverage design for maximum power



KLEIN TOOLS
For Professionals... Since 1857

Model No.	Mfg. No.	Overall Length"	Price /Each
TJ889	D213-9NE-CR	9-3/8	75.80
TJ890*	D2000-9NE-CR	9-3/8	94.70

* Has extra heavy-duty side cutters.

GROOVE JOINT PLIERS

- Tongue and groove design
- Adjusts to fit within its maximum capacity
- Anti-slip jaws
- Plastic-dipped handles



KLEIN TOOLS
For Professionals... Since 1857

Model No.	Mfg. No.	Overall Length"	Maximum Capacity"	Price /Each
TJ915	D502-6	7/8	7/8	39.20
TJ916	D502-10	10	1-3/4	45.50
TJ917	D502-12	12-1/4	2-1/8	55.60
TJ918	D502-16	16-3/4	4-1/4	103.00

HIGH LEVERAGE SIDE CUTTERS WITH BOLT HOLDER

- Smooth, streamlined nose with knurled jaws
- High-leverage design for maximum power
- Designed to hold 5/8"-11 bolts without damaging them
- Plastic-dipped handles



KLEIN TOOLS
For Professionals... Since 1857

Model No.	Mfg. No.	Overall Length"	Price /Each
TJ891	D213-9NETH	9-3/8	69.50
TJ892*	HD213-9NETH	9-1/2	79.60

* Has extra heavy-duty side cutters.

SIDE CUTTING PLIERS

- Hardened cutting edges for longer life
- Alignment of the cutting edges allows for quick and clean cut
- Drop forged steel resulting in superior strength flexibility and longer tool life
- PVC dipped handles
- **Limited lifetime warranty**
- Meets ANSI standards



Model No.	Mfg. No.	Overall Length"	Jaw Length"	Price /Each
TYR691	B245B	5-1/2	3/4	37.50
TYR692	B246B	7-1/4	3/4	45.90
TYR693	B247B	8	3/4	48.50
TYR694	B249	10	1	70.90

NEEDLE NOSE PLIERS

- Precisely machined serrated teeth provide a safe and secure hold
- Alignment of the cutting edges allows for quick and clean cut
- Curved nose design provides improved reach and access in confined space or obstructed applications
- Drop forged steel resulting in superior strength flexibility and longer tool life
- **Limited lifetime warranty**
- Meets ANSI standards



Model No.	Mfg. No.	Overall Length"	Jaw Length"	Price /Each
TYR760	B238B	6-1/4	2	36.50
TYR761	B239B	8	2-3/4	45.90

NEEDLE NOSE STRAIGHT CUTTER PLIERS

- Precisely machined serrated teeth provide a safe and secure hold
- Alignment of the cutting edges allows for quick and clean cut
- Needle nose design allows for improved reach and access in confined space applications
- Drop forged steel resulting in superior strength flexibility and longer tool life
- **Limited lifetime warranty**
- Meets ANSI standards



Model No.	Mfg. No.	Overall Length"	Jaw Length"	Price /Each
TYR758	B230B	5-1/2	1-1/2	37.50
TYR759	B231B	6-1/2	2	38.50

LONG REACH HEAVY-DUTY PLIERS

- Long length design makes it ideal for use in hard to reach applications
- Cuts hard wires and cotter pins
- **Limited lifetime warranty**
- Meets ANSI standards



TYR688



TYR755



TYR756



Model No.	Mfg. No.	Description	Overall Length"	Price /Each
TYR688	82001	Diagonal	11-1/4	105.00
TYR755	82002	Straight Needle Nose	11-3/4	105.00
TYR756	82003	Bent Needle Nose	11-1/2	105.00

HIGH LEVERAGE SIDE CUTTERS

- Smooth, streamlined nose with knurled jaws
- High-leverage design for maximum power
- Plastic-dipped handles (TJ887 has thicker heavy-duty grips)



Model No.	Mfg. No.	Overall Length"	Price /Each
TJ885	D213-8NE	8-11/16	63.20
TJ886	D213-9NE	9-1/4	61.90
TJ887	HD213-9NE	9-1/2	70.80
TJ888*	D2000-9NE	9-3/8	77.70

* Has extra heavy-duty side cutters.

RATCHETING CABLE CUTTERS

- Cuts cable straight with minimum effort
- Cuts up to: 750 mcm aluminum (not ACSR), 600 mcm copper
- Quick release mechanism and hold open spring
- Plastic finger formed grips



Model No.	Mfg. No.	Overall Length"	Price /Each
TJ953	63060	10	428.00

HIGH LEVERAGE CABLE CUTTERS

- Cuts cables with remarkable ease
- Cuts up to: 4/0 aluminum (not ACSR), 2/0 soft copper
- Compact design fits easily in most tool pouches
- Plastic-dipped handles



Model No.	Mfg. No.	Overall Length"	Price /Each
VU139	63050	9-9/16	58.10

HIGH-LEVERAGE CABLE CUTTERS

- High-leverage jaws with shear-cut blades
- Cuts up to: 4/0 aluminum cable (not ACSR), 2/0 soft copper cable
- Plastic covered, non-slip grips
- Compact cutter fits in most tool pouches
- NOT an insulated tool
- Overall Length: 9 1/2"

Model No. TBG092
Mfg. No. 0890CSJ
Price/Each \$42.90

CRESCENT
H.K. PORTER



PLIERS



SIDE CUTTERS FOR REBAR WORK

- Specially designed knurled jaws
- Cutter designed to cut rebar tie wire
- Hook bend in one handle for no-slip grip
- Coil spring holds jaws open
- Plastic-dipped handles



Model No.	Mfg. No.	Overall Length"	Price /Each
TJ893	D201-7CST	9-1/4	74.50
TJ894*	D2000-7CST	9-1/4	94.70

* Has extra heavy-duty side cutters.



HIGH LEVERAGE SIDE CUTTERS FOR REBAR WORK

- High-leverage design for maximum power
- Cutter designed to cut rebar tie wire
- Hook bend in one handle for no-slip grip
- Coil spring holds jaws open
- Plastic-dipped handles



Model No.	Mfg. No.	Overall Length"	Price /Each
TJ895	D213-9ST	9-3/8	75.80
TJ896*	D2000-9ST	9-3/8	97.90

* Has extra heavy-duty side cutters.

HIGH-LEVERAGE DIAGONAL CUTTERS

- High-leverage design for maximum power
- Standard bevel cut design
- Plastic-dipped, hand-form style handles



Model No.	Mfg. No.	Overall Length"	Price /Each
TJ897	D228-8	8-1/16	50.50
TJ898*	D2000-28	8-1/16	56.90

* Has extra heavy-duty cutters.



ANGLED HEAD DIAGONAL CUTTERS

- High-leverage design for maximum power
- Standard bevelcut design
- Angled head for easier work in confined areas
- Plastic-dipped, hand-form style handles



Model No.	Mfg. No.	Overall Length"	Price /Each
TJ899	D248-8	8-1/16	50.60
TJ900*	D2000-48	8-1/16	63.20

* Has extra heavy-duty cutters.

TAPERED NOSE DIAGONAL CUTTERS

- Tapered nose for working in confined areas
- Standard bevel cut design
- Plastic-dipped, hand-form style handles



Model No.	Mfg. No.	Overall Length"	Price /Each
TJ903	D202-6	6-1/8	56.90
TJ904*	D202-6C	6-1/8	58.10

* Has coil spring to hold jaws open.



MIDGET TAPERED NOSE DIAGONAL CUTTERS

- Sharp nose for reaching into confined areas
- Semi-flush cut design
- Plastic-dipped handles



Model No.	Mfg. No.	Overall Length"	Price /Each
TJ905	D245-5	5-1/16	58.10

MIDGET POINTED NOSE DIAGONAL CUTTERS

- Sharp nose for reaching into confined areas
- Semi-flush cut design
- Coil spring holds jaws open
- Plastic-dipped handles



Model No.	Mfg. No.	Overall Length"	Price /Each
TJ907	D209-4C	4-1/4	58.10
TJ908	D209-5C	5-1/16	58.10



MIDGET STANDARD NOSE DIAGONAL CUTTERS

- General purpose cutter
- Semi-flush cut design
- Plastic-dipped handles



Model No.	Mfg. No.	Overall Length"	Price /Each
TJ909	D257-4	4-1/4	58.10
TJ910*	D257-4C	4-1/4	63.20

* Has coil spring to hold jaws open.

MIDGET TAPERED NOSE DIAGONAL CUTTERS

- Small head for precise cuts in hard-to-reach areas
- Flush cut design for a squared off finish
- Has coil spring to hold jaw open
- Plastic-dipped handles



Model No.	Mfg. No.	Overall Length"	Price /Each
TJ911	D295-4C	4-1/4	70.80

STANDARD LONG NOSE PLIERS

- Knurled jaws for solid grip
- Durable design for long life
- Plastic-dipped handles



Model No.	Mfg. No.	Overall Length"	Price /Each
TJ925	D301-6	6-5/8	43.00
TJ928*	D301-6C	6-5/8	45.50



* Has coil spring to hold jaws open.

LONG NOSE WITH SIDE CUTTER

- Knurled jaws for solid grip
- Side cutter
- Plastic-dipped handles



Model No.	Mfg. No.	Overall Length"	Price /Each
TJ931	D203-6	6-5/8	45.50
TJ932	D203-7	7-3/16	45.50
TJ933	D203-8	8-7/16	56.90
TJ935*	D203-6C	6-5/8	51.80
TJ936*	D203-7C	7-3/16	50.60



* Has coil spring to hold jaws open.

LONG NEEDLE NOSE PLIERS

- Knurled jaws for solid grip
- Ideal for assembly work in tight areas
- Coil spring to hold jaws open
- Plastic-dipped handles



Model No.	Mfg. No.	Overall Length"	Price /Each
TJ938	D318-51/2C	5-5/8	53.10

SLIM LONG NOSE PLIERS

- Knurled jaws for solid grip
- Needle tip only 1/32" for precise work
- Coil spring to hold jaws open
- Plastic-dipped handles



Model No.	Mfg. No.	Overall Length"	Price /Each
TB1712	D307-51/2C	5-5/8	48.00

MIDGET SLIM NOSE PLIERS

- Knurled jaws for solid grip
- Designed for extremely precise work
- Coil spring to hold jaws open
- Plastic-dipped handles



Model No.	Mfg. No.	Overall Length"	Price /Each
TJ940	D321-41/2C	4-3/16	45.50

MIDGET CURVED NEEDLE NOSE PLIERS

- Polished jaws to prevent wire nicking
- Angled tip for intricate work
- Coil spring to hold jaws open
- Plastic-dipped handles



Model No.	Mfg. No.	Overall Length"	Price /Each
TJ941	D320-41/2C	4-3/4	58.10

WIRE STRIPPERS/CUTTERS

- Hardened steel construction for long life
- Narrow nose design fits into hard to reach areas
- Black oxide finish
- Plastic-dipped handle



Model No.	Mfg. No.	Strips AWG Gauges	Overall Length"	Price /Each
TJ946	11045	10, 12, 14, 16, 18 solid wire	6-1/4	26.50
TJ947	11046	16, 18, 20, 22, 24, 26 stranded	6-1/4	26.80
TJ948	11047	22, 24, 26, 28 30 solid wire	6-1/4	29.70



WIRE STRIPPERS/CUTTERS

- Scissor style with 1/2" cutter
- Nose designed to bend, shape or pull wire
- Holes for looping wire ends
- Coil spring to hold jaws open
- Plastic-dipped handles

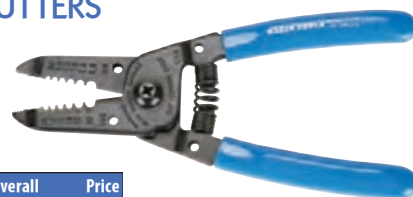

Model No.	Mfg. No.	Strips AWG Gauges	Overall Length"	Price /Each
TJ949	1011	10, 12, 14, 16, 18, 20	6-1/8	25.30



COMPACT WIRE STRIPPERS/CUTTERS

- Lightweight, compact design
- Nut along side locks in required stripping size
- Hole for looping wire ends
- Plastic-dipped handles



Model No.	Mfg. No.	Strips AWG Gauges	Overall Length"	Price /Each
TJ950	1004	12 - 26	5	17.70
TJ951*	1003	12 - 26	5	20.20



* With spring to hold jaws open.

ALL-PURPOSE LONG NOSE TOOLS

- Cuts bolts and wire, strips and crimps
- Nose designed to bend, shape or pull wire
- Long nose for reaching into tight areas
- Plastic-dipped handles



Model No.	Mfg. No.	Strips AWG Gauges	Overall Length"	Price /Each
TJ952	1010	10 - 22	8-1/4	44.20



PLIERS

LINESMAN CUTTING PLIERS

- Precision milled jaw grip and hold wire without slipping
- Black nickel finish resists rust
- Meets ANSI standards



AURORA
TOOLS

Model No.	Overall Length"	Price /Each
UAV662	7	12.85
UAV663	8	13.75

SLIP JOINT PLIERS

- Sure gripping precision milled jaws
- Light and rugged drop-forged alloy steel
- Flush pivot design for use in tight spaces
- Meets ANSI standards



AURORA
TOOLS

Model No.	Overall Length"	Price /Each
UAV655	6	9.15

DIAGONAL CUTTING PLIERS

- Precision tested jaws provide uniform cut
- Slim profile reaches into cramped quarters
- Black nickel finish resists rust
- Induction heat-treated cutting edge
- Smooth non-sticking lever mechanism
- Meets ANSI standards



AURORA
TOOLS

Model No.	Overall Length"	Price /Each
UAV658	6	9.55
UAV659	7-1/2	12.95

CUTTING PLIERS

- Strong sure gripping jaws manipulate wire and other awkward objects
- Slim tapered head extends reach and maintains visibility in small areas
- Black nickel finish resists rust
- Meets ANSI standards



AURORA
TOOLS

Model No.	Overall Length"	Price /Each
UAV660	6	9.80
UAV661	8	12.15

GROOVE JOINT PLIERS

- Sure gripping precision milled jaws
- Grooves undercut and milled to prevent slipping when tightening
- Light and rugged drop-forged alloy steel
- Flush pivot design for use in tight spaces
- Meets ANSI standards



AURORA
TOOLS

Model No.	Overall Length"	Price /Each
UAV656	8	12.70
UAV657	10	15.85

BASIC PLIER SET

- Precision milled jaws
- Black nickel finish resists rust
- Meets ANSI standards
- No. of Pieces: 3
- Includes:
 - 6" L Slip joint,
 - 6" L Diagonal cutting,
 - 6" L Long nose cut

Model No. UAV790
Price/Each \$25.65



AURORA
TOOLS

ALL-PURPOSE PLIER SET

- Precision milled jaw grips and holds wire without slipping
- Black nickel finish resists rust
- Meets ANSI standards
- No. of Pieces: 9
- Includes:
 - 6" L Slip joint,
 - 8" & 10" L Groove joint,
 - 6" & 7.5" L Diagonal cutting,
 - 6" & 8" L Long nose cut,
 - 7" & 8" L Linesman cutting

Model No. UAV791
Price/Each \$103.00



AURORA
TOOLS

TONGUE & GROOVE SLIP JOINT PLIERS

- Sharp, angled teeth ensure a safe and secure grip of the work piece
- Multiple position joint adjusts to match a variety of applications
- Forged and heat-treated for maximum service life
- **Limited lifetime warranty**
- Meets ANSI standards



GRAY TOOLS

Model No.	Mfg. No.	Overall Length"	Jaw Length"	Price /Each
TYR698	B45-20	20	3	209.00

LOCKING PLIERS

- Tempered chrome vanadium steel jaws
- Hardened tension bar with toggle mechanism provides secure locking action
- Smooth screw adjustment for easy and rapid setting
- Meets ANSI standards



CURVED JAWS WITH WIRE CUTTER

Model No.	Grip	Length"	Price/Each
UAV664	Steel	5	10.95
UAV665	Composite	7	13.95
UAV666	Composite	10	16.50



LONG NOSE WITH WIRE CUTTER

Model No.	Grip	Length"	Price/Each
UAV667	Steel	6.5	11.65



C-CLAMPS WITH SWIVEL PADS

Model No.	Grip	Length"	Price/Each
TJZ096	Steel	6	14.20



LOCKING WELDING CLAMPS

Model No.	Grip	Length"	Price/Each
TJZ098	Steel	9	21.50



LOCKING SHEET METAL TOOLS

Model No.	Grip	Length"	Price/Each
TJZ099	Steel	8	17.80



WELDER CLAMP SET

- Set Includes:
 - 6" L C-clamps w/swivel pads (TJZ096)
 - 11" C-Clamp with swivel pad (UAV668)
 - 9" locking welding clamp (TJZ098)
 - 8" locking sheet metal clamp (TJZ099)

• Grip: Steel
 Model No. TLV133
 Price/Each \$77.55



WISE-GRIP®



CURVED JAWS WITH WIRE CUTTER

Model No.	Overall Length"	Price/Each
TM909	4	18.50
TM910	5	20.50
TM917	7	20.90
TM873	10	21.50



STRAIGHT JAWS

Model No.	Overall Length"	Price/Each
TM916	7	20.90
TM872	10	21.50



LONG NOSE WITH WIRE CUTTER

Model No.	Overall Length"	Price/Each
TM908	4	20.90
TM912	6	20.70
TM952	9	26.50



LOCKING CHAIN CLAMPS

Model No.	Overall Length"	Price/Each
TM985	9	46.90
TM984*	18	23.90

* Extension chain.



C-CLAMPS WITH REGULAR TIPS

Model No.	Overall Length"	Price/Each
TM913	6	19.50
TM971	11	32.90
TM980	18	47.90
TM996	24	59.50



C-CLAMPS WITH SWIVEL PADS

Model No.	Overall Length"	Price/Each
TN052	4	19.50
TM914	6	21.90
TM972	11	35.50
TM981	18	49.50
TM997	24	61.50



LOCKING WELDING CLAMPS

Model No.	Overall Length"	Price/Each
TN198	9	36.90



LOCKING SHEET METAL TOOLS

Model No.	Overall Length"	Price/Each
TN197	8	30.90



LARGE JAW LOCKING PLIERS

Model No.	Overall Length"	Price/Each
TM875	12	32.50



LOCKING WRENCHES WITH WIRE CUTTER

Model No.	Overall Length"	Price/Each
TD351	10	27.90
TD352	7	21.90
TD353	4	18.90



PLIERS



6-PIECE LOCKING PLIERS SETS

KIT INCLUDES:

- Curved jaw w/wire cutter, 5" L (UAV664)
- Curved jaw w/wire cutter, 7" L (UAV665)
- Curved jaw w/wire cutter, 10" L (UAV666)
- Long nose w/wire cutter, 6.5" L (UAV667)
- C-clamps w/swivel pads, 6" L (TJZ096)
- C-clamps, 11" L (UAV668)

Model No. TLZ792
Price/Each \$105.00



UAV664



UAV665



UAV666



UAV667



TJZ096



UAV668

CONVERTIBLE RETAINING RING PLIERS



Model No.	Mfg. No.	Overall Length"	Tip Angle	Price /Each
TYR783	B116C	6	18°	39.50
TYR784	B117C	6	18°	41.90
TYR785	B118C	7-1/4	18°	45.90
TYR792	B136C	5-3/4	90°	41.90
TYR795	B137C	6	90°	44.50
TYR797	B138C	7	90°	47.90

SNAP RING PLIERS

- Converts from internal to external or vice versa in seconds
- Quick adjustment knob allows user to switch from internal to external without removing or tightening screws
- Replaceable tips are precision formed and hardened for accurate fit and long wear
- Large cushioned grips
- Pliers are spring-loaded to reduce fatigue



Model No.	Mfg. No.	Overall Length"	Tip Angle	Price /Each
NJH072	83406	6	0°/90°	50.50
TYR769	83408	8	0°/90°	58.50
TYR770	83410	10	15°/90°	115.00
TYR825	83903	Set of 3, includes NJH072, TYR769 and TYR770		205.00

INDUSTRIAL MULTI-TOOLS

- Stainless steel components
- Anodized aluminum body with ABS inlays provides premium comfort
- Heavy-duty nylon pouch
- Self locking components for safe use
- Gun metal finish

Components: Flat-nose pliers, wire cutter, fine edge knife, Phillips screwdriver, bottle opener, small and medium flat screwdriver, metal/wood file, double tooth saw, serrated knife, can opener

Specifications:

Overall Length: 6.25"
Closed Length: 4"
Weight: 9.3 oz.

Model No. TLZ463
Price/Each \$19.95



LONG NOSE LOCKING PLIER

- Unique 70 degree angled design keeps wrist straight, reducing strain and fatigue
- Drop forged jaws ensure long-term durability
- Piano wire spring ensures superior tool life and reliable opening and closing of tool
- Improved design reduces the gap between lever and handle protecting the spring
- Style: Omnium Grip



Model No.	Mfg. No.	Overall Length"	Jaw Opening"	Price /Each
TYR753	727-08	6-1/2	1-9/16	90.90

HEAVY-DUTY RATCHETING SNAP RING PLIERS SET

- Heavy-duty pliers for use on large, high tension retaining rings
- Spring loaded ratcheting mechanism reduces operator fatigue and enhances safety
- Rings can be compressed or expanded in stages and locked in place
- Heat treated high carbon steel pliers with Chrome Molybdenum tips
- External Capacity: 1-1/2" - 3-3/4"
- Internal Capacity: 2-7/16" - 4"
- Includes: (1) External Plier, (1) Internal Plier, (16) Chrome Molybdenum Tips - 0°, 15°, 45°, 90° x .108"/.120", (6) Spare Screws, (1) Carrying Case
- Length: 10-1/2"

Model No. AUW106
Mfg. No. 730355
Price/Each \$208.00



HEAVY-DUTY SLIP JOINT PLIERS

- Heavy duty drop forged Cr-Mo steel pliers designed for professional automotive applications
- Square nose design with deep cross-hatched teeth for gripping, pulling, and twisting heavy gauge wire
- Shear type cutter works on small diameter screws and bolts
- Machined mating surfaces allow precise riveting with minimal side play
- Jaws and cutters induction hardened to HRC58
- Slip joint increases jaw opening and allows use on a wide range of fasteners



Model No.	Mfg. No.	Overall Length"	Price /Each
AUW108	730407	10	55.30

AUTOMATIC WIRE STRIPPER

- One quick light squeeze strips wire up to a full 1" without nicking, cutting or fraying
- Automatic wire gripper holds wire centered in stripping hole
- Lever action offers stripping and insulation removal in one step
- Adjustable wire stop to ensure uniform, precise strip length
- Strips AWG Gauges: 8 - 22



Model No.	Mfg. No.	Overall Length"	Price /Each
AUW109	730731	7	65.40

NEEDLE NOSE PLIERS

- Extra compact pliers for fine work and access to restricted areas
- Spring loaded handles open pliers automatically, reducing hand fatigue
- Chrome vanadium steel for professional use
- Nickel plating resists corrosion
- Dual moulded TPR handles provide secure non-slip grip for user safety



Model No.	Mfg. No.	Overall Length"	Price /Each
AUW153	730606	5	14.90

SELF-ADJUSTING WIRE STRIPPER

- Self-adjusting stripper automatically applies correct pressure to strip insulation without nicking wire
- Fine adjustment screw allows customized pressure on various plastic insulation
- Can be used to strip several wires simultaneously
- Includes: Wire Cutter



Model No.	Mfg. No.	Overall Length"	Price /Each
AUW154	730736	6-1/2	33.90

MOVING YOU FORWARD

KLETON

PLIERS

MECHANIC'S PLIERS SET

- Made of high quality Chrome Vanadium steel (except slip joint)
- Cutting edges induction hardened to HRC58-63
- Double-dipped cushion grip handles offer superior comfort, sure gripping action and long life
- No. of Pieces: 5
- Includes:
 - 8" Angle Head Cutter,
 - 8" Long Nose,
 - 8" Linemans,
 - 8" Slip Joint,
 - 8" Groove Joint
- Standard(s) Met: ANSI

Model No. AUW104
Mfg. No. 730341
Price/Each \$126.00



HIGH LEVERAGE PLIERS SET

- Patented double leverage compound joint design reduces hand effort for heavy duty cutting applications
- Requires 60% less effort than regular pliers
- Cutting edges induction hardened to HRC58 for cutting the hardest materials
- Hidden spring opens pliers automatically, reducing fatigue
- Handle lock keeps pliers closed for safe storage in tool box
- Asymmetric handles designed for maximum comfort under high pressure
- Dual moulded materials provide secure non-slip grip for user safety
- No. of Pieces: 3
- Includes: 7-1/2", 8", 9"
- Piano Wire Capacity: 2.5 mm
- Hard Wire Capacity: 3 mm

Model No. AUW101
Mfg. No. 730303
Price/Each \$122.00



STARTER PLIERS SET

- Made of high quality Chrome Vanadium steel (except slip joint)
- Cutting edges induction hardened to HRC58-62
- Double-dipped cushion grip handles offer superior comfort, sure gripping action and long life
- No. of Pieces: 4
- Includes:
 - 6-1/2" Diagonal Cutter,
 - 6-1/2" Long Nose,
 - 7" Linemans,
 - 8" Slip Joint
- Standard(s) Met: ANSI

Model No. AUW103
Mfg. No. 730311
Price/Each \$60.10



PUSH-BUTTON RATCHETING PLIERS SET

- Push button ratcheting pliers lock in setting for repetitive work
- Maintains size when handles opened and will not slip out of adjustment like standard groove joint pliers
- Fine indexing adapts to various workpieces, pipes, fasteners, and bar stock
- Ultra-thin jaws direct force to smaller area for reduced effort and reliable non-slip grip
- Specially hardened chrome vanadium steel teeth guarantee maximum grip with minimal hand force
- Self-locking on pipes and nuts
- Double layer handles for improved grip and comfort
- Anti-pinch design for safe use
- No. of Pieces: 3
- Hex Capacities: 1-3/8", 1-3/4", 2-3/16"
- Round Capacities: 1-1/2", 2", 2-3/4"
- Jaw Width: 3/8"
- Number of Indexes: 19, 24, 32
- Includes: 7-1/4", 9-1/4", 12"

Model No. AUW107
Mfg. No. 730381
Price/Each \$191.00



SUPER HEAVY-DUTY SNAP RING PLIERS SET

- Specially hardened SUJ2 bearing steel tips are angled to safely retain circlips while compressing or expanding
- Up to 10 times the life of turned tips
- Patented hidden spring mechanism returns pliers to neutral position, reducing hand fatigue
- Screw joint is adjustable for zero-backlash
- Textured handles provide safe non-slip grip
- No. of Pieces: 4
- Includes:
 - 7" Internal Straight,
 - 7" Internal Bent,
 - 7" External Straight,
 - 7" External Bent

Model No. AUW105
Mfg. No. 730354
Price/Each \$176.00



SUPER HEAVY-DUTY INDUSTRIAL PLIERS SET

- Chrome Vanadium steel construction for heavy-duty industrial applications (slip joint pliers made of high carbon steel)
- Computer-controlled machining of all mating surfaces guarantees smooth operation and maximum stability under load
- Induction heat treated cutting edges hardened to HRC56 - 65 for long life and excellent performance on a variety of materials
- Tapered rivets eliminate handle swing and provide consistent blade alignment for superior cutting performance
- Computer-controlled grinding and sanding processes for a professional look and feel
- Dual injection moulded handles feature a tread-like gripping surface to prevent slipping and enhance user safety
- Phosphate finished with electrophoretic clear coat for resistance to corrosion
- No. of Pieces: 5
- Includes:
 - 8" Slip Joint Pliers,
 - 8" Linemans Pliers,
 - 8" Long Nose Pliers,
 - 7-1/2" Diagonal Cutters,
 - 10" Groove Joint Pliers

Model No. AUW102
Mfg. No. 730306
Price/Each \$164.00



RETAINING RING PLIERS WITH STRAIGHT TIPS

- Features a secure ratchet locking mechanism and large cushioned grips
- Range Capacity: 3-1/2" - 6-1/2"



Model No.	Mfg. No.	Overall Length"	Tip Angle	Price /Each
TCU064	82515A	16	0	169.00

CABLE STRIPPING KNIVES 1000 V W/HOOK BLADE



Model No.	Mfg. No.	OAL mm	Price/Each
THZ506	120044	35	49.61

CABLE STRIPPING KNIVES 1000 V W/INSULATED BLADE BACK



Model No.	Mfg. No.	OAL mm	Price/Each
THZ505	120043	50	63.06

INSULATED, SPECIAL PROFILATED PHILLIPS- TIP SCREWDRIVERS

- High quality tempered steel shank and heat-treated tip
- Cushion-grip handle for user comfort



Model No.	Mfg. No.	Tip No.	Shank Length"	Price/Each
TV561	6334-INS	1	4	36.60
TV562	603-4-INS	2	4	36.70
TLV663	6337-INS	3	6	43.70

INSULATED, SLOT CABINET TIP SCREWDRIVERS

- High quality tempered steel shank and heat-treated tip
- Cushion-grip handle for user comfort



Model No.	Mfg. No.	Tip Width"	Shank Length"	Price/Each
TV558	601-4-INS	3/16	4	35.50
TNB726	601-7-INS	3/16	7	37.90

INSULATED, SQUARE RECESS TIP SCREWDRIVERS

- High quality tempered steel shank and heat-treated tip
- Cushion-grip handle for user comfort



Model No.	Mfg. No.	Tip No.	Shank Length"	Price/Each
TLV674	661-7-INS	1	7	37.90
TLV675	662-7-INS	2	7	38.00

INSULATED HEAVY-DUTY, SLOT KEYSTONE TIP SCREWDRIVERS

- High quality tempered steel shank and heat-treated tip
- Cushion-grip handle for user comfort



Model No.	Mfg. No.	Tip Width"	Shank Length"	Price/Each
TV555	602-4-INS	1/4	4	41.70
TLV551	602-8-INS	3/8	8	54.50

PHILLIPS SCREWDRIVERS, 1000 V



Model No.	Mfg. No.	Tip No.	Shank Length mm	Price/Each
THZ394	117730	0	60	17.61
THZ395	117731	1	80	21.74
THZ396	117732	2	1000	28.65
THZ397	117733	3	150	38.20

ELECTRICIAN'S SCREWDRIVERS, 1000 V



Model No.	Mfg. No.	OAL mm	Tip mm	Shank Length	Price /Each
THZ386	117701	155	2.5 x 0.4	75	17.61
THZ387	117702	180	3.0 x 0.5	100	17.61
THZ388	117703	185	3.5 x 0.6	100	19.03
THZ389	117704	185	4.0 x 0.8	100	20.21
THZ390	117705	225	5.5 x 1.0	125	26.28
THZ391	117706	250	6.5 x 1.2	150	31.77
THZ392	117708	285	8.0 x 1.2	175	31.77
THZ393	117710	315	10.0 x 1.6	200	51.68

INSULATED HOLLOW SHAFT NUT DRIVERS

- Full length insulation on shaft
- Hollow shaft to fit over long screws
- Cushion-grip handle for user comfort



Model No.	Mfg. No.	Hex Size"	Shank Length"	Price/Each
TLV665	646-3/16-INS	3/16	6	35.40
TLV666	646-1/4-INS	1/4	6	36.80
TLV667	646-5/16-INS	5/16	6	36.70
TLV668	646-11/32-INS	11/32	6	36.60
TLV669	646-3/8-INS	3/8	6	36.70
TLV670	646-7/16-INS	7/16	6	40.50
TLV671	646-1/2-INS	1/2	6	41.80
TLV672	646-9/16-INS	9/16	6	48.00
TLV673	646-5/8-INS	5/8	6	53.00

NUT DRIVER

- Cushioned non-slip handle
- Features an orange top insulation layer, and a second yellow layer that also serves as a visual safety indicator
- Provides user protection for up to 1000 V
- Individually insulated and tested to ASTM F1505 standards
- Limited Lifetime Warranty



Model No.	Mfg. No.	Hex Size"	Length"	Price/Each
TYR893	CH06-I	3/16	6-1/2	28.90
TYR896	CH08-I	1/4	6-1/2	27.90
TYR899	CH10-I	5/16	7	29.90
TYR901	CH11-I	11/32	7	34.50
TYR903	CH12-I	3/8	7	34.50
TYR904	CH14-I	7/16	8	29.50
TYR905	CH16-I	1/2	8	29.90

Model No.	Mfg. No.	Hex Size mm	Length"	Price/Each
TYR892	CH05M-I	5	6-1/2	27.90
TYR894	CH06M-I	6	6-1/2	26.50
TYR895	CH07M-I	7	7	27.50
TYR897	CH08M-I	8	7	28.50
TYR898	CH09M-I	9	7	28.90
TYR900	CH10M-I	10	8	29.50
TYR902	CH11M-I	11	8	29.50

CLAMPS

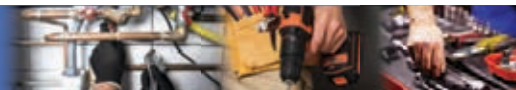

BAR CLAMPS FOR WELDING & FABRICATING

SHOP FLOOR CLAMPS

- Swivel pressure pad
- Rail and fixed top jaw are heat treated and tempered
- High quality construction insures long life

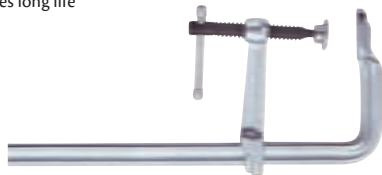

Model No.	Mfg. No.	Pad	Clamping Capacity"	Throat Depth"	Clamping Force (lbs.)	Price /Each
TKZ890	6605-8	Standard-duty	8	4	660	78.00
TKZ891	6605-12	Standard-duty	12	4	660	83.40
TKZ892	6605-18	Standard-duty	18	4	660	92.00
TN210	SQ-4	Standard-duty	6	4 3/4	1330	72.90
TN211	SQ-8	Heavy-duty	8	5 1/2	2660	134.00
TD320	SQ-12	Heavy-duty	12	5 1/2	2660	154.00
TKZ893	SQ-16	Heavy-duty	16	5 1/2	2660	175.00
TD321	SQ-20	Heavy-duty	20	5 1/2	2660	193.00
TKZ894	SQ-24	Heavy-duty	24	5 1/2	2660	218.00

PROFESSIONAL CLAMPS

- Bessey® Morpad™ allows for greater angle of pivot
- Rail and fixed top jaw are heat treated and tempered
- High quality construction insures long life

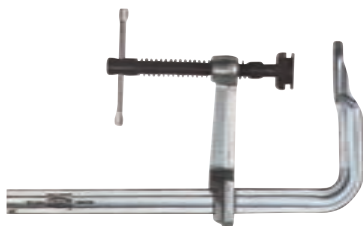

Model No.	Mfg. No.	Clamping Capacity"	Throat Depth"	Clamping Force (lbs.)	Price /Each
HEAVY-DUTY					
TN047	48005-12	12	7	4880	380.00
THZ886	48005-18	18	7	4880	408.00
TKZ901	48005-24	24	7	4880	440.00
THZ887	48005-36	36	7	4880	525.00
TKZ902	48005-48	48	7	4880	607.00
TKZ903	48005-60	60	7	4880	692.00
EXTRA HEAVY-DUTY					
TN177	72005-12	12	8	7770	954.00
THZ888	72005-18	18	8	7770	1016.00
THZ889	72005-36	36	8	7770	1170.00

REGULAR-DUTY ALL-STEEL BAR CLAMPS WITH ERGONOMIC BESSEY® GRIP



Model No.	Mfg. No.	Clamping Capacity"	Throat Depth"	Clamping Force (lbs.)	Price /Each
TLY342	24005-8	8	5 1/2	2800	183.00
TLY343	24005-12	12	5 1/2	2800	210.00
TLY344	24005-16	16	5 1/2	2800	239.00
TLY345	24005-20	20	5 1/2	2800	263.00
TLY346	24005-24	24	5 1/2	2800	298.00
TLY347	24005-36	36	5 1/2	2800	364.00
TLY348	24005-48	48	5 1/2	2800	436.00
TLY349	24005-60	60	5 1/2	2800	501.00

STEP-OVER STEEL CLAMPS

- Rail, fixed jaws and pressure plate heat-formed in one piece from cold drawn profiled and precision steel
- Heat treated, high carbon Acme threaded screw, spatter resistant
- Unique Bessey® Morpad™ tilts to 35° comes standard with TLY352 and TLY353
- Ergonomic Bessey® grip handle on model TLY352



Model No.	Mfg. No.	Clamping Capacity"	Throat Depth"	Clamping Force (lbs.)	Step-Over"	MorPad™	Bessey® /Grip	Price /Each
TLY351	J18-8	10	4 3/4	880	2 1/4	-	Yes	149.00
TLY352	2400J-12	12	5 1/2	2660	4	Yes	Yes	247.00
TLY353	4800J-20	20	7	4880	6	Yes	-	515.00

LEVER CLAMPS (LC SERIES)

- Large tilting pressure plate
- Secure ratchet mechanism for rapid vibration-resistant clamping
- Torsion-resistant, fixed bracket and pressure plate produced and tempered in one piece for maximum tensile strength and sturdiness



TLV282

Model No.	Mfg. No.	Clamping Capacity"	Throat Depth"	Clamping Force (lbs.)	Price /Each
TLV282	LC4	4	2 3/8	400	101.00
TN207	LC8	8	4	660	126.00
TN205	LC12	12	5 1/2	1200	156.00
TN206	LC20	20	4 3/4	1200	181.00
TLV283	1800L12	10	5 1/2	1800	262.00

MULTI-PURPOSE CLAMPS

- KombiKlamp™ robust Variable Angle Device (VAD) allows for a solid grip on odd shapes - also reverses for spreading
- Ergonomic Bessey® grip offers greater comfort and slides with the T-handle
- Removable screw acts as a slide stop
- Easily converts to a spreading device



Spreading

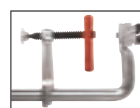

Clamping

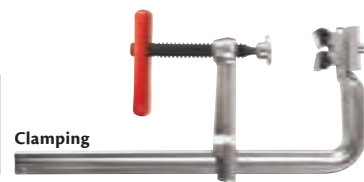

Model No.	Mfg. No.	Clamping Capacity"	Throat Depth"	Clamping Force (lbs.)	Load Limit (lbs.)	Price /Each
TLY350	SG30VAD	11	4.75	2600	3000	165.00

REGULAR-DUTY I BAR CLAMPS NO. 640

- A rapid acting powerful clamp designed and constructed for hard, everyday production work
- Patented, quick action, no slip clutches are 3/4" apart and formed in the web for greater bar strength
- High strength ductile slide cannot slip or bind, easily released
- Steel handle, with comfortable wood crank handle for fast clamping
- Bar dimensions: 7/16" x 1 1/2" x 5/32"
- Screw diameter: 5/8"
- Throat depth: 1 13/16" and clamp face is 1 7/8"



Model No.	Mfg. No.	Opening Capacity	Load Capacity lbs.	Price /Each
TD798	21801	2	6000	125.00
TD800	21803	3	6000	145.00
TD801	21804	4	6000	165.00
TD802	21805	5	6000	185.00
TD803	21806	6	6000	209.00



WELDERS ANGLE CLAMPS

- Automatic adjustment to work pieces of different thicknesses
- Sturdy jaws and base made from high grade cast iron
- Copper plated spindles resist spatter
- Accurate 90° angle



Model No.	Mfg. No.	Jaw Height"	Maximum Material Size for Mitre Joints"	Price /Each
TLV361	WSM9	1 3/8	3 1/2	204.00
TLV362	WSM12	2 2/8	4 3/4	291.00

KANT-TWIST® CLAMPS



Model No.	Mfg. No.	Throat Deep Open"	Throat Deep Closed"	Clamping Capacity"	Clamping Force (lbs.)	Price /Each
ORIGINAL KANT-TWIST®						
TKZ949	1KT	1/2	1/2	1 1/16	300	42.14
TKZ950	2KT	1 1/8	1 1/4	2	700	56.39
TKZ952	3KT	1 1/4	1 3/4	3	1500	72.88
TKZ953	4 1/2KT	2 1/4	2 1/2	4 1/2	1500	77.90
TKZ954	6KT	2 1/8	3 3/8	6	1800	118.76
TKZ955	6DKT	4 5/8	5 1/2	6	1800	128.77

U STYLE BAR CLAMPS

- Light-duty U style bar clamp offers a unique step-over design
- Small, lightweight and very handy
- Rail is made of quality steel drawn in a single piece for durability and strength
- Sliding arm is made of die cast zinc: light, stable and break resistant
- Comes with non-marking plastic caps on both jaws

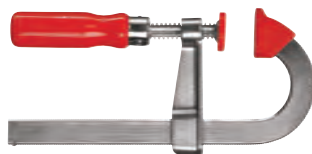

Model No.	Mfg. No.	Clamping Capacity"	Throat Depth"	Clamping Force (lbs.)	Price /Each
TLV358	LMU2.004	4	2	330	9.40
TLV359	LMU2.006	6	2	330	10.60
TLV360	LMU2.008	8	2	330	12.00

QUICK-GRIP® PIPE CLAMPS

- Innovative clutch system eliminates the need for threaded pipe
- Larger feet offer more stability and clearance between handle and worktop
- Larger, more ergonomic handle offers easier clamping with reduced hand fatigue
- Larger clutch plates allow for easier release and increased durability and dependability



Model No.	Mfg. No.	Pipe Size	Throat Depth	Price /Each
TBR730	224134	3/4" (19 mm)	1 7/8" (47 mm)	27.50
TBR731	224212	1/2" (12 mm)	1 1/2" (37 mm)	21.90

PIPE CLAMPS, H STYLE

- H shape foot assembly stabilizes clamp in two dimensions giving dual-axis stability
- Extra high base provides industry leading clearance from the work surface
- Cast jaws for durability
- Smooth action spindle
- Pipe not included



Model No.	Mfg. No.	Pipe Diameter"	Throat Depth"	Price /Each
TLV267	BPC-H34	3/4	1 3/4	28.30
TLV268	BPC-H12	1/2	1 1/2	25.50

QUICK-GRIP® CLUTCH LOCK BAR CLAMPS

- Soft-Grip handle is larger and more ergonomic, allowing high clamping pressure with less effort
- I-beam bar reduces flexing and bowing
- Larger clutch plates allow for easier release, and increase durability and dependability
- 3" throat depth accommodates a variety of projects



Model No.	Mfg. No.	Clamping Capacity	Throat Depth	Price /Each
TBR488	223106	6" (15 cm)	3 1/8" (76 mm)	21.50
TBR424	223112	12" (30 cm)	3 1/8" (76 mm)	22.50
TBR425	223118	18" (45 cm)	3 1/8" (76 mm)	27.90
TBR426	223124	24" (60 cm)	3 1/8" (76 mm)	30.50
TBR427	223136	36" (91 cm)	3 1/8" (76 mm)	36.50

CLUTCH STYLE BAR CLAMPS

- Powder coated, malleable cast iron jaws
- 2-piece slip clutch plates for quick adjustment
- Nickel-plated, drawn serrated rail
- Non-marring pads on the top and bottom jaws to protect work surface
- Ergonomically shaped wood handle

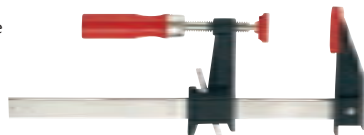

Model No.	Mfg. No.	Clamping Capacity"	Throat Depth"	Clamping Force (lbs.)	Price /Each
TLV269	GSCC2.506	6	2.5	600	16.70
TLV270	GSCC2.512	12	2.5	600	17.70
TLV271	GSCC2.518	18	2.5	600	20.90
TLV272	GSCC2.524	24	2.5	600	23.30
TLV273	GSCC2.530	30	2.5	600	26.10
TLV274	GSCC2.536	36	2.5	600	28.30
TLV278	GSCC5.012	12	5	1200	45.00
TLV279	GSCC5.018	18	5	1200	50.00
TLV280	GSCC5.024	24	5	1200	54.70

JLSD SERIES DEEP THROAT L-CLAMP

- Rail Size: 3/4" x 3/8"



Model No.	Mfg. No.	Clamping Capacity	Throat Depth"	Clamping Force (lbs.)	Price /Each
UAV924	390254	24" (609 mm)	6-3/4	4840	424.00

CLAMPS

BAR CLAMPS FOR CONSTRUCTION & WOODWORKING

PARALLEL BAR CLAMPS K BODY® REVO™

- Large parallel jaw surfaces are made from non-marring polyamide
- Internal steel frames insure 90° angles
- Large composite handle for better comfort while working
- Bessey® anti-slip system for improved grip and safety
- Swivel fitting ensures clamp sits parallel to the bench top
- 3 3/4" throat depth



Model No.	Mfg. No.	Clamping Capacity"	Spreading Capacity"	Price /Each
UAD669	KRE3512	12	10-1/2 to 15-5/16	74.30
UAD670	KRE3524	24	10-1/2 to 28-3/4	83.00
UAD671	KRE3531	31	10-1/2 to 36-1/2	88.00
UAD672	KRE3540	40	10-1/2 to 44-1/2	94.70
UAD673	KRE3550	50	10-1/2 to 52-1/2	101.00
UAD674	KRE3560	60	10-1/2 to 63-3/8	108.00
TKZ910	KRE3582	82	10-1/2 to 81-7/8	118.00
UAD676	KRE3598	98	10-1/2 to 101-1/2	125.00

ACCESSORIES FOR PARALLEL CLAMPS

KP FRAMING SYSTEMS

- Blocks align clamps for door and panel construction
- Clamps sit in grooves to make 90° angles
- Four blocks to a set



Model No. TKZ957
Mfg. No. KP Blocks
Price/Set \$37.60

K BODY® EXTENDERS

- Connects two Bessey® clamps together for extended reach
- Durable aluminum construction
- Includes: Extender, nuts, bolts and washers

Model No. TKZ959
Mfg. No. K Body Extender
Price/Each \$31.80



TG PROFESSIONAL SERIES MALLEABLE CAST CLAMPS

- High quality construction
- Perfect for high pressure applications and wide openings
- Two part composite handle



Model No.	Mfg. No.	Clamping Capacity"	Throat Depth"	Clamping Force (lbs.)	Price /Each
LIGHT-DUTY					
TKZ912	TGJ2.5062K	6	2 1/2	600	30.50
TKZ913	TGJ2.5122K	12	2 1/2	600	32.80
TKZ914	TGJ2.5182K	18	2 1/2	600	36.90
TKZ915	TGJ2.5242K	24	2 1/2	600	38.60
TKZ916	TGJ2.5302K	30	2 1/2	600	43.00
TKZ917	TGJ2.5362K	36	2 1/2	600	48.90
TKZ918	TG4.0082K	8	4	880	39.40
TKZ919	TG4.0122K	12	4	880	46.90
TKZ920	TG4.0162K	16	4	880	51.90
TKZ921	TG4.0242K	24	4	880	55.20

Model No.	Mfg. No.	Clamping Capacity"	Throat Depth"	Clamping Force (lbs.)	Price /Each
MEDIUM-DUTY					
TKZ922	TG4.5122K	12	4 1/2	1000	54.60
TKZ923	TG4.5182K	18	4 1/2	1000	59.20
TKZ924	TG4.5242K	24	4 1/2	1000	66.60
TKZ925	TG4.5302K	30	4 1/2	1000	76.50
TKZ926	TG4.5402K	40	4 1/2	1000	86.90
TKZ927	TG5.5122K	12	5 1/2	1320	60.60
TKZ928	TG5.5182K	18	5 1/2	1320	70.60
TKZ929	TG5.5242K	24	5 1/2	1320	79.30
TKZ932	TG7.0162K	16	7	1320	71.80
TKZ933	TG7.0242K	24	7	1320	85.50
TKZ936	TG7.0482K	48	7	1320	126.00

Model No.	Mfg. No.	Clamping Capacity"	Throat Depth"	Clamping Force (lbs.)	Price /Each
HEAVY-DUTY					
TKZ937	TGK4.5162K	16	4 1/2	1540	70.80
TKZ938	TGK4.5242K	24	4 1/2	1540	81.70
TKZ939	TGK4.5402K	40	4 1/2	1540	103.00
TKZ940	TGK4.5502K	50	4 1/2	1540	121.00
TKZ941	TGK4.5792K	79	4 1/2	1540	167.00

Model No.	Mfg. No.	Clamping Capacity"	Throat Depth"	Clamping Force (lbs.)	Price /Each
DEEP REACH					
TKZ942	CDS24-10WP	24	10	1550	173.00
TKZ943	CDS24-12WP	24	12	1550	199.00
TKZ944	CDS24-20WP	24	20	990	318.00

QUICK-GRIP® ONE-HANDED CLAMPS



BAR CLAMPS/SPREADERS

- Quick-Change® jaw quickly converts from clamp to spreader and requires no tools
- Constructed of high-tech reinforced resin for strength and durability
- Exerts up to 250 lbs. of clamping pressure
- Patented pistol grip design enhances comfort and ease of use
- Non-marring pads grip firmly and protect workpiece
- Ideal for clamping/gluing, holding work for sawing/drilling and positioning work for fastening



MINI BAR CLAMPS

- 25% smaller than Quick-Change® clamps for smaller projects or for working in confined spaces
- Constructed of high-tech reinforced resin for strength and durability
- Exerts up to 150 lbs. of clamping pressure
- Patented pistol grip design enhances comfort and ease of use
- Non-marring pads grip firmly and protect workpiece
- Ideal for clamping/gluing, holding work for sawing/drilling and positioning work for fastening

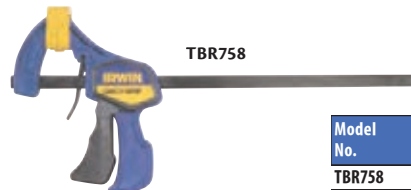

Model No.	Mfg. No.	Clamping Capacity	Spreading Capacity	Throat Depth	Price /Each
TAW063	506QC	6" (15 cm)	7 1/2" - 14 5/8" (195 mm - 360 mm)	3 1/4" (80 mm)	33.50
TAW062	512QC	12" (30 cm)	7 1/2" - 20 5/8" (195 mm - 515 mm)	3 1/4" (80 mm)	37.50
TBR688	518QC	18" (45 cm)	7 1/2" - 26 5/8" (195 mm - 665 mm)	3 1/4" (80 mm)	42.90
TBR689	524QC	24" (60 cm)	7 1/2" - 32 5/8" (195 mm - 820 mm)	3 1/4" (80 mm)	46.50

Model No.	Mfg. No.	Clamping Capacity	Spreading Capacity	Throat Depth	Price /Each
TBR758	5412	12" (30 cm)	-	2 7/16" (62 mm)	20.50

XP™ ONE-HANDED BAR CLAMP & SPREADER

- I-beam bar resists twisting and bowing
- Power Locks™ hold better, allowing for up to 600 lbs. of force
- Quick-Change™ jaw, converts clamp to spreader quickly
- Non-marring pads grip securely
- Quick-Release™ trigger



IRWIN.

Model No.	Mfg. No.	Clamping Capacity	Spreading Capacity	Throat Depth	Price /Each
TKZ880	2021406	6" (15 cm)	7 1/2"-14 5/8" (190 mm-371 mm)	3 1/4" (83 mm)	42.90
TKZ881	2021412	12" (30 cm)	7 1/2"-20 5/8" (190 mm-523 mm)	3 1/4" (83 mm)	47.90
TKZ882	2021418	18" (45 cm)	7 1/2"-26 5/8" (190 mm-676 mm)	3 1/4" (83 mm)	53.50
TKZ883	2021424	24" (60 cm)	7 1/2"-32 5/8" (190 mm-828 mm)	3 1/4" (83 mm)	59.50
TKZ884	2021436	36" (91 cm)	7 1/2"-44 5/8" (190 mm-1133 mm)	3 1/4" (83 mm)	70.90
TKZ885	2021450	50" (127 cm)	7 1/2"-58 5/8" (190 mm-1489 mm)	3 1/4" (83 mm)	80.90

PARALLEL JAW CLAMPS

- Deep 3 3/4" jaw depth for optimized pressure distribution
- Secure locking system prevents jaws from slipping
- ProTouch handle for an ergonomic grip
- Resin body and jaws prevents marring and glue adhesion
- Up to 1150 lbs. of pressure



IRWIN.

Model No.	Mfg. No.	Clamping Capacity	Throat Depth"	Price /Each
TLY300	2026500	24" (60 cm)	3 3/4	73.90
TLY301	2026501	48" (115 cm)	3 3/4	88.50

PARALLEL JAW CLAMPS

- Aluminum die-cast handles have a quick adjustment mechanism for easy sizing
- Serrations in the steel rails engage with a hardened steel insert in the jaw to eliminate slipping
- Clamp jaws are encased in non-marring, glue resistant polypropylene casing
- Clamps up to 2.5 KN of pressure



Model No.	Clamping Capacity"	Throat Width"	Throat Depth"	Price /Each
TYB500	24	1 1/2	3 1/3	74.35
TYB501	50	1 1/2	3 1/3	91.20

AURORA
TOOLS

AURORA
TOOLS

Celebrating
15
YEARS

**EXCEEDING
EXPECTATIONS**



CLAMPS

QUICK-GRIP® C-CLAMPS

- Double-rolled thread for faster clamping and increased durability
- Larger handle for greater clamping pressure with less effort and reduced hand fatigue
- Larger swivel pad reduces marring on work surface and increases stability

Model No.	Mfg. No.	Clamping Capacity	Throat Depth	Price /Each
TBR751	225101	1" (25 mm)	1 3/16" (30 mm)	2.89
TBR752	225102	2" (50 mm)	1 5/16" (33 mm)	4.09
TBR753	225103	3" (75 mm)	2 1/4" (51 mm)	8.39
TBR754	225104	4" (100 mm)	3" (75 mm)	14.50
TBR755	225106	6" (150 mm)	3 1/2" (87 mm)	21.50
TBR756	225108	8" (200 mm)	4" (100 mm)	30.90
TBQ959	225123	2" (50 mm)	3 1/2" (87 mm)	12.90
TBQ960	225134	3" (75 mm)	4 1/2" (120 mm)	19.50



IRWIN®

C-CLAMPS

- Drop forged steel frame
- Lead screw and pad are copper plated to resist welding splatter
- **Limited lifetime warranty**



TYQ473



TYQ475



Model No.	Mfg. No.	Clamping Capacity	Throat Depth	Clamping Force lbs.	Overall Dimensions			Weight lbs.	Price /Each
					L"	x W"	x H"		
TYQ473	C402	2" (50 mm)	1-3/4" (44.45 mm)	3500	7-1/2	x 5	x 1-1/4	1.4	48.90
TYQ474	C403	3" (76 mm)	2-1/2" (63.5 mm)	3500	8-1/4	x 6-1/2	x 2	2.2	55.90
TYQ475	C404	4" (102 mm)	3" (76.2 mm)	6200	11	x 6	x 1	3.3	67.50
TYQ476	C408	8" (203 mm)	4-1/2" (114.3 mm)	6900	15	x 8	x 2	7.4	129.00
TYQ477	C412	12" (305 mm)	5-1/2" (139.7 mm)	9300	22-1/2	x 10-1/2	x 2	12.75	269.00

HI-VIS SAFETY C-CLAMPS

- Coated in high visibility yellow
- Powder coat finish resists scratches and corrosion
- Alloy steel spindles, black oxide coated



TJW241



Model No.	Mfg. No.	Clamping Capacity"	Throat Depth"	Price /Each
TJW241	14300	2-1/8	2-1/4	43.90
TJW242	14301	3	1/1/2	56.90
TJW244	14303	6-1/16	4-1/8	135.00
TJW245	14305	8-1/4	5	175.00
TJW246	14306	10-1/8	6	229.00
TJW247	14307	12-1/4	6-5/16	379.00

C-CLAMPS

- Manufactured from SG iron with over 60000 PSI of tensile strength
- Swiveling pad adapts to the correct angle to apply even pressure on the work piece
- Textured powder coat finish on frame and black oxide finish on spindle increases corrosion resistance



TYB504



Model No.	Clamping Capacity"	Throat Depth"	Min. Proof Test lbs.	Price /Each
TYB502	2	1 5/8	800	15.70
TYB503	3	1 11/16	1000	19.90
TYB504	4	2 11/32	1200	24.95
TYB505	6	3	1400	32.10
TYB506	8	3 1/8	1700	42.10
TYB507	10	3 1/2	2200	54.75
TYB508	12	4	2500	69.95

HOLD DOWN CLAMPS

- Commonly used clamps in manufacturing
- Perfect for holding work pieces in place
- Durable steel construction

VERTICAL HOLD-DOWN CLAMPS

- Includes bonded neoprene-tipped spindle and flanged washers
- Open arm provides adjustable spindle location

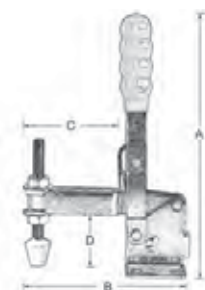

Model No.	Holding Cap. lbs.	Dimensions"				Base			Wt. lbs.	Price /Each
		A	B	C	D	L"	x	W"		
TLV625	200	4	2 1/2	1	1	1	x	1 3/4	0.34	12.90
TLV626	375	6	4 5/8	2 3/4	1 1/4	1 13/16	x	1 7/16	0.65	14.65
TLV627	600	8 1/8	4 13/16	3	1 3/4	1 7/8	x	2 1/2	1.25	17.95

TLV626



HORIZONTAL HOLD-DOWN CLAMPS

- Includes bonded neoprene-tipped spindle and flanged washers
- Low height design is ideal when space is a concern
- Open arm provides adjustable spindle location

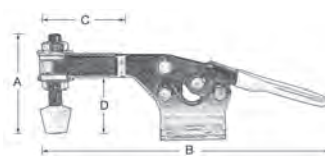

Model No.	Holding Cap. lbs.	Dimensions"				Base			Wt. lbs.	Price /Each
		A	B	C	D	L"	x	W"		
TLV628	200	1 1/16	5 5/8	2 1/4	1	1 7/16	x	1 7/16	0.28	12.90
TLV629	500	1 13/16	6 3/4	2 11/16	1 5/16	1 3/8	x	1 1/2	0.52	14.65

TLV628



LATCH CLAMPS

- Commonly used to hold molds, dies, and jigs together
- Includes latch plate



Model No.	Holding Cap. lbs.	Dimensions"		Base			Wt. lbs.	Price /Each
		A	B	L"	x	W"		
TLV630	360	1 1/4	4	1 1/16	x	1	0.16	14.50
TLV631	700	1 5/8	6 7/8	1 1/2	x	1 11/16	0.55	18.30

TLV630

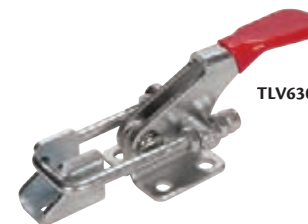

STRAIGHT LINE CLAMPS

- Commonly used in assembly operations or with welding jigs

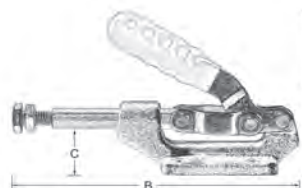

Model No.	Holding Cap. lbs.	Dimensions"			Base			Wt. lbs.	Price /Each
		A	B	C	L"	x	W"		
TLV632	600	3 1/8	5 5/8	1 1/2	1 7/8	x	2 1/4	0.80	24.30
TLV633	300	4 5/16	4 1/2	-	N/A			0.42	22.15

TLV632



TLV633

AUTO-ADJUST TOGGLE CLAMPS

- Automatically adjust to variations in work piece dimensions
- The integrated clamping force adjustment screw can be used to create an actually applied clamping force from 25 to 550 lbs. (max holding capacity of 700 lbs.)
- The large (2 1/4" x 2 1/2") flanged base is designed for use with 1/4" or M6 fasteners
- The removable non-marring plastic cap is included on the 7/8" diameter swivel pads



Model No.	Mfg. No.	Opening"	Clamping Force Range (lbs.)	Holding Capacity (lbs.)	Price /Each
HORIZONTAL TOGGLE CLAMPS					
TNB028	STC-HH20	13/16	25 - 550	450	39.00
TLV284	STC-HH50	1 9/16	25 - 550	700	40.30
TLV285	STC-HH70	2 3/8	25 - 550	700	41.60
INLINE TOGGLE CLAMPS					
TNB029	STC-IHH15	3/8	25 - 550	450	41.60
TLV286	STC-IHH25	5/8	25 - 550	700	42.90

TLV284



TLV286



VISES



OFF-SET BENCH VISES

- Heavy-duty industrial grade vise
- V notched hardened jaws for vertical gripping
- Ideal for tall work pieces
- Hardened anvil striking surface used for forming & shaping
- Safety locking plate in base prevents the vise from slippage
- Mount Type: Fixed



AURORA
TOOLS

Model No.	Jaw Width"	Max. Opening"	Throat Depth"	Price /Each
TYL103	6	6 1/2	4	233.00

UTILITY WORKSHOP VISES

- 80 000 PSI industrial grade ductile iron
- Built in pipe jaws hold round objects
- Hardened anvil striking surface used for forming & shaping
- Safety locking plate in base prevents the vise from slippage
- Mount Type: Swivel



AURORA
TOOLS

Model No.	Jaw Width"	Jaw Opening"	Throat Depth"	Price /Each
TYL097	6	6 1/2	3 4/10	213.00

MULTI-PURPOSE BENCH VISES

- Heavy-duty casting for demanding applications
- Rotating head for gripping at any angle
- Permanent pipe jaws holds round objects
- Hardened anvil striking surface used for forming & shaping
- Safety locking plate in base prevents the vise from slippage
- Mount Type: Swivel



AURORA
TOOLS

Model No.	Jaw Width"	Jaw Opening"	Throat Depth"	Price /Each
TYL102	5	5 1/2	3 1/10	285.00

HEAVY-DUTY FIXED BASE BENCH VISES

- 80 000 PSI industrial grade ductile iron
- Built in pipe jaws hold round objects
- Hardened anvil striking surface used for forming & shaping
- Safety locking plate in base prevents the vise from slippage
- Mount Type: Fixed



AURORA
TOOLS

Model No.	Jaw Width"	Jaw Opening"	Throat Depth"	Price /Each
TYL093	4	4 1/2	2 7/10	208.00
TYL094	5	5 1/2	3 3/10	278.00
TYL095	6	6 1/2	3 1/2	438.00
TYL096	8	8 1/2	4	471.00

HEAVY-DUTY INDUSTRIAL BENCH VISES

- 90 000 PSI drop forged alloy steel construction for top performance
- Perfect parallel jaw design for secure clamping
- Forged pipe jaws hold up to 2 1/2" pipe (TNB035)
- Precision ground and induction hardened jaws and anvil for dependable and long life of vise
- Long length alloy steel spindle handle for fast and high force clamping
- 360° rotation swivel base for versatile positioning of parts



Model No.	Mfg. No.	Jaw Width"	Jaw Opening"	Throat Depth"	Pipe Jaw Capacity"	Price /Each
TNB033	BV-DF4SB	4	4 1/2	2 3/8	1/4 - 3	485.00
TNB034	BV-DF5SB	5	6 1/2	3	1/4 - 4	546.00
TNB035	BV-DF6SB	6	7	4	1/4 - 5	731.00

HEAVY-DUTY SWIVEL BASE BENCH VISES

- 80 000 PSI industrial grade ductile iron
- Built in pipe jaws hold round objects
- Hardened anvil striking surface used for forming & shaping
- Safety locking plate in base prevents the vise from slippage



AURORA
TOOLS

Model No.	Jaw Width"	Jaw Opening"	Throat Depth"	Price /Each
TYL098	4	4 1/2	2 1/2	149.00
TYL099	5	5 1/2	3	199.00
TYL100	6	6 1/2	3 4/10	245.00
TYL101	8	8 3/10	3 8/10	375.00

DRILL PRESS VISE

- Precision ground sides and front side face, permits additional mounting positions for drilling, tapping or reaming
- The body and sides are also ground perfectly parallel and square to further ensure complete jaw alignment
- Combining a smooth moveable jaw plate with a cross-patterned 90° V-groove stationary jaw, the vise is recommended for general use

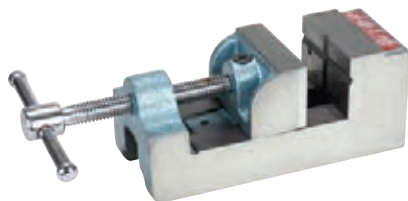

Model No.	Mfg. No.	Jaw Width"	Jaw Opening"	Jaw Depth"	Overall Height"	Price /Each
TM798	25	2 1/2	2 1/2	1 1/2	3 2/3	185.00

VERTI-LOCK® MACHINE VISES

- Jaw widths from 5" up to 8"
- Needle thrust bearing
- Flat bed parallel to 0.0001 per inch
- Ductile steel alloy body parts

SWIVEL BASE

- 360° rotation via two 360° scales
- Calibrated in 1° increments for easy use



WORKSTOP

- Quick, accurate positioning
- Ideal for highly repetitive operations



Model No.	Mfg. No.	Jaw Width"	Jaw Opening"	Type of Base	Price /Each
MACHINE VISES					
TE166	1250N	5	4 1/2	Stationary	1535.00
TE167	1275N	6	7 1/2	Stationary	1769.00
TE168	1280N	8	7 1/2	Stationary	3509.00
SWIVEL BASES					
TE170	5S	5	-	Swivel	439.00
TE171	6S	6	-	Swivel	519.00
TE172	8S	8	-	Swivel	959.00

SUPER PRECISION 2 WAY ANGULAR MACHINE VISES

- Perfect vise for grinding, jig boring and shaping jobs
- Jaw plates hardened and ground
- 90° vertical and 180° horizontal indexing
- 360° swivel base and 90° tilting range



Model No.	Mfg. No.	Jaw Width"	Jaw Opening"	Jaw Depth"	Price /Each
TJW135	AMV/SP-50	2	2	1 5/16	579.00
TJW136	AMV/SP-75	3	3	1 5/16	939.00
TJW137	AMV/SP-100	4	4	1 9/16	1155.00
TJW138	AMV/SP-125	5	5	2	1655.00
TJW139	AMV/SP-150	6	6	2	2075.00

VERSATILE DRILL PRESS VISES

Rugged design and large workload capacity make these vises perfect for the most difficult drilling, tapping or reaming operations.

MODELS VE855, TE622 & E586

- Made of graded cast iron and offers a ground vise bed for a smooth, consistent jaw movement and hardened top U-groove jaws

MODELS VE858 & VE859

- Made of graded cast iron and features precision 90° machining of the vise's sidebodies, which allows them to be used as bases
- Rapid action nut allows for fast loading and unloading of production material and extra tightening capabilities
- Main castings provide extra strength and increased durability



Model No.	Mfg. No.	Jaw Width"	Jaw Opening"	Jaw Depth"	Price /Each
CONTINUOUS NUT					
VE855	1335	3	2 3/4	1 7/8	199.00
TE622	1345	4	4	2 1/8	289.00
VE856	1360	5	5	2 1/8	409.00
RAPID ACTING NUT					
VE858	1445	4 1/2	4 3/4	1 7/8	459.00
VE859	1460	6	6 3/4	2 1/8	639.00

CAM ACTION DRILL PRESS VISES

- Holding pressure is adjustable from 400 to 1100 lbs.
- Recessed parallel steel jaw inserts level work, and can be removed to accommodate your jig and fixture components
- The base is designed for clear through drilling applications
- For added durability, bars and locking mechanisms are hardened and ground
- The unique top locking lever can be raised or lowered to tighten or loosen against the workpiece

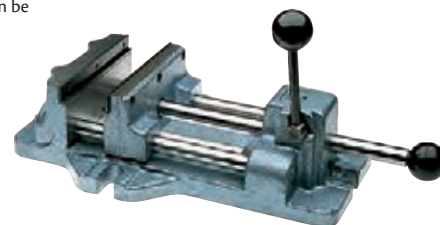

Model No.	Mfg. No.	Jaw Width"	Jaw Opening"	Jaw Depth"	Overall Height"	Price /Each
TE162	1204	4	4 11/16	1 5/16	3 1/4	435.00
TE163	1206	6	6 3/16	1 13/16	3 3/4	755.00
TE164	1208	8	8 3/16	2	4 7/16	939.00

SUPER PRECISION 3 WAY TILTING MACHINE VISES

- Perfect vise for 3 axis jobs in milling, drilling, grinding, shaping and jig boring
- Jaw plates hardened and ground
- Accurately indexed for 3 way angular work
- 90° vertical indexing
- 360° swivel base and 45° tilting range on either side



Model No.	Mfg. No.	Jaw Width"	Jaw Opening"	Jaw Depth"	Price /Each
TJW130	TLT/SP-50	2	2	5/16	805.00
TJW131	TLT/SP-75	3	3	1 5/16	1325.00
TJW132	TLT/SP-100	4	4	1 9/16	1685.00



HEAVY-DUTY BRITISH PATTERN BENCH VISE

- Proven British pattern design is perfect for most industrial applications
- Exclusive integrated anvil provides extra work area for added versatility
- Heavy duty 30 000 PSI ductile iron casting provides excellent strength and high clamping pressures
- CNC machined mating surfaces provide smooth, reliable action
- Micro-grooved hardened replaceable machinist jaws provide safe, secure grip on a variety of materials
- Safety stop prevents jaw from separating from body
- Unbreakable SG Iron vise nut is easily replaced when worn
- Handle bends to warn of overload
- Swivel base available separately
- **Manufacturer's Warranty: Limited Lifetime**



Model No.	Mfg. No.	Jaw Width"	Jaw Opening"	Throat Depth"	Price /Each
UAV907	320334	6	8	3-1/2	362.00
UAV908	320335	8	9	4	479.00

SWIVEL BASE

- 30 000 PSI tensile strength 360° base
- Dual lock down bolts are stronger than T handles
- Provides ultimate versatility for your heavy-duty vise
- Fits model: 6" British Pattern Bench Vise - Heavy-Duty (320334) and 8" British Pattern Bench Vise - Heavy-Duty (320335)



Model No. UAV909
Mfg. No. 320364
Price/Each \$103.00



HIGH VIS SAFETY VISE

- Wilton's safety vises are coated in high visibility yellow
- Safety colour conforms to OSHA standard for physical hazards regulation #1910.144
- Powder durable coat finish
- Corrosion resistant black oxide coated handles and lockdowns
- 30 000 PSI castings
- Meets all Government specifications



Model No.	Mfg. No.	Jaw Width"	Throat Depth"	Price /Each
TD673	63187	5	3-3/4	749.00
TD674	63188	6	4-1/8	1029.00

SHOP VISES

- General-duty use
- Instant-Action™ vise design ensures immediate engagement of the nut and spindle screw
- Vise rotates 360°
- Rubber pinch point safety guards
- 25 000 PSI castings for long life



Model No.	Mfg. No.	Jaw Width"	Jaw Opening"	Throat Depth"	Price /Each
VE839	WS4	4	4	2 3/4	359.00
VE840	WS5	5	5	3	435.00

MECHANIC'S VISES

- Meets all Government specifications
- Replaceable hardened steel serrated jaw inserts and replaceable pipe jaws provide sure grip
- Enclosed, unbreakable box frame, steel channel
- Large anvil
- Swivel base rotated 360° and has double lockdowns ensuring maximum stability
- Straight line design - positions spindle and nut horizontally, reducing thread wear and increasing clamping power
- 30 000 PSI castings for long life and added strength
- Ideal for professional mechanics



Model No.	Mfg. No.	Jaw Width"	Jaw Opening"	Throat Depth"	Pipe Jaw Capacity"	Price /Each
TD669	744	4	4 1/2	3 7/16	1/4 - 2	549.00
TD670	745	5	5 1/4	3 3/4	1/4 - 2 1/2	775.00
TD671	746	6	5 3/4	4 1/8	1/4 - 3 1/2	989.00

TRADESMAN VISES

- Meets all Government specifications
- Replaceable top and pipe jaws
- Provides greater clamping surface
- Large anvil
- Fully enclosed spindle
- Straight line design
- Mounting template and parts list included with every vise
- Precision thrust bearing creates greater clamping pressure and increased longevity
- 60 000 PSI ductile iron
- Top jaws are reversible - either standard serrated jaws for extra grip on sturdier materials or smooth jaws for more delicate pieces
- 360° swivel base



Model No.	Mfg. No.	Jaw Width"	Jaw Opening"	Throat Depth"	Pipe Jaw Capacity"	Price /Each
TD667	1780A	8	7	4 3/4	1/8 - 3 1/2	2435.00

MECHANIC'S VISE

- Lightweight vise precision-cast from 30 000 PSI tensile strength iron
- Precision machined hardened steel jaws
- Built-in pipe jaws
- Large machined anvil
- 360° swivel base with dual lock down handles
- Shot blast finish powder coat paint for protection from corrosion
- Base Type: Swivel



Model No.	Mfg. No.	Jaw Width"	Jaw Opening"	Throat Depth"	Pipe Capacity"	Price /Each
UAV831	024726	6	5	3	2	255.00
UAV832	024728	8	6	3-1/2	2-1/2	365.00

WISE ACCESSORIES

IMPROVE CLAMPING VERSATILITY & SAFETY



WILTON MAGNEFIX VISE JAW CAPS TEMPORARY WORK-HOLDING SYSTEMS

- Designed to protect both the vise jaws and the workpiece from marring and distortion during any clamping application
- Caps are constructed from a hardened aluminum alloy with two built-in circular permanent magnets on the backside which hold the product securely to the vise
- The caps are magnetic towards the vise side to prevent steel filings from attaching themselves to the jaws and keep the clamped part from becoming magnetized

MODEL A - ALUMINUM MAGNEFIX JAW CAPS

- Aluminum alloy design includes six grooves to compensate for the unevenness of the workpiece
- Deeper Vee-Groove ensures more secure clamping of circular work pieces
- Use together with Rubber Magnefix Jaw Caps when clamping taper pins and spherical parts

MODEL F - FIBER FACE MAGNEFIX JAW CAPS

- Aluminum alloy with laminated fiber cover to prevent the absorption of outside materials
- Heat parts rapidly by concentrating heat into part
- Use on workpieces to avoid distortion and clamping marks

MODEL R - RUBBER FACE MAGNEFIX JAW CAPS

- Aluminum alloy with synthetic rubber cover
- Jaw cap conforms to workpiece and grips firmly without slipping while protecting work surface
- Use in combination with aluminum and prism jaw caps to clamp taper pins or tapered workpieces

MODEL P - PRISM MAGNEFIX JAW CAPS

- Jaw construction includes a 120° horizontal Vee-Groove, three vertical Vee-Grooves and a 90° groove for marking out and centre punching
- Ideal for light tapping and thread cutting applications



Model No.	Mfg. No.	Jaw Width"	Price /Each	Model No.	Mfg. No.	Jaw Width"	Price /Each
STANDARD ALUMINUM MAGNEFIX JAW CAPS							
TM832	A-4	4	79.90	TJW079	A-5.5	5 1/2	92.90
TM833	A-4.5	4 1/2	82.50	TM835	A-6	6	92.90
TM834	A-5	5	84.90	TJW081	A-6.5	6 1/2	98.50
FIBER FACE MAGNEFIX JAW CAPS							
TM844	F-4	4	82.50	TM846	F-5	5	90.50
TM845	F-4.5	4 1/2	90.50	TM847	F-6	6	92.90
RUBBER FACE MAGNEFIX JAW CAPS							
TM856	R-4	4	79.90	TJW092	R-5.5	5 1/2	92.90
TM857	R-4.5	4 1/2	84.90	TM859	R-6	6	92.90
TM858	R-5	5	84.90	TJW094	R-6.5	6 1/2	95.90
PRISM MAGNEFIX JAW CAPS							
TM851	P-4	4	87.90	TJW100	P-5.5	5 1/2	105.00
TM850	P-4.5	4 1/2	95.50	TM853	P-6	6	98.50
TM852	P-5	5	95.50	TJW102	P-6.5	6 1/2	105.00

TELESCOPIC MAGNETIC RETRIEVERS

- Ideal for reaching behind, underneath or around machinery and/or difficult to reach areas
- Rare earth magnet material
- Max. temperature of 180° F (82° C)

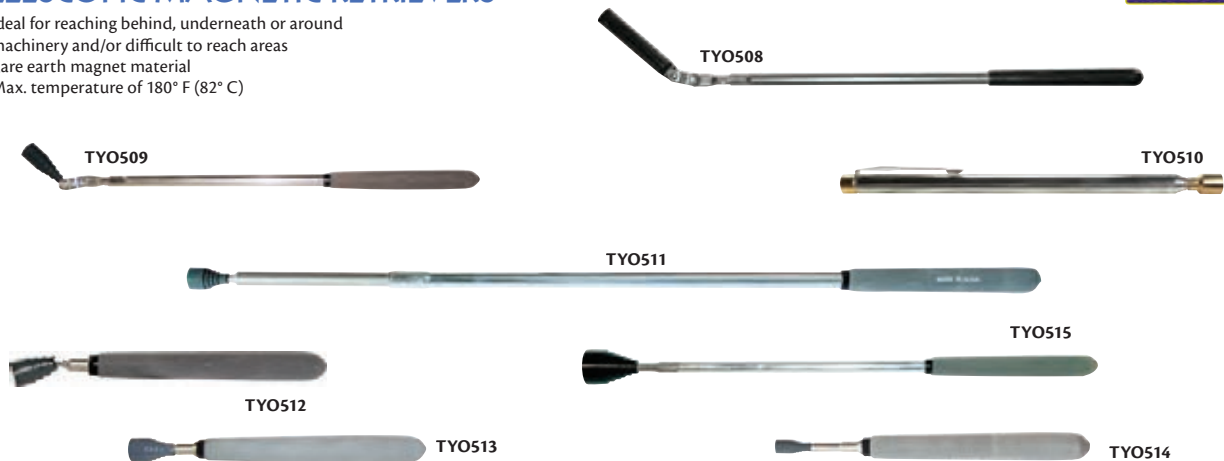

Model No.	Mfg. No.	Strength lbs.	Diameter"	Length"	Extended Length"	Weight lbs.	Price /Each
TYO508	927	7.5	1/2	17	26 1/2	0.36	28.50
TYO509	931	12	1/2	13	26	0.44	41.60
TYO510	240N	2	5/16	5 1/2	25 1/2	0.07	8.53
TYO511	926	14	5/8	23 1/2	50	0.42	58.10
TYO512	925	7	5/8	8	35	0.19	39.30
TYO513	923	5	3/8	6 1/2	32	0.14	24.20
TYO514	924	7	5/8	6 1/2	32	0.18	36.90
TYO515	990SM	20	1 1/8	16 1/2	29	0.65	82.50

NON-SPARKING, NON-MAGNETIC TOOLS



Ampco non-sparking, non-magnetic, corrosion-resistant safety tools are FM approved. Made in the U.S.A. Backed by a limited lifetime warranty. Effectively limit sparking and meet OSHA's New Hazard Communication Standard stating that non-sparking tools are required with flammable liquids. Non-sparking tools for use in locations where flammable vapours and/or combustible residues are present. Non-sparking or intrinsically safe tools are also required and/or recommended by NFPA, MSHA and NIOSH.

Ideal for petroleum, metalworking, paint finishing, and transportation applications. Also used in woodworking, fertilizer production, and grain handling where high levels of dust are prominent. The metals used to make Ampco Safety Tools are

highly conductive and should be grounded if there is a risk for static sparks.

Non-sparking metal - High-strength for impact and torque applications. Brinell hardness is 200 to 350. Tensile strength is 95 000 to 150 000 PSI.

Beryllium Copper* - Superior strength for impact and torque applications. Most effective material for tools with cutting edges or gripping teeth. Brinell hardness is 332 to 382. Tensile strength is up to 200 000 PSI.

* All models made from non-sparking metal, some contain beryllium copper where indicated.



WRECKING & PRYING BARS

Cast from a high-strength nickel-aluminum bronze. Ideal for handling potentially flammable or hazardous items.



Model No.	Description	Bar Size"	Overall Length"	Wt. lbs.	Price /Each
TP415	Hammer/Claw Crate Opener Stock: 3/4"W x 0.339" Thick	2 3/4	9	0.94	97.20
TP416	Nail Puller Shank dia.: 0.705"; Jaw Width: 0.325"		18	4.0	539.00
TP417	Crow Bar	5/8 Hex.	18	1.9	215.00
TP418	Crow Bar	3/4 Hex.	24	3.8	272.00
TP419	Crow Bar	7/8 Hex.	30	6.0	359.00
TP420	Crow Bar	7/8 Hex.	36	7.2	379.00
TP421	Pinch Bar w/Bent Chisel Tip	3/4 Hex.	18	2.3	102.00
TP422	Pinch Bar w/Bent Chisel Tip	7/8 Hex.	30	5.1	275.00
TP423	Pinch Bar w/Bent Chisel Tip	1 Hex.	36	8.7	454.00
TP424	Pry bar w/Straight Chisel Tip	1 1/4	60	18.8	934.00
TP425	Pry bar w/Straight Chisel Tip	1 3/8	68	24.5	1279.00



HAMMERS & MALLETS

Non-sparking metal construction, cast from a high strength nickel-aluminum bronze. Fibreglass handle for durability and vibration control.



Model No.	Description	Head Wt. lbs.	Face Dia."	Overall Length"	Price /Each
BB512	Curved-Claw Nail Hammer Smooth Striking Face	0.75	5/8	14	122.00
BB514	Curved-Claw Nail Hammer Smooth Striking Face	1.00	1	14	130.00
BB517	Curved-Claw Nail Hammer Smooth Striking Face	1.25	1	14	195.00
BB486	Ball Pein Hammer	0.25	3/8	9 3/4	74.20
BB487	Ball Pein Hammer	0.75	1	14	97.20
BB488	Ball Pein Hammer	1.00	1 1/4	14	108.00
BB489	Ball Pein Hammer	1.50	1 3/8	14	122.00
BB490	Ball Pein Hammer	2.00	1 1/4	14	143.00
BB491	Ball Pein Hammer	2.25	1 5/8	14	162.00
BB492	Ball Pein Hammer	2.75	1 3/4	14	165.00
BB498	Double-Face Engineer's Hammer	2.00	1 3/8	14	146.00
BB503	Double-Face Engineer's Hammer	2.25	1 3/8	14	161.00
BB504	Double-Face Engineer's Hammer	2.75	1 1/2	14	196.00
BB509	Double-Face Engineer's Hammer	3.00	1 1/2	14	203.00
WI940	Sledge Hammer	3.00	1 3/4	14	227.00
WI941	Sledge Hammer	6.00	2	33	329.00
WI942	Sledge Hammer	8.00	2 1/4	33	450.00
WI943	Sledge Hammer	10.00	2 3/8	33	558.00
WI944	Sledge Hammer	16.00	2 3/4	33	789.00
WI945	Sledge Hammer	18.00	3	33	1137.00
WI953	Mallet	2.00	1 1/2	14	149.00
WI954	Mallet	4.00	2	15	220.00
WI955	Mallet	6.00	2 1/4	15	351.00
BB497	Bricklayer's Hammer	1.50	3/4	14	198.00
BB541	Scaling Hammer	1.00	1 x 1/8	14	135.00



NON-SPARKING, NON-MAGNETIC TOOLS

CLAY PICKS

Cast from a high strength nickel-aluminum bronze.
Eye opening size is 1 5/8" W x 2 1/2" L. **Fiberglass handle sold separately.**

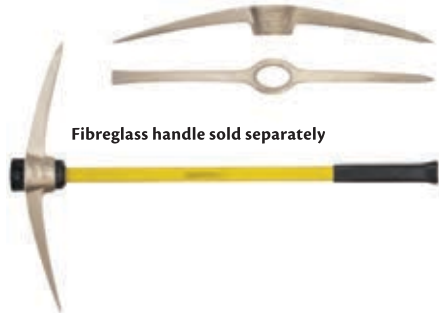

Fiberglass handle sold separately



Model No.	Head Wt. lbs.	Head Length"	Price/Each
TP464	4 1/2	21	352.00
TP465	6 3/4	25	386.00
TP466	10 2/5	27 1/2	902.00
TP467*	Fiberglass Handle	36	66.60

* Fiberglass handle sold separately

SAFETY FLANGE WEDGES

Cast from high strength nickel-aluminum bronze



TLV219



Model No.	Mfg. No.	Dimensions			Price /Each
		L" x W" x H"			
TLV212	W-1	3 1/4 x 1/2 x 1/4			20.70
TLV213	W-2	3 3/4 x 3/4 x 1/2			20.70
TLV214	W-3	6 x 1 x 1/2			28.40
TLV215	W-4	6 x 1 1/2 x 3/4			46.50
TLV216	W-5	7 x 1 1/4 x 1/2			38.90
TLV217	W-6	7 x 2 x 3/4			69.80
TLV218	W-7	7 3/4 x 1 1/2 x 1 5/8			96.00
TLV219	W-8	8 x 1 1/2 x 1			75.30
TLV220	W-9	8 x 2 x 3/4			77.10
TLV221	W-10	8 1/2 x 2 x 1 1/4			103.00
TLV222	W-11	7 x 2 x 3/8			53.50
TLV223	W-12	3 1/2 x 2 x 3/8			36.90
TLV224	W-13	8 x 2 x 2			248.00

SHOVELS & SCOOPS

Non-sparking metal construction. One-piece blade, hollow-socket shovels and scoops. High strength and manageable weight allow for continuous and effective use. Long-handled models have fiberglass handles and D-handled models have fiberglass handles with a plastic grip bar.

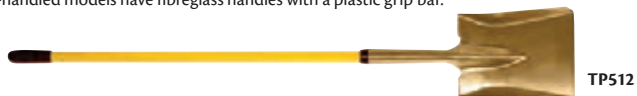

TP512



TP511

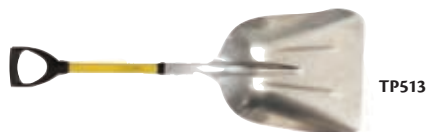

TP513



TP510

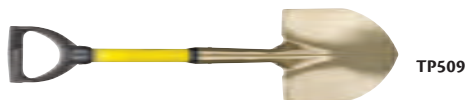

TP509

Model No.	Blade Size			Handle Style	Overall Length"	Price /Each
	W"	x	H"			
ROUND-POINT SHOVELS						
TP509	9	x	11 1/4	D	37	437.00
TP510	9	x	11 1/4	Long	56 1/2	452.00
SQUARE-POINT SHOVELS						
TP511	9	x	11	D	37	502.00
TP512	9	x	11	Long	58	508.00
SCOOP SHOVELS						
TP513	14	x	17	D	40	220.00
TP514	14	x	17	Long	60 1/2	227.00

BANANA WEDGES

- Cast from high strength nickel-aluminum bronze
- Length: 12-1/4"
- Width: 13/16"
- Height: 4-1/16"

Model No. TYO567
Mfg. No. BW-1
Price/Each \$264.00



CHISELS

- Cast from a high strength nickel-aluminum bronze
- Hexagonal shank



HAND CHISELS

Model No.	Tip Width"	Shank Width"	Overall Length"	Price/Each
TP493	1/4	1/4	5 1/4	34.60
TP494	7/16	3/8	5 3/4	46.20
TP495	9/16	1/2	6 1/2	35.60
TP496	3/4	5/8	6	45.80
TP497	13/16	3/4	8	58.80
TP498	11/16	5/8	9 1/8	63.50
TP499	3/4	3/4	9	69.50
TP500	7/8	7/8	9	77.80
TP501	1 1/16	1	9 1/4	93.20
TP502	9/16	1/2	12	60.00
TP503	7/8	3/4	12	83.30
TP504	1	7/8	30	371.00

BOLT CUTTERS



BOLT CUTTERS

- Chrome molybdenum steel jaws
- Centre cutting blades
- Adjusting screws allow for easy and perfect alignment of jaws
- Strong tubular handle with slip-proof rubber grips

OUTILS
AURORA



Model No.	Length"	Max. Jaw Opening"	Price/Each
TJZ111	14	1/4	28.25
TJZ112	18	5/16	39.40
TJZ113	24	3/8	53.35
TJZ114	36	9/16	85.70

INDUSTRIAL GRADE CENTRE CUT CUTTERS

- General plant maintenance tool
- Drop-forged, precision ground, alloy tool steel jaws with centre-cut blades
- Cuts soft, medium, or hard materials
- Maximum hardness of material to be cut: Brinell 455/Rockwell C48
- Lockplate keeps jaws from loosening
- Toggle joints turn 50 lbs. hand pressure to 4000 lbs. cutting pressure
- Screw-type adjustment realigns edges
- Steel handles with rubber grips



CRESCENT
H.K. PORTER

Model No.	Mfg. No.	Wt. lbs.	Overall Length		Cutting Capacity				Price /Each	Replacement Cutterhead		
					Soft and Medium Hard Materials (Up to Brinell 300, Rockwell C31)		Hard Materials (Up to Brinell 455, Rockwell C48)			Model No.	Mfg. No.	Price /Each
			in.	mm	in.	mm	in.	mm				
TBG120	1490MC	2.75	14	356	5/16	8	3/16	5	129.00	TBG109	1413C	148.00
YC552	0090MC	3.5	18	457	3/8	10	1/4	6	142.00	TBF924	0013C	148.00
YC554	0190MC	5.25	24	610	7/16	11	5/16	8	169.00	YC548	0113C	156.00
TBG005	0290MC	8.5	30	762	1/2	13	3/8	10	183.00	TBF983	0213C	195.00
TBG041	0390MC	12.9	36	914	9/16	14	7/16	11	236.00	TBG019	0313C	201.00
TBG082	0590MC	17.2	42	1067	11/16	18	1/2	13	316.00	TBG060	0513C	275.00

GENERAL PURPOSE CENTRE CUT BOLT CUTTERS

- Series 2000 bolt cutter
- Drop-forged jaws with centre-cut blades
- Heat treated for wear resistance and long cutting life
- Cuts soft, and medium/hard materials
- Maximum hardness of material to be cut: Brinell 300/Rockwell C31
- Toggle joints turn 50 lbs. hand pressure to 4000 lbs. of cutting pressure
- Precision cast, 1-piece, aluminum alloy handles with rubber grips



CRESCENT
H.K. PORTER

Model No.	Mfg. No.	Overall Length		Cutting Capacity				Price /Each
				Soft and Medium Hard Materials (Up to Brinell 200, Rockwell C15)		Hard Materials (Up to Brinell 300, Rockwell C31)		
		in.	mm	in.	mm	in.	mm	
UAD568	0090MCP	18-1/2	470	-	-	-	-	77.70
UAD786	0190MCP	26-11/16	678	7/16	11	3/8	10	87.00

GENERAL PURPOSE CENTRE CUT CUTTERS

- All-purpose jaws with centre-cut blades
- Cuts soft, medium, and hard metals
- Maximum hardness of material to be cut: Brinell 455/Rockwell C48
- Lockplate keeps jaws from loosening
- Toggle joints turn 50 lbs. hand pressure to 4000 lbs. cutting pressure
- Screw-type adjustment realigns edges
- Strong, lightweight fiberglass handles
- Popular cutter



CRESCENT
H.K. PORTER

Model No.	Mfg. No.	Wt. lbs.	Overall Length		Cutting Capacity				Price /Each	Replacement Cutterhead		
					Soft and Medium Hard Materials (Up to Brinell 200, Rockwell C15)		Hard Materials (Up to Brinell 455, Rockwell C48)			Model No.	Mfg. No.	Price /Each
			in.	mm	in.	mm	in.	mm				
TBF933	0090FC	3.5	18 1/4	464	3/8	10	1/4	6	248.00	TBF924	0013C	148.00
TBF963	0190FC	4.5	24 1/2	622	7/16	11	5/16	8	295.00	YC548	0113C	156.00
TBG001	0290FC	7.5	30 1/2	775	1/2	13	3/8	10	349.00	TBF983	0213C	195.00
TBG037	0390FC	11.5	36 1/2	927	9/16	14	7/16	11	409.00	TBG019	0313C	201.00

COMPOUND SNIPS

- Designed for all-purpose cutting applications, for home or professional jobsite
- Cuts straight, left or right in light stock
- Latch secures blades for storage
- Rubberized hand grip for quality comfort
- Cutting Capacity: 18-Gauge Steel
- Overall Length: 10-1/4"



AURORA
TOOLS

Model No.	Description	Grip Colour	Length"	Cut Length"	Price /Each
UAE008	Straight Cut	Yellow	10-1/4	1-1/2	24.00
UAE007	Right Cut	Green	10-1/4	1-1/8	24.00
UAE006	Left Cut	Red	10-1/4	1-3/8	24.00

METALMASTER® COMPOUND SNIPS

- **VQ280** Cuts left from tight curves to straight
- **VQ281** Cuts right from tight curves to straight
- **VQ282** Cuts straight, left or right in light stock
- Non-slip serrated jaws



Model No.	Mfg. No.	Grip Colour	Length"	Cut Length"	Recommended Max. Capacity Low Carbon Cold Rolled Steel	Price /Each
VQ280	M1R	Red	9-3/4	1-3/8	18-gauge steel	25.10
VQ281	M2R	Green	9-3/4	1-3/8	18-gauge steel	25.10
VQ282	M3R	Yellow	9-3/4	1-1/2	18-gauge steel	25.10

AVIATION/TIN SNIPS SET

- Hardened alloy steel blades
- Serrated blades prevent material from slipping out of jaws
- Colour-coded soft grip handles for superior grip and user comfort
- No. of Pieces: 3
- Includes: Left cut snips, Right cut snips, Straight cut snips

Model No. UAV826
Mfg. No. 020802
Price/Each \$45.50



METALMASTER® OFFSET SNIPS

- **VQ283** cuts left and straight
- **VQ284** cuts right and straight
- Offset blades keep hands clear of metal
- Non-slip serrated jaw
- Spring-action for fast, effortless feed



CRESCENT
WISS

Model No.	Mfg. No.	Grip Colour	Length"	Cut Length"	Recommended Max. Capacity Low Carbon Cold Rolled Steel	Price /Each
VQ283	M6R	Red	9-1/4	1-1/4	18-gauge steel	31.30
VQ284	M7R	Green	9-1/4	1-1/4	18-gauge steel	31.30

VERTICAL SNIPS

- Right-angle design allows clearance in tight spaces
- Forged blades deliver up to 10X more cuts than cast blades
- Bolt lock ensures the blades won't loosen
- Chrome plating provides rust protection
- Metal lock secures the tool for storage and is easily operated with one hand
- Flush Pivot Bolt
- Ergonomic Grips
- Lanyard Hole
- Cutting Capacity for Stainless Steel: 22-Gauge
- Cut Length: 1-3/20"
- Cutting Capacity: 18-Gauge Steel
- Overall Length: 9"

Milwaukee



Model No.	Mfg. No.	Description	Price /Each
TY199	48-22-4511	Vertical Snips cuts to the left	32.50
TY200	48-22-4521	Vertical Snips cuts to the right	35.20

METALMASTER® BULLDOG SNIPS

- For notching or trimming extra heavy stock
- Non-slip, serrated
- Spring-action for fast, effortless feed



CRESCENT
WISS

Model No.	Mfg. No.	Grip Colour	Length"	Cut Length"	Recommended Max. Capacity Low Carbon Cold Rolled Steel	Price /Each
TBH827	M5R	Red	9-1/4	7/8	16-gauge steel	31.30

AVIATION SNIP SET

- Forged serrated blades with bolt lock
- Flush pivot bolt
- Ergonomic grips
- One-handed metal lock and lanyard hole
- Includes: Left cutting aviation snips, Right cutting aviation snips, Straight cutting aviation snips
- Cut Length: 3"
- Overall Length: 10"
- Handle: Plain
- Cutting Capacity: 22 gauge stainless steel, 18 gauge cold-rolled steel
- Finish: Chrome

Model No. UAF954
Mfg. No. 48-22-4533
Price/Each \$43.90

Milwaukee



SCISSORS & SNIPS

INDUSTRIAL

HEAVY-DUTY INDUSTRIAL SHEARS

- Finest quality cutlery steel
- Black handle standard, cushion grip on some
- Hot drop-forged polished blades
- Patented Set-Easy® pivot



CRESCENT
WISS

Model No.	Mfg. No.	Description	Overall Length"	Cut Length"	Wt. lbs.	Price /Each
UG758	W22N	Black handle	12-1/2	6	1.20	55.70

* Safety point blades

INDUSTRIAL SHEARS

- Often used in the poultry industry
- Made from high quality carbon steel
- Comfortable handle with enlarged lower ring
- Hot drop-forged nickel-plated blades
- Patented Set-Easy® pivot



CRESCENT
WISS

Model No.	Mfg. No.	Description	Overall Length"	Cut Length"	Wt. lbs.	Price /Each
UG766	1DSN	Nickel-plated handle	8-1/2	3	0.42	39.90

INDUSTRIAL SHEARS

- Professional dressmaker and industrial use
- Finest quality cutlery steel
- Comfortable, shaped handle
- Hot drop-forged nickel-plated blades
- Patented Set-Easy® pivot



CRESCENT
WISS

Model No.	Mfg. No.	Description	Overall Length"	Cut Length"	Wt. lbs.	Price /Each
UG763	27N	Black handle	7-1/2	3-1/8	0.19	36.30
UG764	28N	Black handle	8-1/8	3-3/4	0.36	36.30
UG765	29N	Black handle	9-1/4	4	0.48	44.80

10" SHOP SHEARS

- High leverage grip
- 420 stainless blades
- Serrated lower blade
- Heavy-duty blades cut cardboard, heavy fabric, rope, rubber, screen and more

Model No. TKZ886

Mfg. No. W912

Price/Each \$19.40

CRESCENT
WISS



9" EASY SNIP UTILITY SHEARS

- Spring loaded blades, reduce fatigue
- Soft grip handles
- 420 stainless blade
- Wire cutting notch, for light gauge wire
- Safety latch to keep closed when not in use

Model No. TKZ888

Mfg. No. WEZSNIP

Price/Each \$17.00

CRESCENT
WISS



INDUSTRIAL STRAIGHT TRIMMERS

- Designed for industrial use
- Finest quality cutlery steel
- Hot drop-forged nickel-plated blades
- Patented Set-Easy® pivot



CRESCENT
WISS

Model No.	Mfg. No.	Description	Overall Length"	Cut Length"	Wt. lbs.	Price /Each
UG774	37N	Black handle	7-1/8	3-1/8	0.25	36.30

HIGH-LEVERAGE INDUSTRIAL SHEARS

- Finest quality cutlery steel
- One blade ground to knife-edge for faster, cleaner, easier cutting of tough synthetic fibers
- Red cushion grip handles provide maximum leverage
- Hot drop-forged polished blades, safely-rounded for extra protection



CRESCENT
WISS

Model No.	Mfg. No.	Description	Overall Length"	Cut Length"	Wt. lbs.	Price /Each
WJ178	W1225HLSN	Red cushion handle	10-1/4	4-3/4	0.7	63.40

8" TAKE APART UTILITY SCISSORS

- Blades come apart for easy cleaning and sharpening
- Serrated blade
- Semi-circular notch on lower blade, keeps circular items in place when cutting
- Corrosion resistant stainless blades, polypropylene ergonomic grips

Model No. TKZ887

Mfg. No. W8TA

Price/Each \$19.40

CRESCENT
WISS



GENERAL PURPOSE

HIGH-LEVERAGE SHEARS

- Designed for heavy duty cutting
- Used extensively by florists for stem and wire cutting
- Hot drop-forged, commercial quality
- Serrated nickel-plated blades for easy cuts

CRESCENT
WISS



Model No.	Mfg. No.	Description	Overall Length"	Cut Length"	Wt. lbs.	Price /Each
UQ067	2DAN	Black handle	8-1/4	2-1/4	0.56	39.90

8-1/2" GENERAL PURPOSE SCISSORS

- Stainless blades
- Adjustable pivot
- Blades can be resharpened
- Comfortable grip, high leverage bottom ring

Model No. TKZ889

Mfg. No. W812

Price/Each \$12.10

CRESCENT
WISS



SECUMAX 564 SAFETY SCISSORS

- Sharp, but not dangerous
- Comfortable, soft working grip
- Extra-long cutting edges
- Sturdy connection held with a screw
- Cut through cardboard, paper, film, fabric, and more
- Special sharpening of the cutting edges and rounded tips for increased safety
- For use with large hands
- Overall Length: 8-3/5"
- Handle Style: Rings
- Handle Angle: Offset
- Handle Orientation: Ambidextrous
- Blade Material: Stainless Steel

Model No. TCU045
Mfg. No. 564001.00
Price/Each \$63.50



HAND FILES

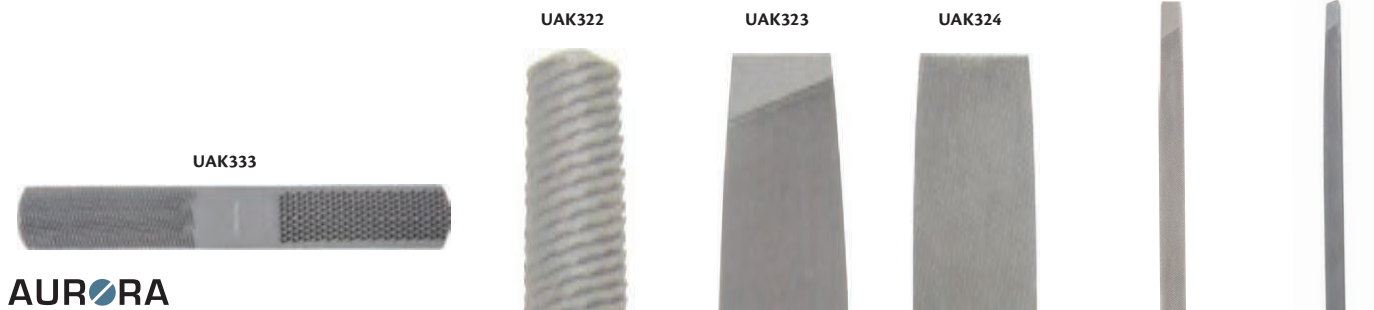

AURORA
TOOLS

Model No.	Shape	L"	Cut Type	Price /Each
WITH HANDLE				
UAU761	Triangle	6	Single	6.70
UAU762	Round	6	Second	7.05
UAU763	Mill	6	Bastard	5.15
UAU766	Mill	8	Bastard	5.95
UAU765	Mill	10	Bastard	7.95
UAU768	Mill	12	Bastard	11.10
UAU767	Mill	8	Smooth	7.15
UAU772	Half Round	8	Bastard	10.70
UAU764	Half Round	10	Bastard	13.20
UAU770	Round	10	Bastard	7.85
UAU771	Flat	8	Bastard	7.30
UAU769	Flat	10	Bastard	9.15

Model No.	Shape	L"	Cut Type	Price /Each
NO HANDLE				
UAK321	Triangle	6	Single	6.35
UAK322	Round	6	Second	6.70
UAK323	Mill	6	Bastard	4.90
UAK326	Mill	8	Bastard	5.65
UAK325	Mill	10	Bastard	7.55
UAK328	Mill	12	Bastard	10.50
UAK327	Mill	8	Smooth	6.80
UAK332	Half Round	8	Bastard	10.15
UAK324	Half Round	10	Bastard	12.50
UAK330	Round	10	Bastard	7.45
UAK331	Flat	8	Bastard	6.90
UAK329	Flat	10	Bastard	8.70
UAK333	Half Round	6	Multiple	7.99

FILE SETS

- General purpose file kits suitable for home and professional use
- Suitable for use on metals, mild steel, iron, plastics, stainless steel, hard rubber, and wood

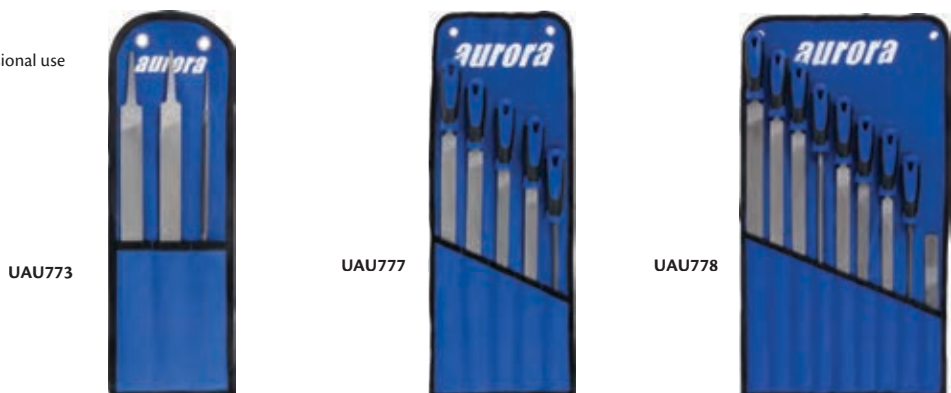

AURORA
TOOLS

Model No.	Description	Includes	Price /Each
UAU773	3-Piece Kit	6" Slim taper file, 10" Mill bastard file, 10" Half round bastard file	18.60
UAU776	3-Piece Kit with Handles	6" Slim taper file, 10" Mill bastard file, 10" Half round bastard file	24.60
UAU774	5-Piece Kit	6" Slim taper file, 8" Mill bastard file, 8" Smooth mill file, 10" Mill bastard file, 10" Half round bastard file	48.30
UAU777	5-Piece Kit with Handles	6" Slim taper file, 8" Mill bastard file, 8" Smooth mill file, 10" Mill bastard file, 10" Half round bastard file	54.40
UAU775	9-Piece Kit	6" Slim taper file, 8" Flat bastard file, 8" Half round bastard file, 10" Mill bastard file, 10" Flat bastard file, 10" Half round bastard file, 10" Round bastard file, 12" Mill bastard file, 4-in-1 Rasp & file combination	95.00
UAU778	9-Piece Kit with Handles	6" Slim taper file, 8" Flat bastard file, 8" Half round bastard file, 10" Mill bastard file, 10" Flat bastard file, 10" Half round bastard file, 10" Round bastard file, 12" Mill bastard file, 4-in-1 Rasp & file combination	105.00



HANDY FILES

- One side is single-cut for use in tool sharpening and smoothing metal surfaces, reverse side is double-cut for general filing and rapid stock removal
- Rectangular shape
- 1 cut edge, 1 safe edge
- Length measured exclusive of handle

CRESCENT NICHOLSON



Model No.	Mfg. No.	Length"	Price/Each
TBG796*	06601	8	16.60
TBG797	06602	8	16.40

*Carded

FLAT FILES

- Used by machinists, machinery builders, ship and engine builders, repairman and others who require rapid removal of metal
- Rectangular in cross section and taper slightly towards point in width
- Double-cut on sides, single-cut on edges
- American pattern, available in bastard, second and smooth-cut

CRESCENT NICHOLSON



Length"	Bastard Cut			Second Cut			Smooth Cut		
	Model No.	Mfg. No.	Price /Each	Model No.	Mfg. No.	Price /Each	Model No.	Mfg. No.	Price /Each
4	VS468	03367	10.20	-	-	-	VS481	03434	12.80
6	VS469	03467	10.90	-	-	-	VS482	03533	13.70
8	VS470	03566	13.50	VS477	03599	14.90	VS483	03632	15.90
10	VS471	03665	16.40	VS478	03698	19.20	VS484	03731	21.40
12	VS472	03764	22.90	VS479	03797	25.80	VS485	03830	28.60
14	VS473	03863	31.90	-	-	-	VS486	03929	40.10
16	VS474	03980	42.00	-	-	-	-	-	-

HALF ROUND FILES

- Used on concave, convex and flat surfaces
- Rounded on 1 side, flat on opposite
- Backs of all half-round bastard files are double-cut
- Backs of all half-round second-cut files longer than 6" are double-cut
- Backs of all 4 and 6" files are single-cut
- Backs of all half-round smooth files are single-cut
- Flat sides of all half-round files are double-cut

CRESCENT NICHOLSON



Length"	Bastard Cut			Second Cut			Smooth Cut		
	Model No.	Mfg. No.	Price /Each	Model No.	Mfg. No.	Price /Each	Model No.	Mfg. No.	Price /Each
4	VS487	04695N	16.20	VS494	04729N	18.00	VS500	04762N	18.90
6	VS488	04795N	16.80	VS495	04828NN	18.10	VS501	04861N	18.80
8	VS489	04896N	20.30	VS496	04927N	21.30	VS502	04960N	22.80
10	VS490	04995N	25.30	VS497	05026N	27.50	VS503	05059N	28.90
12	-	-	-	VS498	05125N	35.30	VS504	05158N	37.20

HAND FILES

- Rectangular shape
- Double-cut
- 1 safe edge
- Same coarseness as flat files of corresponding lengths

CRESCENT NICHOLSON



Length"	Bastard Cut			Second Cut			Smooth Cut		
	Model No.	Mfg. No.	Price /Each	Model No.	Mfg. No.	Price /Each	Model No.	Mfg. No.	Price /Each
6	TBG785	05738N	12.30	TBG786	05771N	13.20	-	-	-
8	TBG788	05853N	13.60	QF890	05886N	16.30	TBG789	05919N	16.70
10	TBG790	05968N	19.30	-	-	-	TBG791	06034N	23.80
12	TBG792	06084N	27.20	TBG793	06117N	29.30	TBG794	06150N	31.00

KNIFE FILES

- Used primarily by tool and die makers with work having acute angles
- Triangular shape
- Double-cut on sides, single-cut on sharp edge
- Knife files are supplied with safe backs

CRESCENT NICHOLSON



Length"	Bastard Cut			Second Cut			Smooth Cut		
	Model No.	Mfg. No.	Price /Each	Model No.	Mfg. No.	Price /Each	Model No.	Mfg. No.	Price /Each
4	TBG801	06711	19.90	-	-	-	TBG803	06773	20.90
6	TBG804	06804	22.80	TBG805	06836	25.20	TBG806	06867	28.00
8	TBG807	06898	27.10	TBG808	06930	29.30	TBG809	06961	30.50
10	TBG810	06992	32.00	-	-	-	TBG812	07054	36.50
12	TBG813	07085	39.60	-	-	-	-	-	-

MILL FILES

- Used for sharpening mill or circular saws
- Also for draw-filing and finishing metals
- Rectangular shape
- Single-cut on sides and edges
- 2 square edges
- All sizes taper slightly in width

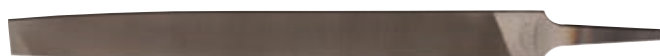

Length"	Bastard Cut			Second Cut			Smooth Cut		
	Model No.	Mfg. No.	Price /Each	Model No.	Mfg. No.	Price /Each	Model No.	Mfg. No.	Price /Each
4	V5518	08243N	7.44	-	-	-	V5529	08306N	11.10
6	V5519	08354N	7.34	V5525	08385N	10.50	V5530	08416N	11.40
8	V5520	08497N	8.90	V5526	08529N	11.80	V5531	08560N	13.40
10	V5521	08642N	11.50	V5527	08673N	15.10	V5532	08704N	15.80
12	V5522	08737N	18.80	V5528	08768N	19.80	V5533	08799N	22.20
12	TBH214*	021842HN	20.50	-	-	-	-	-	-
14	V5523	08832N	24.90	-	-	-	V5534	08894N	31.00

*Indicates ergonomic handle

SQUARE FILES

- Used on slots, keyways and general surface filing
- Square shape
- Double-cut
- Tapered slightly towards point
- Larger sizes frequently preferred to corresponding flat files because of heavier section and 4 filing surfaces



Length"	Dia."	Bastard Cut			Second Cut			Smooth Cut		
		Model No.	Mfg. No.	Price /Each	Model No.	Mfg. No.	Price /Each	Model No.	Mfg. No.	Price /Each
4	5/32	V5557	12790	11.70	-	-	-	V5568	12857	13.80
6	1/4	V5558	12967	12.30	-	-	-	V5569	13033	14.50
8	5/16	V5559	13081	14.70	-	-	-	V5570	13147	16.80
10	3/8	V5560	13196	19.50	-	-	-	V5571	13262	21.90
12	1/2	V5561	13310	27.50	-	-	-	V5572	13376	33.90

ROUND FILES

- Primarily used to file circular openings or concave surfaces
- Round shape
- All 4, 5, 6, 8, 10, 12" files are single-cut
- 14" bastard file is double-cut
- Tapered slightly towards point



Length"	Dia."	Bastard Cut			Second Cut			Smooth Cut		
		Model No.	Mfg. No.	Price /Each	Model No.	Mfg. No.	Price /Each	Model No.	Mfg. No.	Price /Each
4	1/8	V5538	11526N	8.40	-	-	-	V5552	11592N	10.00
6	1/4	V5540	11716N	8.50	V5547	11748N	9.70	V5553	11781N	10.60
8	5/16	V5541	11904	10.30	V5548	11936	11.70	V5554	11969	13.10
10	3/8	V5542	12019	13.30	V5549	12051	15.60	V5555	12084	17.30
12	1/2	TBG829	12131	19.30	-	-	-	-	-	-
12	1/2	V5543	12134	18.40	V5550	12166	21.00	V5556	12199	22.80
14	5/8	V5544	12248	26.20	-	-	-	-	-	-

TAPER FILES – REGULAR

- Triangular shape
- Edges set and cut for filing gullets between saw teeth
- Tapers slightly towards the point



Model No.	Mfg. No.	Length"	Price /Each
V5576	13807M	6	8.40
V5578	13875M	8	12.90

TAPER FILES – SLIM

- Triangular shape
- Edges set and cut for filing gullets between saw teeth



Model No.	Mfg. No.	Length"	Price /Each
V5582	14162M	5	6.02
V5583	14224M	6	6.75
V5584	14255M	7	8.40
V5585	14290M	8	10.00
V5586	14341N	10	13.60

TAPER FILES – EXTRA SLIM

- Triangular shape
- Edges set and cut for filing gullets between saw teeth



Model No.	Mfg. No.	Length"	Price /Each
V5587	14547M	4	6.85
V5589	14599M	5	6.60
V5590	14665M	6	7.25
V5592	14729N	8	10.00

FILES

8-PIECE MACHINIST FILE SET

- 10"/250 mm mill bastard file
- 10"/250 mm half-round bastard file
- 10"/250 mm flat bastard file
- 10"/250 mm flat smooth file
- 10"/250 mm square bastard file
- 10"/250 mm round bastard file
- 7"/175 mm slim taper file
- 10"/250 mm file cleaner (card)
- Complete set of 7 files and file cleaner (card) fits easily and securely into a rugged, compact pouch

Model No. QH790
Mfg. No. 22025NN
Price/Each \$152.00



3-FILE PACK

- For home and professional use
- Pack contains files for every purpose
- 6"/150 mm slim taper file
- 6"/150 mm round file
- 6"/150 mm mill bastard file
- Plastic pouch lists suggested uses for each file
- Pack measures 3 1/2" (88 mm) x 9 1/2" (237 mm) with hang up hole

Model No. TBG941
Mfg. No. 22015NN
Price/Each \$26.70



9-PIECE MAINTENANCE FILE SET

- For home and professional use
- 10"/250 mm flat bastard file
- 10"/250 mm flat smooth file
- 10"/250 mm mill bastard file
- 10"/250 mm half-round bastard file
- 10"/250 mm round bastard file
- 8"/200 mm flat smooth file
- 8"/200 mm half-round bastard file
- 8"/200 mm four-in-hand file
- 6"/150 mm slim taper file
- Complete set of 9 files fits easily and securely into rugged, compact pouch

Model No. TBG944
Mfg. No. 22030NN
Price/Each \$165.00



JET-KUT® PREMIUM FILE SET

- Designed for general maintenance, rapid material removal, blade sharpening, removing sharp edges and burs, rounding holes and smoothing rough surfaces
- Double heat treated forged steel for durability
- High chrome content increases hardness and strength
- Fits securely into durable vinyl pouch
- No. of Files: 9
- Includes:
 - 531410 10" Half Round Bastard, 531510 10" Mill Bastard, 531310 10" Flat Bastard, 531350 10" Flat Smooth, 531610 10" Round Bastard, 531408 8" Half Round Bastard, 531308 8" Flat Bastard, 531508 8" Mill Bastard, 532522 6" Slim Taper

Model No. UAV991
Mfg. No. 532851
Price/Each \$122.00



6-PIECE AMERICAN PATTERN FILE SET

- 4"/100 mm Warding file
- 4"/100 mm Half-Round file
- 4"/100 mm Round file,
- 4"/100 mm Hand file,
- 4"/100 mm Square file
- 4"/100 mm Slim taper file,
- All files come with handles and packed in a plastic pouch

Model No. TBG947
Mfg. No. 22062NN
Price/Each \$71.10



5-PIECE GENERAL PURPOSE SET

- General purpose file kit for home and professional use
- 10"/250 mm half-round bastard file
- 10"/250 mm mill bastard file
- 8"/200 mm mill bastard file
- 8"/200 mm mill smooth file
- Set of 5 files fits easily and securely into rugged, compact pouch

Model No. TBG946
Mfg. No. 22040NN
Price/Each \$69.20



3-PIECE ERGONOMIC FILE SET

- Rubber-coated ergonomic handles for better comfort and control
- Basic selection for home and professional use
- Includes: 6"/150 mm mill bastard file, 6"/150 mm half-round bastard file, 6"/150 mm round bastard file

Model No. UAJ434
Mfg. No. 22015HNNN
Price/Each \$39.80



5-PIECE ERGONOMIC FILE SET

- Rubber-coated ergonomic handles for better comfort and control
- General purpose selection for home and professional use
- 6"/150 mm slim taper file
- 8"/200 mm flat bastard file
- 8"/200 mm mill bastard file
- 10"/250 mm mill bastard file
- 10"/250 mm half-round bastard file

Model No. TBH218
Mfg. No. 22040HNN
Price/Each \$77.90



9-PIECE ERGONOMIC FILE SET

- Rubber-coated ergonomic handles for better comfort and control
- Broad selection for home and professional use
- 6"/150 mm XXslim taper file
- 6"/150 mm slim taper file
- 8"/200 mm half-round bastard file
- 8"/200 mm flat bastard file
- 10"/250 mm round bastard file
- 10"/250 mm half-round bastard file
- 10"/250 mm mill bastard file
- 10"/250 mm flat bastard file
- 12"/300 mm mill bastard file

Model No. TBH217
Mfg. No. 22030HNN
Price/Each \$182.00





TJZ032



TJZ037



TJZ042



TJZ033



TJZ038



TJZ043



TJZ034



TJZ039



TJZ044



TJZ035



TJZ040



TJZ045



TJZ036



TJZ041



TJZ046

2-PC. HICKORY HANDLE HAMMER SETS

Includes:

- TJZ033 Hickory Handle, 16-oz. Claw Hammer
- TJZ034 Hickory Handle, 22-oz. Framing Hammer

Model No. TLV114

Price/Each \$38.94

4-PC. DEAD BLOW HAMMER SETS

Includes:

- TJZ035 Dead Blow, 8-oz. Hammer
- TJZ036 Dead Blow, 16-oz. Hammer
- TJZ037 Dead Blow, 24-oz. Hammer
- TJZ038 Dead Blow, 32-oz. Hammer

Model No. TLV113

Price/Each \$74.03

4-PC. BALL PEIN HAMMER SETS

Includes:

- TJZ039 Ball Pein, 8-oz. Hammer
- TJZ040 Ball Pein, 16-oz. Hammer
- TJZ041 Ball Pein, 24-oz. Hammer
- TJZ042 Ball Pein, 32-oz. Hammer

Model No. TLV112

Price/Each \$74.20

4-PC. RUBBER MALLET SET

Includes:

- TJZ043 Mallet, 16-oz., Black
- TJZ044 Mallet, 32-oz., Black
- TJZ045 Mallet, 16-oz., White
- TJZ046 Mallet, 32-oz., White

Model No. TLV115

Price/Each \$44.11

8-PC. UNIVERSAL HAMMER SETS

Includes:

- TJZ032 Tubular Handle, 16-oz. Claw Hammer
- TJZ034 Hickory Handle, 22-oz. Framing Hammer
- TJZ036 Dead Blow, 16-oz. Hammer
- TJZ038 Dead Blow, 32-oz. Hammer
- TJZ040 Ball Pein, 16-oz. Hammer
- TJZ042 Ball Pein, 32-oz. Hammer
- TJZ044 Mallet, 32-oz., Black
- TJZ045 Mallet, 16-oz., White

Model No. TLV116

Price/Each \$137.00

15-PC. ULTIMATE HAMMER SETS

Includes:

- TJZ032 Tubular Handle, 16-oz. Claw Hammer
- TJZ033 Hickory Handle, 16-oz. Claw Hammer
- TJZ034 Hickory Handle, 22-oz. Framing Hammer
- TJZ035 Dead Blow, 8-oz. Hammer
- TJZ036 Dead Blow, 16-oz. Hammer
- TJZ037 Dead Blow, 24-oz. Hammer
- TJZ038 Dead Blow, 32-oz. Hammer
- TJZ039 Ball Pein, 8-oz. Hammer
- TJZ040 Ball Pein, 16-oz. Hammer
- TJZ041 Ball Pein, 24-oz. Hammer
- TJZ042 Ball Pein, 32-oz. Hammer
- TJZ043 Mallet, 16-oz., Black
- TJZ044 Mallet, 32-oz., Black
- TJZ045 Mallet, 16-oz., White
- TJZ046 Mallet, 32-oz., White

Model No. TLV117

Price/Each \$240.00

AURORA
TOOLS

HAMMERS

POLYURETHANE DEAD BLOW HAMMERS

- Delivers excellent striking force with minimal rebound from the striking surface
- Steel handle welded to head assembly for strength and durability
- Textured rubber handle with flared butt-end for improved grip
- Resistant to gas, brake fluid, anti-freeze and other solvents
- Polyurethane head is resistant to cuts, splits and abrasions



TYX066

GW GEARWRENCH

Model No.	Mfg. No.	Head Weight oz.	Overall Length"	Price Each
TYX066	82240	18	11 3/10	29.80
TYX067	82241	24	12	34.00
TYX068	82242	33	13 1/2	39.90
TYX069	82243	49	14 1/2	50.90
TYX070	82244	54	14 1/2	59.30

SOFT FACE HAMMERS



TYP425

GT GRAY TOOLS

Model No.	Mfg. No.	Head Weight oz.	Head Diameter"	Overall Length"	Price Each
TYP425	SPS150	16	1 1/2	12 1/2	42.90
TYP426	SPS200	24	2	13 3/4	52.90

Note: Tips are not included with hammers. See below.

DEAD BLOW HAMMER

- Non marring and no bounce



TYP429

GT GRAY TOOLS

Model No.	Mfg. No.	Head Weight oz.	Overall Length"	Price Each
TYP429	STPG-24	24	12 1/4	58.50

DEAD BLOW HAMMERS

- 1-piece urethane construction
- Completely enclosed steel shank
- Shot-filled head
- Hi-Viz orange colour



TJZ035

AURORA
TOOLS

Model No.	Weight oz.	Price /Each
TJZ035	8	15.45
TJZ036	16	16.20
TJZ037	24	18.30
TJZ038	32	20.90

RUBBER MALLETS

- Hardwood handle
- Non-marking white rubber head (TJZ045 and TJZ046)



TJZ043



TJZ045

AURORA
TOOLS

Model No.	Weight oz.	Colour	Price /Each
TJZ043	16	Black	7.95
TJZ044	32	Black	10.35
TJZ045	16	White	9.95
TJZ046	32	White	13.95

TIPS FOR SOFT FACE HAMMERS

GT GRAY TOOLS



Model No.	Mfg. No.	Face Diameter"	Hardness	Thread Size"	Colour	Price /Each
TYP438	15S	1-1/2	Soft	5/16	Brown	19.90
TYP436	15M	1-1/2	Medium, Soft	5/16	Red	19.90
TYP445	15T	1-1/2	Soft, Tough	5/16	Green	19.50
TYP447	15XH	1-1/2	Extra-Hard, Soft	5/16	Yellow	30.90
TYP442	15SS	1-1/2	Soft, Super-Soft	5/16	Grey	28.90
TYP434	15H	1-1/2	Hard	5/16	Black	27.50
TYP455	20S	2	Soft	5/16	Brown	28.90
TYP453	20M	2	Medium, Soft	5/16	Red	29.90
TYP462	20T	2	Soft, Tough	5/16	Green	29.50
TYP456	20SN	2	Medium-Hard, Soft	5/16	Cream	43.50
TYP464	20XH	2	Extra-Hard, Soft	5/16	Yellow	47.90
TYP459	20SS	2	Soft, Super-Soft	5/16	Grey	43.50
TYP451	20H	2	Hard, Soft	5/16	Black	43.50

AURORA
TOOLS

Celebrating
15
YEARS

EXCEEDING EXPECTATIONS

STEEL HANDLE HAMMERS

AURORA
TOOLS

TUBULAR HANDLE HAMMERS

- 1.4 mm hardened tubular steel shaft
- Fully polished heat-treated face with octagonal neck
- Shock-absorbing cushion grip handle
- Steel overstrike ring
- Meets ANSI standards



TJZ032

Model No.	Type	Head oz.	Price /Each
TJZ032	Claw	16	11.95

MILLED FACE FRAMING HAMMER

- Shockshield™ handle
- Magnetic nail set
- Face Finish: Checkered
- Handle Type: Solid Steel
- **Tool Warranty: limited lifetime**



TYX834

Model No.	Mfg. No.	Head Weight oz.	Overall Length"	Price /Each
TYX834	48-22-9016	17	16-1/8	60.90
TYX836	48-22-9022	22	15	53.50

SMOOTH FACE FRAMING HAMMER

- Shockshield™ handle
- Magnetic nail set
- Head Weight: 17 oz.
- Face Finish: Plain
- Handle Type: Solid Steel
- Overall Length: 16-1/8"
- **Tool Warranty: limited lifetime**



TYX835

Model No.	Mfg. No.	Head Weight oz.	Overall Length"	Price /Each
TYX835	48-22-9017	17	16-1/8	64.50
TYX837	48-22-9023	22	15	53.50

CLAW HAMMER



TYP397

GRAY TOOLS

Model No.	Mfg. No.	Head Weight oz.	Overall Length"	Price /Each
TYP397	GS-16	16	13	59.90
TYP398	GS-20	20	13-1/4	75.50

FATMAX® GRAPHITE FRAMING HAMMER

- Jacketed graphite core adds strength and durability in the handle while providing the "feel of wood"
- Forged and heat-treated head for durability
- Flared head design provides a large strike surface for optimal nail-driving performance
- Magnetic Nail Start feature for extended reach for one-handed nailing
- Checkered face design increases control and accuracy when driving nails
- Handle Type: Graphite
- Overall Length: 18-1/2"



Model No.	Mfg. No.	Face Finish	Head Weight oz.	Price /Each
UAJ297	51-021	Checkered	22	60.90

STANLEY

WOOD HANDLE HAMMERS

AURORA
TOOLS

HICKORY HANDLE HAMMERS

- Large natural colour, American hickory handle
- Extra tough, heat-treated fully polished head
- Extra large striking face
- Natural shock absorbing qualities of natural wood
- Meets ANSI standards



TJZ033

Model No.	Type	Head oz.	Price /Each
TJZ033	Claw	16	14.95
TJZ034	Framing	22	24.53

FRAMING HAMMERS

- Precision balanced design and naturally shock absorbing American hickory handle increases driving performance
- Magnetic nail set
- Features an axe-style curved handle that gives you a better, more comfortable grip on the hammer as well as an anti-ringing claw
- Head Weight: 19 oz.
- Handle Type: Wood
- Overall Length: 16"



UAE085

Model No.	Mfg. No.	Face Finish	Price /Each
UAE085	48-22-9419	Checkered	44.70
UAE086	48-22-9519	Plain	41.50

Milwaukee

GENERAL PURPOSE HAMMER

- Utilizes vibration dampening slot technology, coupled with a vibration control handle made from proprietary materials to minimize vibration when striking by 70%
- Optimized strike face with 15% larger sweet spot to prevent miss hit and provide greater impact
- Magnetic nail starter holds nails securely under the hammer head for quick and easy one hand nail starting
- Textured fawn's foot grip gives users an ergonomically sound and sure grip on the hammer
- Precision-balanced design with precise weight distribution leads to better accuracy and amplifies force of each swing
- Packaging is recyclable
- Face Finish: Plain
- Handle Type: Cushion
- Overall Length: 14"



UAV733

CRESCENT

Model No.	Mfg. No.	Head Weight	Price /Each
UAV733	CHSGP16-06	16 oz.	30.80
UAV735	CHSGP20	20 oz.	33.80

BALL PEIN HAMMERS

AURORA
TOOLS

- Kiln-dried hickory handle
- High quality construction
- Natural shock-absorbing qualities of natural wood
- Meets ANSI standards



Model No.	Head Wt. oz.	Overall Length"	Price /Each
TJZ039	8	11 1/4	13.95
TJZ040	16	13 7/8	19.45

Model No.	Head Wt. oz.	Overall Length"	Price /Each
TJZ041	24	15 3/16	24.95
TJZ042	32	15 1/8	30.95

HAMMERS

BALL PEIN HAMMER

- High-quality hickory handle
- Forged, new treated head
- Head secured with wood and steel wedges
- Handle Type: Wood



Model No.	Mfg. No.	Head Weight oz.	Overall Length"	Price /Each
TV681	D20805	8	12	31.50
TV682	D21205	12	12	32.90
TV683	D21605	16	14	37.50
TV684	D22405	24	16	42.90
TV685	D23205	32	16	49.50
TV686	D24005	40	16	58.50
TV687	D24805	48	16	66.50

BALL PEIN HAMMERS

- Head Material: Steel
- Standard Met: ANSI



Model No.	Mfg. No.	Handle Type	Head Weight	Face Finish	Overall Length"	Price /Each
AYW112	740105	Steel	24 oz.	Polished	13-1/2	62.90
AYW113	740158	American Hickory	40 oz.	Plain	15-3/4	47.10

BALL PEIN HAMMERS WITH FORGED HANDLE



Model No.	Mfg. No.	Head Weight oz.	Overall Length"	Price /Each
TYP400	2085	8	10 1/2	37.90
TYP401	2125	12	10 1/4	40.50
TYP402	2165	16	13	53.90
TYP403	2245	24	13 1/2	59.90
TYP404	2325	32	14 1/2	66.50

Garant

INDESTRUCTIBLE HANDLE HAMMERS

- Indestructible handle is made up with spring steel bars, encased in rubber, running through the handle
- Spring steel bars are locked into the hammer head with steel locking plates, ensuring it never dislodges
- Ergonomic rubber grip handle absorbs impact and vibration reducing user fatigue
- Will not break, bend, or split even after repeated overstrikes
- Head is induction case hardened S2-S6 HRC
- Meets ANSI BS 876 standard for material hardness and performance



Model No.	Head Weight lbs.	No. of Spring Steel Bars	Handle Length"	Price /Each
SLEDGE HAMMERS				
TYB494	6	6	24	161.00
TYB495	8	6	24	170.00
TYB496	8	6	30	185.00
TYB497	10	6	30	205.00
TYB498	12	6	30	227.00
TYB499	14	6	30	241.00
CLUB HAMMERS				
TYB492	4	4	12	85.00
TYB493	4	4	16	102.00

AURORA TOOLS

Celebrating **15 YEARS**

EXCEEDING EXPECTATIONS

SUPER HEAVY-DUTY CLUB HAMMER

- All-steel handle is virtually immune to overstrikes
- 1055 medium carbon steel head hardened and tempered to prevent chipping or mushrooming
- Sand blast finish with fully polished striking faces
- TPR handle grip absorbs shock and provide excellent grip
- Handle grip riveted to prevent separation
- Head Weight: 2.5 lbs.
- Face Finish: Polished
- Handle Type: Solid Steel
- Overall Length: 10-3/4"

Model No. AUW155
Mfg. No. 740191
Price/Each \$64.10



SOFT FACE DEAD BLOW HAMMER

- Steel shot filled head directs full force of blow to the work preventing rebound
- Soft face will not mar work
- Welded steel construction
- Medium hardness plastic faces are easily replaceable
- Hard and soft plastic faces available separately
- TPR handle grip for superior control and user comfort
- Head Weight: 20 oz.
- Handle Grip Type: Textured
- Handle Length: 10-1/4"
- Face: 1-3/8"

Model No. AUW119
Mfg. No. 740932
Price/Each \$67.90



BRICKLAYER'S HAMMER

- The Plumb Brick Hammer features a polished face, chamfer, bit, back and sides
- PermaBond construction between the forged head and handle securely holds the tool together
- Packaging is recyclable
- Head Weight: 24 oz.
- Face Finish: Plain
- Handle Type: Wood

Model No. UAV734
Mfg. No. CHSBK24
Price/Each \$41.50



DRILLING HAMMER

- Fibreglass handle features comfortable PVC grips
- Features rubber overstrike bumpers
- Head Weight: 3 lbs.
- Handle Type: Fibreglass
- Overall Length: 13-3/4"

Model No. UAV829
Mfg. No. 022651
Price/Each \$35.50



SUPER HEAVY-DUTY INDESTRUCTIBLE HANDLE CROSS PEIN HAMMER

- Spring steel rods encased in vulcanized rubber provide the ultimate striking tool handle
- Handle absorbs impact and vibration, reducing user fatigue
- Will not break, bend, or split even after repeated overstrikes
- Patented locking plate makes head separation impossible
- Provides unparalleled grip in all conditions and is resistant to most industrial chemicals
- Drop forged heads heat-treated to HRC 52-56
- Developed for the mining industry, these hammers are ideal for use in applications where a failure is more than just an inconvenience
- Head Weight: 3 lbs.
- Face Finish: Plain
- Handle Type: Solid Steel
- Overall Length: 16"
- Standard(s) Met: ANSI B107.400-2008
- **Manufacturer's Warranty: Lifetime Warranty**

Model No. AUW114
Mfg. No. 740179
Price/Each \$121.00



SLEDGE HAMMER

- Fibreglass handle features comfortable PVC grips
- Features rubber overstrike bumpers
- Head Weight: 4 lbs.
- Handle Type: Fibreglass
- Overall Length: 16"

Model No. UAV830
Mfg. No. 022653
Price/Each \$39.50



DEAD BLOW SLEDGE HAMMER

- Polyurethane is much tougher and longer lasting than PVC – up to 5 times the life
- Steel shot filled head directs full force of blow to the work preventing rebound
- Soft face will not mar work
- Steel skeleton encased in tough Polyurethane jacket (1 - 4 lb models)
- Fibreglass handle with Polyurethane covered striking head (6 - 12 lb models)
- TPV handle grip for superior control and comfort
- Face Finish: Rubber
- Handle Type: Solid Steel
- Temperature Range: -20°C to 90°C



AUW117

AUW118

SUPER HEAVY-DUTY INDESTRUCTIBLE HANDLE SLEDGE HAMMER

- Spring steel rods encased in vulcanized rubber provide the ultimate striking tool handle
- Handle absorbs impact and vibration, reducing user fatigue
- Will not break, bend, or split even after repeated overstrikes
- Patented locking plate makes head separation impossible
- Provides unparalleled grip in all conditions and is resistant to most industrial chemicals
- Drop forged heads heat-treated to HRC 52-58
- Developed for the mining industry, these hammers are ideal for use in applications where a failure is more than just an inconvenience
- Face Finish: Plain
- Handle Type: Solid Steel
- Standard(s) Met: ANSI B107.400-2008
- **Manufacturer's Warranty: Lifetime Warranty**



AUW115

AUW116

Model No.	Mfg. No.	Head Weight lbs.	Overall Length"	Price /Each
AUW117	740925	3	14-1/2	80.50
AUW118	740930	12	36-1/4	410.00

Model No.	Mfg. No.	Head Weight lbs.	Overall Length"	Price /Each
AUW115	740582	4	16	122.00
AUW116	740598	12	36	321.00

HAMMERS, HACKSAWS & PRY BARS



DRILLING HAMMER WITH FIBREGLASS HANDLE

- Highest fibreglass content for maximum strength
- Polymer jacketed to prevent splintering
- PVC grips for user comfort and safety
- Forged steel heads are hardened and tempered for professional use
- New improved bonding technology rated for use to -25°C
- Machined face minimizes slipping and deflection
- Head Weight: 4 lbs.
- Face Finish: Plain
- Overall Length: 10-1/2"
- Standard(s) Met: ANSI

Model No. AUW157
Mfg. No. 740953
Price/Each \$47.80



HACKSAWS

- Blade Length: 12"
- Handle Type: Plain
- Overall Dimensions: 17-5/16" L x 5-1/8" H
- Depth of Bow: 4" H
- Tensile Strength: 8000 PSI
- Strong aluminum die-cast handle provides comfort and control
- Guarded grip design protects knuckles from grazing

Model No. TYW991
Price/Each \$19.20



AURORA
TOOLS

WRECKING BAR

- High quality steel



AURORA
TOOLS

DOUBLE-FACED SLEDGE HAMMERS

- High-quality hickory handle
- Forged, new treated head
- Head secured with wood and steel wedges



Garant

Model No.	Mfg. No.	Head lbs.	Face	Length"	Price /Each
TV691	D40104	4	Polished	16	47.50
TV692	D40304	6	Polished	32	61.90
TV693	D40404	8	Polished	32	69.90
TV694	D40504	10	Polished	36	85.90
TV695	D40604	12	Polished	36	96.90

ACTION BARS

- High quality heat-treated carbon steel
- Edges are specially bevelled for pulling, lifting and scraping
- Baked paint finish



AURORA
TOOLS

Model No.	Size"	Colour	Price /Each
TJZ047	13 1/2 x 1 3/8	Black	7.85

CLUB HAMMERS

- High-quality hickory handle
- Forged, new treated head
- Head secured with wood and steel wedges



Garant

Model No.	Mfg. No.	Head lbs.	Face	Length"	Price /Each
TV688	D10004	2.5	Polished	10	37.50
TV689	D10204	4	Polished	16	43.90

GOOSENECK WRECKING BARS

- High quality steel
- Hexagon shank
- Bevelled edges for pulling and lifting



AURORA
TOOLS

Model No.	Diameter"	Length"	Weight lbs.	Price /Each
TJZ048	5/8	18	1.9	6.95
TJZ049	3/4	24	3.0	11.70
TJZ050	3/4	30	4.0	15.80
TJZ051	3/4	36	5.0	19.10

CLUB HAMMER



Model No.	Head Weight Lbs.	Overall Length"	Price /Each
TYP415	2.5	10-3/4	56.90

DOUBLE-FACED, FIBREGLASS SLEDGE HAMMERS

- High-quality fiberglass handle
- Tempered steel head for increased strength and rigidity
- Head secured with epoxy



Garant

Model No.	Mfg. No.	Head lbs.	Face	Overall Length"	Price /Each
TFX596	DF0416FG	4	Polished	19	35.90
TFX603	DF0634FG	6	Polished	39	66.90
TV697	DF0834FG	8	Polished	36	75.90
TV698	DF1034FG	10	Polished	36	85.90

EXTENDABLE PRY BARS

- Extends for greater access and leverage and collapses so you can store it securely in your tool box
- Knurled handle provides a better overall grip
- Indextible head turns 180° for greater leverage
- Grooved foot gives added traction
- Exceeds ANSI requirements for proven strength



GW GEARWRENCH

Model No.	Mfg. No.	Description	Price /Each
TLV416	82220	Overall Length 18" - 29"	128.00
TLV417	82248	29" to 48" Extendable Pry Bar	194.00

PRY BARS & PUNCHES

FLAT PRY BAR WITH GRIP

- Precision ground ends and edges allow for better access without damaging the surrounding material
- High-Viz corrosion resistant finish to protect against rust and increase durability
- 3 Beveled nail slots allow for easy prying of nails and access to nails at tough angles
- Packaging is recyclable
- Material: Alloy Steel



CRESCENT

Model No.	Mfg. No.	Width"	Overall Length"	Price /Each
UAV717	FB7-06	1-1/4	7	10.10
UAV713	FB13-06	2	13	13.80
UAV714	FB15-06	2-1/4	15	15.10

INDEXING FLAT PRY BAR

- Patented indexing head design indexes over 180 degrees and locks in 15 positions for better access and leverage
- Raised striking surface allow for use with a hammer or mallet to help loosen and penetrate nails or boards
- Dual material grip provides comfort, control and safety while applying force
- Phosphate finish helps prevent corrosion
- Precision ground ends and edges allow for better access without damaging the surrounding material
- Highly durable and heat treated forged steel is designed to maximize product life and provide ultimate durability
- Packaging is recyclable
- Material: Alloy Steel
- Finish: Powder Coated
- Tip Finish: Ground
- **Manufacturer's Warranty: Limited Lifetime**



CRESCENT

Model No.	Mfg. No.	Width"	Overall Length"	Price /Each
UAV727	DB18X-06	2-1/2	18	43.90

MINI PRY BAR

- Specifically designed to fit 10mm hex bolts for multi-purpose use
- High-Viz corrosion resistant finish to protect against rust and increase durability
- Compact size means the pry bar is easily stored in a pocket or tool pouch for easy accessibility and transportation
- Packaging is recyclable
- Material: Alloy Steel



CRESCENT

Model No.	Mfg. No.	Width"	Overall Length"	Price /Each
UAV716	FB5	3/4	5-1/4	7.50

PRY BAR SET

- Specifically designed to fit 10 mm hex bolts for multi-purpose use
- High-Viz corrosion resistant finish to protect against rust and increase durability
- Compact size means the pry bar is easily stored in a pocket or tool pouch for easy accessibility and transportation
- Packaging is recyclable
- No. of Pieces: 3
- Material: Alloy Steel

Model No. UAV715
Mfg. No. FB3PC
Price/Each \$18.80



CRESCENT

SUPER HEAVY-DUTY PINCH BARS

- Canada's premier super heavy-duty wrecking bars are designed for the toughest jobs
- Made of tough heat-treated alloy steel rather than carbon steel
- Precision ground claws are sharper and stronger than competitive products
- Electrostatic powder coated for corrosion resistance



Model No.	Mfg. No.	Material	Width"	Overall Length"	Price /Each
AUW166	779211	Alloy	0.75	18	39.00
AUW169	779232	Chrome Alloy	0.75	24	74.20
AUW170	779233	Chrome Alloy	0.87	30	90.60

MECHANIC'S PRY BAR

- Chrome Molybdenum steel for maximum strength
- Super large sizes for the heaviest duty applications
- Extra large bi-material handles provide exceptional grip and comfort and allow the use of both hands for maximum leverage
- "Go-thru" shanks with steel end caps
- Angle: 25°



Model No.	Mfg. No.	Overall Length"	Price /Each
AUW167	779221	8	20.10
AUW168	779222	12	27.60

ROLLING HEAD PRY BAR

- Chrome Molybdenum steel for maximum strength
- Super large sizes for the heaviest duty applications
- Extra large bi-material handles provide exceptional grip and comfort and allow the use of both hands for maximum leverage
- "Go-thru" shanks with steel end caps
- Rounded head acts as a fulcrum to provide extra leverage
- Tapered point and round stock ideal for aligning parts through bolt holes
- Heat treated Chrome Vanadium steel for professional use
- Magnetic particle tested to ensure complete material integrity
- Electrostatic powder coat paint protects against corrosion



Model No.	Mfg. No.	Width"	Overall Length"	Price /Each
AUW135	859214	9/16	16	58.70

ROLLING HEAD PRY BAR SET

- Chrome Molybdenum steel for maximum strength
- Super large sizes for the heaviest duty applications
- Extra large bi-material handles provide exceptional grip and comfort and allow the use of both hands for maximum leverage
- "Go-thru" shanks with steel end caps
- Rounded head acts as a fulcrum to provide extra leverage
- Tapered point and round stock ideal for aligning parts through bolt holes
- Heat treated Chrome Vanadium steel for professional use
- Magnetic particle tested to ensure complete material integrity
- Electrostatic powder coat paint protects against corrosion
- No. of Pieces: 4
- Length: 6", 12", 16", 20"

Model No. AUW134
Mfg. No. 859211
Price/Each \$185.00

JET

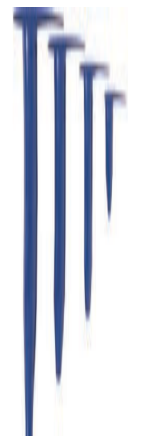

PRY BARS & PUNCHES



5-PC. PUNCH & CHISEL SET



- Heat-treated to provide a hard working end and softer striking end to avoid chipping
- High polished and lacquered working end with royal blue painted shank
- **Limited lifetime warranty**
- Meets ANSI standards
- Packaged in: Vinyl pouch
- Overall Dimensions: 7" L x 3-1/2" W x 3-1/2" H
- Weight: 1.1 lbs.

Model No. TYP518 Mfg. No. C49LR
Price/Each \$65.50



10-PC. PUNCH & CHISEL SET



- Specially heat-treated to provide a hard working end and softer striking end to avoid chipping
- High polished and lacquered working end with royal blue painted shank
- Contains: 1/2" flat chisel, 5/8" flat chisel, 3/4" flat chisel, 3/32" taper punch, 5/32" taper punch, 3/16" taper punch, 5/32" pin punch, 3/32" pin punch, 3/16" pin punch, 3/8" centre punch

Model No. QP097 Mfg. No. C10LRA
Price/Each \$139.00



PILOT PUNCHES

- Heat-treated to provide a hard working end and softer striking end to avoid chipping
- High polished and lacquered working end with royal blue painted shank
- Limited lifetime warranty
- Meets ANSI standards



Model No.	Mfg. No.	Width"	Point Diameter"	Stock Size"	Body"	Overall Length"	Wt. lbs.	Price /Each
TYP538	C500	1/4	1/16	3/16	3/16	2 3/4	0.02	12.90
TYP539	C501	1/4	5/64	3/16	3/16	3 1/4	0.02	13.50
TYP540	C502	1/4	3/32	3/16	3/16	3 1/2	0.03	14.50
TYP541	C503	1/4	1/8	1/4	1/4	4	0.03	14.90
TYP542	C504	1/4	5/32	1/4	1/4	4 1/2	0.04	16.90
TYP543	C505	1/4	3/16	3/8	3/8	4 1/2	0.08	17.50
TYP544	C506	1/4	7/32	3/8	3/8	5	0.09	19.50
TYP545	C507	1/4	1/4	7/16	7/16	5 1/2	0.17	21.90
TYP546	C508	1/2	5/16	7/16	7/16	6	0.2	24.50
TYP547	C509	1/2	3/8	1/2	1/2	6	0.3	24.90
TYP548	C510	3/4	7/16	5/8	5/8	6	0.3	29.50
TYP549	C511	3/4	1/2	5/8	5/8	6	0.4	33.50

BRASS DRIFT PUNCH

- Knurled body provides superior grip and hold
- Ideal for use in non-marring applications
- **Limited lifetime warranty**
- Meets ANSI standards



Model No.	Mfg. No.	Width"	Point Diameter"	Stock Size"	Body"	Overall Length"	Wt. lbs.	Price /Each
TYP551	CBR6	1/2	3/8	3/8	3/8	6	0.3	21.50
TYP552	CBR7	1/2	1/2	1/2	1/2	7	0.4	27.90
TYP553	CBR8	3/4	3/4	3/4	3/4	8	1.1	56.50

5-PC. BRASS PUNCH SET



- Contains: Brass Taper Punch 1/4", Brass Pin Punch 3/8" and Brass Drift Punches 3/8", 1/2" & 3/4"
- Packaged in: Vinyl pouch
- Overall Dimensions: 8-1/4" L x 4" W x 1" H
- Weight: 2 lbs.
- Knurled body provides superior grip and hold
- Ideal for use in non-marring applications
- **Limited lifetime warranty**
- Meets ANSI standards

Model No. TYP555 Mfg. No. C5BDS
Price/Each \$149.00



14-PC. PUNCH & CHISEL SET

- Heat-treated to provide a hard working end and softer striking end to avoid chipping
- High polished and lacquered working end with royal blue painted shank
- **Limited lifetime warranty**
- Meets ANSI standards
- Contains: Flat Chisels 1/2", 5/8", 3/4", 7/8", Cape Chisel 1/4", Long Taper Punches 5/32", 3/16", Taper Punches 3/32", 1/8", 3/16", Pin Punches 1/8", 3/32", 3/16" and Centre Punch 3/8"
- Overall Dimensions: 12" L x 10-1/2" W x 1" H
- Weight: 5.95 lbs.

Model No. TYP512 Mfg. No. C14LR
Price/Each \$269.00



CENTRE PUNCHES

- Single piece construction with hexagonal shank increases durability
- Manufactured from high quality carbon steel
- Accurately hardened for increased service life
- Bevelled striking end to prevent breakage
- The working tips are centred and ground to 90° for increased marking efficiency

5-PC. CENTRE PUNCH SET

Set includes sizes: 5/64", 1/8", 5/32", 1/4", and 3/8"

Model No. TLZ423
Price/Each \$35.95



AURORA
TOOLS

Model No.	Point Diameter"	Stock Size"	Length"	Price /Each
TLZ415	5/64	1/4	3 1/2	5.10
TLZ416	1/8	5/16	4 1/4	5.55
TLZ417	5/32	3/8	5	5.55
TLZ418	1/4	1/2	6	7.20
TLZ419	3/8	5/8	6 1/4	9.50

PIN PUNCHES

- Ideal for driving out and removing already loosened pins and keys after initial movement by a starting punch
- Manufactured from high quality carbon steel
- Single piece construction with hexagonal shank increases durability
- Accurately hardened for increased service life

7-PC. PIN PUNCH SET

Set includes sizes: 1/16", 3/32", 1/8", 5/32", 3/16", 7/32", and 1/4"

Model No. TLZ421
Price/Each \$36.75



AURORA
TOOLS

Model No.	Point Diameter"	Stock Size"	Length"	Price /Each
TLZ401	1/16	1/4	4	4.65
TLZ402	3/32	5/16	4 1/2	5.40
TLZ403	1/8	5/16	4 3/4	5.60
TLZ404	5/32	5/16	5	5.60
TLZ405	3/16	5/16	5 1/4	5.60
TLZ555	7/32	3/8	5 1/2	5.90
TLZ406	1/4	3/8	5 3/4	6.50
TLZ407	5/16	7/16	6	8.70

PRY BARS & PUNCHES

DRIFT PUNCHES

- Ideal for lining up holes in two or more pieces of metal and for drawing pins through various assemblies
- Manufactured from high quality carbon steel
- Single piece construction with hexagonal shank increases durability
- Accurately hardened for increased service life

7-PC. DRIFT PUNCH SET

Set includes sizes:
1/8", 5/32", 3/16", 7/32", 1/4", 5/16", and 3/8"

Model No. TLZ422
Price/Each \$110.00

AURORA
TOOLS



Model No.	Point Size"	Stock Size"	Length"	Price /Each
TLZ408	1/8	5/16	8	7.80
TLZ409	5/32	3/8	9	8.65
TLZ410	3/16	1/2	10	11.60
TLZ411	7/32	1/2	10	13.00
TLZ412	1/4	5/8	12	15.70
TLZ413	5/16	3/4	12	19.35
TLZ414	3/8	3/4	15	23.95

LONG PIN PUNCHES

- Heat-treated to provide a hard working end and softer striking end to avoid chipping
- High polished and lacquered working end with royal blue painted shank
- **Limited lifetime warranty**
- Meets ANSI standards

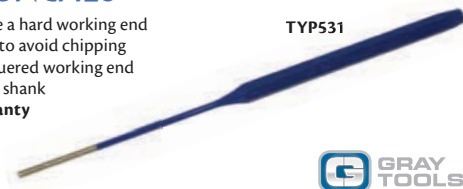

GRAY TOOLS

Model No.	Mfg. No.	Width"	Point Diameter"	Stock Size"	Body"	Overall Length"	Wt. lbs.	Price /Each
TYP531	C290	1/4	1/8	5/16	5/16	8	0.11	17.50
TYP532	C291	1/4	5/32	5/16	5/16	8	0.12	18.50
TYP533	C292	1/4	3/16	3/8	3/8	8	0.2	18.90
TYP534	C293	1/4	7/32	3/8	3/8	8	0.2	21.50
TYP535	C294	1/4	1/4	3/8	3/8	8	0.2	22.50
TYP536	C295	1/2	5/16	7/16	7/16	8	0.3	24.50
TYP537	C296	1/2	3/8	1/2	1/2	8	0.4	26.50

BRASS PIN PUNCH

- Knurled body provides superior grip and hold
- Ideal for use in non-marring applications
- **Limited lifetime warranty**
- Meets ANSI standards



GRAY TOOLS

Model No.	Mfg. No.	Width"	Point Diameter"	Stock Size"	Body"	Overall Length"	Wt. lbs.	Price /Each
TYP550	CB30	1/2	3/8	3/4	1/2	6	0.3	26.50

BRASS TAPER PUNCH

- Knurled body provides superior grip and hold
- Ideal for use in non-marring applications
- **Limited lifetime warranty**
- Meets ANSI standards



GRAY TOOLS

Model No.	Mfg. No.	Width"	Point Diameter"	Body"	Taper Length"	Overall Length"	Wt. lbs.	Price /Each
TYP578	CB27	1/2	1/4	1/2	2	6	0.3	25.90

PUNCH & CHISEL SETS

- Punch and chisel sets are an excellent way to keep your tools organized
- These sets are packed in heavy-duty vinyl rolls for easy access, organization and storage

8-PC. PUNCH & CHISEL SET:

Model No. TLZ433
Price/Each \$62.35

AURORA
TOOLS



Set includes:

Model No.	Style	Size"	Price /Each
TLZ398	Cold Chisel	1/2	8.45
TLZ399	Cold Chisel	5/8	9.15
TLZ400	Cold Chisel	3/4	15.10
TLZ417	Centre Punch	5/32	5.55
TLZ403	Pin Punch	1/8	5.60
TLZ405	Pin Punch	3/16	5.60
TLZ406	Pin Punch	1/4	6.50
TLZ410	Drift Punch	3/16	11.60

14-PC. PUNCH & CHISEL SET:

Model No. TLZ434
Price/Each \$105.00

AURORA
TOOLS



Set includes:

Model No.	Style	Size"	Price /Each
TLZ397	Cold Chisel	3/8	8.45
TLZ398	Cold Chisel	1/2	8.45
TLZ399	Cold Chisel	5/8	9.15
TLZ400	Cold Chisel	3/4	15.10
TLZ556	Cold Chisel	7/8	18.30
TLZ416	Centre Punch	1/8	5.55
TLZ417	Centre Punch	5/32	5.55
TLZ418	Centre Punch	1/4	7.20
TLZ401	Pin Punch	1/16	4.65
TLZ403	Pin Punch	1/8	5.60
TLZ405	Pin Punch	3/16	5.60
TLZ408	Drift Punch	1/8	7.80
TLZ409	Drift Punch	5/32	8.65
TLZ413	Drift Punch	5/16	19.35

SCRIBER WITH MAGNET

- The scriber is the perfect tool for making sharp accurate lines on hardened materials
- End cap magnet picks up stray metal shavings
- Works easily on metal, plastic, ceramics, glass and more
- Equipped with a convenient pocket-clip and cap
- Overall Length: 5"
- Tip Material: Tungsten Carbide

Model No. UAK142
Price/Each \$9.95

AURORA
TOOLS



PRY BARS, PUNCHES & CAULKING GUNS



COLD CHISELS

- Individually forged from high quality alloy steel
- Manufactured to the highest safety standards
- Precisely ground cutting edge is induction hardened to 52-58 HRC
- Striking head is hardened to 42 HRC to prevent splintering during use

6-PC. COLD CHISEL SET

Set includes sizes: 1/4", 5/16", 3/8", 1/2", 5/8", and 3/4"

Model No. TLZ420
Price/Each \$44.25



Model No.	Width of Cut"	Stock Size"	Overall Length"	Price /Each
TLZ395	1/4	1/4	5	5.15
TLZ396	5/16	1/4	5	6.15
TLZ397	3/8	5/16	5 1/2	8.45
TLZ398	1/2	7/16	6	8.45
TLZ399	5/8	1/2	6 1/2	9.15
TLZ400	3/4	5/8	7	15.10
TLZ556	7/8	3/4	7 1/2	18.30

ROLL PIN PUNCH SET

- Made of the highest grade carbon steel, accurately hardened and tempered preventing splintering and extending life
- Powder coated shank protects against rust
- Edges accurately tempered to stay sharp
- Extra-thick hexagonal shanks minimize roll away
- Working ends accurately ground and hardened to HRC 52-58 for maximum service
- Striking end hardened to HRC-42 maximum – won't chip or mushroom
- No. of Pieces: 6
- **Includes:** 3/32", 1/8", 5/32", 3/16", 1/4", 5/16"
- Standard(s) Met: CDA39GP-43a

Model No. AUW124
Mfg. No. 775526
Price/Each \$65.60



COLD CHISEL WITH GRIP GUARD

- Individually forged from high quality alloy steel
- Manufactured to the highest safety standards
- Precisely ground cutting edge is induction hardened to 52-58 HRC
- Striking head is hardened to 42 HRC to prevent splintering during use



Model No.	Width of Cut"	Stock Size"	Overall Length"	Price /Each
TYB509	3/4	5/8	10	22.85
TYB510	3/4	5/8	12	24.95
TYB511	1	7/8	10	29.95
TYB512	1	7/8	12	32.60

RATCHET STYLE CAULKING GUN

- Equipped with built-in spout cutter, seal-puncture tool and ladder hook
- Compact size to fit in a tool box
- Comfortable operation
- Smooth application
- Cartridge Capacity: 300 ml

Model No. UAE002
Price/Each \$10.80



CAULKING GUN

- Compact size to fit in a tool box
- Skeleton design
- Comfortable operation
- Smooth hexagonal drive rod
- Seal-puncture tool
- Steady release
- Smooth application
- Ladder Hook
- Cartridge Capacity: 300 ml

Model No. TYY156
Price/Each \$8.35



Maintain the ideal temperature in your workplace



MAGNETIC PARTS RETRIEVERS

Remove steel parts from bins, boxes, kegs, tables or floors.

- Durable aluminum housing with comfortable non-slip handle
- Powerful, lightweight permanent magnet
- Easy release of collected parts or scrap



MAG-MATE

SHORT HANDLED VERSION

Model No.	Holding Capacity lbs.	L"	W"	H"	Price /Each
TGY633	7	4 1/2	2 3/8	7 1/2	170.00
TGY635	11	4 1/2	2 3/8	7 1/2	220.00

MAGNETIC TRIGGER LIFTS

Hand held lift provides a strong grip on parts with an easy to use trigger release.

- Lightweight aluminum housing
- One hand operation
- Move sheets and parts fast, safely and easily
- Retrieve hot parts from burn tables



MAG-MATE

BURN TABLE/PARTS HANDLING

Model No.	Holding Capacity lbs.	L"	W"	H"	Price /Each
TGY637	55	3 3/8	2 3/8	4 13/16	225.00

HOSE CORD HOOK/HOLDER MAGNET

- Sturdy stainless steel holder
- Plated permanent ceramic cup magnet
- Secure hoses, cables, cords and more to any flat surface
- Holds up to 45 lbs.
- Width: 73 mm
- Length: 111 mm

Model No. TYX074
Mfg. No. MX2750HC1
Price/Each \$28.20



MAG-MATE

ON/OFF MAGNETIC HANGING HOOKS

- Hanging hooks are perfect for temporary holding of lines, hoses, lights, tools and more
- Powerful rare earth magnet
- Locking On/Off handle
- Attaches to flat or round surface with ease



Model No.	Strength lbs.	Diameter"	Length"	Height"	Weight lbs.	Price /Each
TY0548	35	1 3/4	5 3/4	2 3/4	0.95	161.00
TY0549	110	2 1/2	7 5/8	4 5/8	4.65	382.00

POWER GRIPS

- Holds against shear force
- Securely grips heavy parts
- Aluminum insulated
- Epoxy encapsulated magnet



MAG-MATE

Model No.	Length"	Height"	Width"	Holding Value lbs.	Price /Each
LS717	2 1/8	2	3/4	25	74.00
LS718	4	2 1/4	3/4	51.5	81.10
LS719	5 1/4	2 3/4	1 7/8	92.5	102.00

MAG-MAID MAGNETIC CLEAN-UP TOOLS

- Picks up steel chips, fasteners and scrap from swarf
- To clean, simply pull the plunger handle to the top of the tube and the collected metal falls off
- Powerful rare earth magnet



MAG-MATE

Model No.	Length"	Diameter"	Wt. lbs.	Price /Each
TGY638	15	1	1.25	113.00
TGY639	36	1	2.75	179.00

MAGNETIC PRINT HOLDERS

- Ideal for holding papers, prints and charts against steel partitions, machinery and metal desks
- Magnetic strength holds through many layers of paper
- Does not mark or tear paper



MAG-MATE

Model No.	Pull lbs.	Dia."	Height"	Price /Each
TGY600	7	1 13/64	11/16	6.02
TGY601	12	1 13/32	9/32	6.85
TGY602	19	2 1/32	5/16	7.82

LONG REACH MAGNETIC RETRIEVERS

- Powerful pickup tools
- Durable handle with grip
- Model TGY621 has a 45° angled head



MAG-MATE

Model No.	Handle Length"	Head Dimensions	Holding Capacity lbs.	Price /Each
TGY621	38	3 1/4" Dia.	47.5	37.60
TGY622	39.72	6" x 1 3/8"	28	177.00

MAGNETS

MAGNETIC STRIPS

- Conforms to any contour
- Holds many times its weight
- Can be cut, drilled or shaped
- Available with or without adhesive backing



MAG-MATE™

Thick"	Width"	Length'	Max. Pull per Lin. Ft. (lbs.)	Model No. w/o Adhesive	Price /Roll	Model No. w/Adhesive	Price /Roll
1/32	1/2	200	2	TGY640	61.20	TGY648	116.00
1/32	3/4	200	3	-	-	TGY649	148.00
1/32	1	100	4	TGY642	57.00	TGY650	94.10
1/32	1	200	4	TGY643	95.80	TGY651	165.00
1/16	1/2	100	3	TGY644	50.30	TGY652	86.80
1/16	3/4	100	5	TGY645	65.00	TGY653	102.00
1/16	1	50	6	TGY646	47.70	TGY654	73.00
1/16	1	100	6	TGY647	91.50	TGY655	134.00

VERTICAL LUG ADAPTER FOR RARE EARTH ADVANTAGE LIFT™ MAGNETS

- Adapter for "on/off" permanent rare earth lift magnet
- Locking lifting bail(s) prevents accidental load release during lift
- Lifts flats both horizontally and vertically with Vertical Lift Bail
- 3:1 design factor
- ASME B30.20 BTH-1 Design Category B Service Class 3
- For Use With: AL0500 & AL1000 Magnets
- Operating Temperature Range: -10°F (-23°C) to 180°F (82 °C)

UAV702



MAG-MATE™

Model No.	Mfg. No.	Dimensions L" x W" x H"	Bail Thickness"	Bail Height"	Bail Width"	Price /Each
UAV701	ALLUG1	4-11/16 x 4-3/8 x 3-9/16	1/2	1-7/8	1-1/2	157.00
UAV702	ALLUG2	5-3/4 x 5-3/4 x 4-3/4	5/8	2-7/32	1-3/4	166.00

ADVANTAGELIFT™ RARE EARTH LIFTING MAGNET

MAG-MATE™

- Handle moves laterally instead of pulling, pressing buttons or levers
- Locking lifting bail(s) prevents accidental load release during lift
- Recessed (protected) labels for extended life
- Lifts flats both horizontally and vertically with Vertical Lift Bail
- RFID Enabled with embedded RFID chip
- Supports custom pole shoes (1/4"-20 Tapped Holes, 1/2" deep)
- Swiveling Lift Bail(s)
- Operating temperature range of -10°F (-23°C) to 180°F (82 °C)
- 3:1 Design Factor
- ASME B30.20 BTH-1 Design Category B Service Class 3



Model No.	Mfg. No.	Strength lbs.	Dimensions L" x W" x H"	Price /Each
UAV698	AL1000	1000	13-1/4 x 5-7/16 x 4-5/8	1112.00
UAV699	AL1500	1500	13-5/16 x 6-7/8 x 6	1715.00
UAV700	AL2000	2000	16-5/16 x 6-7/8 x 6	2169.00

MAGNETIC TOOL HOLDERS

- Mount to walls, work benches, ladders, etc.
- 3/16" mounting holes and screws provided
- TLY308 and TLY309: holes on 16" centres
- Holds a 10-lb. hammer!

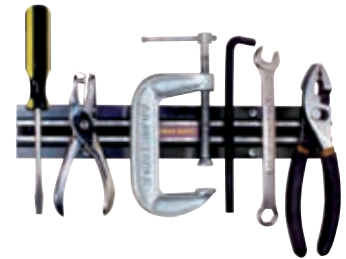

MAG-MATE™

Model No.	Thickness"	H"	L"	Pull lbs.	Wt. lbs.	Price /Each
TLY307	1 1/8	2	12	120	2.0	55.40
TLY308	1 1/8	2	18	180	3.0	63.70
TLY309	1 1/8	2	24	240	4.0	73.40

TELESCOPIC MAGNETIC RETRIEVERS

- Ideal for reaching behind, underneath or around machinery and/or difficult to reach areas
- Rare earth magnet material
- Max. temperature of 180° F (82° C)

MAG-MATE™

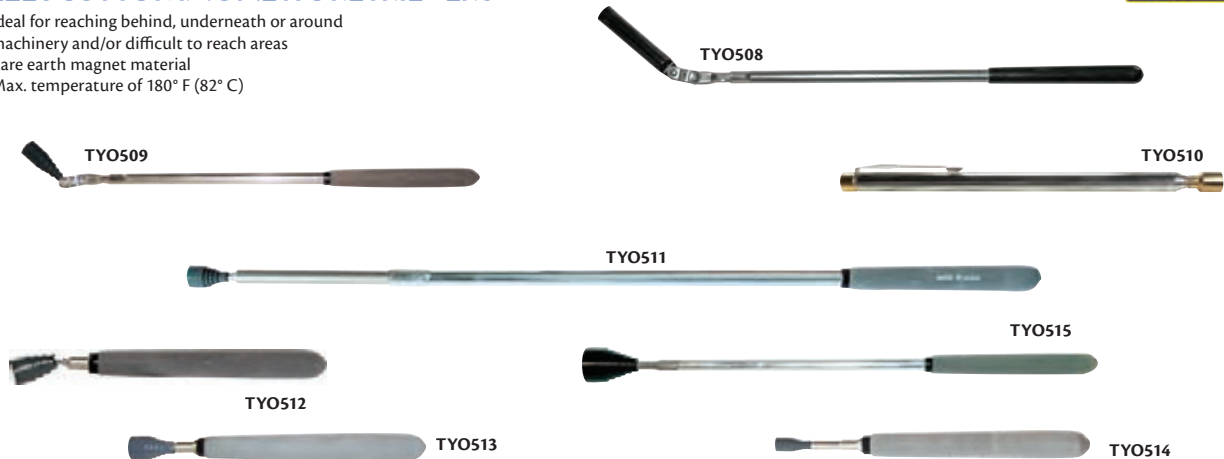

Model No.	Mfg. No.	Strength lbs.	Diameter"	Length"	Extended Length"	Weight lbs.	Price /Each
TYO508	927	7.5	1/2	17	26 1/2	0.36	28.50
TYO509	931	12	1/2	13	26	0.44	41.60
TYO510	240N	2	5/16	5 1/2	25 1/2	0.07	8.53
TYO511	926	14	5/8	23 1/2	50	0.42	58.10
TYO512	925	7	5/8	8	35	0.19	39.30
TYO513	923	5	3/8	6 1/2	32	0.14	24.20
TYO514	924	7	5/8	6 1/2	32	0.18	36.90
TYO515	990SM	20	1 1/8	16 1/2	29	0.65	82.50

MEASURES, RULES, SQUARES & LEVELS



SHOCKFORCE™ G1 DUAL SIDED TAPE MEASURE

- Matte nylon-coated blade provides extended product life and glare reduction
- Narrow blade technology offers reduced weight when carrying a tape all day on the job site
- Optimized drum and spring design provides a compact case that fits comfortably in the palm of your hand
- Drop tested from 100 feet for real life, on the job durability
- Dual-sided blade printed with vertical quick read scale on underside for overhead and hard-to-reach measurements
- Steel tether point offers increased safety capability when working at height
- Tether point can also be used for scribing and drawing arcs during layout
- Packaging is recyclable
- **Manufacturer's Warranty: Limited Lifetime**



UAV732



Model No.	Mfg. No.	Blade Width"	Blade Length	Graduations	Price /Each
UAV732	L1116CME-02	1-3/16	16', 5 m	Imperial & Metric	25.10
UAV673	L1125-02	1-3/16	25'	Imperial	31.30
UAV729	L1135-02	1-3/16	35'	Imperial	40.10

SHOCKFORCE™ NITE EYE DUAL SIDED TAPE MEASURE

- Made for superior legibility in any light condition, Shockforce™ Nite Eye Dual Sided Tape Measure features a high visibility green-on-matte black blade
- Diamond-coated end hook grabs material from every direction and prevents slippage
- Matte nylon blade provides extended product life and glare reduction
- Optimized drum and spring design provides a compact case design that fits comfortably in the palm of your hand
- Dual-sided blade print with vertical quick read scale on underside for overhead and hard to reach measurements
- Steel tether point offers increased safety capability when working at height and can also be used for scribing and drawing arcs during layout
- Narrow blade technology offers reduced weight
- Blade Colour: Black
- Font Colour: High Visibility Green



UAV730



Model No.	Mfg. No.	Blade Width"	Blade Length	Graduations	Price /Each
UAV730	L1116B-02	1-3/16	16'	Imperial	25.10
UAV731	L1135B-02	1-3/16	35'	Imperial	40.10

AUTOLOCK MEASURING TAPES

- High visibility with rubber comfort grip
- Automatic blade lock
- Recessed lock release
- **TLZ075** comes with magnetic end hook



TJZ389



Model No.	Mfg. No.	Blade Width"	Length	Graduations	Stud Markings"	Price /Each
TJZ389	AL725	1	25'	in/ft.	16/19.2	18.80
TJZ388	AL748CME	1	26/8 m	in/cm	16/19.2	18.80

HI-VIZ® ORANGE MEASURING TAPES

- Hi-Viz® orange case - easy to find on the job
- Rubber cushion case exterior protects tape from impact and improves grip
- Fits easily into most tape holsters
- Bright yellow blade has clear easy-to-read numerals
- Toggle lock is positioned for convenient operation
- Holds the blade securely in any position
- Cushioned blade return
- Removable belt clip



TLV589



Model No.	Mfg. No.	Blade Width"	Length	Graduations	Stud Markings"	Price /Each
TLV596	PHV1312	3/4	12'	in/ft.	16	16.30
TLV605	PHV1316	3/4	16'	in/ft.	16	18.80
TLV612	PHV1425	1	25'	in/ft.	16/19.2	25.10
TLV620	PHV1433	1	33'	in/ft.	16/19.2	28.80
TLV604	PHV1035CME	3/4	16/5 m	in/cm	-	18.80
TLV610	PHV1048CME	1	26/8 m	in/cm	19.2	25.10
TLV619	PHV1410CME	1	33/10 m	in/cm	19.2	28.80

700 SERIES MAGNETIC END HOOK MEASURING TAPES

- Magnetic end hook is a time-saver for framers, HVAC installers and more
- Use for one-man measurements of steel framing and drop ceiling grids
- Powerful dual magnets can also serve as a pick-up tool
- Non-slip co-molded rubber grip
- Durable clear coat blade protection for longer blade life
- Steel reinforced end hook for longer service life
- Tough ABS case to stand up to the toughest work site



Model No.	Mfg. No.	Blade Width"	Length	Graduations	Stud Markings"	Price /Each
TLZ169	L725MAG	1	25'	in/ft.	16/19.2	22.60

KTXP SERIES MEASURING TAPES

- Silver-grey high impact resistant PC-ABS plastic for superior case life
- Positive sliding lock holds tape securely while transferring measurement to work surface
- Blade Colour: Yellow
- Protective nylon coating provides 2X blade abrasion resistance, protecting numbers and graduations
- End type: Self adjusting end hook
- Includes a black anodized steel belt clip



TLV542



Model No.	Mfg. No.	Blade Width"	Length	Graduation Style	Graduations	Price /Each
TLV542	KTXP106-25-N	1	25'	English	1/16"	38.90
TLV543	KTXP106-26ME-N	1	26/8 m	English/Metric	1/16" and Millimeters	39.90
TLV545	KTXP106-35-N	1	35'	English	1/16"	52.50
TLV541	KTXP106-16-N	1	16'	English	1/16"	27.50
TLV540	KTXP106-16ME-N	1	16/5 m	English/Metric	1/16" and Millimeters	27.50
TLV544	KTXP106-30-N	1	30'	English	1/16"	47.50

MEASURES, RULES, SQUARES & LEVELS

KTX SERIES MEASURING TAPES

- Red ABS plastic and ergonomic design provides durability and comfort
- Positive sliding lock holds tape securely while transferring measurement to work surfaces
- Blade Colour: Yellow
- Protective nylon coating provides 2X blade abrasion resistance, protecting numbers and graduations
- End type: Self adjusting end hook
- Includes a steel belt clip



Starrett®

Model No.	Mfg. No.	Blade Width"	Length	Graduation Style	Graduations	Price /Each
TLV538	KTX34-16-N	3/4	16'	English	1/16"	16.50
TLV537	KTX34-16ME-N	3/4	16'	English/Metric	1/16" and Millimeters	15.50
TLV539	KTX34-5M-N	3/4	5 m	Metric	Millimeters	15.50
TLV530	KTX12-12-N	1/2	12'	English	1/16"	11.50
TLV529	KTX12-12ME-N	1/2	12'	English/Metric	1/16" and Millimeters	10.90
TLV531	KTX12-3.5M-N	1/2	3.5 m	Metric	Millimeters	10.90
TLV532	KTX1-25-N	1	25'	English	1/16"	26.50
TLV533	KTX1-26ME-N	1	26'	English/Metric	1/16" and Millimeters	27.90
TLV534	KTX1-30-N	1	30'	English	1/16"	30.90
TLV535	KTX1-35-N	1	35'	English	1/16"	36.90
TLV536	KTX1-8M-N	1	8 m	Metric	Millimeters	27.50

MEASURING TAPES

- Heavy-duty tape line
- Sure locking break
- Easy-to-read blade
- Two rivets holding the tip for extra security
- Composite covering for extra comfort



AURORA TOOLS

Model No.	Blade Width"	Length'	Graduations	Price /Each
TJZ803	1	30	in/ft.	14.30

TAPE MEASURES

- Co-extruded blue and black case with anti-slip grip
- High performance blade with nylon coating



AURORA TOOLS

Model No.	Blade Width"	Blade Length'	Graduations	Locking Mechanism	Price /Each
UAV722	5/8	12	Imperial & Metric	Toggle	5.45
UAV723	1	16	Imperial	Press Button	7.45
UAV724	1	16	Imperial & Metric	Press Button	7.45
UAV725	1	25	Imperial & Metric	Press Button	11.25

TAPE MEASURE

- Impact-resistant case is made with an ergonomic-style rubber jacket for maximum comfort and easy grip
 - Durable nylon-coated blade is resistant to corrosion and breakage
 - High-contrast/high-viz markings are easy to read even in low-lit working conditions
 - Strong magnetic hook attaches to objects such as steel studs and conduit to allow easy one-hand measuring
 - Built-in bumper cushion absorbs recoil impact and reduces tape breakage
 - Stud and joist locaters conveniently marked at every 16" and 19.2"
 - Blade Length: 25'
 - Graduations: Imperial & Metric
 - Material: Steel, ABS
- Model No. AUW125**
Mfg. No. 775924
Price/Each \$23.20



JET

WIDE BLADE TAPE MEASURE

- Anti-tear coating reinforces the first 6" of the tape blade
 - Impact-resistant 5-point reinforced frame
 - Finger stop delivers tape retraction control
 - 2-sided printing for easy reading
 - Architectural scale
 - Wire form belt clip
 - Lanyard-ready for quick and easy tethering
- Tool Warranty: Limited Lifetime**



Milwaukee

Model No.	Mfg. No.	Blade Width"	Length'	Graduation Style	Price /Each
TYX869	48-22-0216	1-1/4	16'	Imperial	29.90
TYX871	48-22-0217	1-1/4	16'5 m	Imperial/Metric	29.90
UAJ686	48-22-0225	1-5/16	25'	Imperial	33.50
UAJ543	48-22-0226	1-5/16	26'8m	Imperial/Metric	33.50

STUD™ TAPE MEASURE

- Equipped with innovative EXO360™ Blade Technology
 - EXO360™ protects your tape's blade from ripping and wearing
 - Features double-sided printing for easy reading as well as a finger stop to control blade retraction.
 - Fully reinforced impact-resistant frame can survive an 80' drop
 - Blade is wrapped in a high density nylon coating
 - Blade resists tearing from repetitive bending and fast blade retraction
 - Blade resists wear, delivering numbers and markings that last 10X longer
 - Lanyard-ready for quick and easy tethering
 - Anti-tear coating reinforces the first 6" of the tape blade
- Limited Lifetime Warranty**

Milwaukee



Model No.	Mfg. No.	Blade Width"	Length'	Graduation Style	Price /Each
AUW184	48-22-9716	1-5/16	16	Imperial	33.50
AUW185	48-22-9725	1-5/16	25	Imperial	34.90
AUW187	48-22-9735	1-5/16	35	Imperial	56.90
MAGNETIC					
AUW186	48-22-9725M	1-5/16	25	Imperial	39.90

MEASURES, RULES, SQUARES & LEVELS



COMPACT TAPE MEASURE

- Anti-tear coating reinforces the first 6" of the tape blade
- Nylon blade protection reduces tape tear
- Impact-resistant 5-point reinforced frame
- Finger stop delivers tape retraction control
- 2-sided printing for easy reading
- Architectural scale
- Wire form belt clip reduces pocket tearing
- Lanyard-ready for quick and easy tethering
- Blade Colour: Yellow



UAI593

Model No.	Mfg. No.	Blade Width"	Length	Graduation Style	Price /Each
UAK199	48-22-6612	25 mm	12'	Imperial	14.50
UAK200	48-22-6616	25 mm	16'	Imperial	17.50
UAK201	48-22-6617	25 mm	16', 5 m	Imperial & Metric	17.50
UAF944	48-22-6625	1"	25'	Imperial	23.50
UAK202	48-22-6626	25 mm	26', 8 m	Imperial & Metric	23.50

MAGNETIC*

UAK198	48-22-0335	1	35'	Imperial	34.90
--------	------------	---	-----	----------	-------

* Magnet holds to EMT and steel studs

STEEL TAPE MEASURE

- 0-point inside ring provides increased measuring accuracy
- Unique fold-away handle delivers unsurpassed rewind speed
- High contrast/high-vis markings are easy to read even in low lit working conditions
- Blade Length: 100'
- Blade Width: 1/2"
- Graduations: Imperial & Metric
- Standard(s) Met: MID III (Measuring Instruments Directive)

Model No. AUW126
Mfg. No. 775937
Price/Each \$35.50



SPEEDWINDER® HIGH VISIBILITY TAPE MEASURE

- Impact-resistant, attractive, self-standing case
- Heavy-duty yellow clad blade
- Extends, rewinds in less time than conventional long steel tapes
- Easy-to-read bold black markings
- Colour: High-Visibility Orange
- Blade Material: Steel
- Rewind Type: Manual



TBG613



Model No.	Mfg. No.	Blade Width"	Length'	Graduation Style	Price /Each
TBG613	HYT100	3/8	100	Imperial	53.60
TBG615	HYT50	3/8	50	Imperial	46.90

POWERLOCK® TAPE MEASURE

- Mylar® polyester film extends life of entire blade
- Chrome high-impact ABS case is job site tough
- Secure blade lock won't creep during measurements
- 16" and 19.2" stud centre markings simplify framing jobs
- Corrosion-resistant Tru-Zero® hook for accurate inside/outside measurements
- Body Finish: Chrome
- Blade Coating: Mylar®



TK987

STANLEY

Model No.	Mfg. No.	Blade Width"	Length	Graduation Style	Stud Marks	Price /Each
TK995	33-212	1/2	12'	Imperial	16" & 19.2"	17.90
TK997	33-272	1/2	12'	Imperial	-	23.50
UAD797	33-215	1/2	3.5 m	Imperial/Metric	16" & 19.2"	17.90
TK999	33-312	3/4	12'	Imperial	16" & 19.2"	21.90
TK987	33-116	3/4	16'	Imperial	16" & 19.2"	17.90
TL006	33-430	1	30'	Imperial	16" & 19.2"	30.90

CLOSED REEL LONG TAPE

- Features classic vinyl-clad steel case
- Manufactured with nylon rollers at case opening to reduce blade wear
- Easy-to-read graduations
- Includes a folding hook ring
- Model TBE219: One side is in inch diameter measurements with 100th Vernier scale, while the other side is graduated in 1/8" and numbered in consecutive inches to each foot
- Colour: Black
- Blade Material: Steel
- Blade Coating: Polyurethane Over Baked Enamel



TBE215



Model No.	Mfg. No.	Blade Width"	Length	Graduation Style	Price /Each
TBE215	65949	3/8	50'	Imperial	72.50
TBE219	65953	3/8	50'	Imperial	72.50
TBE222	65956	3/8	15 m	Metric	64.50



TOOLS THAT MEASURE UP!

AURORA TOOLS

MEASURES, RULES, SQUARES & LEVELS

CLOSED REEL LONG TAPE

- Features impact resistant ABS plastic case
- Easy-to-read graduations
- Includes a folding hook ring
- Colour: Yellow
- Blade Material: Steel
- Blade Coating: Polyurethane Over Baked Enamel

TLV517



Starrett®

Model No.	Mfg. No.	Blade Width"	Length	Graduation Style	Price /Each
TLV520	KTS510-50-N	3/8	50'	Imperial	20.90
TLV519	KTS510-50ME-N	3/8	15 m, 50'	Imperial/Metric	20.90
TLV518	KTS510-100-N	3/8	100'	Imperial	33.50
TLV517	KTS510-100ME-N	3/8	100', 30 m	Imperial/Metric	32.90

FIBREGLASS MEASURING TAPES

- High-visibility, high-impact case
- Easy-to-read blade
- English marking on one side, metric on the other
- Fast-rewind blade return



CRESCENT Lufkin

Model No.	Mfg. No.	Blade Width"	Length	Graduations	Price /Each
TY327	FM030CME	1/2	100/30 m	in/ft. - m/cm	31.30
TY328	FM050CME	1/2	164/50 m	in/ft. - m/cm	35.10
TY329	FM100CME	1/2	328/100 m	in/ft. - m/cm	56.40

PRO SERIES NY-CLAD® STEEL MEASURING TAPES

- High-visibility, high-impact orange case
- Easy-to-read blade
- Steel tape (nominal thickness 0.022") is nylon clad for long life
- Fast-rewind blade return



CRESCENT Lufkin

Model No.	Mfg. No.	Blade Width"	Length'	Graduations	Price /Each
TJ789	PS1806N	1/2	100	in/ft. (1/8)	84.00
TJ790	PS1806DN	1/2	100	in/ft. (1/10-1/100)	84.00
TJ791	PS1808N	1/2	200	in/ft. (1/8)	132.00
TJ792	PS1808DN	1/2	200	in/ft. (1/10-1/100)	132.00

EXTRA-WIDE FIBREGLASS LONG MEASURING TAPES

- Ring end hook snaps onto stake for 1-person measurements
- Standard folding end hook for general measuring needs
- 3-to-1 rewind for fast blade retraction
- 3/4" 2-sided blade is more durable; large numbers are easy to read
- Fibreglass strands and double-PVC coating for durability and strength
- Cushion grips on handle and frame arms for comfort
- Includes three interchangeable end attachments



CRESCENT Lufkin

Model No.	Mfg. No.	Blade Width"	Length	Graduations	Price /Each
TLV311	PSFE100	3/4	100'	in/ft. - decimal ft.	88.00
TLV313	PSFE300	3/4	300'	in/ft. - decimal ft.	225.00
TLV314	PSFM030CME	3/4	30 m/100'	in/ft. - mm/cm/m	114.60

SMALL MEASURING WHEELS

- Small wheel ideal for flat surfaces
- Dial indicator measures up to 999' 11" without resetting
- Telescoping handle reduces to 17" for easy storage
- Measure as fast as you can walk
- Fits in most briefcases



CRESCENT Lufkin

Model No.	Mfg. No.	Measures	Graduations	Price /Each
TJ797	MW18TP	Imperial	in/ft.	48.20

PROFESSIONAL MEASURING WHEEL

- Centerline wheel for increased balance and more accurate measurements
- Bolstered folding joint allows for compact storage and longer product life
- Gear-based measuring system is more accurate and durable than traditional belt-style counter
- Heavy-duty wheel wiper prevents debris buildup
- Easy-read non-glare counter
- Wheel Diameter: 12"/30.5 cm

TYX931



CRESCENT Lufkin

Model No.	Mfg. No.	Measuring Range	Graduations	Price /Each
TBU277	PSMW48N	9999'	Inches/Feet	94.00
TYX931	PSMW48NM	9999 m	Decimeter/Meter	94.00

DIGITAL DISTANCE MEASURING WHEEL

- Lightweight and easy to use, designed for professional and personal usage
- Large wheel model ensures accuracy and is ideal for uneven terrain
- Suitable for outdoor and indoor distance measuring applications
- Pistol grip handle for ergonomic comfort
- Backlight for low light conditions
- Metric and imperial measurement with 5 memory storage entries
- Accuracy of ±0.5%
- Telescopic handle
- Push button reset
- Adds forward, subtracts in reverse
- Equipped with a sturdy flip-down kickstand and carrying bag for easy storage and portability
- Wheel Diameter: 12.5"/31.8 cm
- Resolution: 0.1 m
- Power: 3V (2xLR3 Batteries)
- Suitable Temperature: -10°C - 45°C



AURORA TOOLS

Model No.	Measuring Range	Graduations	Price /Each
TYY302	99999.9 m	Feet/Metres	109.00

MEASURES, RULES, SQUARES & LEVELS

ATLAS® CHROME CLAD®/NUBIAN® DOUBLE DUTY OIL-GAUGING TAPE LINES

- Black markings bonded to steel, recessed beneath multiple layers of nickel and chrome electroplating
- Chrome Clad® and Nubian® (black) for dark (heavy) and light (clear) oils
- All tapes read right to left
- Heavy-duty frame designed for years of rugged use
- All frames include a grounding strap
- Plumb bob must be ordered separately



Model No.	Mfg. No.	Blade Width	Blade Length	Blade Graduations	Blade Reading	Price /Each
FOR INAGE GAUGING						
TBG548	CN1290SF590	1/2"	25'	in/ft.	1/8"	245.00
TBG549	CN1290SME	13 mm	26/8 m	in/ft. - m	1/8"/1 mm	257.00
QZ024	CN1293SF590	1/2"	50'	in/ft.	1/8"	284.00
TBG553	CN1293SMEF59	13 mm	50/15 m	in/ft. - m	1/8"/1 mm	332.00
TBG557	CN1295SF590	1/2"	75'	in/ft.	1/8"	376.00
TBG559	CN1295SME590	13 mm	75/23 m	in/ft. - m	1/8"/1 mm	423.00
TBG560	CN1296SF590	1/2"	100'	in/ft.	1/8"	467.00
TBG561	CN1296SMEF59	13 mm	100/30 m	in/ft. - m	1/8"/1 mm	552.00
FOR OUTAGE GAUGING						
TBG552	CN1293SF5871	1/2"	50'	in/ft.	1/8"	284.00
TBG554	CN1294SF5871	1/2"	66'	in/ft.	1/8"	339.00
TBG558	CN1295SME	13 mm	75/23 m	in/ft. - m	1/8"/1 mm	423.00

OIL GAUGING PLUMB BOBS

- Inage bobs are cylindrical shaped, 1" x 6 3/4" L
- Outage bobs are square shaped, 7/8" x 6" L
- Outage bobs Zero falls inside top of hook eye

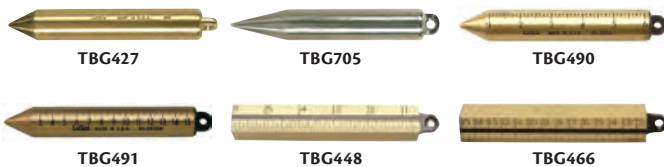

Model No.	Mfg. No.	Material	Graduations	Gauging Type	Weight oz.	Price /Each
TBG427	T1590	Brass	None	Inage	20	71.90
TBG705	S590N	Stainless Steel	None	Inage	20	148.00
TBG490	590GN	Brass	in.	Inage	20	92.00
TBG491	590GMN	Brass	mm/cm	Inage	20	92.00
TBG492	590GMEN	Brass	mm/in.	Inage	20	92.00
TBG448	58712N	Brass	in.	Outage	20	121.00
TBG466	T150MM	Brass	mm/cm	Outage	20	122.00

DIGITAL BOX LEVEL

- Removable shock-absorbing end caps
- Top read digital display
- Overhead inverted display
- 4 power saves modes
- Tilt indicator
- Precision milled edges
- High contrast e-Band™ solid block acrylic vials
- Includes: (1) Protective case, (2) AA batteries
- Angle Range: 0° - 90°



Model No.	Mfg. No.	Length"	Price /Each
UAE087	E105.24	24	195.00

EXTRA BOLD CHALK REEL

- Planetary gear system provides the longer gear life
- The 18 oz capacity allows for more lines between refills while an extra-large quick turn opening makes those refills easy
- Metal handle
- Line lock
- Case: Plastic
- Chalk not Included
- Retraction Ratio: 4:1



Model No.	Mfg. No.	Length	Price /Each
UAE090	48-22-3910	100'	43.50
UAE091	48-22-3915	150'	59.90

STANDARD MARKING CHALK REFILL

- Marking chalk for indoor or outdoor use
- Great for concrete, wood, or metal
- Provides great visibility
- Engineered flip-top cap that keeps the chalk in the bottle where you want it and stops it from spilling out in areas that you don't want it
- Weight: 8 oz.



TYP007

IRWIN STRAIT-LINE

Model No.	Mfg. No.	Description	Colour	Price /Each
TYX963	64901	Temporary	Blue	2.19
TYP007	64902	Permanent	Red	2.19

MAGNETIC TORPEDO LASER LEVELS, FLAT BOTTOM

- Built-in, rotating head changes from point to horizontal or vertical lines
- Cross-check vial for more accurate levelling
- Machined gauging edge
- Includes: Laser level, two AAA batteries and carrying case
- Magnetic
- Laser wave length: 650 nm ± 10 nm
- Laser classification: Class 111a
- Accuracy: ± 1/8" @ 50' (± 1 mm @ 5 m)
- Working range: Max. 100' (30 m) depending on light conditions
- Working temperature: 14°F to 113°F (-10°C to 40°C)



Model No.	Mfg. No.	Price /Each
TGZ561	40-6164	111.00

MEASURES, RULES, SQUARES & LEVELS

HIGH-ACCURACY LEVEL

- High accuracy vial with big bubble and 3 black lines each side
- Environmentally-friendly fluorescent liquid inside, which is anti-oxidation, anti-ultraviolet, and anti-electrostatic drift
- High strength aluminum profile
- Enhanced cross section design has high anti-bending resistance, so as to ensure constant accuracy and reliability
- Rubber handle cover features an ergonomic design for added comfort
- The end caps are covered by 2-component TPR material, making it anti-impact
- CNC milled bottom ensures a high accuracy reference base
- Type: Box
- Material: Aluminum
- No. of Vials: 3

AURORA
TOOLS



Model No.	Length'	Price /Each
UAV720	2	18.95
UAV721	4	36.95

REDSTICK™ DIGITAL LEVEL WITH PIN-POINT™ MEASUREMENT TECHNOLOGY

- Provides layers of information to include numeric, graphic, color and audio for advanced readability
- PIN mode allows user to lock in any target within 360° for replicating measurements or finding a specific measurement
- Utilizes Milwaukee's rechargeable Redlithium USB battery
- Auto brightness adapts the display to the external light automatically
- Includes: Level, 4.0 Redlithium USB Rechargeable Battery, USB Cord and Wall Plug, Level Case
- Angle Range: 0° - 90° • Accuracy: 0.03" • Type: Box Beam



UAE227

Model No.	Mfg. No.	Length"	Price /Each
UAE225	MLDIG14	14	305.00
UAE226	MLDIG24	24	367.00
UAE227	MLDIG48	48	405.00
UAE228	MLDIG72	72	449.00

Milwaukee

ALUMINUM TORPEDO LEVELS WITH MAGNETIC BASE

- Oversized solid aluminum base
- Oversized 1/2" diameter vials are easy to read
- V-grooved base for surface leveling and tubular work
- Strong magnetic base
- Model **TLV298** allows you to read slope in 1/8" increments

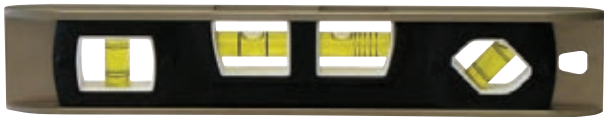

JOHNSON

Model No.	Mfg. No.	Description	Price /Each
TLV298	40-2212	12", 4 Vials Read Plumb, Level, Multi-Pitch, and 45°	41.00

ANGLE GAUGE & LEVEL

- This Digital Angle Gauge and Level can measure or set angles, check relative angles with zero calibration feature, or can be used as a digital level
- High visibility reverse contrast display improves visibility in dimly lit work environments
- Strong magnetic base to attaches to conduit, pipes, saw blades, vents, ducts, and other ferromagnetic surfaces
- V-groove edges enable optimal alignment on conduits and pipes for bending and alignment
- 0 to 90-Degree and 0 to 180-Degree measurement ranges provide easy use in applications such as woodworking, bending conduit, installing electrical panels, and working on machinery
- 0 to 180-Degree range is useful when accounting for kickback in pipe bending applications when bending to 90-Degree or more
- Display auto-rotates when upside-down for easy viewing
- Water and dust resistant with rating of IP42
- Soft carrying case and two AAA batteries included

Model No. UAV737
Mfg. No. 935DAG
Price/Each \$49.20

KLEIN TOOLS
For Professionals... Since 1857



I-BEAM LEVEL

- Lightweight and durable
- 0.0005" in accuracy in all working positions
- Impact resistant acrylic mono vials offer superior durability
- High contrast vial surrounds

- Improve vial visibility
- Top read window provides clear overhead viewing
- Material: Aluminum
- No. of Vials: 3

Empire



Model No.	Mfg. No.	Length"	Description	Price /Each
UAF102	500.24	24	Non-Magnetic	25.50
UAF105	500M.24	24	Magnetic	28.50
UAF103	500.48	48	Non-Magnetic	39.90
UAF106	500M.48	48	Magnetic	39.90
UAF104	500.72	72	Non-Magnetic	73.90
UAF107	500M.78	72	Magnetic	72.90

TRUE BLUE® TORPEDO LEVEL

- True Blue® vials are accurate to within 0.0005" per inch in all working positions
- 4 vials read plumb, level, 45 degree and Vari-Pitch™
- Full length magnetic edge
- Vari-Pitch™ vial reads slope in 1/8" increments
- Material: Aluminum
- No. of Vials: 4
- Magnetic



Empire

Model No.	Mfg. No.	Length"	Price /Each
TY0641	E80.9	9	14.90

MEASURES, RULES, SQUARES & LEVELS



RED BEAM SELF-LEVELING HORIZONTAL & VERTICAL ROTARY LASER

- Electronically-controlled dual slope feature
- Electronic self-leveling horizontally and vertically
- Laser beam modes include dot, two adjustable line lengths and two rotational speeds
- Includes: 1 Rotary Laser, 1 Remote Control, 1 Detector with Clamp, 1 Tinted Glasses, 1 Target, 1 Multi-Function Mount, 1 NiMH rechargeable battery pack, 1 6.4V battery adapter, 1 Alkaline battery compartment (batteries not included), 1 Hard-Shell Carrying Case, 1 Instruction Manual



TECHNICAL SPECIFICATIONS

Model No.	IB940
Mfg. No.	40-6534
Laser Wave Length:	635 Nm
Laser Class:	Class 111
Accuracy:	±1/8"/100 ft.
Interior Range:	Up to 200 ft. diameter depending upon light conditions
Exterior Range:	Up to 1500 ft. diameter with detector
Remote Range:	Up to 200 ft. diameter
Power Supply:	NiMH rechargeable battery pack and 6.4V adapter included
Working Temperature:	14°F-113°F
Scanning Modes:	0°, 30°, 60°
Rotational Speeds:	200 and 500 RPM
Price/Each	\$1610.00

GREEN BEAM SELF-LEVELING HORIZONTAL & VERTICAL ROTARY LASER

- Electronically-controlled dual slope feature
- Electronic self-leveling horizontally and vertically
- Laser beam modes include dot, two adjustable line lengths and two rotational speeds
- Includes: 1 Rotary Laser, 1 Remote Control, 1 Detector with Clamp, 1 Tinted Glasses, 1 Target, 1 Multi-Function Mount, 1 NiMH rechargeable battery pack, 1 6.4V battery adapter, 1 Alkaline battery compartment (batteries not included), 1 Hard-Shell Carrying Case, 1 Instruction Manual



TECHNICAL SPECIFICATIONS

Model No.	IB941
Mfg. No.	40-6544
Laser Wave Length:	532 Nm
Laser Class:	Class 111
Accuracy:	+/-1/8"/100 ft.
Interior Range:	Up to 400 ft. diameter depending upon light conditions
Exterior Range:	Up to 1200 ft. diameter with detector (not included)
Remote Range:	Up to 200 ft. diameter
Power Supply:	NiMH rechargeable battery pack and 6.4V adapter (included)
Working Temperature:	32°F-104°F
Scanning Modes:	0°, 30°, 60°
Rotational speeds:	200 and 500 RPM
Price/Each	\$1832.00

INTERIOR & EXTERIOR ROTARY LASER LEVEL KITS

- Horizontal self-leveling automatically aligns the laser to centre
- Protected rotary head and weatherproof design deliver interior and exterior jobsite durability
- Standby mode allows the user to pause the laser while transitioning from horizontal to vertical
- Equipped with leveling vial for manual leveling in vertical mode
- Includes: (2) D batteries, (1) Detector and clamp, (1) Wall mount, (1) Target card, (1) Contractor's bag, (1) 9-Volt battery



TECHNICAL SPECIFICATIONS

Model No.	TLY375
Mfg. No.	DW074KD
Laser Beam Colour:	Red
Laser Wave Length:	635 Nm
Laser Class:	Class IIIA
Accuracy per 100':	1/4"
Interior Range:	100'
Range with Detector:	600'
Rotation Speeds:	0, 60, 600 RPM
Self-Leveling Range:	±5°
Price/Each	\$739.00



TECHNICAL SPECIFICATIONS

Model No.	TMB038
Mfg. No.	DW089K
Accuracy:	±1/8" @ 30'
Power:	6 V, 4-AA Battery
Run Time:	30 hours
Price/Each	\$479.00

GREEN CROSS LINE LASER

- Provides 8+ hours of runtime for all-day brightness and is powered by (4) AA batteries
- The high-intensity laser beams allow our users to see the green lines up to 100' for fast and accurate leveling and alignment
- The integrated magnetic bracket features amplified rare earth magnets for a stronghold on metal surfaces while the screw and nail hang holes make setup easy and efficient in any environment
- 165' range with detector
- Locking pendulum
- IP54 rated for water and dust resistance
- Includes: (1) Green Cross Line Laser (3421), (4) AA Batteries, (1) Carrying Case
- Accuracy: +/- 1/8" @ 33 ft
- Thread Mount: 1/4"-20
- Self Leveling Range: +/- 4° Tilt
- Impact Resistance Rating: 1 m
- **Manufacturer's Warranty: 2 Years**

Model No. XJ123
Mfg. No. 3421
Price/Each \$362.00



M12™ GREEN CROSS LINE & 4-POINTS LASER

- Provides all-day runtime and the best visibility in its class
- Using the M12™ Redlithium™ 3.0 CP Battery (sold separately), users get 9+ hours of continuous runtime for ultimate productivity
- The high-intensity green laser offers users superior visibility up to 125' for long-range applications
- The vertical and horizontal lines make alignment and level applications easy for users, while the additional 4-points allow for quick transfers from floor to ceiling and squaring applications
- The integrated magnetic bracket features micro-control and pivots on the plumb point for easy and fast alignment
- The amplified rare earth magnets provide a stronghold and will not slide on steel studs, while an integrated hang hole makes setup easy and efficient in any environment
- Compatible with all M12™ batteries (sold separately)
- Pivots on point for increased control
- 165' range with detector
- IP54 rated for water and dust resistance
- Includes: M12™ Green Laser – Cross Line & 4-Points (3624-20), Carrying Case
- Accuracy: +/- 1/8" @ 33 ft
- Plumb Point Access: 2"
- Horizontal Fan Angle: 210°
- Vertical Fan Angle: 165°
- Thread Mount: 1/4"-20 & 5/8"-11
- Self Leveling Range: +/- 4° Tilt
- Impact Resistance Rating: 1 m
- **Manufacturer's Warranty: 3 Years**

Model No. XJ124
Mfg. No. 3624-20
Price/Each \$579.00



SELF-LEVELLING LINE LASERS (HORIZONTAL & VERTICAL)

- Accurate to +/- 1/8" @ 30' for level applications
- Built-in magnetic pivot bracket mounts easily on metal surfaces
- Overmolded housing for job site durability
- One button operation and control panel for ease of use
- Includes: 3 AA batteries for 20+ hours run-time and kit box



TECHNICAL SPECIFICATIONS

Model No.	TLZ506
Mfg. No.	DW088K
Power supply:	3 AA batteries
Self-Leveling Range:	5°
Indoor visibility range:	100'
Laser classification:	Class II
Price/Each	\$225.00



2-AXIS/3-BEAM LASER POINTERS

- Self-levelling plumb bob is accurate to ±1/4" @ 100'
- One button operation is fast and easy to use
- Overmolded housing helps maintain calibration under job site conditions
- Focused laser beam keeps dot small even over long distances for improved accuracy and visibility
- Locating magnets hold laser plumb bob to metal track for easy positioning
- Cross-hair beam pattern helps user find centre of beam
- Includes: Kit box



TECHNICAL SPECIFICATIONS

Model No.	TSW589
Mfg. No.	DW083K
Power supply:	4 AA Alkaline
Indoor visibility range:	+/- 100'
Laser classification:	Class II (<1.5 mW) @ 635 nm
Price/Each	\$275.00

Maintain the ideal temperature in your workplace

PLUMBING TOOLS

STRAIGHT PIPE WRENCHES

- Sturdy, cast iron housing and I-beam handle with full-floating forged hook jaw
- Nonstick adjustment nut, replaceable hook and heel jaws



RIDGID

Model No.	Cat. No.	Mfg. No.	Nom. Size in. mm	Pipe Capacity in. mm	Weight lbs. kg	Price /Each
TV792	31000	6	6 150	3/4 20	1/2 0.2	58.40
TV793	31005	8	8 200	1 25	3/4 0.3	64.80
TV794	31010	10	10 250	1 1/2 40	1 3/4 0.8	68.90
TV795	31015	12	12 300	2 50	2 3/4 1.2	75.10
TV796	31020	14	14 350	2 50	3 1/2 1.6	81.80
TV797	31025	18	18 450	2 1/2 65	5 3/4 2.6	121.00
TV798	31030	24	24 600	3 80	9 3/4 4.4	181.00
TV799	31035	36	36 900	5 125	19 8.7	432.00
TR181	31040	48	48 1200	6 150	34 1/4 15.6	693.00
TR182	31045	60	60 1500	8 200	51 1/4 23.3	1016.00

RAPIDGRIP™

- Quick one-handed operation
- Spring-loaded jaw design provides rapid ratcheting action



TCOX021

RIDGID

Model No.	Cat. No.	Mfg. No.	Nom. Size in. mm	Pipe Capacity in. mm	Fittings Cap. in. mm	Weight lbs. kg	Price /Each
TCOX021	10348	10	10 250	1 1/2 37.5	1 25	1.6 0.7	121.00
TCOX023	10358	14	14 350	2 50	1 1/2 37.5	3.1 1.4	137.00

PIPE WRENCHES

- Drop-forged alloy steel jaw
- Durable ductile steel body provides the ultimate in performance
- Precision milled sure gripping teeth
- Spring action ensures sure grip and quick release



UAL053

TJZ106

AURORA TOOLS

Model No.	Length"	Pipe Capacity"	Price /Each
STEEL HANDLE			
TJZ106	8	1	10.95
TJZ107	10	1 1/2	14.45
TJZ108	12	2	17.85
TJZ109	14	2	22.00
TJZ110	18	2 1/2	36.40
UAL050	24	3	69.80
UAL051	36	5	129.00
UAL052	48	6	229.00
ALUMINUM HANDLE			
UAL053	10	1-1/2	33.80
UAL054	12	2	43.95
UAL055	14	2	48.75
UAL056	18	2-1/2	81.95
UAL057	24	3	141.00
UAL058	36	5	249.00
UAL059	48	6	417.00

END PIPE WRENCHES

- Fast and easy grip for pipe working in restricted spaces or close to a wall



TR001

RIDGID

Model No.	Cat. No.	Mfg. No.	Nom. Size in. mm	Pipe Capacity in. mm	Weight lbs. kg	Price /Each
TR001	31050	E-6	6 150	3/4 20	1/2 0.2	72.40
TR002	31055	E-8	8 200	1 25	3/4 0.3	74.90
TR003	31060	E-10	10 250	1 1/2 40	1 3/4 0.8	81.50
TR004	31065	E-12	12 300	2 50	2 3/4 1.3	93.00
TR005	31070	E-14	14 350	2 50	3 1/2 1.6	104.00
TR006	31075	E-18	18 450	2 1/2 65	5 3/4 2.6	147.00
TR007	31080	E-24	24 600	3 80	9 3/4 4.4	227.00

HEAVY-DUTY OFFSET PIPE WRENCHES

- Jaw opening parallel to the handle
- Narrow hook jaw head provides easy entry into tight spots



TR159

RIDGID

Model No.	Cat. No.	Mfg. No.	Nom. Size in. mm	Pipe Capacity in. mm	Weight lbs. kg	Price /Each
TR159	89435	14	14 350	2 50	2 1/4 1.0	142.00
TR160	89440	18	18 450	2 1/2 65	5 3/4 2.6	216.00
TR161	89445	24	24 600	3 80	9 3/4 4.4	329.00

COMPOUND LEVERAGE WRENCHES

- Unique design multiplies the turning force applied to a pipe
- Ideal for freeing locked couplings and joints frozen by age or damage



THX681

RIDGID

Model No.	Cat. No.	Mfg. No.	Nom. Size in. mm	Pipe Capacity in. mm	Weight lbs. kg	Price /Each
THX681	31375	S-2	- -	2 50	7 1/4 3.3	924.00
THX682	31380	S-4A	- -	5 125	33 1/2 15.2	1349.00

ALUMINUM HANDLE STRAIGHT PIPE WRENCHES

- Nearly 40% lighter than comparable cast iron models of the same size
- Jaws and all other parts identical to Ridgid® heavy-duty wrenches
- Also available with special hook and heel jaws for plastic-coated pipe



TR009

RIDGID

Model No.	Cat. No.	Mfg. No.	Nom. Size in. mm	Pipe Capacity in. mm	Weight lbs. kg	Price /Each
TR009	31090	810	10 250	1 1/2 40	1 0.4	97.40
TR010	47057	812	12 300	2 50	2 1/2 1.1	119.00
TR011	31095	814	14 350	2 50	2 1/2 1.1	131.00
TR012	31100	818	18 450	2 1/2 65	3 3/4 1.7	166.00
TR013	31105	824	24 600	3 80	6 2.7	256.00
TR014	31110	836	36 900	5 125	11 5.0	480.00
TR015	31115	848	48 1200	6 150	18 1/2 8.4	915.00

M12™ DRAIN SNAKE

- Unique, hybrid design provides the benefits of both handheld and floor based drain cleaners in one machine
- Fixed drum shield with flat base protects users and fixtures while providing maximum tool support for easy cable feed
- Redlink Plus™ Intelligence provides optimized performance and overload protection using total system communication between tool, battery and charger
- Removable Inner Drum
- Slide action cable lock
- Drum Capacity: 1/4" x 25' and 5/16" x 25'
- Spinner Mode: Electric
- Maximum Drain Line Capacity: 1-1/4" - 2-1/2" up to 25'
- RPM: 0 - 500 • Voltage: 12 V
- Includes: (1) M12™ Drain Snake (Tool Only), (1) 5/16" X 25' Bulb Cable, (1) 5 Gallon Drain Snake Storage Bucket, (1) M12™ Lithium-ion Battery Charger, (1) M12™ Redlithium™ CP1.5 Battery Pack



Model No.	Mfg. No.	Description	Price /Each
UAE152	2571-21	M12™ Drain Snake Kit	411.00

MX FUEL™ SEWER DRUM MACHINE WITH POWERTREDZ™

- PowerState™ brushless motor
- The drum is fully enclosed to provide the best protection against mess
- Redlink Plus™ Intelligence enables advanced communication between batteries and tools
- Integrated drum brake stops drum from spinning quickly after pedal is released
- Cable-Drive™ automatic feed & retract reduces user fatigue by eliminating the need to pull back the cable from the pipe
- Rapid Stop™ button quickly releases the bearings to prevent the cable from binding
- One-Key™ technology allows for customization, tracking, tool security, and inventory management
- Drum plug at the bottom of machine provides an easy way to remove the water contained on the machine
- PowerTredz™ Lift Assist technology allows for one-person transportation of the machine up and down stairs as well as in and out of a service van
- Model **UAI603** includes: MX Fuel™ Sewer Drum Machine with PowerTredz™, 3/4" Anchor cable, MX Fuel™ CP203 battery pack, MX Fuel™ charger
- Drum Capacity: 5/8" x 100' and 3/4" x 100'
- Spinner Mode: Electric
- Drain Line Capacity: 200'
- Recommended Pipe Sizes: 3" - 6"
- Max. Pipe Size: 8"
- Cable Capacity: 5/8" & 3/4"
- Cable Spin Speed: 200 RPM
- Feed Type: Manual or Automatic
- Charge Time: 45 min.
- Weight: 125 lbs.

UAI603



Model No.	Mfg. No.	Description	Price /Each
UAI603	MXF501-1CP	MX Fuel™ Sewer Drum Machine with PowerTredz™	5237.00
UAI577	MXFCP203	Battery Pack, 3 Ah	519.00
UAI578	MXFXC406	Battery Pack, 6 Ah	846.00

M12™ AIRSNAKE™ DRAIN CLEANING AIR GUN



- Clears through drain covers and traps with powered air
- Removes grease and sludge from pipe walls and clear clogs past vent stacks
- Variable pressure control to select the right PSI for compression fittings and older drain lines
- Interchangeable attachments optimized for seals on drains, permanent drain stoppers, and toilets
- 15° offset connector for drain access under fixed faucets
- Drain Line Capacity: 1" - 4", over 35'
- Pressure: 0-50 PSI
- Voltage: 12 V
- Includes: (1) M12™ Airsnake™ drain cleaning air gun, (3) Drain plug attachments, (1) Drain shroud attachment, (1) 15° Connector, (3) Straight connectors, (1) Toilet seal attachment, (1) Airsnake™ 10" extension, (1) Carrying case, (1) M12™ Redlithium™ CP2.0 battery, (1) M12™ lithium ion battery charger



Model No.	Mfg. No.	Description	Price /Each
UAF956	2572B-21	M12™ Airsnake™ Drain Cleaning Air Gun Kit	609.00

M18 FUEL™ PIPE THREADER

- Auto-Stop™ kickback control
- Side grip and die head retention lock for no engagement with spinning die head
- Offset die head for closer threading near pipe bends and against walls
- One-Key™ technology allows for tracking, tool security, and inventory management
- Powerstate™ Brushless Motor provides more power, more run-time, and longer life
- Redlink Plus™ Intelligence enables advanced communication between batteries and tools
- Compatible with Ridgid® 12-R and Reed R12+ die heads
- Spindle Speed: 41 RPM
- Pipe Threading Capacity: 1/8" - 2"
- Power Source: Cordless
- Voltage: 18 V
- Includes: M18 Fuel™ pipe threader with One-Key™, Threading support arm, Carrying case, (2) M18 Redlithium™ High Output™ HD12.0 battery packs



Model No.	Mfg. No.	Description	Price /Each
UAF981	2874-22HD	M18 Fuel™ Pipe Threader Kit	2945.00

M12™ COPPER TUBING CUTTERS



- Close quarter rotating cutting head cuts pipe in confined spaces
- Automatic adjustment from 3/8" - 1" tubing
- Auto locking mechanism delivers up to 200 cuts per charge
- Water resistant sealed metal cutter head
- Battery fuel gauge
- Built-in LED light
- Includes: (1) M12™ Cordless Copper Tubing Cutter, (1) M12™ Lithium-ion Battery Charger, (1) M12™ Redlithium™ CP1.5 Battery, (1) Carrying Case

Model No. TLZ366
Mfg. No. 2471-21
Price/Each \$322.00



PLUMBING TOOLS

STRAIGHT PIPE WRENCHES

- Sturdy, cast iron housing and I-beam handle with full-floating forged hook jaw
- Nonstick adjustment nut, replaceable hook and heel jaws



ALUMINUM HANDLE STRAIGHT PIPE WRENCHES

- Nearly 40% lighter than comparable cast iron models of the same size
- Jaws and all other parts identical to Ridgid® heavy-duty wrenches
- Also available with special hook and heel jaws for plastic-coated pipe



RIDGID

Model No.	Cat. No.	Mfg. No.	Nom. Size		Pipe Capacity		Weight		Price /Each
			in.	mm	in.	mm	lbs.	kg	
TV792	31000	6	6	150	3/4	20	1/2	0.2	58.40
TV793	31005	8	8	200	1	25	3/4	0.3	64.80
TV794	31010	10	10	250	1 1/2	40	1 3/4	0.8	68.90
TV795	31015	12	12	300	2	50	2 3/4	1.2	75.10
TV796	31020	14	14	350	2	50	3 1/2	1.6	81.80
TV797	31025	18	18	450	2 1/2	65	5 3/4	2.6	121.00
TV798	31030	24	24	600	3	80	9 3/4	4.4	181.00
TV799	31035	36	36	900	5	125	19	8.7	432.00
TR181	31040	48	48	1200	6	150	34 1/4	15.6	693.00
TR182	31045	60	60	1500	8	200	51 1/4	23.3	1016.00

RIDGID

Model No.	Cat. No.	Mfg. No.	Nom. Size		Pipe Capacity		Weight		Price /Each
			in.	mm	in.	mm	lbs.	kg	
TR009	31090	810	10	250	1 1/2	40	1	0.4	97.40
TR010	47057	812	12	300	2	50	2 1/2	1.1	119.00
TR011	31095	814	14	350	2	50	2 1/2	1.1	131.00
TR012	31100	818	18	450	2 1/2	65	3 3/4	1.7	166.00
TR013	31105	824	24	600	3	80	6	2.7	256.00
TR014	31110	836	36	900	5	125	11	5.0	480.00
TR015	31115	848	48	1200	6	150	18 1/2	8.4	915.00

MIDGET TUBING CUTTERS

NOS. 101, 103, 104, 117 & 118

- For use in restricted spaces on small diameter, hard and soft copper, aluminum, brass, and plastic tubing
- Strong, lightweight slide and wheel housing, and large knurled feed screw knob give easy control of cutting pressure for clean cuts
- Self-feeding cutter wheel automatically cuts after tightening the knob only once
- Model TTX925 features a special knob for easier tightening of the feed screw



RIDGID

Model No.	Cat. No.	Mfg. No.	Description	Std. Wheel	Capacity		Weight		Price /Each
					in.	mm	lbs.	kg	
TR043	40617	101	Midget Cutter with Spare Wheel	E-3469	1/4-1 1/8	6-28	1/2	0.23	51.60
TR166	32975	103	Midget Cutter	E-3469	1/8-5/8	3-16	1/3	0.15	39.00
TR167	32985	104	Midget Cutter	E-3469	3/16-1 5/16	5-24	1/3	0.15	37.70
TTX925	97787	117	Self-Feeding Midget Cutter	E-3469	3/16-1 5/16	5-24	1/3	0.15	49.10
TSX282	86127	118	Self-Feeding Midget Cutter	E-3469	1/4-1 1/8	6-28	5/8	0.28	66.40

STANDARD TUBING CUTTERS

NOS. 10, 15, 20, 30, & 15-SI

- Clean, square cuts are easily made on copper, brass, aluminum, and thin-wall conduit
- Models TR046 – TR051 feature a convenient fold-away reamer
- TR052 and TR053 are rated for larger diameter steel and stainless steel tubing
- TTX876 is especially designed for stainless steel tubing



RIDGID

Model No.	Cat. No.	Mfg. No.	Description	Std. Wheel	Capacity		Weight		Price /Each
					in.	mm	lbs.	kg	
TR046	32910	10	Screw Feed Cutter*	F-158	1/8-1	3-25	7/8	0.40	69.30
TR047	32915	10	Above w/H-D Wheel*	E-1240	1/8-1	3-25	7/8	0.40	77.90
TR048	32920	15	Screw Feed Cutter*	F-158	3/16-1 1/8	5-28	1 1/2	0.68	77.20
TR049	32925	15	Above w/H-D Wheel*	E-1240	3/16-1 1/8	5-28	1 1/2	0.68	88.80
TR050	32930	20	Screw Feed Cutter*	F-158	5/8-2 1/8	16-54	1 3/4	0.80	156.00
TR051	32935	20	Above w/H-D Wheel*	E-1240	5/8-2 1/8	16-54	1 3/4	0.80	169.00
TR052	32940	30	Screw Feed Cutter	E-2558	1-3 1/8	25-79	3 1/2	1.60	239.00
TR053	32950	30	Above w/H-D Wheel	E-2191	1-3 1/8	25-79	3 1/2	1.60	259.00
TTX876	97212	15-SI	Stainless Steel Cutter	E-1525	3/16-1 1/8	5-28	1 1/2	0.68	122.00

* Now available with spare cutter wheel and extra large knob for easier tightening of feed screw.

PLASTIC PIPE & TUBING CUTTERS

- Designed for quick, clean cuts through plastic pipe and tube
- Cutters are easy-to-use, can cut most types of plastic and rubber pipe or tubing
- One-hand operation
- Replaceable stainless steel cutting blade folds into handle for safe handling and carrying
- Ratcheting models are constructed of durable aluminum

RIDGID



Model No.	Cat. No.	Mfg. No.	Description	Repl. Blade	Capacity (OD)		Weight		Price /Each
					in.	mm	lbs.	kg	
TLZ428	23493	PC-1375	Single Stroke Cutter	TLZ429	1 3/8	35	0.70	0.32	78.40
TLZ276	23488	PC-1250	Scissor-Style Cutter	TLZ277	1 5/8	42	0.45	0.20	38.80
TLZ268	23498	RC-1625	Ratchet Action Cutter	TLZ432	1 5/8	42	1.15	0.52	156.00
TLZ430	30088	RC-2375	Ratchet Action Cutter	TLZ431	2 3/8	63	1.88	0.85	243.00

STAY-BRITE® SILVER SOLDERS

- Stay-Brite® 1/16" x 1-lb spool
- Stay-Brite® and Stay-Brite® 8 silver bearing solders are often used instead of brazing alloys throughout the refrigeration/air conditioning industry
- Bond with most all ferrous and nonferrous alloys
- Joints exhibit considerably higher-than-necessary elongation for sound, dissimilar metal joints and vibration applications
- Stay-Brite® #8 is especially effective in filling loosely-fitted couplings
- Typical Application: Use for all metals with the exception of aluminum. Low temperature solder used in HVAC joints
- Type: Lead-free
- Chemical Composition: 4% Ag, 96% Sn
- Specification: ASTM B32 Sn 96, NSF 51, J-STD-006 Sn96Ag04A
- Solidus: 430°F/221°C
- Liquidus: 430°F/221°C

Model No. 848-1055
Mfg. No. SB31
Price/Each \$155.00



LEAD FREE SOLDER

- Bridgit® 1/8" x 1-lb spool lead free solder
- Bridgit® is a non-toxic solder alloy that exceeds the physical advantages of lead-tin solders
- Contains nickel, making joints tremendously strong
- Wide plastic range makes this an excellent alloy for large diameter fittings and ill-fitted or non-concentric pipes
- Fills gaps and caps off easily and effectively
- Typical Application: Wide plastic range makes this an excellent alloy for large diameter fitting and ill-fitted or non-concentric pipes
- Specifications: ASTM B32 HB NSF 61 Conforms to 1986 U.S. Safe Drinking Act
- Solidus: 460°F/238°C • Liquidus: 630°F/332°C

Model No. 848-1035
Mfg. No. BRGT61
Price/Each \$47.50



M12™ FORCE LOGIC™ PRESS TOOL KIT WITH JAWS

- Accommodates M12™ 1-1/4" press jaw (sold separately)
- Batteries recharge in 30 minutes
- Compatible with all M12™ batteries & chargers
- Cut, fasten and connect all on one system
- Performs 32 000 crimps between service inspections
- Can be operated with one hand while delivering up to 5400 lbs. of force
- Voltage: 12 V
- Length: 12.6"
- Includes: (1) M12™ Force Logic™ Press Tool, (1) M12™ 3/4" Jaw, (1) M12™ 1/2" Jaw, (1) M12™ 1" Jaw, (1) M12™ Lithium-ion Battery Charger, (2) M12™ Redlithium™ CP1.5 Battery Pack, (1) Hard Carrying Case

Model No. TMB769
Mfg. No. 2473-22
Price/Each \$3171.00



TEFLON SEALING TAPE

- Commonly used in plumbing for sealing pipe threads
- Ensures a tight seal
- Works for both water and air
- Colour: White
- Tape Material: PTFE
- Thickness: 3 mils (0.0762mm)
- Density: 0.37 grams/cubic centimeter
- Working Temperatures Range: -190°C to 260°C (-310°F to 500°F)



Model No.	Width"	Length"	Price /Each
PG148	1/2	520	0.80
PG149	3/4	520	1.95

M12™ TRAPSSNAKE™ 2-TOOL COMBO AUGER KIT

- Integrated locking mechanism which holds the cable in place for easy telescoping extension and retraction
- Fixed rubber boot prevents porcelain scratches throughout the life of the tool
- The Trapsnake™ System allows for a dedicated power source to clear clogs in toilets, urinals, floor traps, sinks, bathtubs, and showers
- Available accessories: Trapsnake™ Toilet Auger Case (48-22-2577) and TRAPSSNAKE™ Urinal Auger Case (48-22-2577)
- Recommended Drain Size: Urinal (1-1/4 in. - 2 in) and Toilet (2 in. - 4 in.)
- Part of the M12™ System, Featuring over 100 tools
- Head Style: Bulb
- Cable Length: 6', 4'
- Cable Diameter: 3/8", 1/2"
- Kits include: (1) M12™ Trapsnake™ Driver, (1) M12™ Redlithium™ CP1.5 Battery, (1) M12™ Charger
- Manufacturer's Warranty: 5-year tool, 3-year Battery, 2-year cable



Model No.	Mfg. No.	Description	Price /Each
AUW176	3577-21	2-Tool Combo Auger Kit	304.00
AUW174	3574-21	4' Urinal Auger Kit	249.00
AUW177	48-53-3574	4' x 3/8" Replacement Cable	63.50
AUW175	3576-21	6' Toilet Auger Kit	249.00
AUW178	48-53-3576	6' x 1/2" Replacement Cable	52.80

M18™ FORCE LOGIC™ PRESS TOOL WITH ONE-KEY™ & CTS JAWS KIT

- 1/2"-4" capacity dependent on material and fitting system
- Lightest, in-line design for unrivaled access
- Auto-cycle ensures full press every time
- Industry's first brushless press tool
- Compatible with 20 unique fitting systems
- Pre-press battery check ensures tool won't start a press it can't complete
- One-Key™ wireless reporting allows user to monitor and report successful operation from desktop and mobile devices, to track tool location as well as to lock and disable tool remotely
- Brushless motor enables 20% more run time & 10% faster cycles
- Easy-open jaw for one-handed use
- Equipped with Redlink™ electronics, the cordless press tool also provides the highest level of press accuracy and reliability available in the industry
- Includes: (1) M18™ Force Logic™ Press tool with One-Key™, (2) M18™ Redlithium™ CP2.0 battery, (1) M18™ & M12™ Multi-voltage charger, (1) Carrying case, (1) M18™ 1/2" Jaw, (1) M18™ 3/4" Jaw, (1) M18™ 1" Jaw, (1) M18™ 1-1/4" Jaw, (1) M18™ 1-1/2" Jaw, (1) M18™ 2" Jaw
- Capacity: 1/2" - 4"
- Force: 7200 lbs.
- Approximate Cycle Time: 4 Seconds
- Calibration Interval: 50000
- Length: 14.1"
- Battery Type: 18V Lithium-Ion
- Manufacturer's Warranty: 2 Years Battery & 5 Years Tool

Model No. UAK311
Mfg. No. 2922-22
Price/Each \$5454.00



KLETON



**CREATE UNIQUE SOLUTIONS
THAT ARE BUILT TO LAST.**



Look for the "K" Custom symbol
for customizable products



TOOL BELTS

1 1/2" INDUSTRIAL BELTS

- Made of top grain leather
- 1 1/2" width with heavy roller buckle
- Trim to fit waist sizes 29" – 46"

Model No. TN233 Price/Each \$19.16



2" INDUSTRIAL BELTS

- Made of top grain leather
- 2" width, with heavy-duty roller buckle
- Trim to fit waist sizes 29" – 46"

Model No. TN234 Price/Each \$22.76



2" DOUBLE TONGUE BELTS

- Made of top grain leather
- 2" width with heavy-duty double tongue roller buckle
- Trim to fit waist sizes 29" – 46"

Model No. TP207 Price/Each \$22.91



2" WEB WORK BELTS

- Heavy-duty poly web
- Features quick-release buckle design
- Fits waist sizes 29" to 46"
- Colour: Black

Model No. TAW990 Price/Each \$11.60



5" WIDE PADDED COMFORT BELTS

- Heavy-duty double layer lightweight fabric will not rot, crack, harden or mildew
- 2" double tongue roller buckle
- Foam padding
- Grip-Strip™ fastening system holds pouches securely in place
- Fits waist sizes 29"-46"

Model No. TBN140 Price/Each \$38.12



WIDE PADDED BELT

- Features extra foam padding
- Features Grip-Strip™ system to securely hold pouches in place
- Fits waist sizes 29"-46"
- Colour: Black
- Material: Polyester
- Belt Width: 2"

Model No. TBN133 Price/Each \$32.52



TOOL BELTS

A. LIGHTWEIGHT TOOL BELTS

- Leather fabrication
- Designed to carry lightweight tool pouches

B. HEAVY-DUTY EMBOSSED TOOL BELTS

- Strong, heavy-duty leather
- Equipped with a double-tongue buckle

C. LIGHTWEIGHT UTILITY BELTS

- Strong, lightweight, synthetic-web
- Quickly adjusts for waist sizes through 52"
- Accepts tunnel-loop and slotted pouches and holders
- Tough, molded, non-metallic, slide-action buckle provides single-handed, quick release and adjustment

D. GENERAL-PURPOSE BELTS

- Strong, heavy-duty leather
- Removable single-tongue buckle held by two heavy-duty snaps

A.



C.



B.



D.



	Model No.	Colour	Size	Belt Width"	Wt. lbs.	Price /Each
A.	TBS851	Black	33"-45"	1	0.30	22.40
B.	TBS856	Tan	36"-44"	2	0.64	54.30
	TBT510	Tan	40"-48"	2	0.64	54.30
	TBT512	Tan	44"-52"	2	0.65	53.10
C.	TBS852	Blue	One Size Fits All	2	0.20	16.80
D.	TBT501	Black	32"-40"	1 1/2	0.40	46.90
	TBT500	Black	38"-46"	1 1/2	0.45	48.80
	TBT502	Black	46"-54"	1 1/2	0.50	50.50

HEAVY-DUTY WORK SUSPENDERS

- Adjustable to fit all sizes
- Heavy-duty clips on front and rear
- 2" wide heavy-duty elastic straps
- Nylon stitched for durability

Model No. TP208 Black Price/Each \$19.11

Model No. TBN236 Red Price/Each \$19.11



PADDED CONSTRUCTION SUSPENDERS

- Designed to transfer weight from waist to shoulders
- Fully adjustable length, front and back to fit all sizes
- Heavy-duty padding for user comfort
- Heavy-duty nylon web for extra strength
- Convenient quick fastening system

Model No. TBN243 Price/Each \$42.92



TOOL STORAGE

UTILITY POUCHES

- Made of split grain leather
- Material: Leather
- Colour: Black

AURORA
TOOLS



UAV349



UAV350



UAV351



UAV352



UAV353



UAV354



UAV355



UAV356



UAV357

Model No.	No of Pockets	Description	Length"	Height"	Price /Each
UAV349	2	Knife Holder	7-3/4	2-3/4	8.80
UAV350	3	Knife Holder	11-3/4	4-3/4	10.00
UAV351	1	Plier Holder	3-1/2	9	10.60
UAV352	1	Plier Holder, Knife Holder	8-1/2	2-1/2	6.75
UAV353	1	Tape Measure Holder	6-3/4	4-1/2	7.90
UAV354	1	Plier Holder	2-1/2	8-1/4	8.25
UAV355	1	Plier Holder	9	3-1/4	9.55
UAV356	3	Multiple Tool Holder	6-1/4	9-1/4	23.95
UAV357	-	Hammer Holder	3-3/4	5 1/2	4.45

TOOL POUCHES

AURORA
TOOLS



TER023



TER024



TER025



TER026



TER027

Model No.	Number of Pockets	Description	Overall Dimensions			Price /Each
			W"	x D"	x H"	
TER023	8	All-Purpose Gear Bag	24	x 12	x 12	49.95
TER024	5	Maintenance Tool Pouch	3-1/2	x 1-1/2	x 8-3/4	19.20
TER025	3	Utility Knife Holder	6	x 3-1/2	x 9-3/4	9.90
TER026	4	Multi-Pocket Phone & Tool Holder	6-1/4	x 2	x 9-1/2	14.70
TER027	4	Multi-Purpose Tool Holder	5-1/4	x 2	x 7-1/2	11.60

CELL PHONE HOLDER

- Includes 1 large pocket and smaller elastic pockets on the side
- Features padded interior to protect cell phone
- Features heavy-duty clip
- Material: Polyester
- Colour: Black
- No. of Pockets: 4
- Style: Cell Phone Holder
- Interior Dimensions: 2-3/4" W x 3/4" D x 5-1/4" H

Model No. TEQ768
Price/Each \$15.47



UTILITY POUCHES

- Made of full grain leather
- Holds a knife, pencil, felt marker and other miscellaneous tools
- Excellent for warehousing and utility use
- Dimensions: 4 3/4" L x 11.75" H

Model No. TP214
Price/Each \$13.64



11-POCKET PROFESSIONAL ELECTRICIAN'S POUCHES

- Double layer of rugged, lightweight nylon
- Two large main pockets, three smaller pockets
- Six large screwdriver holders, electrical tape chain and tool snap
- Metal clip holds all measuring tape sizes
- Dimensions: 8 1/2" L x 14 1/2" H

Model No. WI969
Price/Each \$58.41



UTILITY KNIFE, PEN/PENCIL HOLDERS

- Made of full grain leather
- Designed to fit pen/pencil and utility knife
- Comes with quick release snap belt loop
- Dimensions: 7 3/4" L x 2 3/4" H

Model No. TBN197
Price/Each \$11.94



MAINTENANCE TOOL POUCHES

- Double zipper that keeps the tools in place and accommodate longer tools
- Push-button that keeps the cover away from the tools access
- Several compartments can store a wide variety of tools
- Carabiner and tape holder
- Belt clip that fits belts up to 2 3/4" wide
- Dimensions: 6" L x 9 3/4" H

Model No. TEP259
Price/Each \$23.82



8-POCKET ELECTRICIAN'S TOOL POUCHES

- Top grain leather
- One main deep pocket, six additional front and side pockets for screwdrivers, wrenches, etc.
- Fits belts up to 2 3/4" wide
- Leather hammer loop
- Leather holder fits up to 30" measuring tape
- Tape chain and metal tool clip
- Dimensions: 10 1/2" L x 11" H

Model No. TBN138
Price/Each \$49.86



MULTI-PURPOSE TOOL HOLDERS

- Four pockets made of ballistic nylon
- Versatile 3-way attachment for pants, web suspenders, work aprons, etc.
- Securely holds small tools or accessories like pliers, mini flashlights, screwdrivers, etc.
- Dimensions: 5 1/4" L x 8 1/2" H

Model No. WI957
Price/Each \$13.97



4-WAY LINEMAN TOOL POUCHES

- Made for pliers, screwdriver, ruler, adjustable wrenches and knife snap
- Pliers do not protrude from this pouch
- Bottom is vented to prevent collection of dirt
- Slotted to fit belt up to 2" wide
- Double backed and riveted
- Top grain leather
- Dimensions: 9 1/2" L x 7" H

Model No. TBN205
Price/Each \$44.33



SNIPS, PENS & TAPE HOLDER

- Made of polyester fabric
- Designed for utility and "lock-back"-style knives, pliers or snips
- Sleeves for pens, markers, carpenter's pencils, with integral measuring tape clip
- Material: Polyester
- Colour: Black
- No. of Pockets: 1
- Style: Knife Holder

Model No. TEP509
Price/Each \$11.93



MULTI POCKET TOOL & PHONE HOLDERS

- Attached to belt with snap closure or wide padded flap
- Four pockets and one padded pocket with elastic binding sized to fit most compact cell phones
- Detachable electrical tape sling
- Dimensions: 6" L x 11" H

Model No. TJZ972
Price/Each \$18.29



TAPE HOLDERS

- Made of top grain leather
- Designed to fit up to 30" tapes
- All rivet construction
- Dimensions: 6 3/4" L x 4 1/2" H

Model No. TBN166
Price/Each \$9.45



TOOL POUCHES

- Made of full grain leather
- Designed to fit assorted utility items: pens, markers, tape, utility knife, etc.
- 2" wide belt slots
- Rivet reinforced
- Dimensions: 3 1/4" W x 9" H

Model No. TSW497
Price/Each \$14.36



TOOL STORAGE

BUCKETBAG™ TOOL BAG

- Features drawstring system to keep tools in place
- Colour: Black
- Material: Polyester
- No. of Pockets: 18
- Model No. TEQ933**
Price/Each \$21.74



BIGMOUTH® TOOL BAG

- Features heavy-duty stitching and reinforce stress points
- Features 17 pockets inside and 6 pockets outside
- Features extra padding on handles
- Colour: Black
- Material: Polyester
- No. of Pockets: 23
- Dimensions: 1 2" L x 8-1/2" W x 8" H
- Model No. TBN280**
Price/Each \$25.56



21-POCKET ZIPPERED PROFESSIONAL ELECTRICIAN'S TOOL POUCHES

- Zippered top flap to prevent spillage of tools when not in use
- Dimensions: 11 1/2" L x 16" H
- Made of polyester fabric and ballistic binding
- Rubber handle and padded shoulder strap for easy storage and carrying
- Outside pocket to hold cellphone
- Model No. TBN126**
Price/Each \$71.04



TOOL CARRIER

- Zippered inside panels prevent spillage of tools when carrying or storing carrier
- 52 Pockets inside and 6 outside to organize tools and accessories
- Large center compartment to carry power tools and accessories and 2 separate outside compartments
- Vertical tool pockets keep them in sight for quick access
- Colour: Black
- Material: Polyester
- No. of Pockets: 58
- Dimensions: 18" L x 7" W x 14" H
- Model No. NKB335**
Price/Each \$106.82



PACKOUT™ TOTE

- Part of the Packout™ modular storage system
- Impact-resistant molded base
- Colour: Red
- Material: Ballistic Nylon
- No. of Pockets: 32
- Model No. TEQ703**
Price/Each \$179.00



ULTIMATE JOBSITE BACKPACK

- Hardshell protected electronic and equipment pockets
- Impact-resistant base
- Length: 20"
- Width: 17"
- Colour: Black
- Material: Ballistic
- Model No. TEQ711**
Price/Each \$209.00



44-POCKET TOOL BACKPACK

- Large pads on back for extra comfort
- Adjustable padded shoulder straps
- Reinforced padded carrying handles
- Length: 16"
- Width: 13-1/4"
- Material: Polyester
- Model No. TEQ487**
Price/Each \$110.48



22-POCKET BIGMOUTH® BAGS

- Features 12-multi-use pockets inside and 10 outside
- Features padded web carrying handles and adjustable shoulder strap
- Includes reinforced stitching and bar tacking on stress point
- Ideal for organizing various tools and accessories of different sizes
- Model No. BB391**
Price/Each \$45.81



4-POCKET TOOL POUCHES

- Leather fabrication
- Riveted and stitched for extra durability
- Speciality add-ons: Knife snap
- Slotted belt connection
- Fits belts up to 2" wide
- Dimensions: 8 1/2" L x 10 3/4" H
- Model No. WK777**
Price/Each \$41.30



TRADESMAN PRO™ CELL PHONE HOLDERS

- Magnetic flap closure
- Metal clip for attached to belts up to 2" (51 mm) wide
- Constructed of 1680d ballistic weave
- Fits Samsung Galaxy S3®, S4®, S5®, Apple iPhone® 4, 5 & 6 and other similar sized phones
- Overall dimensions: 3 1/4" L x 1 1/2" W x 5 7/8" H
- Colour: Black
- Material: Ballistic Weave
- Model No. TUB329**
Price/Each \$37.90



ALL-PURPOSE GEAR BAGS

- All-purpose gear bag perfect for carrying air hoses, kneepads, power tools, extension cords, etc.
- Outside pockets to organize small tools or accessories
- Abrasion resistant rubber feet
- Reinforced padded carrying handles
- Dimensions: 24" L x 12" W x 12" H
- Model No. TEP215**
Price/Each \$47.48



75-POCKET TOOL BACKPACKS

- Enough interior panels to hold a multitude of tools including: 14-pc. wrench sets, electric drills, extension cords, pliers, screwdrivers and much more
- 7" x 5" multi-compartment plastic tray included
- Dimensions: 13" L x 17 1/2" W x 9" H
- Made of ballistic poly fabric
- Model No. TBN248**
Price/Each \$168.90



PACKOUT™ TOOL BAG

- Impact-resistant molded base connects with all other Packout™ system components via integrated locking cleats
- Reinforced side walls
- Tear-resistant 1680D ballistic material
- Spacious storage compartment
- Heavy-duty metal zippers
- Cushioned shoulder strap, top handles and side handles allows for easy and comfortable transport
- Colour: Black/Red
- Material: Ballistic Nylon
- No. of Pockets: 2
- Length: 15"
- Width: 9.6"
- Height: 12.2"

Model No. TEQ856
Price/Each \$79.98



48-POCKET BUCKET BUDDY

- 14 double row pockets inside and 34 triple row pockets outside organize a wide range of tools and accessories
- Security pocket with hook and loop closure
- Drill pocket with hook and loop handle strap
- Designed to fit most 3 1/2 - 5 gallon buckets
- Measuring tape strap and key clip included

Model No. VQ267
Price/Each \$28.35



LXT TOOL BAG WITH WHEELS

- Weather-resistant, durable nylon Cordura construction
- Ideal for multiple piece combo kits and large power tools
- Internal pockets feature straps to retain tools during transit
- External pockets for storage of accessories and more
- Colour: Black/Blue
- Material: Nylon
- No. of Pockets: 13
- LED Light Feature: Not Included

Model No. TEQ899
Price/Each \$109.00



TECH GEAR™ LED LIGHTED 14" BIGMOUTH® TOOL BAGS

- Built-in LED light can be easily directed at work area or into tool bag to help identify tools and parts
- Three levels of light output allows adjustment for wide area illumination or close-up work
- Bigmouth™ design gives easy access to tools and accessories
- 11 multi-use pockets inside and 18 outside to help better organize your tools
- Padded web carrying handles and adjustable shoulder strap
- Base pad feet to help reduce wear and abrasion
- Powered by two AAA batteries (batteries included)
- Dimensions: 14" L x 8" W x 11 1/2" H

Model No. TEP511
Price/Each \$81.99



23-POCKET LARGE ELECTRICAL & MAINTENANCE TOOL CARRIERS

- 11" x 6" multi-compartment plastic tray included that slides securely into bottom of tool carrier to organize small parts
- 16 multi-use outside pockets and 7 inside pockets to organize a wide range of tools and accessories
- Box shaped design prevents tipping over
- Extra padded carrying handle and adjustable shoulder strap
- Electrical tape strap
- Dimensions: 11" L x 10" W x 19" H

Model No. TBN256
Price/Each \$74.91



TRADESMAN PRO™ ELECTRICIAN'S BACKPACK ORGANIZERS

- 39 pockets for tons of tool storage
- Orange interior for easy tool visibility
- Tough, durable bottom protects from harsh elements
- Large front pocket easily fits cables, small parts and tools
- 1680D ballistic weave for durability
- Dimensions: 14" L x 7" W x 18" H
- Colour: Black
- Material: Ballistic

Model No. TYO472
Price/Each \$165.00



OPEN TOP 20" SOFT SIDE TOOL BOXES

- Removable and adjustable metal frame partition slides securely into place to customize tool box to your storage needs
- Plastic reinforced internal pocket for utility knife or other tools
- Sturdy metal handle bar with molded foam grip for easy carrying
- Wide-open space below handles for easy access to tool carrier's main compartment
- 27 multi-use pockets and six webbing loops to organize a wide range of tools and accessories
- Adjustable, padded shoulder strap
- Dimensions: 20" L x 11" W x 11" H

Model No. TEP217
Price/Each \$102.92



TECHGEAR™ LED LIGHTED TOOL BAG

- LED light handle can be easily directed at work area or into tool carrier
- 3 levels of light output (39 lumens on max)
- Ergonomic handle design
- Convenient 15" open compartment
- Padded, adjustable shoulder strap
- Powered by two AAA batteries, included
- Material: Polyester
- No. of Pockets: 22
- Dimensions: 18" L x 9-3/4" W x 12" H

Model No. TEQ485
Price/Each \$95.03



OPEN TOP 14" SOFT SIDE TOOL BOXES

- Removable and adjustable metal frame partition slides securely into place to customize tool box to your storage needs
- Plastic reinforced internal pocket for utility knife or other tools
- Sturdy metal handle bar with molded foam grip for easy carrying
- Wide open space below handle for easy access to tool carrier's main compartment
- 21 multi-use pockets and 10 webbing loops to organize a wide range of tools and accessories
- Adjustable, padded shoulder strap
- Dimensions: 14" L x 11" W x 11" H

Model No. TJZ969
Price/Each \$82.13



TOOL STORAGE

TECHGEAR™ 53-POCKET TOOL BACKPACK

- Length: 16"
- Width: 13-1/4"
- Material: Polyester
- Handy, integrated 3-level LED light system
- LED light handle can be easily directed at work area or into tool carrier
- Reinforced carrying handles and adjustable shoulder straps
- Powered by two AAA batteries, included

Model No. TEQ489
Price/Each \$148.61



HEAVY-DUTY CANVAS BUCKETS

- Dimensions: 11" Dia. x 16" H
- Made of heavy-duty canvas material
- Back-braided lifting rope
- High strength top ring
- Plastic bottom section for strength and durability
- 150 lbs. load rating

Model No. TP204
Plastic bottom
Price/Each \$88.83

Model No. WL001
Leather bottom
Price/Each \$101.96



MEGAMOUTH™ TOOL BAG

- Features metal frame constructions
- Features 18 outside pockets and 13 inside pockets
- Features padded handles and adjustable strap
- Colour: Black
- Material: Polyester
- No. of Pockets: 31

Model No. TEQ935
Price/Each \$67.64



TOUGHSYSTEM®

- Durable structural foam box walls give robust structure to the stand alone units
- Integrated water seal in every unit for protection of contents and long life for your equipment

TYP053



TYP052



TYP058



Model No.	Description	Overall Depth"	Overall Height"	Overall Width"	Price /Each
TYP053	DS150 Small Case	21-11/16	6-5/16	13-5/16	73.00
TYP052	Tote	21-29/32	10-29/32	12-13/32	44.50
TYP058	DS Carrier	-	-	-	425.00

17-POCKET ELECTRICAL & MAINTENANCE TOOL POUCHES

- Top grain leather
- Colour: Beige
- No. of Pockets: 17
- Box-shaped design prevents tipping
- Large divided main pocket for extra tool capacity
- Leather reinforced carrying handle and electrical tape chain

Model No. VE823
Price/Each \$179.61



TSTAK^{MD}

- The TStak® system is a flexible platform that allows for many different combinations based on the user's needs

TYP042



TYP044



TYP045



TYP047



TYP048



TYP046



TYP050



Model No.	Description	Overall Depth"	Overall Height"	Overall Width"	Price /Each
TYP042	Tool Box with Single Deep Drawer	16-11/16	6-7/8	2-1/4	69.50
TYP044	Tool Box with Double Shallow Drawers	17-5/16	6-29/32	6-5/16	79.90
TYP045	Organizer with Clear Lid	17-5/16	5-19/32	13	63.90
TYP047	Tool Box with Flat Top	17-5/16	13	6-1/2	48.50
TYP046	Deep Box	17-5/16	13	11-29/32	67.90
TYP048	Tool Box with Long Handle	17-5/16	13	6-5/16	61.90
TYP043	Tool Cart	-	-	-	105.00
TYP050	Trolley	-	-	-	219.00

PACKOUT™

- Modular storage system
- IP65 rated weather seal protects your tools, accessories, and small parts from rain and other jobsite debris
- Constructed with impact-resistant polymers



Model No.	Mfg. No.	Description	Overall Width"	Overall Depth"	Overall Height"	Price /Each
TEQ706	48-22-8426	Rolling Tool Box	19	22	26	179.00
TEQ707	48-22-8425	Tool Box	16	22	11	116.00
TEQ708	48-22-8424	Tool Box	16	22	7	104.00
TER110	48-22-8442	2-Drawer Tool Box	14-1/3	16-1/3	22-1/5	209.00
TER111	48-22-8443	3-Drawer Tool Box	14-1/3	16-1/3	22-1/5	239.00
UAJ143	48-22-8422	Tool Box Compact	16-1/5	10	13	99.98
TEQ709	48-22-8430	Tool Box Organizer	15	20	5	69.98
TEQ710	48-22-8435	Tool Box Organizer	15	10	5	49.98
TEQ858	48-22-8431	Low-Profile Organizer	16-2/5	19-3/4	2-1/2	59.98
TEQ859	48-22-8436	Low-Profile Organizer	9-3/4	16-2/5	2-1/2	39.98
TEQ860	48-22-8450	Tool Case w/Customizable Insert	14-4/5	-	-	109.00
TEQ861*	48-22-8451	Customizable Foam Insert	-	-	-	32.98
UAV606	49-66-6832	Removable Tray Socket Organizer, 15 Pieces	-	-	-	16.00
UAV607	49-66-6833	Removable Tray Socket Organizer, 16 Pieces	-	-	-	16.00
UAV604	49-66-6830	Removable Tray Socket Organizer, 17 Pieces	-	-	-	16.90
UAV605	49-66-6831	Removable Tray Socket Organizer, 19 Pieces	-	-	-	16.90
UAV608	49-66-6834	Removable Tray Socket Organizer, 27 Pieces	-	-	-	16.00
TER104	48-22-8415	2-Wheel Cart	-	-	-	319.00
TER116	48-22-8480	Racking Kit	-	-	-	189.00
TEQ863	48-22-8301	48-Pocket Backpack	15-3/4	11-4/5	15-3/4	181.00

*Fits in TEQ708, TEQ707, TEQ860

TOOL STORAGE

TOUGH CHEST™ MOBILE STORAGE

- Telescopic, metal pull handle for easy maneuvering
- Heavy-duty wheels for easy steering on job-site
- Overall Depth: 38-29/32"
- Overall Height: 24-5/16"
- Overall Width: 23-3/32"
- Capacity: 63 Gal

Model No. TYP060
Price/Each \$215.00



MULTI-LEVEL WORKSHOP

- Single pull-up latch for quick and easy opening
- Creates workstation for storage of large tools in bottom bin, organization of small parts in middle compartments, and top tool box
- Overall Depth: 21-1/2"
- Overall Height: 28-13/16"
- Overall Width: 16-3/16"

Model No. TYP061
Price/Each \$209.00



CONTRACTOR CHEST

- One-touch latch for quick and easy opening
- Telescopic, metal pull handle for easy maneuvering
- IPX3 water resistance to help protect tools from water damage
- Overall Depth: 24-13/16"
- Overall Height: 16-1/2"
- Overall Width: 15-19/32"
- Colour: Black
- Capacity: 15 Gal
- Wheel Diameter: 7"

Model No. TYP062
Mfg. No. DWST33090
Price/Each \$92.90



TOOL BOX ON WHEELS

- Structural foam body with an all-round water seal for water and dust resistance (IP54)
- Telescopic metal handle and heavy duty wheels allow for ergonomic mobility
- V-groove on the top of the lid holds in place materials like lumber and pipe for easy cutting
- Overall Depth: 28-1/2"
- Overall Height: 12"
- Overall Width: 12-1/2"
- Colour: Black
- Load Capacity: 80 lbs.

Model No. TYP065
Mfg. No. DWST28100
Price/Each \$99.50



2-WHEEL SERVICE TOOL KIT

- 3-5/8" Roller bearing wheels ensure maximum stability and easy transport over rough pavement or stairs
- Made from super tough, black polyethylene rotationally molded for maximum strength
- Extra wide, comfortable extension handle is molded into case to prevent wear
- Extension handle features easy one-handed release and locks in place automatically when extended and retracted
- Two convenient tote handles are spring loaded for protection
- Features "D" ring bungee cords to carry other cases on top
- Contains 3-panel hinged tool pallet in lid and additional pallet in bottom
- Holds more than 50 individual hand tools and over 40 screwdriver/nutdriver blades and handles
- Extra large space allows for storage of additional equipment
- Colour: Black
- Overall Depth: 13-1/2"
- Overall Width: 16-3/4"
- Overall Height: 20"

Model No. TTB863
Mfg. No. TCMB100MTW
Price/Each \$1021.40



Xcelite®

GEN 2 MOBILE TOOL CHEST

- Features four shallow drawers on top and two deep drawers on the bottom
- Features an extended length trolley handle, removable drawers, and aluminum rail slide system and heavy-duty buttress hinges
- Stable, wide track mobility and field replaceable wheels increase efficiency
- Design has been tested for water submersion, extreme temperatures, and drop tested from 5 feet
- Colour: Black
- Overall Depth: 18"
- Overall Width: 24"
- Overall Height: 14-3/4"
- Top Tray Dimensions: 19.47"L x 9.6"W x 2.62"D
- Shallow Drawer Dimensions: 18.07"L x 10.86"W x 1.21"D
- Deep Drawer Dimensions: 1 8.01"L x 10.8"W x 2.75"D
- Weight: 48.4 lbs.



Model No.	Mfg. No.	No. of Drawers	Description	Price /Each
UA1280	004500-0420-110	6	With 6 Removable drawers (4 shallow and 2 deep)	1645.00
UA1281	004500-0610-110	7	With 7 Removable drawers (6 shallow and 1 deep)	1645.00

PLASTIC TOOL BOXES

- ABS plastic latches
- Heavy-duty polypropylene fabrication
- Removable inner trays
- Deep storage compartments
- Padlock eye for safe storage

AURORA
TOOLS

Model No.	Dimensions				Features	Price /Each
	W"	x	D"	x H"		
TLV082	15	x	7	x 5 1/2	1 Removable Inner Tray	31.95
TLV083	17 1/2	x	9 1/2	x 8	1 Removable Inner Tray	53.95
TLV084	17 1/2	x	9 1/2	x 8	1 Removable Inner Tray, 2 Parts Boxes, 1 Organizer	64.95
TLV085	22	x	11	x 10 1/2	1 Removable Inner Tray, 3 Organizers	85.95
TLV086	22	x	11	x 14 1/2	1 Removable Inner Tray, 3 Organizers, 2 Drawers	139.00
TLZ117	5 1/2	x	5 1/2	x 1 1/2	Parts Box	6.25
CF333	10-3/4	x	5-3/8	x 1-1/2	Compartment Case	8.95



TLV082



TLV083



TLV084



TLV085



TLV086

FATMAX® STRUCTURAL FOAM TOOL BOX

- Extra heavy-duty, professional tool box
- Water seal makes tool box water resistant
- Ideal for carrying power tools, hand tools and medium-size to large items
- Portable half tray allows room for storage of larger items
- V-groove with ruler on top of lid holds materials such as lumber and pipes in place for cutting
- Colour: Black, Yellow



STANLEY

Model No.	Mfg. No.	Overall Depth"	Overall Height"	Overall Width"	Price /Each
TER080	023001W	12	10-1/2	23	58.40
TER082	028001L	12-1/2	11	28	82.90

ONE-TOUCH TOOL BOX WITH REMOVABLE LID ORGANIZERS

- One-hand operation latch enables opening while other hand is occupied
- Robust structural design and large volume
- Removable lid top organizers for convenient small parts storage organization on the go
- Removable tray allows enough space for large tools to be stored underneath
- Extra-wide soft grip handle for easy lifting
- Colour: Black



STANLEY

Model No.	Mfg. No.	Overall Depth"	Overall Height"	Overall Width"	Price /Each
TER085	STST16420	8-2/5	6-1/2	16	25.20
TER087	STST19420	10-1/2	9-1/5	19	37.90

2000 SERIES TOOL BOX WITH TRAY

- Two lid organizers for small parts storage that is accessible without opening the tool box
- Built-in padlock eye for small locks to keep contents secure
- Soft, wide rubber coated handle allows for easy & comfortable grip
- Nickel metal-plated latches
- Tote tray inside to store smaller items
- Colour: Black, Yellow



STANLEY

Model No.	Mfg. No.	Overall Depth"	Overall Height"	Overall Width"	Price /Each
TER077	016013R	7-1/10	8-1/10	16	18.50
TER078	019151M	10-1/5	9-4/5	19-1/5	28.50
TER081	024013S	11-1/4	11	24	44.50

TOTE WITH POWER TOOL CASE

- Top case for power tools and small parts with an integrated handle
- Long metal carry handle for easy grip when carrying
- Front push-button for easy detaching/attaching of the case to the tote unit
- Colour: Black
- Overall Length: 26-3/8"



DEWALT

Model No.	Mfg. No.	Overall Depth"	Overall Height"	Overall Width"	Price /Each
TYP063	DWST24070	24	11-3/16	12-13/16	64.90

TOOL STORAGE

METAL TOOL BOXES

- High-gloss, scratch and corrosion resistant powder coat paint finish
- Chrome-plated handles and latches for a premium look and superior protection against corrosion



Model No.	Mfg. No.	Description	Overall Depth"	Overall Height"	Overall Width"	Colour	Storage Capacity	Price /Each
TEQ510	9101	Tool Box	20	5	6-1/4	Blue	328 cu. in.	40.50
QD367	9107	Tool Box	7	16	7-1/2	Red	840 cubic in.	58.90
QD368	9109	Tool Box	7-1/8	19	7-1/2	Red	1004 cubic in.	60.50
TEQ515	9119	Tool Box	8-13/20	21-3/10	9	Red	1,319 cubic in.	83.90
TEQ511	9104	Tool Box	10-3/4	25-1/2	10	Red	1,866 cubic in.	115.00
TEQ522	97103A	Tool Box with 3 Drawers	9-3/5	21-3/10	14-1/2	Red	1,555 cubic in.	175.00
TEQ523	97103B	Tool Box with 3 Drawers	10	20-1/2	12	Black	1,734 cubic in.	259.00

PORTABLE TOOL BOXES WITH METAL TOOL TRAY

- Durable steel construction
- Heavy-plated latches
- Inner trays in regular hand boxes
- High gloss powder coat paint finish
- Colour: Red
- Unit Capacity: 50 lbs.

TEP516



Model No.	Overall Depth"	Overall Height"	Overall Width"	Weight lbs.	Price /Each
TEP516	6	6-1/2	16	10	61.95
TEP336	8-3/4	9	21	12	105.00

HEAVY-DUTY TOOL BOX

- Includes removable tote tray
- High-gloss, scratch and corrosion resistant powder coat paint finish
- Chrome-plated handles and latches for a premium look and superior protection against corrosion
- Colour: Red
- Storage Capacity: 1627 cubic in.

MLN523



Model No.	Mfg. No.	Overall Depth"	Overall Height"	Overall Width"	Weight lbs.	Price /Each
MLN523	9120	8-1/2	9-1/2	20	11	75.50

PORTABLE TOOL BOX

- Features ball bearing drawer sliders
- Keyed centre lock for improved security
- Powder coat finish wipes clean easily and resists rust and corrosion
- No. of Drawers: 3
- Colour: Black
- Material: Steel
- Drawer Height: 2"



Model No.	Mfg. No.	Overall Depth"	Overall Height"	Overall Width"	Price /Each
TPB061	83151	8-1/2	12	20	121.00

HAND TOOL BOX WITH DRAWERS

- 3 full-width drawers featuring ball bearing slides for smooth operation
- Powder-coated paint finish
- Lock and key included
- Drawer liners included
- Rubber coated lifting handles
- Colour: Black



Model No.	Mfg. No.	Overall Depth"	Overall Height"	Overall Width"	Price /Each
NJH970	D069001	10	12	20	169.00

INDUSTRIAL TOOL CARTS/CHESTS

- Double wall steel construction for added strength
- Full extension ball bearings slides on all drawers
- Extruded aluminum drawer handle trim
- Non-slip drawer liners
- Powder coat scratch resistant black paint
- Features 2 fixed HD casters & 2 swivel HD casters with toe locks



TER066



TER064



TER067

AURORA
TOOLS

Model No.	No. of Drawers	Overall Depth"	Overall Width"	Overall Height"	Drawer Capacity lbs.	Unit Capacity lbs.	Caster Dimensions	Price /Each
TOOL CARTS								
TER064	5	18-3/4	27	31-1/2	100	1400	5" x 2" (127 mm x 51 mm)	575.00
TER065	7	18-3/4	27	39	100	1400	5" x 2" (127 mm x 51 mm)	690.00
TER067	11	18-3/4	41	39-1/3	100	1400	5" x 2" (127 mm x 51 mm)	1135.00
TOOL CHESTS								
TER066	4	12	26	14-1/2	100	1000	-	385.00
TER068	10	17-3/4	41	19	100	1000	-	765.00

HEAVY-DUTY TOOL CART

- Heavy-duty double wall steel construction for added strength
- Quadra level ball bearing slides on all drawers
- Drawers feature soft close technology
- Heavy-duty reinforced bottom support rails for heavier loads
- Full extension slides for easy reach inside
- Integrated latch security drawer system prevents drawers from accidentally opening
- Powder coat scratch resistant black paint
- Non-slip drawer liners and a thick rubber top mat that provides an excellent working surface
- Power and USB outlets on the side of the cabinet makes it quick and easy to charge your power tools and mobile devices
- Heavy-duty casters with double layer ball bearings



AURORA
TOOLS

Model No.	No. of Drawers	Overall Depth"	Overall Width"	Overall Height"	Drawer Capacity lbs.	Unit Capacity lbs.	Caster Dimensions	Price /Each
TER069	7	22	28	42-3/8	120	1400	5" x 2" (127 mm x 51 mm)	1180.00

UTILITY CARTS

- Heavy-duty steel construction
- Full extension ball bearings slides on all drawers
- High quality 4" swivel casters
- High-gloss powder coat scratch-resistant black paint
- One year limited warranty covers workmanship and manufacturing defects under normal usage



AURORA
TOOLS

Model No.	No. of Drawers	Overall Depth"	Overall Width"	Overall Height"	Drawer Capacity lbs.	Unit Capacity lbs.	Price /Each
TEP483	4	18	33	39	100	550	579.00

INDUSTRIAL TOOL CART

- Double-walled steel construction for added strength
- Full extension ball bearings slides on all drawers
- Double drawer glides on the top drawer
- Extruded aluminum drawer handle trim
- Keyed locking system for added security
- Round side chromed handle
- Non-slip drawer liners
- Tick top mat provides an excellent work surface
- High-gloss powder coat scratch-resistant paint
- Includes: 2 fixed HD casters & 4 swivel HD casters with toe locks - 5" (127mm) x 2" (51mm)
- Colour: Red



AURORA
TOOLS

Model No.	No. of Drawers	Overall Depth"	Overall Width"	Overall Height"	Drawer Capacity lbs.	Unit Capacity lbs.	Price /Each
TER103	12	24-1/2	56	38-1/8	100	1200	2185.00

TOOL STORAGE

INDUSTRIAL TOOL CARTS

- Double wall steel construction for added strength
- Full extension ball bearing slides on all drawers
- Extruded aluminum drawer handle trim
- Non-slip drawer liners
- Powder coat scratch-resistant black paint
- Features 2 fixed HD casters & 2 swivel HD casters with toe locks
- Colour: Black

TER216



TER218

AURORA
TOOLS

Model No.	No. of Drawers	Overall Depth"	Overall Width"	Overall Height"	Drawer Capacity lbs.	Unit Capacity lbs.	Price /Each
TER216	3	21-1/2	29-4/5	38-4/5	100	779	530.00
TER217	6	20-4/5	39	25-4/5	100	1140	870.00
TER218	8	21-1/10	44-3/10	36-7/10	100	1356	1120.00

HD SERIES ROLLER CABINET

- Made with a 19-gauge double wall steel construction to withstand the heaviest loads
- Tough and durable oven-baked wrinkle finish is resistant to corrosive fluids and easy to maintain
- Riveted aluminum mouldings protect box corners from impact while providing rigidity and strength
- Soft-close ball-bearing slides provide smooth and quiet operation even under heavy load
- Generous drawer depth provides increased storage capacity
- Heavy-duty casters with pedal lock provide easy transport
- Colour: Black
- Power Outlets: (6) AC Outlets, (2) USB Ports
- Colour: Black



JET

Model No.	Mfg. No.	No. of Drawers	Overall Depth"	Overall Width"	Overall Height"	Storage Capacity	Price /Each
AUW132	842605	7	21-27/50	27-4/5	40-31/100	12 370 cm ³	1368.00

PRO SERIES ROLLER CABINET

- Double wall steel construction with reinforced bottom channels on both cabinets and chests
- 100 lbs. capacity ball bearing slides on all drawers
- Select drawers with 2 sets of slides to accommodate heavier loads
- Centre slide on full width drawer supports heavier loads
- Power supply management includes 4 AC and 2 USB outlets on roller cabinets
- Extruded aluminum drawer pulls ensure positive grip when opening heavily loaded drawers
- Riveted aluminum mouldings protect box corners from impact
- Heavy-duty casters with pedal brake
- Roller cabinets include wood tops from a renewable resource
- Gas struts on top chests
- Colour: Red
- Wheel Rating: 600 lbs.
- Wheel Type: (4) Swivel, (2) Fixed



JET

Model No.	Mfg. No.	No. of Drawers	Overall Depth"	Overall Width"	Overall Height"	Drawer Capacity lbs.	Unit Capacity lbs.	Storage Capacity	Price /Each
AUW130	842524	10	24-1/10	55-9/10	39-7/10	200	1800	23 872.8 cm ³	2599.00

TOOL CHESTS

- Integrated power and USB ports on chest to charge power tools, batteries, and electronics
- POSI-LATCH® drawer latching system for easy release by lifting the drawer trim
- Under-lid area includes an open front, gas struts, and top mat
- Heavy-duty keyed locking system safeguards your tools
- Double wall steel construction is reinforced with internal corner gussets
- Lid stiffener provides extra stability



DEWALT

Model No.	Mfg. No.	No. of Drawers	Drawer Load Capacity lbs.	Cubic inches of storage	Overall Depth"	Overall Width"	Overall Height"	Colour	Price /Each
TER061	DWST25181	8	100	15746	18	51-1/2	24-1/2	Black	1199.00

PRO+ SERIES INTERMEDIATE CHESTS

- Heavy-duty 100 lbs. bearing slides standard on all drawers
- Completely redesigned locking system with tubular key
- Automotive style powder coat paint finish for superior scratch and chemical resistance



Model No.	Mfg. No.	No. of Drawers	Colour	Overall Depth"	Overall Width"	Overall Height"	Price /Each
NJH109	93503	3	Red	19	26	13-1/3	485.00
NJH103	93120	12	Red	19	26	21	905.00
NJH102	93119	9	Red	19	42	23-1/2	1345.00
NJH101	93109	9	Red	19	26	21	789.00
NJH100	93106	6	Red	16	26	16-1/3	619.00

NJH103



PRO+ SERIES ROLLER CABINETS

- Heavy-duty 100 lbs. bearing slides standard on all drawers
- Completely redesigned locking system with tubular key
- Redesigned side handle makes moving roller cabinets easy and comfortable
- Automotive-style powder coat paint finish for superior scratch and chemical resistance



Model No.	Mfg. No.	No. of Drawers	Colour	Overall Depth"	Overall Width"	Overall Height"	Price /Each
TER028	93212	12	Red	19	42	43-1/2	1845.00
NKE061	93204	4	Red	19	26	36	955.00
NJH107	93270	7	Red	19	26	42	1095.00
NJH106	93250	5	Red	19	26	36	945.00
NJH105	93215	15	Red	19	42	43-1/2	1915.00
NJH104	93211	11	Red	19	26	42	1235.00

TER028



ROLLER CABINETS

- Safety latch system prevents drawers from accidentally opening
- Heavy-duty roller bearing slides allow heavily loaded drawers to open and close with ease
- Heavy gauge steel construction for greater load ratings & storage capacities
- Premium quality casters with greater load ratings allow easier movement on all surfaces
- Oval handles on roller cabinets allow comfortable gripping and maneuvering
- Automotive style power coat paint in hammer-tone texture provides superior scratch and corrosion resistance
- Robust tubular locking mechanism provides reliable and secure theft protection
- Drawer liners included



Model No.	Mfg. No.	No. of Drawers	Colour	Overall Depth"	Overall Width"	Overall Height"	Storage capacity	Price /Each
TEQ530	99206SB	6	Black	19-1/2	34	39-1/8	13,357 cubic in.	1765.00
TEQ535	99507SB	7	Black	18	26-1/2	39-13/100	9,147 cubic in.	1069.00
TEQ531	99208SB	8	Black	19-1/2	34	39-13/100	13,294 cubic in.	1909.00
TEQ536	99509SB	9	Black	18	26-1/2	40	9,157 cubic in.	1175.00
TEQ532	99209SB	9	Black	24	53	39-3/4	25,900 cubic in.	4005.00
TEQ533	99210SB	10	Black	19	42	40	13,901 cubic in.	2525.00
TEQ534	99213SB	13	Black	19	42	40	13,677 cubic in.	2579.00
TEQ529	99113SB	13	Black	34	53	39-3/4	25,500 cubic in.	4655.00

TEQ530



TOP CHEST

- Safety latch system prevents drawers from accidentally opening
- Heavy-duty roller bearing slides allow heavily loaded drawers to open and close with ease
- Heavy gauge steel construction for greater load ratings & storage capacities
- Heavy-duty lifting handles with 90° stop for easy lifting of top chests
- Gas shocks assist in opening and closing lids on top chests (41-1/2" & 53-3/8" models only)
- Automotive style power coat paint in hammer-tone texture provides superior scratch and corrosion resistance
- Drawer liners included
- Robust tubular locking mechanism provides reliable and secure theft protection



Model No.	Mfg. No.	No. of Drawers	Colour	Overall Depth"	Overall Width"	Overall Height"	Storage capacity	Weight lbs.	Price /Each
TEQ545	99808SB	8	Black	16	26	19-1/4	5,453 cubic in.	86	795.00
TEQ544	99806SB	6	Black	16	26	19	5,474 cubic in.	86	685.00
TEQ543	99508SB	8	Black	24	53-3/8	19-3/4	17,000 cubic in.	265	2789.00
TEQ542	99108SB	8	Black	18-1/2	41-1/2	20-1/2	9,744 cubic in.	139	1559.00
TEQ541	99107SB	7	Black	18-1/2	41-1/2	23-1/2	10,950 cubic in.	183	1765.00
TEQ540	99105SB	5	Black	19-1/8	33-1/2	19-1/4	9,034 cubic in.	127	1179.00

TEQ544



TOOL STORAGE

POWERED TOOL CART

- Features charging station with 6 outlets and 4 USB ports
- Features pegboard surface and shelf on the front of the cart for quick access
- Includes EVA top mat and EVA drawer liners to protect tools and cart
- Includes customizable partitions on the top drawer
- Features lockable side compartment
- Feature ball bearing slides
- Colour: Black, Orange
- Storage Capacity: 19000 Cubic Inch
- Total Load Capacity: 2000 lbs.
- Material: 20 gauge steel
- Caster Style: 2 rigid and 2 locking swivel casters
- Caster Size: 6" x 2" polyurethane casters
- Caster Capacity: 800 lbs.

GW GEARWRENCH



Model No.	Mfg. No.	No. of Drawers	Overall Depth"	Overall Width"	Overall Height"	Price /Each
TEQ808	83169	11	24-7/16	42-1/2	41	2354.00

SHD SERIES JOBSITE TOOLBOX

- 16-gauge steel body and lid provides industrial style strength
- High-security design includes staked and welded piano hinge and dual recessed lock housings
- Overlapping lid prevents leaks and features full width reinforcing bolster for added strength
- Features cord pass-through with rubber grommets for secure overnight charging of tools
- Heavy-duty gas spring provides easy opening and prevents accidental lid slamming
- High-visibility orange powder coat paint provides superior scratch and corrosion resistance
- Skids are predrilled to accept optional 6"x2" industrial grade casters
- 12-gauge 4-way skids allow near 360° access for quick and easy transport
- Overall Depth: 24-1/5"
- Overall Height: 28-3/5"
- Overall Width: 60"
- Colour: Orange
- Material: Steel
- Capacity: 16 Cubic Feet
- Bottom Channel Steel Gauge: 12
- Lid Steel Gauge: 16
- Wall Steel Gauge: 16

Model No. AUW129
Mfg. No. 842482
Price/Each \$1368.00



SUPER HEAVY-DUTY JOBSITE TOOL STORAGE BOX

- 16-gauge steel body and lid provides industrial style strength
- High-security design includes staked and welded piano hinge and dual recessed lock housings
- Overlapping lid prevents leaks and features full width reinforcing bolster for added strength
- Features cord pass-through with rubber grommets for secure overnight charging of tools
- Heavy-duty gas spring provides easy opening and prevents accidental lid slamming
- High-visibility orange powder coat paint provides superior scratch and corrosion resistance
- Skids are predrilled to accept optional 6"x2" industrial grade casters
- 12-gauge 4-way skids allow near 360° access for quick and easy transport
- Overall Depth: 19"
- Overall Height: 17-1/2"
- Overall Width: 32-1/8"
- Colour: Orange
- Material: Steel
- Capacity: 4.5 Cubic Feet

Model No. AUW128
Mfg. No. 842480
Price/Each \$684.00



JOBSITE TOOL BOX

- 2-gas struts to assist with lid opening
- Piano hinge closes lid securely to keep the elements out
- Rubber grommet to allow electrical cord pass through
- Heavy-duty flip-up side handles
- Moveable by 12-Gauge forklift rails
- Recessed hasp to securely lock with padlock (not included)
- Finished with UV-resistant powder coat
- Colour: Blue
- Material: Steel

UAW869



UAW870



AURORA
TOOLS

Model No.	Overall Depth"	Overall Width"	Overall Height"	Cap. Cubic Feet	Load Cap. lbs.	Price /Each
UAW869	24	27-3/5	48	16	500	586.00
UAW870	24	27-1/2	60	20	1100	742.00



CANADA'S LEADING MATERIAL HANDLING SUPPLIER

JOBOX® OFFERS:



EZ-LOADER® SKID BOLSTERS

- Fork lift from any side
- Easily load or unload heavy, fully loaded boxes from any sides
- One piece 7-gauge steel skid bolster reinforces the bottom of the box
- With holes for optional caster

TEXTURED POWDER PAINT FINISH

- Improved durability over liquid paint
- 10 times more corrosion resistance
- 5 times more abrasion resistance
- 2 times more chip resistance
- 2 times more scratch resistance

SITE-VAULT™ SECURITY SYSTEM

- 3 locking point system
- Cover plates protect the 3-lock hooks from being bent, broken, cut or pulled out
- Full length, high strength 12-gauge lock console protects the system and reinforces the front of the lid or door
- Padlock is securely installed inside the fully welded 14-gauge steel housing
- Exclusive: fluorescent reflective orange tape indicates when the Jobox® is unlocked



SITE-VAULT™ PIANO BOX

- Heavy-duty beveled edge lid eliminates hip spikes on sharp corners and strengthens lid
- Patented security system has a full-length steel lock console with 3 locking points and reflective orange lock indicator that shows when the box is locked/unlocked
- Heavy-duty 4-way skid bolsters allow fork lift loading from any side for quicker and easier transport
- Built-in door storage provides easy access for hanging harnesses, jackets, hardhats, etc.
- Integrated sidewall locker provides a padlock-able area for personal items
- Heavy-duty top shelf supports up to 1,000 lbs. and provides excellent organization
- Low height front panel for easier loading and unloading of equipment
- Lift-N-Stow™ shelf supports up to 500 lbs. and lifts for easy loading
- Compatible with Master #1, #5, #175, and American 50 padlocks
- Lid bolsters resist bending from cargo placed on top of the box and from attempted break-ins
- Colour: Orange
- Material: Steel



UAI901



Model No.	Mfg. No.	Overall Depth"	Overall Height"	Overall Width"	Capacity Cu. Ft.	Price /Each
UAI901	2-681990-01	31	51	48	43.9	2371.00
UAI902	2-682990-01	31	51	60	54.9	2371.00
UAI905	2-685990-01	31	64	74	85	3870.00
UAI906	2-688990-01	31	39	60	42	2259.00
UAI907	2-689990-01	31	51	74	67.7	2936.00

SITE-VAULT™ DROP FRONT PIANO BOX

- Heavy-duty beveled edge lid eliminates hip spikes on sharp corners and strengthens lid
- Patented security system has a full-length steel lock console with 3 locking points and reflective orange lock indicator that shows when the box is locked/unlocked
- Heavy-duty 4-way skid bolsters allow fork lift loading from any side for quicker and easier transport
- Built-in door storage provides easy access for hanging harnesses, jackets, hardhats, etc.
- Integrated sidewall locker provides a padlock-able area for personal items
- Heavy-duty top shelf supports up to 1,000 lbs. and provides excellent organization
- Low height front panel for easier loading and unloading of equipment
- Lift-N-Stow™ shelf supports up to 500 lbs. and lifts for easy loading
- Compatible with Master #1, #5, #175, and American 50 padlocks
- Lid bolsters resist bending from cargo placed on top of the box and from attempted break-ins
- Colour: Orange
- Material: Steel



UAI903



Model No.	Mfg. No.	Overall Depth"	Overall Height"	Overall Width"	Capacity Cu. Ft.	Price /Each
UAI903	2-683990-01	31	51	60	54.9	3279.00
UAI904	2-684990-01	31	51	74	67.7	4005.00

HIGH CAPACITY DROP-FRONT CHESTS

- Site-Vault™ security system with 12-gauge steel lock console with two locking points, full length console and fully welded padlock housing make the lid virtually impossible to bend or pry
- Ez-Loader® skid bolster made of 7-gauge one piece steel allows fork lift access from all sides to allow easier loading and unloading
- Grip-rite™ lifting channel
- Power cord access on the top side of the chest
- 37% more capacity for storing taller, bulkier equipment
- Extra wide (44" W), low-incline ramp supports up to 1000 lbs. for safe and easy loading and unloading and is pad-lockable
- 7-gauge, one-piece steel bolsters resist damage when dropped



Model No.	Dimensions				Usable Cu. Ft.	Wt. lbs.	Price /Each
	W"	x	D"	x			
TEP341	60	x	31	x	45	41.5	3028.00

TOOL STORAGE

WELDER'S BOXES & SMALL CHESTS

- Compact and portable for flexible, secure storage
- A heavily-reinforced 16-gauge steel construction
- Staked and welded steel hinges
- **TEP348** is a welder's box that offers a notched upper side for storing tools connected to supply hoses



TEP349



TEP348



Model No.	Description	Dimensions			Usable Cu. Ft.	Wt. lbs.	Price /Each
		W"	D"	H"			
TEP349	Small chest w/hasp lock	30	16	12	3.3	33	440.00
TEP348	Welder's box	30	16	12	3.3	33	383.00

SITE-VAULT™ CHESTS

- Heavy-duty beveled edge lid eliminates hip spikes on sharp corners and strengthens lid
- Patented security system has a full-length steel lock console with 3 locking points and reflective orange lock indicator that shows when the box is locked/unlocked
- Heavy-duty 4-way skid bolsters allow fork lift loading from any side for quicker and easier transport
- Dual built-in lid storage bins
- EZ-Lock support arm secures and locks lid in open position for safe use
- Integrated side wall cargo bin provides quick access for small tools and parts
- Ergonomic, recessed handles provides clearance to eliminate finger pinching
- Compatible with Master #1, #5, #175, and American 50 padlocks
- Staked and welded hinges
- Colour: Orange
- Material: Steel



UAI894



Model No.	Mfg. No.	Overall Depth"	Overall Height"	Overall Width"	Capacity Cu. Ft.	Price /Each
UAI895	2-652990	20	27-1/2	36	11.5	918.00
UAI896	2-653990	20	27-1/2	42	13.4	1025.00
UAI897	2-654990	24	30-3/4	48	20.5	1258.00
UAI898	2-655990	24	30-3/4	60	25.6	1523.00
UAI899	2-656990	30	36-3/4	48	30.6	1530.00
UAI900	2-658990	24	30-3/4	72	30.75	1729.00

TRADESMAN SERIES JOBSITE CHEST

- Grip-Rite™ lifting channel provides better grip on lid for easier and safer lid operation
- Features enclosed dual lock system that resists saws, pry bars, and bolt cutters
- Lock system rain drain protects locks and box contents from moisture
- EZ-Lock support arm secures and locks lid in open position for safe use
- Ergonomic, recessed handles provides clearance to eliminate finger pinching
- 4-way EZ-loader skid bolsters allow fork lift loading from any side for quicker and easier transport
- Colour: Orange
- Material: Steel



UAI908



Model No.	Mfg. No.	Overall Depth"	Overall Height"	Overall Width"	Capacity Cu. Ft.	Price /Each
UAI908	CJB635990	19-1/2	22	36	8.9	706.00
UAI909	CJB636990	20	22	42	10.7	804.00
UAI910	CJB637990	24	22	48	14.7	858.00
UAI911	CJB638990	24	22	60	18.3	1085.00

SLOPE LID CHESTS

All the characteristics of a regular Jobox® chest plus:

- Propped lid allows for a flat working surface
- Full length reinforced channel
- Lift-N-Stow™ hinged shelf to store bulky items in the bottom



Model No.	Dimensions W" x D" x H"	Usable Cu. Ft.	Wt. lbs.	Price /Each
TEP159	60 x 30 x 39 1/2	32.7	243	2211.00

CASTERS

- Heavy-duty casters for added mobility
- Set includes: 2 fixed and 2 swivels
- Hardware included

6"
Model No. TEP231
Price/Each \$158.00



JOBSITE STORAGE BOX

- Recessed handles prevent damage when moving the product
- Recessed padlock enclosure (padlock not included)
- Wire gripping grommet included for feeding wire or electrical cable for chargers
- UV protection
- All-welded and fully assembled
- Colour: Grey
- Material: Steel
- Capacity: 5 Cubic Feet
- Gauge: 14



UAI848



UAI844



UAI849

DURHAM MFG[®]
Est. 1922

Model No.	Mfg. No.	Overall Depth"	Overall Height"	Overall Width"	Capacity Cu. Ft.	Price /Each
UAI844	JSC-193218-94T-D719	19	17-13/16	32	5	1119.00
UAI845	JSC-244828-94T-D720	24	27-13/16	48	16	1529.00
UAI846	JSC-246023-94T-D720	24	22-3/4	60	20	1629.00
UAI848	JSCPB-316050-94T-D720	34-3/4	49-3/8	60	20	3725.00
UAI849	JSCSL-306040-94T-D720	30	39-3/8	60	20	2365.00



CABINETS

**CRESCENT
JOBBOX[®]**

- Site-Vault™ security system
- Heavy-duty doors with Grip-Rite™ channel
- Hand or foot operated latch released system
- 3/8 continuous hinges with hardened 1/4" steel pin and extra-large 1" knuckles
- Heavy-duty high strength shelves
- Three 5/8" steel locking pins per door
- Five models to choose from:

TEP168: 2 doors, 24" deep

TEP169: 4 doors features front and back access

TEP170: 2 doors, tall closet on right side

TEP171: 2 doors, 30" deep

TEP172: 2 doors, bin and clam shell, has heavy-duty galvanized movable dividers



TEP168



TEP169



TEP170



TEP172

Model No.	Dimensions				Usable Cu. Ft.	Wt. lbs.	Price /Each
	W"	x	D"	x H"			
TEP168	60 1/8	x	24 1/4	x 60 3/4	47.5	379	3257.00
TEP169	60 1/8	x	32 1/4	x 60 3/4	63.7	523	4950.00
TEP170	60 1/8	x	24 1/4	x 60 3/4	47.5	366	3560.00
TEP171	60 1/8	x	30 1/4	x 60 3/4	58.7	436	3844.00
TEP172	72	x	24	x 60 5/8	49	522	3908.00

TOOL STORAGE

ROLLING WORK BENCHES

- High capacity, fully adjustable interior; drawers and shelves are easy to move to match your requirements, additional drawers and shelves can be added in
- 18-gauge steel drawers with heavy-duty ball bearing glides

Includes: Two fixed and two lockable swivelling casters



ADDITIONAL DRAWERS & SHELVES:

Model No.	Description	Dimensions			Usable Cu. Ft.	Wt. lbs.	Price /Each
		W"	x D"	x H"			
TEP180	Basic Unit with 6" Casters	49 7/8	x 26 7/8	x 40 5/8	24.6	264	2819.00
TEP176	2 Drawers, 2 Shelves, 4" Casters	43 7/8	x 26 7/8	x 38 1/2	21.7	266.5	2977.00
TEP177	2 Drawers, 2 Shelves, 6" Casters	43 7/8	x 26 7/8	x 40 1/2	21.7	279.5	3194.00
TEP178	4 Drawers, 1 Shelf, 4" Casters	43 7/8	x 26 7/8	x 38 1/2	21.7	294	3513.00
TEP179	4 Drawers, 1 Shelf, 6" Casters	43 7/8	x 26 7/8	x 40 1/2	21.7	307	3650.00
TEP181	6 Drawers, 1 Shelf, 6" Casters	49 7/8	x 26 7/8	x 40 5/8	24.6	342	4782.00

For TEP176, TEP177, TEP178 and TEP179	For TEP180 and TEP181	Description
-	TEP183	Shelf
TEP184	TEP185	2 1/2" Drawer
TEP186	TEP187	4 1/2" Drawer
TEP188	TEP189	5 1/2" Drawer
TEP190	TEP191	10 1/2" Drawer

DRAWER CABINETS

- Site-Vault™ security system
- Ez-Loader® anti-tip skid bolsters: Front of bolster is extended to prevent tipping when drawers are open
- Heavy-duty doors with Grip-Rite™ channel
- Hand or foot operated latch released system
- 4 1/2" deep top shelf and 3" x 3" deep shelves on each door
- 3/8 continuous hinges with hardened 1/4" steel pin and extra-large 1" knuckles
- Three 5/8" steel locking pins per door
- High load capacity drawer: Three 2 1/2" deep drawers have 75-lb. capacity, five 5 1/2" deep drawers have 125-lb. load rating



Anti-Tip Skid Bolster

Model No.	Dimensions			Usable Cu. Ft.	Wt. lbs.	Price /Each
	W"	x D"	x H"			
TEP173	60 1/8	x 30 1/4	x 53 1/4	58.7	610	6083.00

FIELD OFFICES

- Site-Vault™ security system
- Ez-Loader® skid bolsters
- Grip-Rite™ recessed lifting channel
- One handle lock operation, slides down to release bottom doors, slides up for top door
- 30 cu. ft. storage locker, stores items up to 60" length and is opened by a lanyard inside the lower cabinet
- Full length heavy-duty stainless steel hinges resists corrosion and rust
- Built-in bottom door storage shelves
- Overhead tube storage, steel pegboard, storage area for plans and binders, lockable large desktop area and door safety pin latch



Model No.	Dimensions			Usable Cu. Ft.	Wt. lbs.	Price /Each
	W"	x D"	x H"			
TEP167	63	x 42	x 80	100	660	6075.00

FUEL TRANSFER TANKS

- Made for transporting diesel fuel (non-flammable liquids only)
- Internal baffles control the flow of content while moving
- Secure the tank to the truck bed with heavy-duty brackets
- Prevent pressure build-up with lockable filler cap and coupler
- Features 2" NPT reinforced bungs on either side that allow room for a pump on either side that allow room for a pump



TEQ721



TEQ716

STEEL

- Made of 14 ga. steel material for long-term durability
- Built-in rings allow for easy lifting and moving of empty tank
- Drain plug allows for liquids to be safely drained

ALUMINUM

- Aluminum Thread Plate: Heavy-duty 0.125" Thread Plate
- Finish: Clearcoat



TEQ719



TEQ728



STEEL

Model No.	Mfg. No.	Style	Dimensions W" x D" x H"	Colour	Capacity Gal.	Price /Each
TEQ719	486000	Column	9 x 54 x 19	White	36	1092.00
TEQ718	485000	Cube	23-1/4 x 23-1/4 x 24	White	50	909.00
TEQ713	480000	L-Shape	31 x 54 x 26	White	100	1510.00
TEQ714	480002	L-Shape	31 x 54 x 26	Black	100	1510.00
TEQ715	482000	L-Shape	31 x 27 x 26	White	48	937.00
TEQ720	488000	L-Shape	31 x 46 x 26	White	85	1198.00
TEQ721	488002	L-Shape	31 x 46 x 26	Black	85	1198.00
TEQ722	498000	L-Shape	33 x 60-1/4 x 25	White	100	1496.00
TEQ723	498002	L-Shape	33 x 60-1/4 x 25	Black	100	1496.00
TEQ716	484000	Rectangular	23-1/4 x 45-5/8 x 24	White	100	1306.00
TEQ717	484002	Rectangular	23-1/4 x 45-5/8 x 24	Black	100	1306.00

ALUMINUM

Model No.	Mfg. No.	Style	Dimensions W" x D" x H"	Colour	Capacity Gal.	Price /Each
TEQ726	437000	L-Shape	31 x 57-1/2 x 25	Silver	100	1986.00
TEQ727	438000	Rectangular	23-1/4 x 45-1/4 x 23-1/4	Silver	100	1638.00
TEQ728	439000	Cube	23-1/4 x 23-1/4 x 23-1/4	Silver	50	1217.00

ALUMINUM FUEL TRANSFER TANK & CHEST

- Made for transporting diesel fuel (non-flammable liquids only)
- Offers the convenience of a transfer tank and a removable chest
- 2 center baffles control the flow of content while moving
- Secure the tank to the truck bed with 4 heavy-duty brackets
- Stainless steel paddle handles are leak-proof and weather-resistant
- High-strength body resists break-ins
- Prevent pressure build-up with lockable filler cap and coupler
- Features 2" NPT reinforced bungs on either side that allow room for a pump
- Aluminum Thread Plate: Heavy-duty 0.125" Thread Plate
- Finish: Clearcoat
- Chest Storage Space: 4.5 Cubic Feet



Model No.	Mfg. No.	Style	Dimensions W" x D" x H"	Colour	Capacity Gal.	Price /Each
TEQ724	433000	Rectangular	31 x 48-1/4 x 19	Silver	74	2620.00